

## **Appendix B3**

### Turning Movement Counts



Project : VBH Malta NY  
 Site : Site 4  
 Location : 42.948550, -73.790036  
 Survey Date : 2021-04-28, Wednesday

### Turning Movement Data Plot

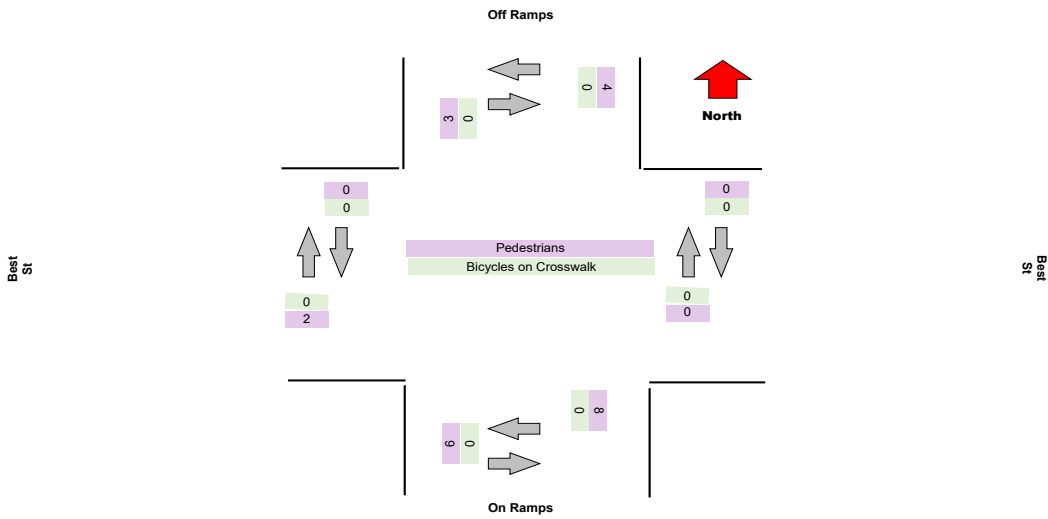
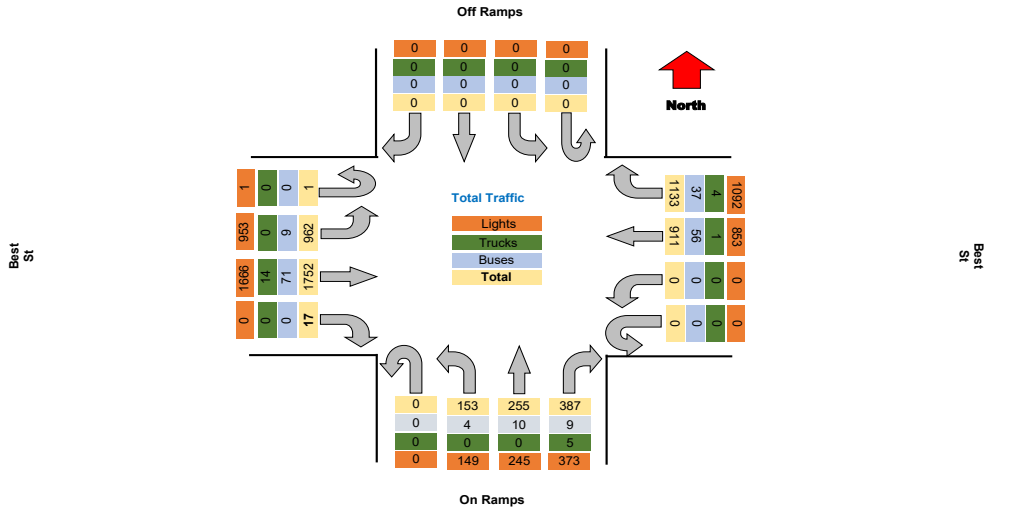

Project : VBH Malta NY  
Site : Site 4  
Location : 42.948550, -73.790036

TSTData.com

Survey Date : 2021-04-28, Wednesday

### Turning Movement Peak Hour Data (AM)

7:30:00 AM

Leg Direction	Off Ramps								Best St								On Ramps								Best St								Total
	Southbound				Westbound				Northbound				Eastbound				Northbound				Eastbound												
Start Time	Right	Thru	Left	U-Turn	App Total	Peds CW	Peds CCW		Right	Thru	Left	U-Turn	App Total	Peds CW	Peds CCW		Right	Thru	Left	U-Turn	App Total	Peds CW	Peds CCW		Right	Thru	Left	U-Turn	App Total	Peds CW	Peds CCW		
7:30:00 AM	0	0	0	0	0	0	0		55	56	0	0	111	0	0		17	17	10	0	44	0	0		0	74	70	0	144	0	0		299
7:45:00 AM	0	0	0	0	0	1	3		82	84	0	0	169	0	0		28	19	15	0	62	0	0		0	115	71	0	186	0	0		417
8:00:00 AM	0	0	0	0	0	0	0		66	72	0	0	138	0	0		34	16	15	0	65	1	1		0	125	78	0	203	0	0		406
8:15:00 AM	0	0	0	0	0	0	0		68	74	0	0	142	0	0		16	12	16	0	44	0	0		0	102	67	0	169	0	0		355
<b>Grand Total</b>	0	0	0	0	0	1	3		271	286	0	0	559	0	0		95	64	56	0	215	1	1		0	416	285	0	702	0	0		1477
% Approach	#DIV/0!	#DIV/0!	#DIV/0!	#DIV/0!	0.0%	0.0%	0.0%		14.2%	85.8%	0.0%	0.0%	0.0%	0.0%	0.0%		45.1%	41.7%	13.2%	0.0%	0.0%	0.0%	0.0%		0.0%	66.2%	33.8%	0.0%	0.0%	0.0%	0.0%		
% Total	0.0%	0.0%	0.0%	0.0%	0.0%	0.0%	0.0%		18.3%	19.4%	0.0%	0.0%	37.9%	0.0%	0.0%		6.4%	4.3%	3.8%	0.0%	14.6%	0.0%	0.0%		0.0%	28.2%	19.4%	0.0%	47.5%	0.0%	0.0%		
PHF	0.000	0.000	0.000	0.000	0.000	0.000	0.000		0.826	0.851	0.000	0.000	0.828	0.000	0.000		0.699	0.842	0.875	0.000	0.827	0.000	0.000		0.000	0.832	0.917	0.000	0.865	0.000	0.000		0.885
Lights	0	0	0	0	0	0	0		266	266	0	0	532	0	0		90	58	53	0	201	0	0		0	403	282	0	685	0	0		1418
% Lights	0.0%	0.0%	0.0%	0.0%	0.0%	0.0%	0.0%		88.2%	93.0%	0.0%	0.0%	95.0%	0.0%	0.0%		84.7%	90.6%	94.6%	0.0%	93.5%	0.0%	0.0%		0.0%	96.9%	98.6%	0.0%	97.6%	0.0%	0.0%		96.0%
Trucks	0	0	0	0	0	0	0		2	1	0	0	3	0	0		1	0	0	0	1	0	0		0	5	0	0	5	0	0		9
% Trucks	0.0%	0.0%	0.0%	0.0%	0.0%	0.0%	0.0%		0.7%	0.3%	0.0%	0.0%	0.5%	0.0%	0.0%		1.1%	0.0%	0.0%	0.0%	0.5%	0.0%	0.0%		0.0%	1.2%	0.0%	0.0%	0.7%	0.0%	0.0%		0.6%
Buses	0	0	0	0	0	0	0		3	18	0	0	21	0	0		4	6	3	0	13	0	0		0	8	4	0	12	0	0		46
% Buses	0.0%	0.0%	0.0%	0.0%	0.0%	0.0%	0.0%		1.1%	6.3%	0.0%	0.0%	0.0%	0.0%	0.0%		4.2%	9.4%	5.4%	0.0%	0.0%	0.0%	0.0%		0.0%	1.9%	1.4%	0.0%	0.0%	0.0%	0.0%		3.1%
Pedestrians	0	0	0	0	1	3	0		0	0	0	0	0	0	0		0	0	0	0	1	1	0		0	0	0	0	0	0	0		0
% Pedestrians	0.0%	0.0%	0.0%	0.0%	0.0%	100.0%	100.0%		0.0%	0.0%	0.0%	0.0%	0.0%	0.0%	0.0%		0.0%	0.0%	0.0%	0.0%	0.0%	100.0%	100.0%		0.0%	0.0%	0.0%	0.0%	0.0%	0.0%	0.0%		0.0%
Bicycles on Crosswalk	0	0	0	0	0	0	0		0	0	0	0	0	0	0		0	0	0	0	0	0	0	0	0	0	0	0	0	0	0		0
% Bicycles on Crosswalk	0.0%	0.0%	0.0%	0.0%	0.0%	0.0%	0.0%		0.0%	0.0%	0.0%	0.0%	0.0%	0.0%	0.0%		0.0%	0.0%	0.0%	0.0%	0.0%	0.0%	0.0%	0.0%	0.0%	0.0%	0.0%	0.0%	0.0%	0.0%	0.0%		0.0%

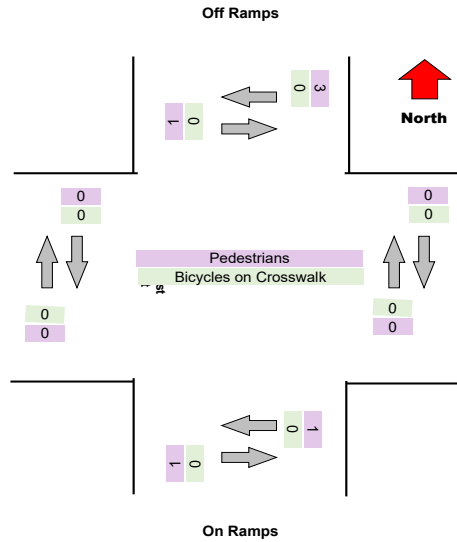
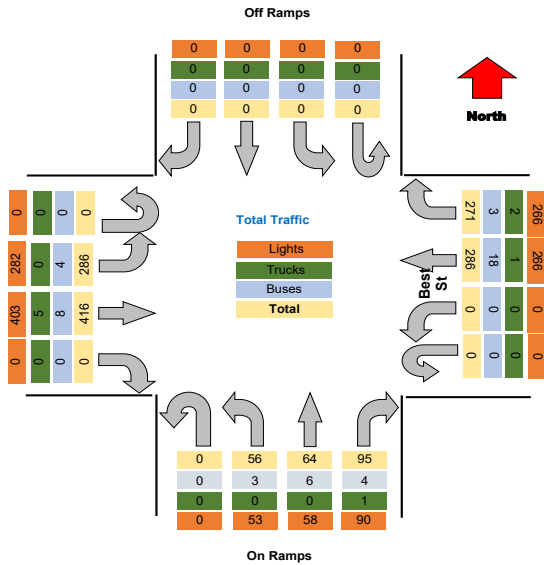

Project : VBH Malta NY  
Site : Site 4  
Location : 42.948550, -73.790036

TSTData.com

Survey Date : 2021-04-28, Wednesday

### Turning Movement Peak Hour Data (PM)

4:30:00 PM

Leg Direction	Off Ramps										Best St				On Ramps										Best St				Total	
	Southbound					Westbound					Northbound		Eastbound		Northbound					Eastbound										
	Right	Thru	Left	U-Turn	App Total	Right	Thru	Left	U-Turn	App Total	Right	Thru	Right	Thru	Left	U-Turn	App Total	Right	Thru	Left	U-Turn	App Total	Right	Thru	Left	U-Turn	App Total	Peds CW		Peds CCW
4:30:00 PM	0	0	0	0	0	92	54	0	0	146	0	0	37	19	11	0	67	1	0	0	0	1	0	155	77	0	232	1	0	445
4:45:00 PM	0	0	0	0	0	77	57	0	0	134	0	0	28	19	12	0	59	1	2	0	0	3	0	143	63	0	206	0	0	399
5:00:00 PM	0	0	0	0	0	76	58	0	0	134	0	0	37	19	7	0	63	1	0	0	0	1	0	129	93	0	222	0	0	419
5:15:00 PM	0	0	0	0	0	82	58	0	0	140	0	0	29	15	7	0	51	0	1	0	0	1	0	115	69	1	185	0	0	376
Grand Total	0	0	0	0	0	327	227	0	0	554	0	0	131	72	37	0	240	3	3	0	0	6	0	542	302	1	845	1	3	1639
% Approach	#DIV/0!	#DIV/0!	#DIV/0!	#DIV/0!	0.0%	14.2%	85.8%	0.0%	0.0%	0.0%	45.1%	41.7%	0.0%	0.0%	0.0%	0.0%	0.0%	0.0%	66.2%	33.8%	0.0%	0.0%	0.0%	33.1%	18.4%	0.1%	51.6%	0.0%	0.0%	0.0%
% Total	0.0%	0.0%	0.0%	0.0%	0.0%	20.0%	13.8%	0.0%	0.0%	33.8%	0.0%	0.0%	8.0%	4.4%	2.3%	0.0%	14.6%	0.0%	0.0%	0.0%	0.0%	0.0%	0.0%	33.1%	18.4%	0.1%	51.6%	0.0%	0.0%	0.0%
PHF	0.000	0.000	0.000	0.000	0.000	0.889	0.978	0.000	0.000	0.949	0.000	0.000	0.885	0.947	0.771	0.000	0.896	0.000	0.000	0.000	0.000	0.000	0.000	0.874	0.812	0.250	0.911	0.000	0.000	0.921
Lights	0	0	0	0	0	325	219	0	0	544	0	0	129	70	37	0	236	0	0	0	0	0	0	517	299	1	817	0	0	1597
% Lights	0.0%	0.0%	0.0%	0.0%	0.0%	99.4%	96.5%	0.0%	0.0%	98.2%	0.0%	0.0%	98.5%	97.2%	100.0%	0.0%	98.3%	0.0%	0.0%	0.0%	0.0%	0.0%	0.0%	95.4%	99.0%	100.0%	96.7%	0.0%	0.0%	97.4%
Trucks	0	0	0	0	0	1	0	0	0	1	0	0	1	0	0	0	1	0	0	0	0	0	0	1	0	0	1	0	0	3
% Trucks	0.0%	0.0%	0.0%	0.0%	0.0%	0.3%	0.0%	0.0%	0.0%	0.2%	0.0%	0.0%	0.8%	0.0%	0.0%	0.0%	0.4%	0.0%	0.0%	0.0%	0.0%	0.0%	0.0%	0.2%	0.0%	0.0%	0.1%	0.0%	0.0%	0.2%
Buses	0	0	0	0	0	1	8	0	0	9	0	0	1	2	0	0	3	0	0	0	0	0	0	24	3	0	27	0	0	39
% Buses	0.0%	0.0%	0.0%	0.0%	0.0%	0.3%	3.5%	0.0%	0.0%	0.0%	0.0%	0.0%	0.8%	2.8%	0.0%	0.0%	0.0%	0.0%	0.0%	0.0%	0.0%	0.0%	0.0%	4.4%	1.0%	0.0%	0.0%	0.0%	0.0%	2.4%
Pedestrians	0	0	0	0	0	0	0	0	0	0	0	0	0	0	0	0	3	3	0	0	0	6	0	0	0	0	0	1	0	4
% Pedestrians	0.0%	0.0%	0.0%	0.0%	0.0%	0.0%	0.0%	0.0%	0.0%	0.0%	0.0%	0.0%	0.0%	0.0%	0.0%	0.0%	0.0%	100.0%	100.0%	0.0%	0.0%	0.0%	0.0%	0.0%	0.0%	0.0%	0.0%	100.0%	0.0%	0.0%
Bicycles on Crosswalk	0	0	0	0	0	0	0	0	0	0	0	0	0	0	0	0	0	0	0	0	0	0	0	0	0	0	0	0	0	0
% Bicycles on Crosswalk	0.0%	0.0%	0.0%	0.0%	0.0%	0.0%	0.0%	0.0%	0.0%	0.0%	0.0%	0.0%	0.0%	0.0%	0.0%	0.0%	0.0%	0.0%	0.0%	0.0%	0.0%	0.0%	0.0%	0.0%	0.0%	0.0%	0.0%	0.0%	0.0%	0.0%

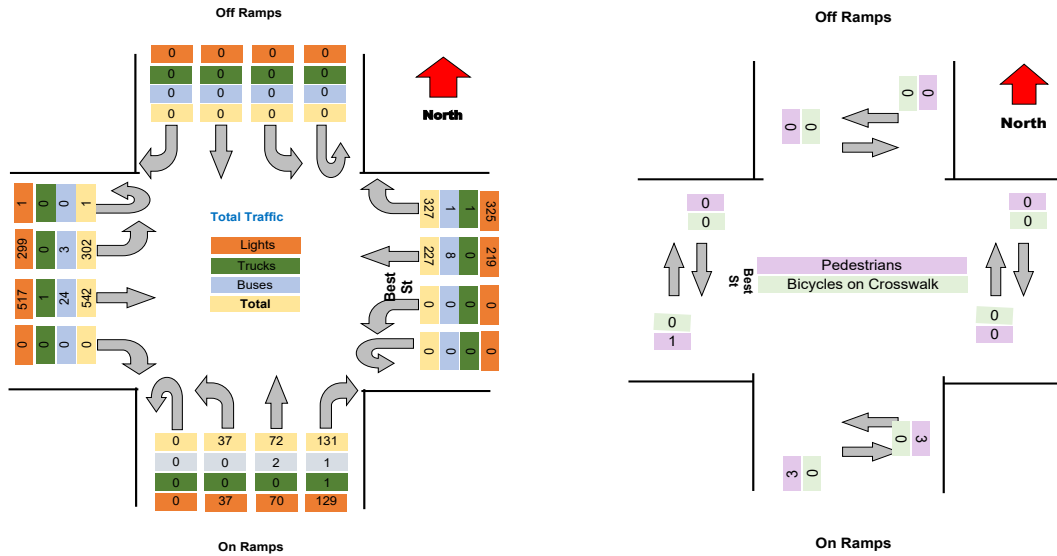



Project : VBH Malta NY  
Site : Site 4  
Location : 42.948550, -73.790036

TSTData.com

Survey Date : 2021-04-28, Wednesday

Project, Project Code, Site Name, Legs and Movements, Bin Size, Survey Date, Location, Latitude and Longitude

Forced Peak AM, Forced Peak PM, AM Peak, PM Peak

Turning Movement Data

Large table with columns for Leg, Direction, Off Ramps, Best St, On Ramps, and various traffic metrics. Includes sub-sections for Southbound, Westbound, Northbound, and Eastbound.

Project : VBH Malta NY  
 Site : Site 4  
 Location : 42.948550, -73.790036  
 Survey Date : 2021-04-28, Wednesday

### Turning Movement Data Plot

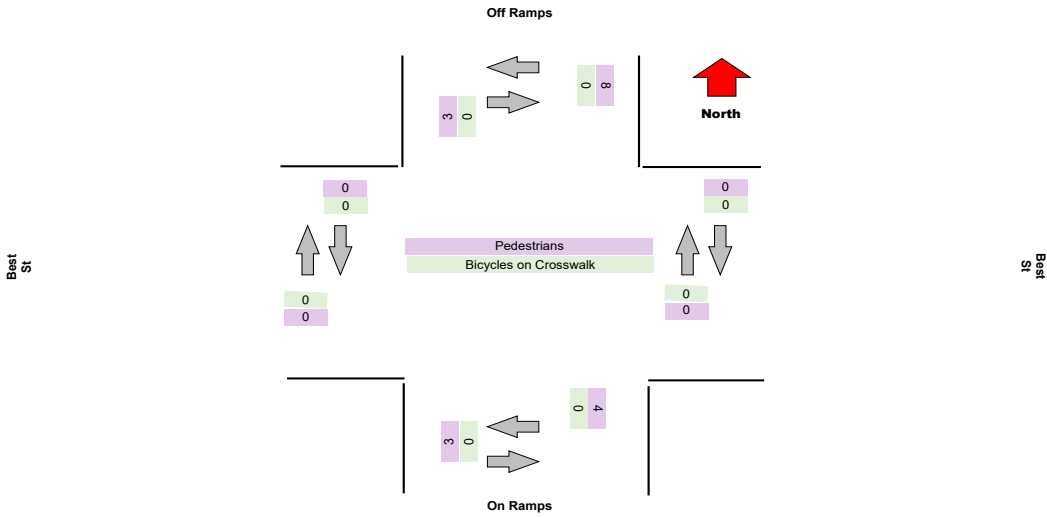
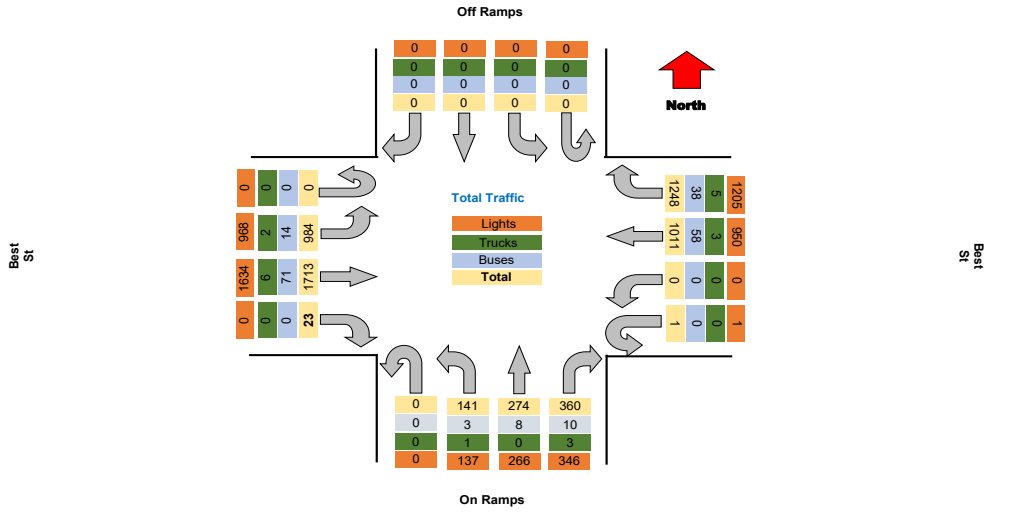

Project : VBH Malta NY  
Site : Site 4  
Location : 42.948550, -73.790036

TSTData.com

Survey Date : 2021-04-28, Wednesday

### Turning Movement Peak Hour Data (AM)

7:30:00 AM

Leg Direction	Off Ramps								Best St								On Ramps								Best St								Total
	Southbound				Westbound				Northbound				Eastbound				Northbound				Eastbound												
Start Time	Right	Thru	Left	U-Turn	App Total	Peds CW	Peds CCW		Right	Thru	Left	U-Turn	App Total	Peds CW	Peds CCW		Right	Thru	Left	U-Turn	App Total	Peds CW	Peds CCW		Right	Thru	Left	U-Turn	App Total	Peds CW	Peds CCW		
7:30:00 AM	0	0	0	0	0	0	0		54	67	0	0	121	0	0		23	16	10	0	49	0	0		0	106	70	0	176	0	0		346
7:45:00 AM	0	0	0	0	0	1	0		64	92	0	0	156	0	0		29	22	10	0	61	0	0		0	117	80	0	197	0	0		414
8:00:00 AM	0	0	0	0	0	2	0		73	53	0	0	126	0	0		30	9	14	0	53	2	2		0	114	74	0	188	0	0		379
8:15:00 AM	0	0	0	0	0	1	0		51	60	0	0	112	0	0		25	13	13	0	52	0	0		0	103	67	0	170	0	0		334
<b>Grand Total</b>	<b>0</b>	<b>0</b>	<b>0</b>	<b>0</b>	<b>0</b>	<b>1</b>	<b>0</b>		<b>282</b>	<b>302</b>	<b>0</b>	<b>0</b>	<b>587</b>	<b>0</b>	<b>0</b>		<b>108</b>	<b>60</b>	<b>47</b>	<b>0</b>	<b>215</b>	<b>2</b>	<b>2</b>		<b>0</b>	<b>440</b>	<b>291</b>	<b>0</b>	<b>731</b>	<b>0</b>	<b>0</b>		<b>1533</b>
% Approach	#DIV/0!	#DIV/0!	#DIV/0!	#DIV/0!	0.0%	0.0%	0.0%		14.2%	85.8%	0.0%	0.0%	0.0%	0.0%	0.0%		45.1%	41.7%	13.2%	0.0%	0.0%	0.0%	0.0%		0.0%	66.2%	33.8%	0.0%	0.0%	0.0%	0.0%		
% Total	0.0%	0.0%	0.0%	0.0%	0.0%	0.0%	0.0%		18.4%	19.7%	0.0%	0.0%	38.3%	0.0%	0.0%		7.0%	3.9%	3.1%	0.0%	14.0%	0.0%	0.0%		0.0%	28.7%	19.0%	0.0%	47.7%	0.0%	0.0%		
PHF	0.000	0.000	0.000	0.000	0.000	0.000	0.000		0.775	0.821	0.000	0.000	0.853	0.000	0.000		0.900	0.682	0.839	0.000	0.881	0.000	0.000		0.000	0.840	0.909	0.000	0.928	0.000	0.000		0.926
Lights	0	0	0	0	0	0	0		276	280	0	0	556	0	0		101	56	44	0	201	0	0		0	428	284	0	712	0	0		1469
% Lights	0.0%	0.0%	0.0%	0.0%	0.0%	0.0%	0.0%		97.9%	92.7%	0.0%	0.0%	94.7%	0.0%	0.0%		93.5%	93.3%	93.6%	0.0%	93.5%	0.0%	0.0%		0.0%	97.3%	97.6%	0.0%	97.4%	0.0%	0.0%		
Trucks	0	0	0	0	0	0	0		3	2	0	0	5	0	0		2	0	1	0	3	0	0		0	2	1	0	3	0	0		11
% Trucks	0.0%	0.0%	0.0%	0.0%	0.0%	0.0%	0.0%		1.1%	0.7%	0.0%	0.0%	0.9%	0.0%	0.0%		1.9%	0.0%	2.1%	0.0%	1.4%	0.0%	0.0%		0.0%	0.5%	0.3%	0.0%	0.4%	0.0%	0.0%		
Buses	0	0	0	0	0	0	0		3	20	0	0	23	0	0		5	4	2	0	11	0	0		0	10	6	0	16	0	0		50
% Buses	0.0%	0.0%	0.0%	0.0%	0.0%	0.0%	0.0%		1.1%	6.6%	0.0%	0.0%	0.0%	0.0%	0.0%		4.6%	6.7%	4.3%	0.0%	0.0%	0.0%	0.0%		0.0%	2.3%	2.1%	0.0%	0.0%	0.0%	0.0%		
Pedestrians	0	0	0	0	0	1	0		0	0	0	0	0	0	0		0	0	0	0	2	2	0		0	0	0	0	0	0	0		0
% Pedestrians	0.0%	0.0%	0.0%	0.0%	0.0%	100.0%	100.0%		0.0%	0.0%	0.0%	0.0%	0.0%	0.0%	0.0%		0.0%	0.0%	0.0%	0.0%	0.0%	100.0%	100.0%		0.0%	0.0%	0.0%	0.0%	0.0%	0.0%	0.0%		
Bicycles on Crosswalk	0	0	0	0	0	0	0		0	0	0	0	0	0	0		0	0	0	0	0	0	0		0	0	0	0	0	0	0		0
% Bicycles on Crosswalk	0.0%	0.0%	0.0%	0.0%	0.0%	0.0%	0.0%		0.0%	0.0%	0.0%	0.0%	0.0%	0.0%	0.0%		0.0%	0.0%	0.0%	0.0%	0.0%	0.0%	0.0%		0.0%	0.0%	0.0%	0.0%	0.0%	0.0%	0.0%		

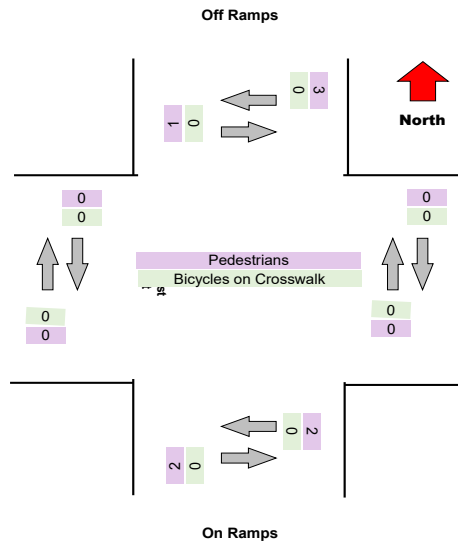
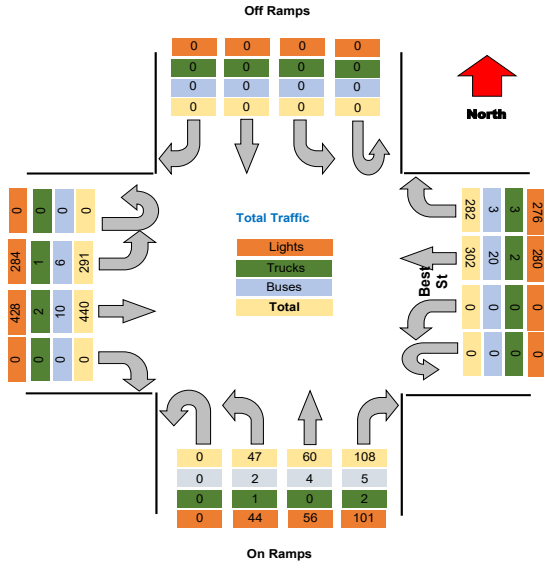



**Turning Movement Peak Hour Data (PM)**

4:30:00 PM

Leg Direction	Off Ramps										Best St										On Ramps										Best St										Total
	Southbound					Westbound					Northbound					Eastbound																									
	Right	Thru	Left	U-Turn	App Total	Right	Thru	Left	U-Turn	App Total	Right	Thru	Left	U-Turn	App Total	Right	Thru	Left	U-Turn	App Total																					
4:30:00 PM	0	0	0	0	0	114	65	0	0	179	30	22	3	0	55	1	0	0	0	1	0	154	83	0	237	0	0	0	0	0	471										
4:45:00 PM	0	0	0	0	0	104	66	0	0	170	24	19	13	0	56	1	0	0	0	1	0	134	80	0	214	0	0	0	0	0	440										
5:00:00 PM	0	0	0	0	0	93	74	0	1	168	22	23	9	0	54	0	0	0	0	0	0	124	75	0	199	0	0	0	0	0	421										
5:15:00 PM	0	0	0	0	0	96	71	0	0	167	27	26	10	0	63	0	0	0	0	0	0	128	59	0	187	0	0	0	0	0	417										
<b>Grand Total</b>	0	0	0	0	0	407	276	0	1	684	103	90	35	0	228	2	0	0	0	2	0	540	297	0	837	0	0	0	0	0	1749										
% Approach	#DIV/0!	#DIV/0!	#DIV/0!	#DIV/0!	0.0%	14.2%	85.8%	0.0%	0.0%	0.0%	45.1%	41.7%	13.2%	0.0%	0.0%	0.0%	66.2%	33.8%	0.0%	0.0%	0.0%	66.2%	33.8%	0.0%	0.0%	0.0%	0.0%	0.0%	0.0%	0.0%											
% Total	0.0%	0.0%	0.0%	0.0%	0.0%	23.3%	15.8%	0.0%	0.1%	38.1%	5.9%	5.1%	2.0%	0.0%	13.0%	0.0%	30.9%	17.0%	0.0%	47.9%	0.0%	30.9%	17.0%	0.0%	47.9%	0.0%	0.0%	0.0%	0.0%	0.0%											
PHF	0.000	0.000	0.000	0.000	0.000	0.893	0.932	0.000	0.250	0.955	0.858	0.865	0.673	0.000	0.905	0.000	0.877	0.895	0.000	0.883	0.000	0.800	0.800	0.000	0.800	0.000	0.000	0.000	0.000	0.928											
Lights	0	0	0	0	0	404	271	0	1	676	101	88	35	0	224	0	0	0	0	0	0	513	293	0	806	0	0	0	0	0	1706										
% Lights	0.0%	0.0%	0.0%	0.0%	0.0%	89.3%	98.2%	0.0%	100.0%	98.8%	98.1%	97.8%	100.0%	0.0%	98.2%	0.0%	95.0%	98.7%	0.0%	96.3%	0.0%	95.0%	98.7%	0.0%	96.3%	0.0%	0.0%	0.0%	0.0%	97.5%											
Trucks	0	0	0	0	0	1	0	0	0	1	0	0	0	0	0	0	0	1	0	1	0	0	1	0	1	0	0	0	0	2											
% Trucks	0.0%	0.0%	0.0%	0.0%	0.0%	0.2%	0.0%	0.0%	0.0%	0.1%	0.0%	0.0%	0.0%	0.0%	0.0%	0.0%	0.0%	0.3%	0.0%	0.1%	0.0%	0.0%	0.3%	0.0%	0.1%	0.0%	0.0%	0.0%	0.0%	0.1%											
Buses	0	0	0	0	0	2	5	0	0	7	1	2	0	0	3	0	0	0	0	0	0	26	3	0	29	0	0	0	0	39											
% Buses	0.0%	0.0%	0.0%	0.0%	0.0%	0.5%	1.8%	0.0%	0.0%	0.0%	1.0%	2.2%	0.0%	0.0%	0.0%	0.0%	4.8%	1.0%	0.0%	0.0%	0.0%	4.8%	1.0%	0.0%	0.0%	0.0%	0.0%	0.0%	0.0%	2.2%											
Pedestrians	0	0	0	0	0	0	0	0	0	0	0	0	0	0	0	2	0	0	0	2	0	0	0	0	0	0	0	0	0	0											
% Pedestrians	0.0%	0.0%	0.0%	0.0%	0.0%	0.0%	0.0%	0.0%	0.0%	0.0%	0.0%	0.0%	0.0%	0.0%	0.0%	0.9%	100.0%	0.0%	0.0%	0.9%	0.0%	0.0%	0.0%	0.0%	0.0%	0.0%	0.0%	0.0%	0.0%	0.0%											
Bicycles on Crosswalk	0	0	0	0	0	0	0	0	0	0	0	0	0	0	0	0	0	0	0	0	0	0	0	0	0	0	0	0	0	0											
% Bicycles on Crosswalk	0.0%	0.0%	0.0%	0.0%	0.0%	0.0%	0.0%	0.0%	0.0%	0.0%	0.0%	0.0%	0.0%	0.0%	0.0%	0.0%	0.0%	0.0%	0.0%	0.0%	0.0%	0.0%	0.0%	0.0%	0.0%	0.0%	0.0%	0.0%	0.0%	0.0%											

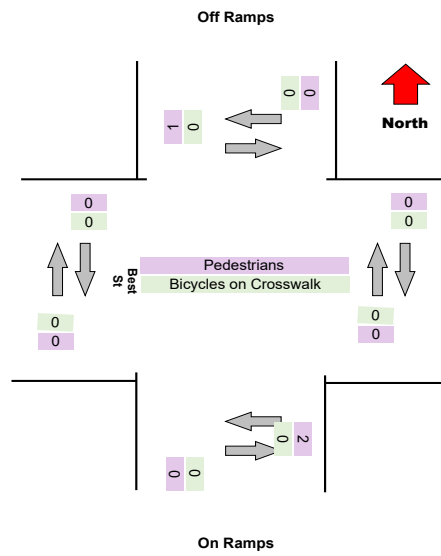
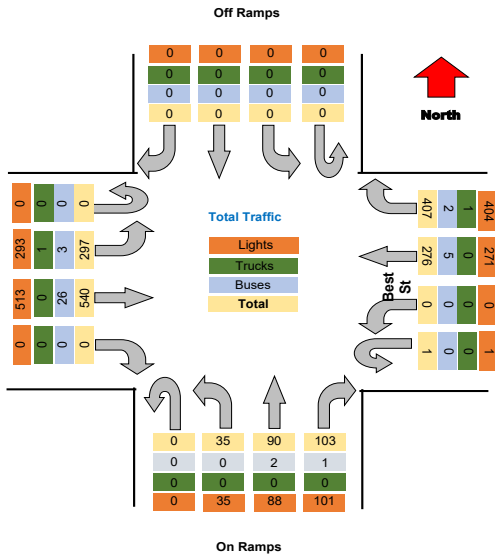



Project : VBH Malta NY  
 Site : Site 4  
 Location : 42.948550, -73.790036  
 Survey Date : 2021-04-28, Wednesday

### Turning Movement Data Plot

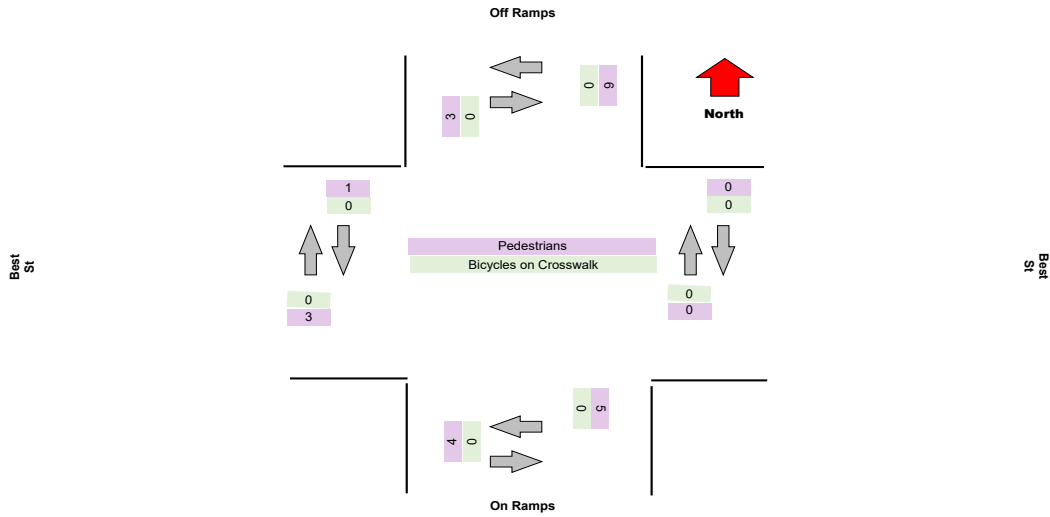
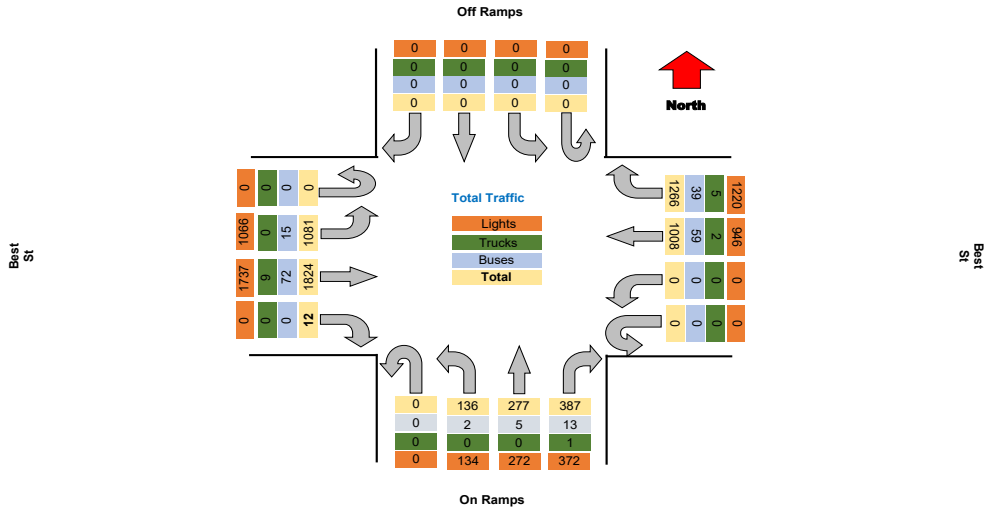

Project : VBH Malta NY  
Site : Site 4  
Location : 42.948550, -73.790036

TSTData.com

Survey Date : 2021-04-28, Wednesday

### Turning Movement Peak Hour Data (AM)

7:30:00 AM

Leg Direction	Off Ramps							Best St							On Ramps							Best St							Total
	Southbound				Westbound			Northbound				Eastbound			Northbound				Eastbound										
Start Time	Right	Thru	Left	U-Turn	App Total	Peds CW	Peds CCW	Right	Thru	Left	U-Turn	App Total	Peds CW	Peds CCW	Right	Thru	Left	U-Turn	App Total	Peds CW	Peds CCW	Right	Thru	Left	U-Turn	App Total	Peds CW	Peds CCW	
7:30:00 AM	0	0	0	0	0	1	1	47	69	0	0	117	0	0	12	12	8	0	32	0	0	0	89	60	0	149	1	0	298
7:45:00 AM	0	0	0	0	0	0	1	72	78	0	0	151	0	0	40	12	7	0	59	0	0	0	124	78	0	202	1	0	412
8:00:00 AM	0	0	0	0	0	0	0	82	69	0	0	151	0	0	39	12	11	0	62	0	1	0	126	78	0	204	0	0	417
8:15:00 AM	0	0	0	0	0	0	1	66	70	0	0	137	0	0	20	15	8	0	43	0	0	0	106	72	0	178	0	0	358
Grand Total	0	0	0	0	0	1	1	267	286	0	0	556	0	0	111	51	34	0	196	0	1	0	445	288	0	733	2	0	1485
% Approach	#DIV/0!	#DIV/0!	#DIV/0!	#DIV/0!	0.0%	0.0%	0.0%	14.2%	85.8%	0.0%	0.0%	0.0%	0.0%	0.0%	45.1%	41.7%	13.2%	0.0%	0.0%	0.0%	0.0%	0.0%	66.2%	33.8%	0.0%	0.0%	0.0%	0.0%	
% Total	0.0%	0.0%	0.0%	0.0%	0.0%	0.0%	0.0%	18.0%	19.3%	0.0%	0.0%	37.4%	0.0%	0.0%	7.5%	3.4%	2.3%	0.0%	13.2%	0.0%	0.0%	0.0%	30.0%	19.4%	0.0%	49.4%	0.0%	0.0%	
PHF	0.000	0.000	0.000	0.000	0.000	0.000	0.000	0.814	0.917	0.000	0.000	0.921	0.000	0.000	0.694	0.850	0.773	0.000	0.790	0.000	0.000	0.000	0.883	0.923	0.000	0.898	0.000	0.000	
Lights	0	0	0	0	0	0	0	261	267	0	0	528	0	0	106	48	32	0	186	0	0	0	437	281	0	718	0	0	
% Lights	0.0%	0.0%	0.0%	0.0%	0.0%	0.0%	0.0%	87.8%	93.4%	0.0%	0.0%	95.0%	0.0%	0.0%	85.5%	94.1%	94.1%	0.0%	94.9%	0.0%	0.0%	0.0%	98.2%	97.6%	0.0%	98.0%	0.0%	0.0%	
Trucks	0	0	0	0	0	0	0	1	0	0	0	1	0	0	1	0	0	0	1	0	0	0	3	0	0	3	0	0	
% Trucks	0.0%	0.0%	0.0%	0.0%	0.0%	0.0%	0.0%	0.4%	0.0%	0.0%	0.0%	0.2%	0.0%	0.0%	0.9%	0.0%	0.0%	0.0%	0.5%	0.0%	0.0%	0.0%	0.7%	0.0%	0.0%	0.4%	0.0%	0.0%	
Buses	0	0	0	0	0	0	0	5	19	0	0	24	0	0	4	3	2	0	9	0	0	0	5	7	0	12	0	0	
% Buses	0.0%	0.0%	0.0%	0.0%	0.0%	0.0%	0.0%	1.9%	6.6%	0.0%	0.0%	0.0%	0.0%	0.0%	3.6%	5.9%	5.9%	0.0%	0.0%	0.0%	0.0%	0.0%	1.1%	2.4%	0.0%	0.0%	0.0%	0.0%	
Pedestrians	0	0	0	0	0	1	1	0	0	0	0	0	0	0	0	0	0	0	0	0	1	0	0	0	0	0	2	0	
% Pedestrians	0.0%	0.0%	0.0%	0.0%	0.0%	100.0%	100.0%	0.0%	0.0%	0.0%	0.0%	0.0%	0.0%	0.0%	0.0%	0.0%	0.0%	0.0%	0.0%	0.0%	100.0%	0.0%	0.0%	0.0%	0.0%	0.0%	100.0%	0.0%	
Bicycles on Crosswalk	0	0	0	0	0	0	0	0	0	0	0	0	0	0	0	0	0	0	0	0	0	0	0	0	0	0	0	0	
% Bicycles on Crosswalk	0.0%	0.0%	0.0%	0.0%	0.0%	0.0%	0.0%	0.0%	0.0%	0.0%	0.0%	0.0%	0.0%	0.0%	0.0%	0.0%	0.0%	0.0%	0.0%	0.0%	0.0%	0.0%	0.0%	0.0%	0.0%	0.0%	0.0%	0.0%	

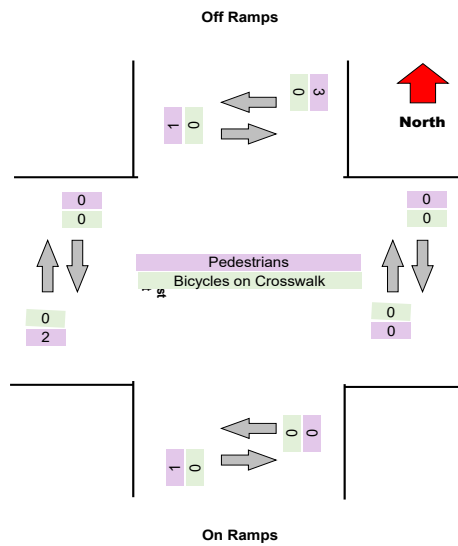
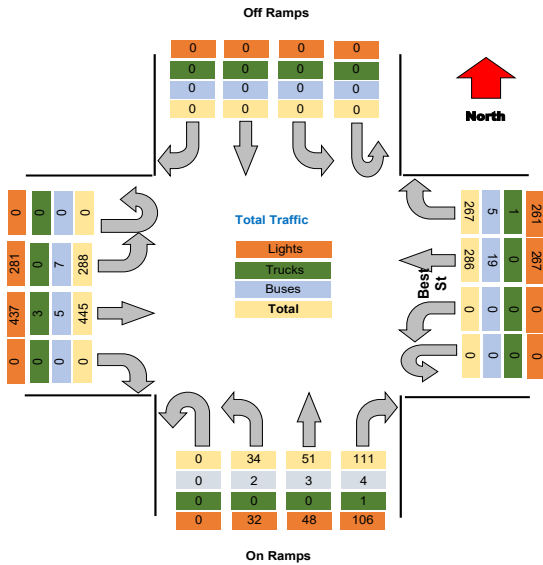

**Turning Movement Peak Hour Data (PM)**

4:30:00 PM

Leg Direction	Off Ramps										Best St						On Ramps						Best St						Total				
	Southbound					Westbound					Northbound			Eastbound			Northbound			Eastbound													
	Right	Thru	Left	U-Turn	App Total	Right	Thru	Left	U-Turn	App Total	Right	Thru	Left	Right	Thru	Left	Right	Thru	Left	Right	Thru	Left	Right	Thru	Left	Right	Thru	Left		U-Turn	App Total	Peds CW	Peds CCW
4:30:00 PM	0	0	0	0	0	129	63	0	0	192	0	0	0	36	38	8	0	82	3	0	0	0	131	83	0	214	0	0	0	0	0	0	0
4:45:00 PM	0	0	0	0	0	94	80	0	0	174	0	0	0	27	19	9	0	55	1	1	1	0	155	75	0	230	0	0	0	0	0	0	0
5:00:00 PM	0	0	0	0	0	89	57	0	0	146	0	0	0	27	14	9	0	50	0	0	0	0	148	79	0	227	0	0	0	0	0	0	0
5:15:00 PM	0	0	0	0	0	83	77	0	0	160	0	0	0	25	30	7	0	62	0	0	0	0	126	111	0	237	0	0	0	0	0	0	0
<b>Grand Total</b>	<b>0</b>	<b>0</b>	<b>0</b>	<b>0</b>	<b>0</b>	<b>395</b>	<b>277</b>	<b>0</b>	<b>0</b>	<b>672</b>	<b>0</b>	<b>0</b>	<b>0</b>	<b>115</b>	<b>101</b>	<b>33</b>	<b>0</b>	<b>249</b>	<b>4</b>	<b>1</b>	<b>1</b>	<b>0</b>	<b>558</b>	<b>344</b>	<b>0</b>	<b>902</b>	<b>0</b>	<b>0</b>	<b>0</b>	<b>0</b>	<b>0</b>	<b>0</b>	<b>0</b>
<b>% Approach</b>	#DIV/0!	#DIV/0!	#DIV/0!	#DIV/0!	0.0%	14.2%	85.8%	0.0%	0.0%	0.0%	45.1%	41.7%	13.2%	0.0%	0.0%	0.0%	66.2%	33.8%	0.0%	0.0%	0.0%	66.2%	33.8%	0.0%	0.0%	0.0%	0.0%	0.0%	0.0%	0.0%	0.0%	0.0%	
<b>% Total</b>	0.0%	0.0%	0.0%	0.0%	0.0%	21.6%	15.2%	0.0%	0.0%	36.8%	0.0%	0.0%	0.0%	6.3%	5.5%	1.8%	0.0%	13.6%	0.0%	0.0%	0.0%	0.0%	30.5%	19.0%	0.0%	49.6%	0.0%	0.0%	0.0%	0.0%	0.0%	0.0%	0.0%
<b>PHF</b>	0.000	0.000	0.000	0.000	0.000	0.766	0.866	0.000	0.000	0.875	0.000	0.000	0.000	0.799	0.664	0.917	0.000	0.759	0.000	0.000	0.000	0.000	0.900	0.784	0.000	0.956	0.000	0.000	0.000	0.000	0.000	0.000	0.000
<b>Lights</b>	0	0	0	0	0	393	271	0	0	664	0	0	0	113	101	33	0	247	0	0	0	0	522	344	0	866	0	0	0	0	0	0	0
<b>% Lights</b>	0.0%	0.0%	0.0%	0.0%	0.0%	99.5%	97.8%	0.0%	0.0%	98.8%	0.0%	0.0%	0.0%	98.3%	100.0%	100.0%	0.0%	99.2%	0.0%	0.0%	0.0%	0.0%	93.5%	98.9%	0.0%	95.6%	0.0%	0.0%	0.0%	0.0%	0.0%	0.0%	0.0%
<b>Trucks</b>	0	0	0	0	0	1	1	0	0	2	0	0	0	0	0	0	0	0	0	0	0	0	3	0	0	3	0	0	0	0	0	0	0
<b>% Trucks</b>	0.0%	0.0%	0.0%	0.0%	0.0%	0.3%	0.4%	0.0%	0.0%	0.3%	0.0%	0.0%	0.0%	0.0%	0.0%	0.0%	0.0%	0.0%	0.0%	0.5%	0.0%	0.0%	0.3%	0.0%	0.0%	0.0%	0.0%	0.0%	0.0%	0.0%			
<b>Buses</b>	0	0	0	0	0	0	4	0	0	4	0	0	0	2	0	0	0	2	0	0	0	0	30	4	0	34	0	0	0	0	0	0	0
<b>% Buses</b>	0.0%	0.0%	0.0%	0.0%	0.0%	0.0%	1.4%	0.0%	0.0%	0.6%	0.0%	0.0%	0.0%	1.7%	0.0%	0.0%	0.0%	0.8%	0.0%	0.0%	0.0%	0.0%	5.4%	1.1%	0.0%	6.6%	0.0%	0.0%	0.0%	0.0%	0.0%	0.0%	0.0%
<b>Pedestrians</b>	0	0	0	0	0	1	2	0	0	3	0	0	0	0	4	1	0	5	0	0	0	0	0	0	0	0	0	0	0	0	0	0	0
<b>% Pedestrians</b>	0.0%	0.0%	0.0%	0.0%	0.0%	100.0%	100.0%	0.0%	0.0%	0.4%	0.0%	0.0%	0.0%	0.0%	100.0%	100.0%	0.0%	2.0%	0.0%	0.0%	0.0%	0.0%	0.0%	0.0%	0.0%	0.0%	0.0%	0.0%	0.0%	0.0%	0.0%	0.0%	0.0%
<b>Bicycles on Crosswalk</b>	0	0	0	0	0	0	0	0	0	0	0	0	0	0	0	0	0	0	0	0	0	0	0	0	0	0	0	0	0	0	0	0	0
<b>% Bicycles on Crosswalk</b>	0.0%	0.0%	0.0%	0.0%	0.0%	0.0%	0.0%	0.0%	0.0%	0.0%	0.0%	0.0%	0.0%	0.0%	0.0%	0.0%	0.0%	0.0%	0.0%	0.0%	0.0%	0.0%	0.0%	0.0%	0.0%	0.0%	0.0%	0.0%	0.0%	0.0%	0.0%	0.0%	0.0%

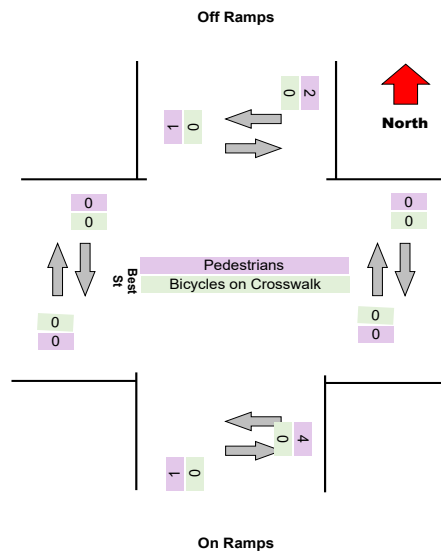
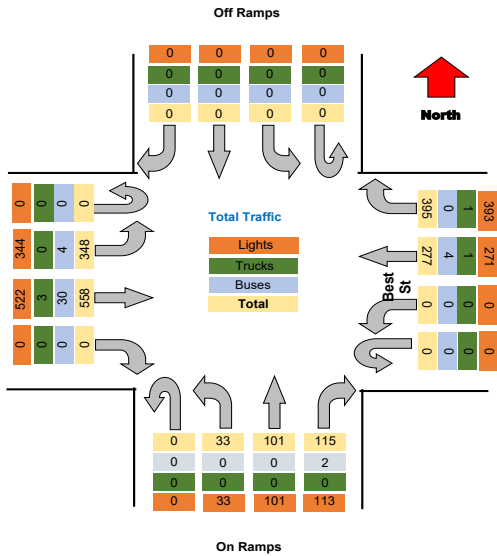

Project	1	Location	PA
Sheet	1	Date	11/11/20
Plan Title	1	Scale	
Agency	1	Client	PA Dept of Transportation
Date	11/11/20	Project No.	PA-21-001
Sheet No.	1	Sheet Title	PA-21-001

Turning Movement Data

Link	Movement 1					Movement 2					Movement 3					Movement 4				
	Opp	Thru	Right	Left	Other	Opp	Thru	Right	Left	Other	Opp	Thru	Right	Left	Other	Opp	Thru	Right	Left	Other
Link 1	100	0	0	0	0	100	0	0	0	0	100	0	0	0	0	100	0	0	0	0
Link 2	0	100	0	0	0	0	100	0	0	0	0	100	0	0	0	0	100	0	0	0
Link 3	0	0	100	0	0	0	0	100	0	0	0	0	100	0	0	0	0	100	0	0
Link 4	0	0	0	100	0	0	0	0	100	0	0	0	0	100	0	0	0	0	100	0
Link 5	100	0	0	0	0	100	0	0	0	0	100	0	0	0	0	100	0	0	0	0
Link 6	0	100	0	0	0	0	100	0	0	0	0	100	0	0	0	0	100	0	0	0
Link 7	0	0	100	0	0	0	0	100	0	0	0	0	100	0	0	0	0	100	0	0
Link 8	0	0	0	100	0	0	0	0	100	0	0	0	0	100	0	0	0	0	100	0

Turning Movement Data Plot

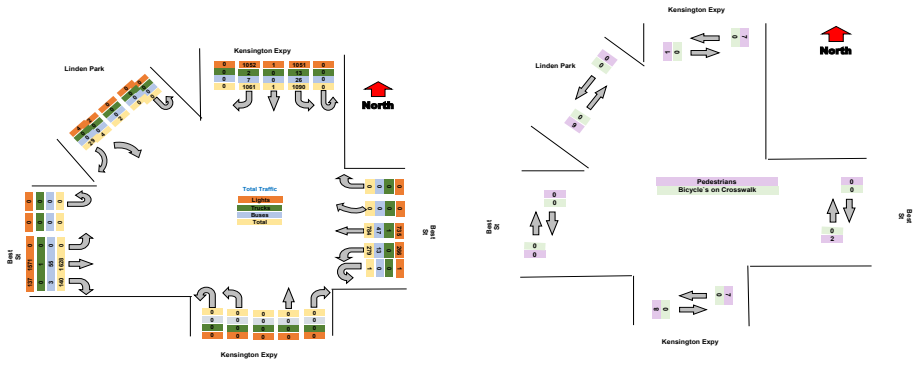



Turning Movement Peak Hour Data (AM)

7:30:00 AM

Link	Kensington Expy										Kensington Expy										Kensington Expy										Kensington Expy									
	Flow	Obs	Est	Obs	Est	Obs	Est	Obs	Est	Obs	Est	Flow	Obs	Est	Obs	Est	Flow	Obs	Est	Obs	Est	Flow	Obs	Est	Obs	Est														
Approach	1	2	3	4	5	6	7	8	9	10	11	12	13	14	15	16	17	18	19	20	21	22	23	24	25	26														
Departure	1	2	3	4	5	6	7	8	9	10	11	12	13	14	15	16	17	18	19	20	21	22	23	24	25	26														
Volume	100	100	100	100	100	100	100	100	100	100	100	100	100	100	100	100	100	100	100	100	100	100	100	100	100	100														
Delay	100	100	100	100	100	100	100	100	100	100	100	100	100	100	100	100	100	100	100	100	100	100	100	100	100	100														
Queue	100	100	100	100	100	100	100	100	100	100	100	100	100	100	100	100	100	100	100	100	100	100	100	100	100	100														
Stop	100	100	100	100	100	100	100	100	100	100	100	100	100	100	100	100	100	100	100	100	100	100	100	100	100	100														
Stop/Start	100	100	100	100	100	100	100	100	100	100	100	100	100	100	100	100	100	100	100	100	100	100	100	100	100	100														
Control	100	100	100	100	100	100	100	100	100	100	100	100	100	100	100	100	100	100	100	100	100	100	100	100	100	100														
Control/Control	100	100	100	100	100	100	100	100	100	100	100	100	100	100	100	100	100	100	100	100	100	100	100	100	100	100														

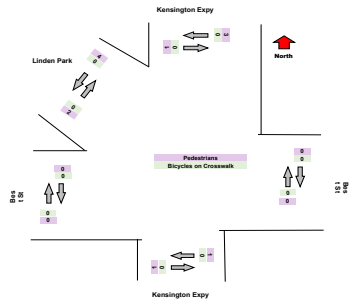
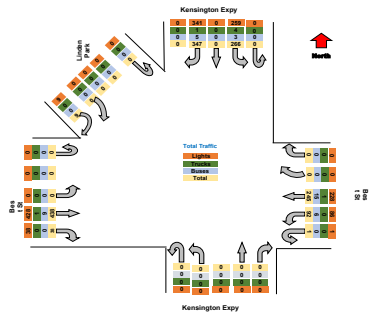



Turning Movement Peak Hour Data (PM)  
4:30:00 PM

Time	Kensington Expy										Kensington Expy										Kensington Expy										Kensington Expy																			
	1	2	3	4	5	6	7	8	9	10	11	12	13	14	15	16	17	18	19	20	21	22	23	24	25	26	27	28	29	30	31	32	33	34	35	36	37	38	39	40	41	42	43	44	45	46	47	48	49	50
Left	0	0	0	0	0	0	0	0	0	0	0	0	0	0	0	0	0	0	0	0	0	0	0	0	0	0	0	0	0	0	0	0	0	0	0	0	0	0	0	0	0	0	0	0	0	0	0	0	0	0
Thru	0	0	0	0	0	0	0	0	0	0	0	0	0	0	0	0	0	0	0	0	0	0	0	0	0	0	0	0	0	0	0	0	0	0	0	0	0	0	0	0	0	0	0	0	0	0	0	0	0	0
Right	0	0	0	0	0	0	0	0	0	0	0	0	0	0	0	0	0	0	0	0	0	0	0	0	0	0	0	0	0	0	0	0	0	0	0	0	0	0	0	0	0	0	0	0	0	0	0	0	0	0
Left	0	0	0	0	0	0	0	0	0	0	0	0	0	0	0	0	0	0	0	0	0	0	0	0	0	0	0	0	0	0	0	0	0	0	0	0	0	0	0	0	0	0	0	0	0	0	0	0	0	0
Thru	0	0	0	0	0	0	0	0	0	0	0	0	0	0	0	0	0	0	0	0	0	0	0	0	0	0	0	0	0	0	0	0	0	0	0	0	0	0	0	0	0	0	0	0	0	0	0	0	0	0
Right	0	0	0	0	0	0	0	0	0	0	0	0	0	0	0	0	0	0	0	0	0	0	0	0	0	0	0	0	0	0	0	0	0	0	0	0	0	0	0	0	0	0	0	0	0	0	0	0	0	0
Left	0	0	0	0	0	0	0	0	0	0	0	0	0	0	0	0	0	0	0	0	0	0	0	0	0	0	0	0	0	0	0	0	0	0	0	0	0	0	0	0	0	0	0	0	0	0	0	0	0	0
Thru	0	0	0	0	0	0	0	0	0	0	0	0	0	0	0	0	0	0	0	0	0	0	0	0	0	0	0	0	0	0	0	0	0	0	0	0	0	0	0	0	0	0	0	0	0	0	0	0	0	0
Right	0	0	0	0	0	0	0	0	0	0	0	0	0	0	0	0	0	0	0	0	0	0	0	0	0	0	0	0	0	0	0	0	0	0	0	0	0	0	0	0	0	0	0	0	0	0	0	0	0	0
Left	0	0	0	0	0	0	0	0	0	0	0	0	0	0	0	0	0	0	0	0	0	0	0	0	0	0	0	0	0	0	0	0	0	0	0	0	0	0	0	0	0	0	0	0	0	0	0	0	0	0
Thru	0	0	0	0	0	0	0	0	0	0	0	0	0	0	0	0	0	0	0	0	0	0	0	0	0	0	0	0	0	0	0	0	0	0	0	0	0	0	0	0	0	0	0	0	0	0	0	0	0	0
Right	0	0	0	0	0	0	0	0	0	0	0	0	0	0	0	0	0	0	0	0	0	0	0	0	0	0	0	0	0	0	0	0	0	0	0	0	0	0	0	0	0	0	0	0	0	0	0	0	0	0
Left	0	0	0	0	0	0	0	0	0	0	0	0	0	0	0	0	0	0	0	0	0	0	0	0	0	0	0	0	0	0	0	0	0	0	0	0	0	0	0	0	0	0	0	0	0	0	0	0	0	0
Thru	0	0	0	0	0	0	0	0	0	0	0	0	0	0	0	0	0	0	0	0	0	0	0	0	0	0	0	0	0	0	0	0	0	0	0	0	0	0	0	0	0	0	0	0	0	0	0	0	0	0
Right	0	0	0	0	0	0	0	0	0	0	0	0	0	0	0	0	0	0	0	0	0	0	0	0	0	0	0	0	0	0	0	0	0	0	0	0	0	0	0	0	0	0	0	0	0	0	0	0	0	0

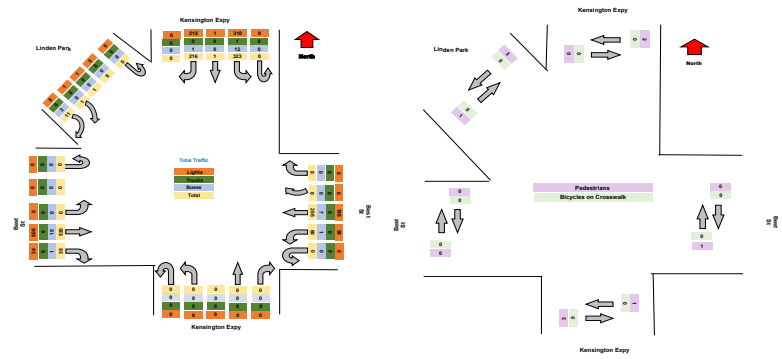

Project	1	Kennett
Project Location	2	
PRJ No	3	
Site Name	4	Kennett Square
Survey Date	5	04/28/21
Survey Time	6	11:00 AM
Survey Location	7	11/0100

  

Operator	8	TS	9
Surveyor	10	TS	11
Client	12	TS	13
Project Name	14	TS	15
Project Location	16	TS	17
Project No	18	TS	19
Project Date	20	TS	21
Project Time	22	TS	23
Project Location	24	TS	25

Turning Movement Data

CD	Westbound				Eastbound				Northbound				Southbound			
	THRU	LT	RT	OT	THRU	LT	RT	OT	THRU	LT	RT	OT	THRU	LT	RT	OT
11/0100	80	0	0	0	80	0	0	0	80	0	0	0	80	0	0	0
11/0101	80	0	0	0	80	0	0	0	80	0	0	0	80	0	0	0
11/0102	80	0	0	0	80	0	0	0	80	0	0	0	80	0	0	0
11/0103	80	0	0	0	80	0	0	0	80	0	0	0	80	0	0	0
11/0104	80	0	0	0	80	0	0	0	80	0	0	0	80	0	0	0
11/0105	80	0	0	0	80	0	0	0	80	0	0	0	80	0	0	0
11/0106	80	0	0	0	80	0	0	0	80	0	0	0	80	0	0	0
11/0107	80	0	0	0	80	0	0	0	80	0	0	0	80	0	0	0
11/0108	80	0	0	0	80	0	0	0	80	0	0	0	80	0	0	0
11/0109	80	0	0	0	80	0	0	0	80	0	0	0	80	0	0	0
11/0110	80	0	0	0	80	0	0	0	80	0	0	0	80	0	0	0
11/0111	80	0	0	0	80	0	0	0	80	0	0	0	80	0	0	0
11/0112	80	0	0	0	80	0	0	0	80	0	0	0	80	0	0	0
11/0113	80	0	0	0	80	0	0	0	80	0	0	0	80	0	0	0
11/0114	80	0	0	0	80	0	0	0	80	0	0	0	80	0	0	0
11/0115	80	0	0	0	80	0	0	0	80	0	0	0	80	0	0	0
11/0116	80	0	0	0	80	0	0	0	80	0	0	0	80	0	0	0
11/0117	80	0	0	0	80	0	0	0	80	0	0	0	80	0	0	0
11/0118	80	0	0	0	80	0	0	0	80	0	0	0	80	0	0	0
11/0119	80	0	0	0	80	0	0	0	80	0	0	0	80	0	0	0
11/0120	80	0	0	0	80	0	0	0	80	0	0	0	80	0	0	0
11/0121	80	0	0	0	80	0	0	0	80	0	0	0	80	0	0	0
11/0122	80	0	0	0	80	0	0	0	80	0	0	0	80	0	0	0
11/0123	80	0	0	0	80	0	0	0	80	0	0	0	80	0	0	0
11/0124	80	0	0	0	80	0	0	0	80	0	0	0	80	0	0	0
11/0125	80	0	0	0	80	0	0	0	80	0	0	0	80	0	0	0
11/0126	80	0	0	0	80	0	0	0	80	0	0	0	80	0	0	0
11/0127	80	0	0	0	80	0	0	0	80	0	0	0	80	0	0	0
11/0128	80	0	0	0	80	0	0	0	80	0	0	0	80	0	0	0
11/0129	80	0	0	0	80	0	0	0	80	0	0	0	80	0	0	0
11/0130	80	0	0	0	80	0	0	0	80	0	0	0	80	0	0	0
11/0131	80	0	0	0	80	0	0	0	80	0	0	0	80	0	0	0
11/0132	80	0	0	0	80	0	0	0	80	0	0	0	80	0	0	0
11/0133	80	0	0	0	80	0	0	0	80	0	0	0	80	0	0	0
11/0134	80	0	0	0	80	0	0	0	80	0	0	0	80	0	0	0
11/0135	80	0	0	0	80	0	0	0	80	0	0	0	80	0	0	0
11/0136	80	0	0	0	80	0	0	0	80	0	0	0	80	0	0	0
11/0137	80	0	0	0	80	0	0	0	80	0	0	0	80	0	0	0
11/0138	80	0	0	0	80	0	0	0	80	0	0	0	80	0	0	0
11/0139	80	0	0	0	80	0	0	0	80	0	0	0	80	0	0	0
11/0140	80	0	0	0	80	0	0	0	80	0	0	0	80	0	0	0
11/0141	80	0	0	0	80	0	0	0	80	0	0	0	80	0	0	0
11/0142	80	0	0	0	80	0	0	0	80	0	0	0	80	0	0	0
11/0143	80	0	0	0	80	0	0	0	80	0	0	0	80	0	0	0
11/0144	80	0	0	0	80	0	0	0	80	0	0	0	80	0	0	0
11/0145	80	0	0	0	80	0	0	0	80	0	0	0	80	0	0	0
11/0146	80	0	0	0	80	0	0	0	80	0	0	0	80	0	0	0
11/0147	80	0	0	0	80	0	0	0	80	0	0	0	80	0	0	0
11/0148	80	0	0	0	80	0	0	0	80	0	0	0	80	0	0	0
11/0149	80	0	0	0	80	0	0	0	80	0	0	0	80	0	0	0
11/0150	80	0	0	0	80	0	0	0	80	0	0	0	80	0	0	0

Turning Movement Data Plot

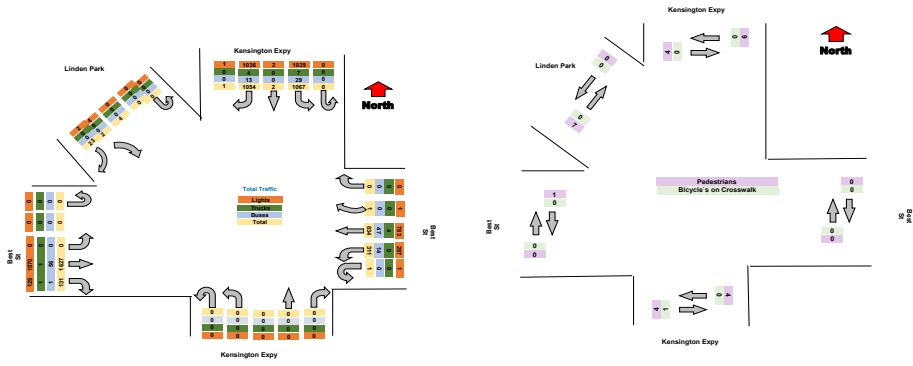

Turning Movement Peak Hour Data (AM)

7:30:00 AM

Link	Kensington Expy										Kensington Expy										Kensington Expy										Linden Park									
	Dir	Vol	WT	WT	WT	WT	WT	WT	WT	WT	Dir	Vol	WT	WT	WT	WT	WT	WT	WT	WT	Dir	Vol	WT	WT	WT	WT	WT	WT	WT	WT	Dir	Vol	WT	WT	WT	WT	WT	WT	WT	WT
Approach	...																																							
Departure	...																																							
Control	...																																							
Signal	...																																							
Phase	...																																							
Time	...																																							
Notes	...																																							
Comments	...																																							

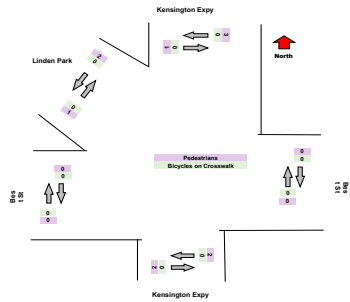
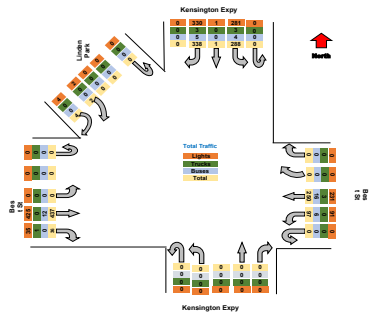

Turning Movement Peak Hour Data (PM)  
4:30:00 PM

Link	Kensington Expy				Kensington Expy				Kensington Expy				Kensington Expy			
	Left	Thru	Right	Total	Left	Thru	Right	Total	Left	Thru	Right	Total	Left	Thru	Right	Total
Link ID	101	102	103	104	105	106	107	108	109	110	111	112	113	114	115	116
Link Name	...	...	...	...	...	...	...	...	...	...	...	...	...	...	...	...
Link Type	...	...	...	...	...	...	...	...	...	...	...	...	...	...	...	...
Link Length	...	...	...	...	...	...	...	...	...	...	...	...	...	...	...	...
Link Speed	...	...	...	...	...	...	...	...	...	...	...	...	...	...	...	...
Link Volume	...	...	...	...	...	...	...	...	...	...	...	...	...	...	...	...
Link Capacity	...	...	...	...	...	...	...	...	...	...	...	...	...	...	...	...
Link Utilization	...	...	...	...	...	...	...	...	...	...	...	...	...	...	...	...

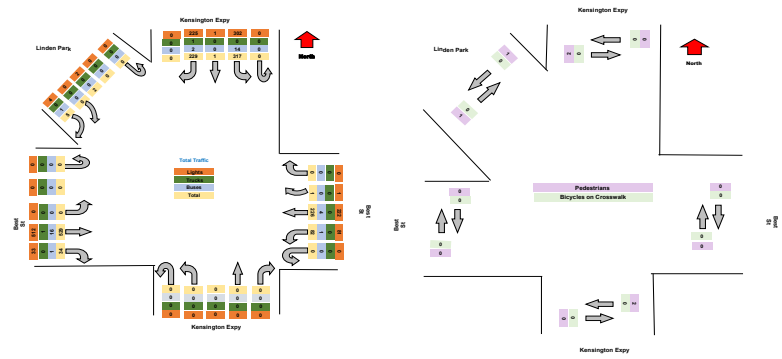

Project Name	1032010
Client	PA Dept of Transportation
Site Name	01 Kennett Square, PA
Site Address	01 Kennett Square, PA
Site City	01 Kennett Square, PA
Site State	01 PA
Site Zip	01 19348
Survey Date	04/28/2021
Survey Time	08:00 AM - 05:00 PM
Survey Duration	09:00
Survey Method	01 Manual
Survey Equipment	01 TSC2
Survey Operator	01 JTB
Survey Station	01 01

**Turning Movement Data**

IS	Movement					IS					Movement					IS
	TH	TR	LT	RT	OT	TH	TR	LT	RT	OT	TH	TR	LT	RT	OT	
1	15	10	5	15	10	15	10	5	15	10	15	10	5	15	10	
2	15	10	5	15	10	15	10	5	15	10	15	10	5	15	10	
3	15	10	5	15	10	15	10	5	15	10	15	10	5	15	10	
4	15	10	5	15	10	15	10	5	15	10	15	10	5	15	10	
5	15	10	5	15	10	15	10	5	15	10	15	10	5	15	10	
6	15	10	5	15	10	15	10	5	15	10	15	10	5	15	10	
7	15	10	5	15	10	15	10	5	15	10	15	10	5	15	10	
8	15	10	5	15	10	15	10	5	15	10	15	10	5	15	10	
9	15	10	5	15	10	15	10	5	15	10	15	10	5	15	10	
10	15	10	5	15	10	15	10	5	15	10	15	10	5	15	10	
11	15	10	5	15	10	15	10	5	15	10	15	10	5	15	10	
12	15	10	5	15	10	15	10	5	15	10	15	10	5	15	10	
13	15	10	5	15	10	15	10	5	15	10	15	10	5	15	10	
14	15	10	5	15	10	15	10	5	15	10	15	10	5	15	10	
15	15	10	5	15	10	15	10	5	15	10	15	10	5	15	10	
16	15	10	5	15	10	15	10	5	15	10	15	10	5	15	10	
17	15	10	5	15	10	15	10	5	15	10	15	10	5	15	10	
18	15	10	5	15	10	15	10	5	15	10	15	10	5	15	10	
19	15	10	5	15	10	15	10	5	15	10	15	10	5	15	10	
20	15	10	5	15	10	15	10	5	15	10	15	10	5	15	10	
21	15	10	5	15	10	15	10	5	15	10	15	10	5	15	10	
22	15	10	5	15	10	15	10	5	15	10	15	10	5	15	10	
23	15	10	5	15	10	15	10	5	15	10	15	10	5	15	10	
24	15	10	5	15	10	15	10	5	15	10	15	10	5	15	10	
25	15	10	5	15	10	15	10	5	15	10	15	10	5	15	10	
26	15	10	5	15	10	15	10	5	15	10	15	10	5	15	10	
27	15	10	5	15	10	15	10	5	15	10	15	10	5	15	10	
28	15	10	5	15	10	15	10	5	15	10	15	10	5	15	10	
29	15	10	5	15	10	15	10	5	15	10	15	10	5	15	10	
30	15	10	5	15	10	15	10	5	15	10	15	10	5	15	10	
31	15	10	5	15	10	15	10	5	15	10	15	10	5	15	10	
32	15	10	5	15	10	15	10	5	15	10	15	10	5	15	10	
33	15	10	5	15	10	15	10	5	15	10	15	10	5	15	10	
34	15	10	5	15	10	15	10	5	15	10	15	10	5	15	10	
35	15	10	5	15	10	15	10	5	15	10	15	10	5	15	10	
36	15	10	5	15	10	15	10	5	15	10	15	10	5	15	10	
37	15	10	5	15	10	15	10	5	15	10	15	10	5	15	10	
38	15	10	5	15	10	15	10	5	15	10	15	10	5	15	10	
39	15	10	5	15	10	15	10	5	15	10	15	10	5	15	10	
40	15	10	5	15	10	15	10	5	15	10	15	10	5	15	10	
41	15	10	5	15	10	15	10	5	15	10	15	10	5	15	10	
42	15	10	5	15	10	15	10	5	15	10	15	10	5	15	10	
43	15	10	5	15	10	15	10	5	15	10	15	10	5	15	10	
44	15	10	5	15	10	15	10	5	15	10	15	10	5	15	10	
45	15	10	5	15	10	15	10	5	15	10	15	10	5	15	10	
46	15	10	5	15	10	15	10	5	15	10	15	10	5	15	10	
47	15	10	5	15	10	15	10	5	15	10	15	10	5	15	10	
48	15	10	5	15	10	15	10	5	15	10	15	10	5	15	10	
49	15	10	5	15	10	15	10	5	15	10	15	10	5	15	10	
50	15	10	5	15	10	15	10	5	15	10	15	10	5	15	10	
51	15	10	5	15	10	15	10	5	15	10	15	10	5	15	10	
52	15	10	5	15	10	15	10	5	15	10	15	10	5	15	10	
53	15	10	5	15	10	15	10	5	15	10	15	10	5	15	10	
54	15	10	5	15	10	15	10	5	15	10	15	10	5	15	10	
55	15	10	5	15	10	15	10	5	15	10	15	10	5	15	10	
56	15	10	5	15	10	15	10	5	15	10	15	10	5	15	10	
57	15	10	5	15	10	15	10	5	15	10	15	10	5	15	10	
58	15	10	5	15	10	15	10	5	15	10	15	10	5	15	10	
59	15	10	5	15	10	15	10	5	15	10	15	10	5	15	10	
60	15	10	5	15	10	15	10	5	15	10	15	10	5	15	10	

Turning Movement Data Plot

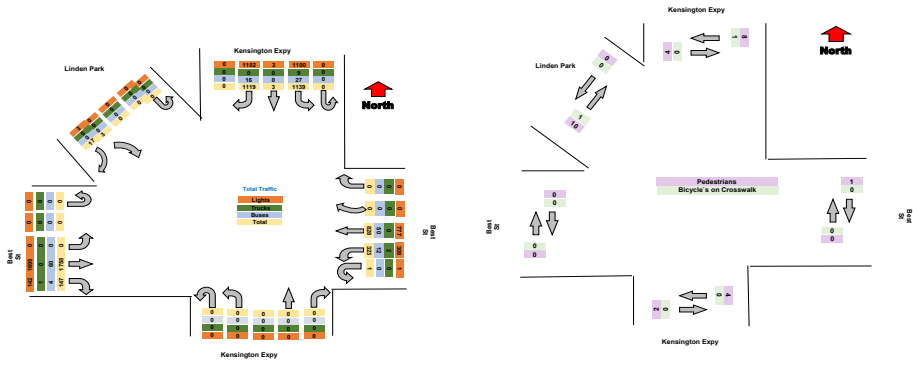



Turning Movement Peak Hour Data (AM)

7:30:00 AM

Link	Kensington Expy				North				Kensington Expy				South			
	Left	Thru	Right	Total	Left	Thru	Right	Total	Left	Thru	Right	Total	Left	Thru	Right	Total
Approach	100	100	100	300	100	100	100	300	100	100	100	300	100	100	100	300
Departure	100	100	100	300	100	100	100	300	100	100	100	300	100	100	100	300
Left	100	100	100	300	100	100	100	300	100	100	100	300	100	100	100	300
Thru	100	100	100	300	100	100	100	300	100	100	100	300	100	100	100	300
Right	100	100	100	300	100	100	100	300	100	100	100	300	100	100	100	300
Left	100	100	100	300	100	100	100	300	100	100	100	300	100	100	100	300
Thru	100	100	100	300	100	100	100	300	100	100	100	300	100	100	100	300
Right	100	100	100	300	100	100	100	300	100	100	100	300	100	100	100	300
Left	100	100	100	300	100	100	100	300	100	100	100	300	100	100	100	300
Thru	100	100	100	300	100	100	100	300	100	100	100	300	100	100	100	300
Right	100	100	100	300	100	100	100	300	100	100	100	300	100	100	100	300
Left	100	100	100	300	100	100	100	300	100	100	100	300	100	100	100	300
Thru	100	100	100	300	100	100	100	300	100	100	100	300	100	100	100	300
Right	100	100	100	300	100	100	100	300	100	100	100	300	100	100	100	300
Left	100	100	100	300	100	100	100	300	100	100	100	300	100	100	100	300
Thru	100	100	100	300	100	100	100	300	100	100	100	300	100	100	100	300
Right	100	100	100	300	100	100	100	300	100	100	100	300	100	100	100	300
Left	100	100	100	300	100	100	100	300	100	100	100	300	100	100	100	300
Thru	100	100	100	300	100	100	100	300	100	100	100	300	100	100	100	300
Right	100	100	100	300	100	100	100	300	100	100	100	300	100	100	100	300

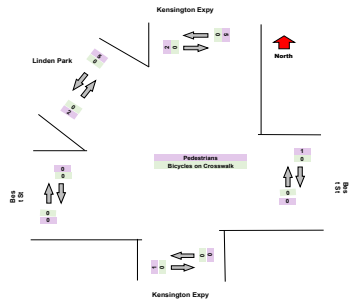
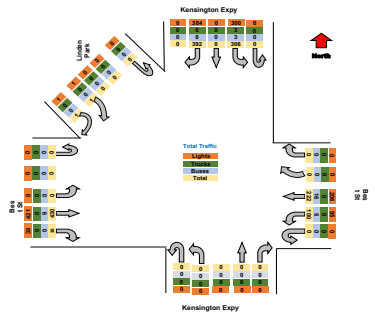



Turning Movement Peak Hour Data (PM)  
4:30:00 PM

Link	Kensington Expy				Kensington Expy				Kensington Expy				Kensington Expy			
	Left	Thru	Right	Total	Left	Thru	Right	Total	Left	Thru	Right	Total	Left	Thru	Right	Total
Left	0	0	0	0	0	0	0	0	0	0	0	0	0	0	0	0
Thru	0	0	0	0	0	0	0	0	0	0	0	0	0	0	0	0
Right	0	0	0	0	0	0	0	0	0	0	0	0	0	0	0	0
Total	0	0	0	0	0	0	0	0	0	0	0	0	0	0	0	0

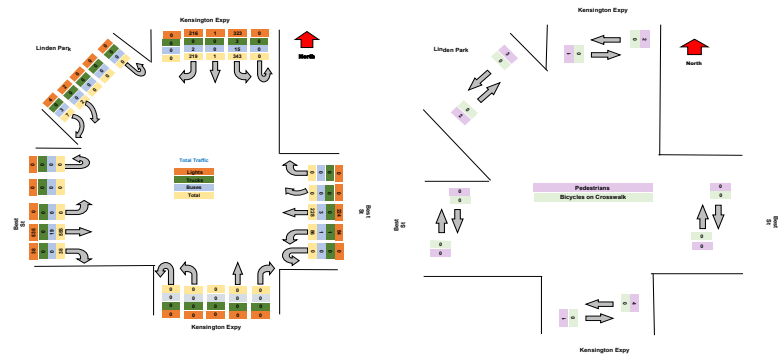



Turning Movement Data Plot

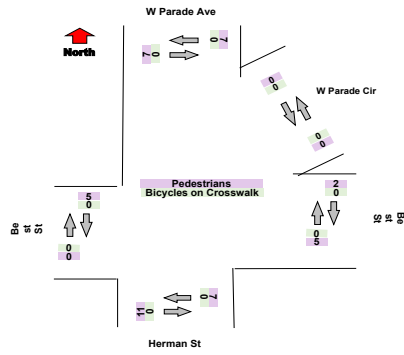
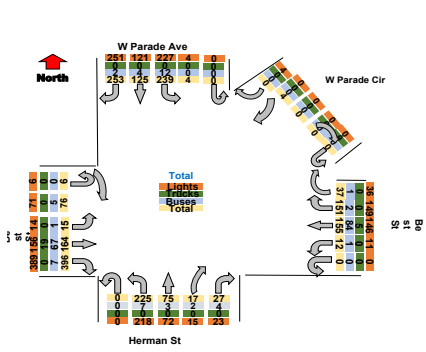

Turning Movement Peak Hour Data (AM)

7:30:00 AM

Link	W Parade Ave				Herman St				W Parade Cir				Pine St			
	Flow	Vol	Sat	Opp	Flow	Vol	Sat	Opp	Flow	Vol	Sat	Opp	Flow	Vol	Sat	Opp
W Parade Ave	1	10	0	0	1	10	0	0	1	10	0	0	1	10	0	0
Herman St	1	10	0	0	1	10	0	0	1	10	0	0	1	10	0	0
W Parade Cir	1	10	0	0	1	10	0	0	1	10	0	0	1	10	0	0
Pine St	1	10	0	0	1	10	0	0	1	10	0	0	1	10	0	0

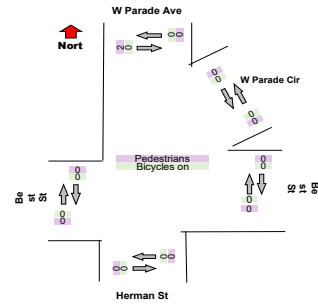
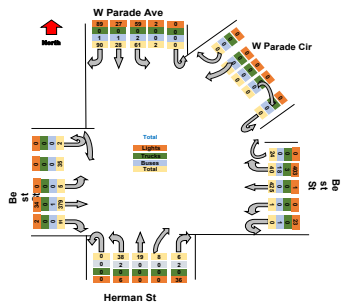

Turning Movement Peak Hour Data (PM)

4:15:00 PM

Link	W Parade Ave				Herman St				Beech St				Pine St			
	1	2	3	4	1	2	3	4	1	2	3	4	1	2	3	4
Volume	11	11	11	11	11	11	11	11	11	11	11	11	11	11	11	11
Light	11	11	11	11	11	11	11	11	11	11	11	11	11	11	11	11
Heavy	11	11	11	11	11	11	11	11	11	11	11	11	11	11	11	11
Total	11	11	11	11	11	11	11	11	11	11	11	11	11	11	11	11

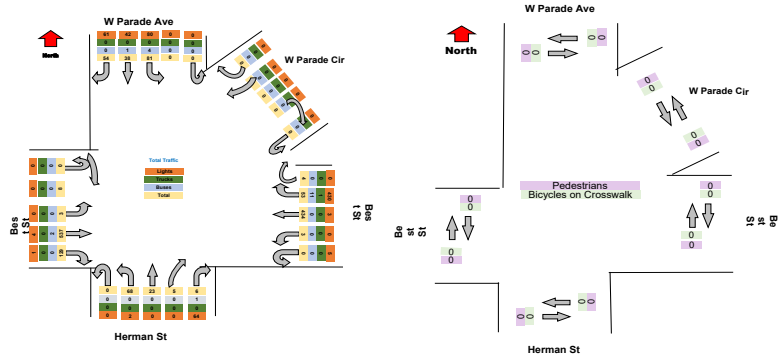



Turning Movement Data Plot

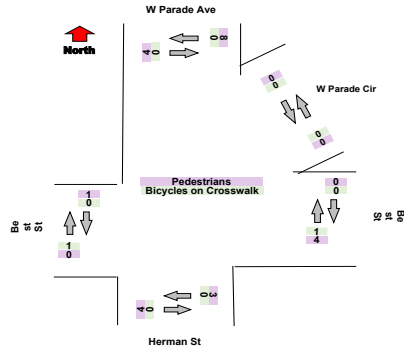
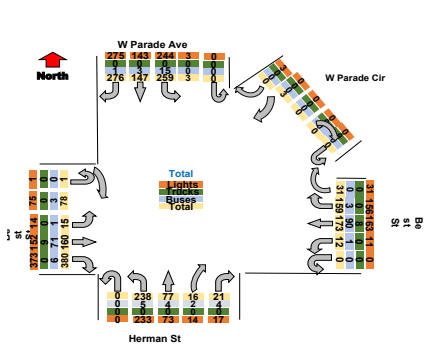

Turning Movement Peak Hour Data (AM)

7:30:00 AM

Link	W Parade Ave				Herman St				W Parade Cir				Pine St			
	Flow	Vol	Sat	Stop	Flow	Vol	Sat	Stop	Flow	Vol	Sat	Stop	Flow	Vol	Sat	Stop
W Parade Ave	1	0	0	0	1	0	0	0	1	0	0	0	1	0	0	0
Herman St	1	0	0	0	1	0	0	0	1	0	0	0	1	0	0	0
W Parade Cir	1	0	0	0	1	0	0	0	1	0	0	0	1	0	0	0
Pine St	1	0	0	0	1	0	0	0	1	0	0	0	1	0	0	0

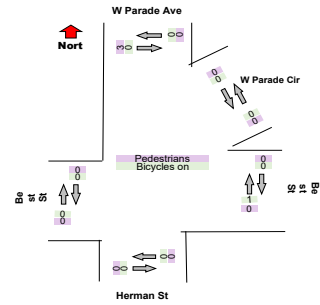
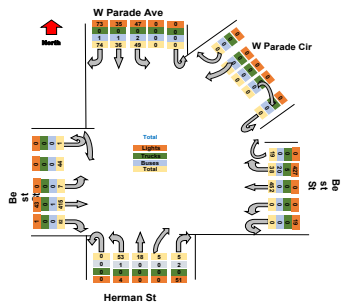



Turning Movement Peak Hour Data (PM)  
 4:15:00 PM

Link	W Parade Ave				Beech St				Herman St				Pine St			
	TH	TR	TR	TH	TH	TR	TR	TH	TH	TR	TR	TH	TR	TR	TH	
W Parade Ave	12	12	12	12	12	12	12	12	12	12	12	12	12	12	12	
Beech St	12	12	12	12	12	12	12	12	12	12	12	12	12	12	12	
Herman St	12	12	12	12	12	12	12	12	12	12	12	12	12	12	12	
Pine St	12	12	12	12	12	12	12	12	12	12	12	12	12	12	12	

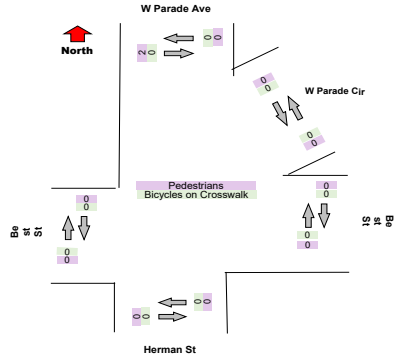
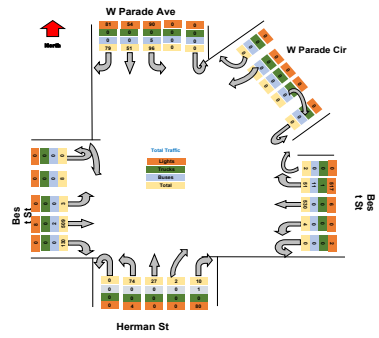



Turning Movement Data Plot

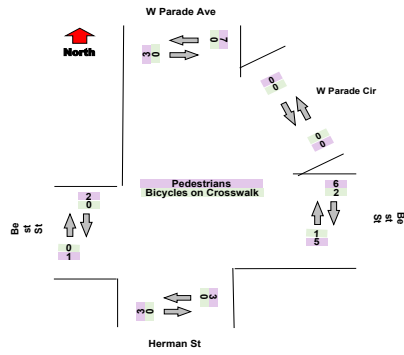
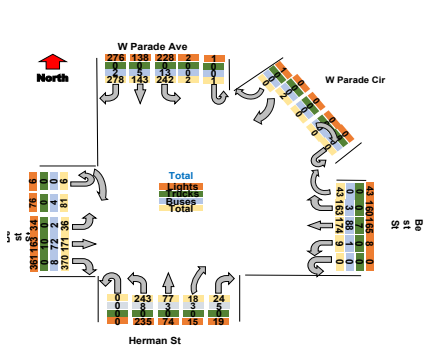

Turning Movement Peak Hour Data (AM)

7:30:00 AM

Link	W Parade Ave				Herman St				W Parade Cir				Pine St			
	Flow	Vol	Sat	Opp	Flow	Vol	Sat	Opp	Flow	Vol	Sat	Opp	Flow	Vol	Sat	Opp
W Parade Ave	1	0	0	0	1	0	0	0	1	0	0	0	1	0	0	0
Herman St	1	0	0	0	1	0	0	0	1	0	0	0	1	0	0	0
W Parade Cir	1	0	0	0	1	0	0	0	1	0	0	0	1	0	0	0
Pine St	1	0	0	0	1	0	0	0	1	0	0	0	1	0	0	0

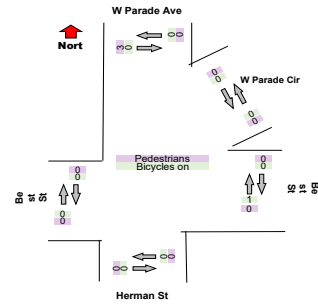
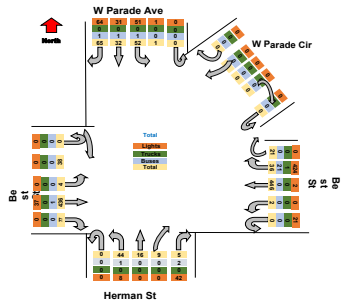

**Turning Movement Peak Hour Data (PM)**  
 4:15:00 PM

Link	Approach					Departure					Approach					Departure				
	1	2	3	4	5	1	2	3	4	5	1	2	3	4	5	1	2	3	4	5
W Parade Ave	12	12	12	12	12	12	12	12	12	12	12	12	12	12	12	12	12	12	12	12
Bos St	12	12	12	12	12	12	12	12	12	12	12	12	12	12	12	12	12	12	12	12
Herman St	12	12	12	12	12	12	12	12	12	12	12	12	12	12	12	12	12	12	12	12
W Parade Cir	12	12	12	12	12	12	12	12	12	12	12	12	12	12	12	12	12	12	12	12
Pedestrians	0	0	0	0	0	0	0	0	0	0	0	0	0	0	0	0	0	0	0	0
Bicycles	0	0	0	0	0	0	0	0	0	0	0	0	0	0	0	0	0	0	0	0

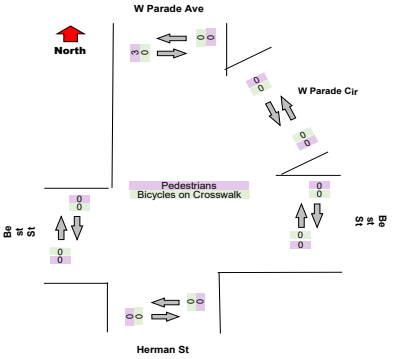
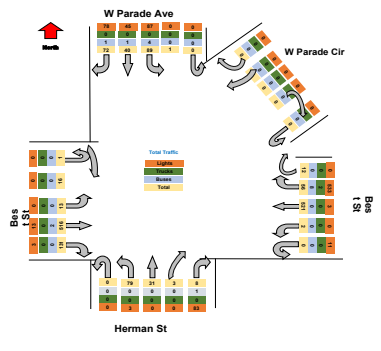



Project : VBH Malta NY  
 Site : Site 4  
 Location : 42.948550, -73.790036  
 Survey Date : 2021-04-28, Wednesday

### Turning Movement Data Plot

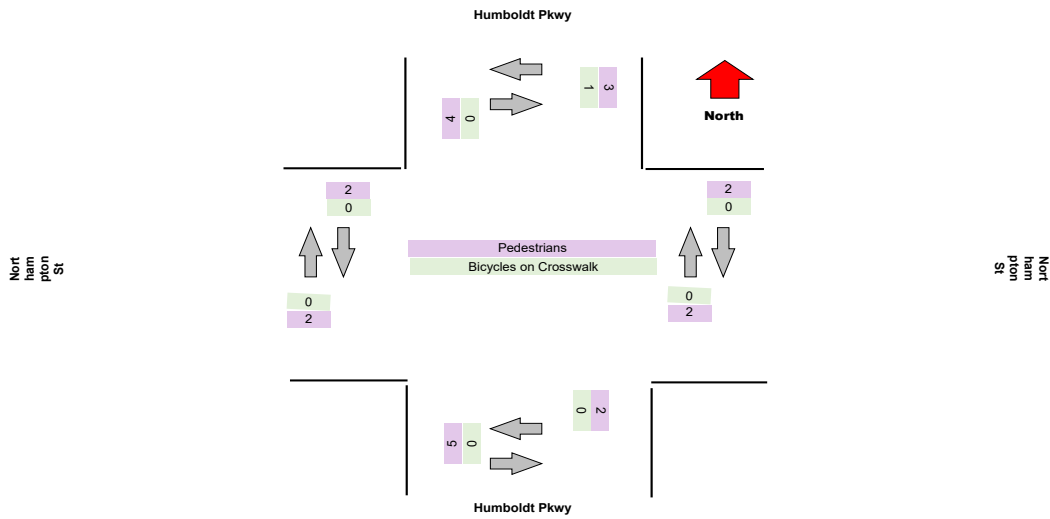
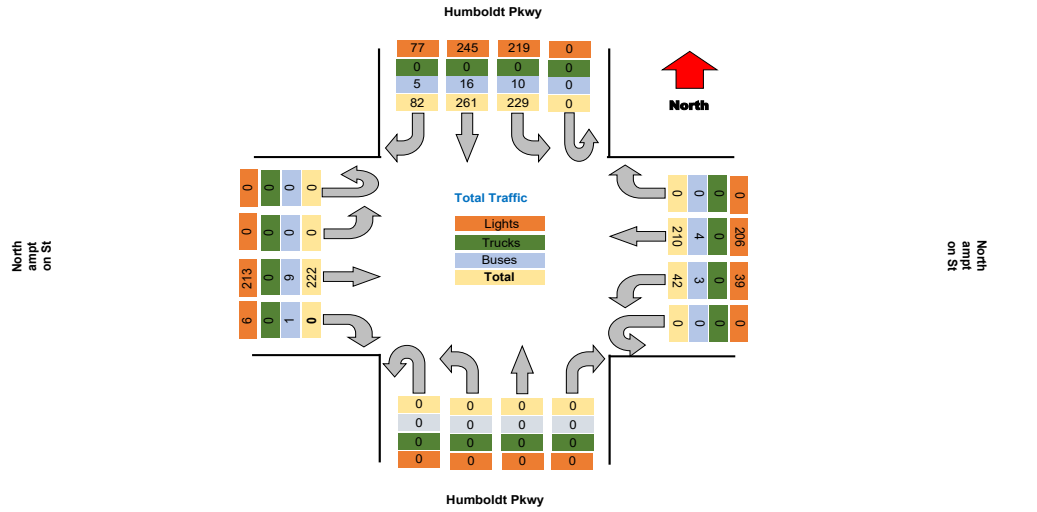

**Turning Movement Peak Hour Data (AM)**

7:30:00 AM

Leg Direction	Humboldt Pkwy						Northampton St						Humboldt Pkwy						Northampton St						Total					
	Southbound			Northbound			Westbound			Eastbound			Northbound			Eastbound														
Start Time	Right	Thru	Left	U-Turn	App Total	Peds CW	Peds CCW	Right	Thru	Left	U-Turn	App Total	Peds CW	Peds CCW	Right	Thru	Left	U-Turn	App Total	Peds CW	Peds CCW	Right	Thru	Left	U-Turn	App Total	Peds CW	Peds CCW		
7:30:00 AM	2	11	17	0	30	2	0	0	5	3	0	8	0	0	0	0	0	0	0	0	0	0	1	11	0	0	12	1	1	50
7:45:00 AM	2	21	13	0	36	0	0	0	18	4	0	22	0	0	0	0	0	0	0	0	0	0	1	13	0	0	14	0	0	72
8:00:00 AM	6	14	9	0	29	0	1	0	15	5	0	21	0	1	0	0	0	0	1	0	2	0	2	0	0	20	0	0	71	
8:15:00 AM	4	14	13	0	31	0	0	0	13	1	0	14	0	0	0	0	0	0	0	0	0	0	0	0	0	15	0	0	60	
<b>Grand Total</b>	14	60	52	0	126	2	1	0	51	13	0	65	0	1	0	0	0	0	1	2	2	2	59	0	0	61	1	1	253	
% Approach	11.1%	47.6%	41.3%	0.0%	0.0%	0.0%	0.0%	14.2%	85.8%	0.0%	0.0%	0.0%	0.0%	0.0%	45.1%	41.7%	13.2%	0.0%	0.0%	0.0%	0.0%	0.0%	0.0%	66.2%	33.8%	0.0%	0.0%	0.0%	0.0%	
% Total	5.5%	23.7%	20.6%	0.0%	48.8%	0.0%	0.0%	0.0%	20.2%	5.1%	0.0%	25.7%	0.0%	0.0%	0.0%	0.0%	0.0%	0.0%	0.4%	0.0%	0.0%	0.8%	23.3%	0.0%	0.0%	24.1%	0.0%	0.0%	6.7%	
PHF	0.583	0.714	0.765	0.000	0.875	0.000	0.000	0.000	0.708	0.650	0.000	0.739	0.000	0.000	0.000	0.000	0.000	0.250	0.000	0.000	0.500	0.738	0.000	0.000	0.763	0.000	0.000	0.878		
Lights	13	55	48	0	116	0	0	0	49	12	0	61	0	0	0	0	0	0	0	0	0	0	2	55	0	0	57	0	0	234
% Lights	82.9%	91.7%	92.3%	0.0%	92.1%	0.0%	0.0%	0.0%	96.1%	92.3%	0.0%	93.8%	0.0%	0.0%	0.0%	0.0%	0.0%	0.0%	0.0%	0.0%	0.0%	0.0%	100.0%	93.2%	0.0%	0.0%	93.4%	0.0%	0.0%	92.5%
Trucks	0	0	0	0	0	0	0	0	0	0	0	0	0	0	0	0	0	0	0	0	0	0	0	0	0	0	0	0	0	
% Trucks	0.0%	0.0%	0.0%	0.0%	0.0%	0.0%	0.0%	0.0%	0.0%	0.0%	0.0%	0.0%	0.0%	0.0%	0.0%	0.0%	0.0%	0.0%	0.0%	0.0%	0.0%	0.0%	0.0%	0.0%	0.0%	0.0%	0.0%	0.0%	0.0%	
Buses	1	5	4	0	10	0	0	0	2	1	0	3	0	0	0	0	0	0	0	0	0	0	0	4	0	0	4	0	0	17
% Buses	7.1%	8.3%	7.7%	0.0%	0.0%	0.0%	0.0%	0.0%	3.9%	7.7%	0.0%	0.0%	0.0%	0.0%	0.0%	0.0%	0.0%	0.0%	0.0%	0.0%	0.0%	0.0%	6.8%	0.0%	0.0%	0.0%	0.0%	0.0%	6.7%	
Pedestrians	0	0	0	0	0	2	0	0	0	0	0	0	1	0	0	0	0	0	0	2	3	0	0	0	0	0	0	1	1	0
% Pedestrians	0.0%	0.0%	0.0%	0.0%	0.0%	100.0%	0.0%	0.0%	0.0%	0.0%	0.0%	0.0%	0.0%	100.0%	0.0%	0.0%	0.0%	0.0%	0.0%	0.0%	100.0%	100.0%	0.0%	0.0%	0.0%	0.0%	0.0%	100.0%	100.0%	0.0%
Bicycles on Crosswalk	0	0	0	0	0	0	0	0	0	0	0	0	0	0	0	0	0	0	0	0	0	0	0	0	0	0	0	0	0	
% Bicycles on Crosswalk	0.0%	0.0%	0.0%	0.0%	0.0%	0.0%	100.0%	0.0%	0.0%	0.0%	0.0%	0.0%	0.0%	0.0%	0.0%	0.0%	0.0%	0.0%	0.0%	0.0%	0.0%	0.0%	0.0%	0.0%	0.0%	0.0%	0.0%	0.0%	0.0%	

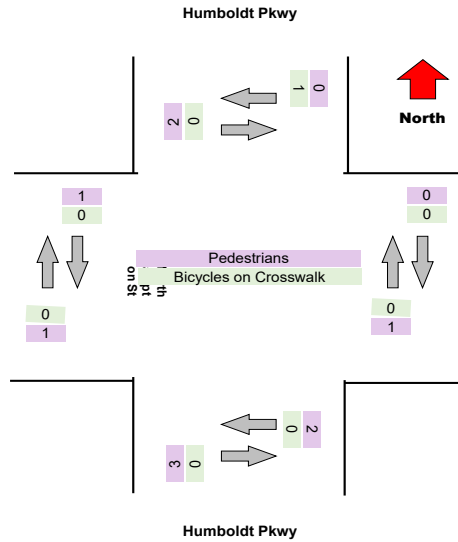
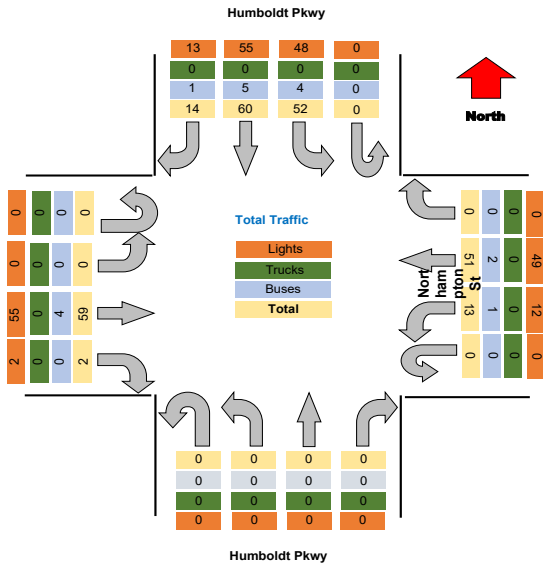



### Turning Movement Peak Hour Data (PM)

4:15:00 PM

Leg Direction	Humboldt Pkwy										Northampton St										Total				
	Southbound					Westbound					Northbound					Eastbound									
	Right	Thru	Left	U-Turn	App Total	Peds CW	Peds CCW	Right	Thru	Left	U-Turn	App Total	Peds CW	Peds CCW	Right	Thru	Left	U-Turn	App Total	Peds CW		Peds CCW			
4:15:00 PM	8	24	22	0	54	0	0	0	12	3	0	15	0	0	0	0	0	0	0	0	0	0	0	92	
4:30:00 PM	7	26	17	0	50	0	0	0	17	4	0	21	0	0	0	0	0	0	0	0	0	0	0	85	
4:45:00 PM	7	20	20	0	47	0	2	0	17	2	0	19	0	0	0	0	0	0	0	0	0	0	0	85	
5:00:00 PM	5	22	12	0	39	0	0	0	22	2	0	24	1	0	0	0	0	0	0	0	0	0	0	85	
<b>Grand Total</b>	<b>27</b>	<b>92</b>	<b>71</b>	<b>0</b>	<b>190</b>	<b>0</b>	<b>2</b>	<b>0</b>	<b>68</b>	<b>11</b>	<b>0</b>	<b>79</b>	<b>1</b>	<b>0</b>	<b>0</b>	<b>0</b>	<b>0</b>	<b>0</b>	<b>0</b>	<b>0</b>	<b>0</b>	<b>0</b>	<b>0</b>	<b>354</b>	
% Approach	14.2%	48.4%	37.4%	0.0%	0.0%	0.0%	0.0%	14.2%	85.8%	0.0%	0.0%	0.0%	0.0%	0.0%	45.1%	41.7%	13.2%	0.0%	0.0%	0.0%	0.0%	0.0%	0.0%	0.0%	0.0%
% Total	7.6%	26.0%	20.1%	0.0%	53.7%	0.0%	0.0%	0.0%	19.2%	3.1%	0.0%	22.3%	0.0%	0.0%	0.0%	0.0%	0.0%	0.0%	0.0%	0.0%	0.0%	0.0%	0.0%	0.0%	0.0%
PHF	0.844	0.885	0.807	0.000	0.890	0.000	0.000	0.000	0.773	0.688	0.000	0.823	0.000	0.000	0.000	0.000	0.000	0.000	0.000	0.000	0.000	0.000	0.000	0.000	0.862
Lights	25	86	70	0	181	0	0	0	67	11	0	78	0	0	0	0	0	0	0	0	0	0	0	0	338
% Lights	92.6%	93.5%	98.6%	0.0%	95.3%	0.0%	0.0%	0.0%	98.5%	100.0%	0.0%	98.7%	0.0%	0.0%	0.0%	0.0%	0.0%	0.0%	0.0%	0.0%	0.0%	0.0%	0.0%	0.0%	95.5%
Trucks	0	0	0	0	0	0	0	0	0	0	0	0	0	0	0	0	0	0	0	0	0	0	0	0	0
% Trucks	0.0%	0.0%	0.0%	0.0%	0.0%	0.0%	0.0%	0.0%	0.0%	0.0%	0.0%	0.0%	0.0%	0.0%	0.0%	0.0%	0.0%	0.0%	0.0%	0.0%	0.0%	0.0%	0.0%	0.0%	0.0%
Buses	2	6	1	0	9	0	0	0	1	0	0	1	0	0	0	0	0	0	0	0	0	0	0	0	16
% Buses	7.4%	6.5%	1.4%	0.0%	0.0%	0.0%	0.0%	0.0%	1.5%	0.0%	0.0%	0.0%	0.0%	0.0%	0.0%	0.0%	0.0%	0.0%	0.0%	0.0%	0.0%	0.0%	0.0%	0.0%	4.8%
Pedestrians	0	0	0	0	0	0	2	0	0	0	0	1	1	0	0	0	0	0	0	0	2	0	0	1	1
% Pedestrians	0.0%	0.0%	0.0%	0.0%	0.0%	0.0%	100.0%	0.0%	0.0%	0.0%	0.0%	0.0%	100.0%	100.0%	0.0%	0.0%	0.0%	0.0%	0.0%	0.0%	0.0%	0.0%	0.0%	100.0%	100.0%
Bicycles on Crosswalk	0	0	0	0	0	0	0	0	0	0	0	0	0	0	0	0	0	0	0	0	0	0	0	0	0
% Bicycles on Crosswalk	0.0%	0.0%	0.0%	0.0%	0.0%	0.0%	0.0%	0.0%	0.0%	0.0%	0.0%	0.0%	0.0%	0.0%	0.0%	0.0%	0.0%	0.0%	0.0%	0.0%	0.0%	0.0%	0.0%	0.0%	0.0%

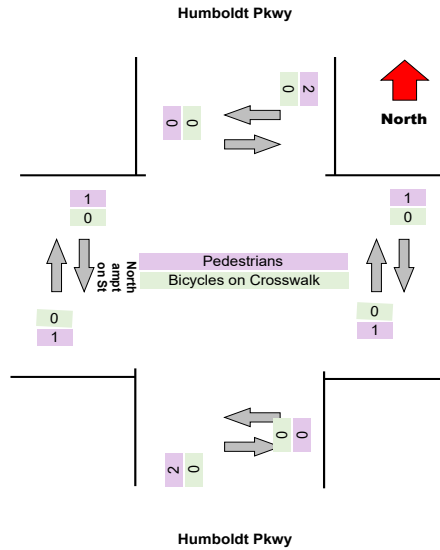
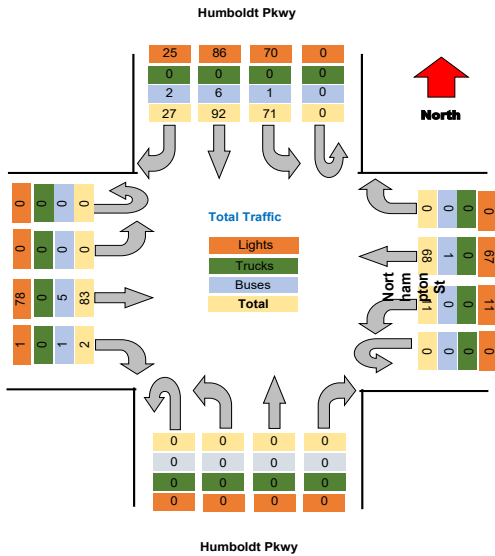



Project : VBH Malta NY  
 Site : Site 4  
 Location : 42.948550, -73.790036  
 Survey Date : 2021-04-28, Wednesday

### Turning Movement Data Plot

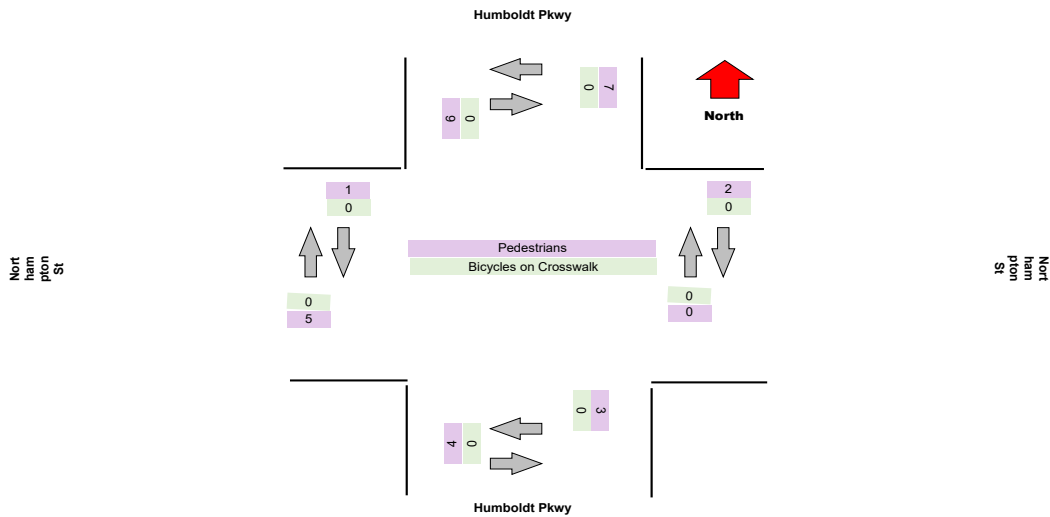
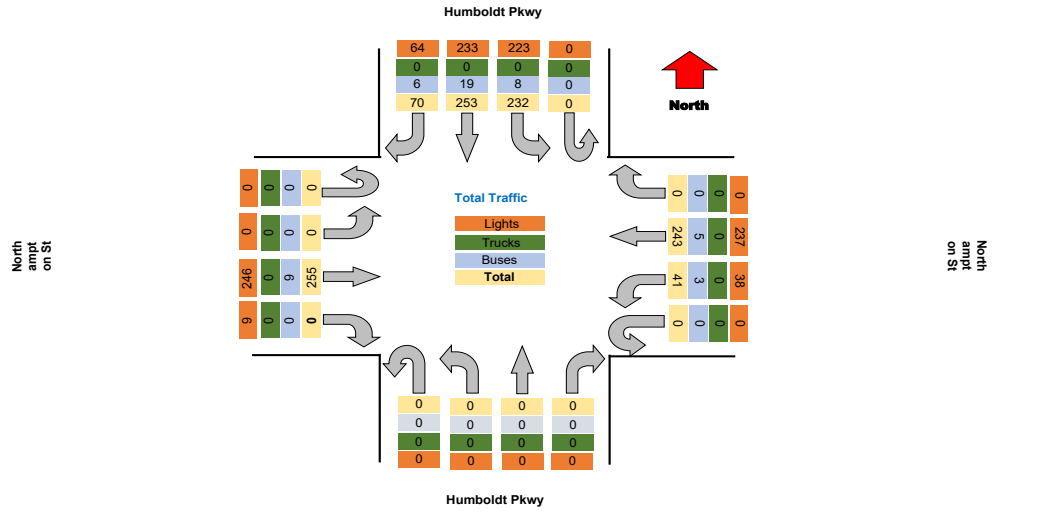

Project : VBH Malta NY  
Site : Site 4  
Location : 42.948550, -73.790036

TSTData.com

Survey Date : 2021-04-28, Wednesday

**Turning Movement Peak Hour Data (AM)**

7:30:00 AM

Leg Direction	Humboldt Pkwy						Northampton St						Humboldt Pkwy						Northampton St						Total						
	Southbound			Westbound			Northbound			Eastbound			Southbound			Westbound			Northbound			Eastbound									
Start Time	Right	Thru	Left	U-Turn	App Total	Peds CW	Peds CCW	Right	Thru	Left	U-Turn	App Total	Peds CW	Peds CCW	Right	Thru	Left	U-Turn	App Total	Peds CW	Peds CCW	Right	Thru	Left	U-Turn	App Total	Peds CW	Peds CCW			
7:30:00 AM	1	4	8	0	13	2	0	0	12	0	0	12	0	0	0	0	0	0	0	0	0	0	0	0	0	6	0	0	31		
7:45:00 AM	6	20	16	0	42	0	0	0	15	2	0	17	0	0	0	0	0	0	0	0	0	0	0	0	0	18	0	0	77		
8:00:00 AM	8	16	14	0	38	0	0	0	16	2	0	18	0	0	0	0	0	0	0	0	0	0	0	0	1	14	0	0	71		
8:15:00 AM	5	12	22	0	39	0	0	0	7	1	0	8	0	0	0	0	0	0	0	0	0	0	0	0	0	15	0	0	63		
<b>Grand Total</b>	<b>20</b>	<b>52</b>	<b>60</b>	<b>0</b>	<b>132</b>	<b>2</b>	<b>0</b>	<b>0</b>	<b>50</b>	<b>5</b>	<b>0</b>	<b>55</b>	<b>0</b>	<b>0</b>	<b>0</b>	<b>0</b>	<b>0</b>	<b>0</b>	<b>0</b>	<b>0</b>	<b>0</b>	<b>0</b>	<b>0</b>	<b>0</b>	<b>1</b>	<b>53</b>	<b>0</b>	<b>0</b>	<b>242</b>		
% Approach	15.2%	39.4%	45.5%	0.0%	0.0%	0.0%	0.0%	14.2%	85.8%	0.0%	0.0%	0.0%	0.0%	0.0%	45.1%	41.7%	13.2%	0.0%	0.0%	0.0%	0.0%	0.0%	0.0%	0.0%	0.0%	0.0%	66.2%	33.8%	0.0%	0.0%	0.0%
% Total	8.3%	21.5%	24.8%	0.0%	54.5%	0.0%	0.0%	0.0%	20.7%	2.1%	0.0%	23.1%	0.0%	0.0%	0.0%	0.0%	0.0%	0.0%	0.0%	0.0%	0.0%	0.0%	0.0%	0.0%	0.4%	21.9%	0.0%	0.0%	22.3%	0.0%	0.0%
PHF	0.625	0.650	0.682	0.000	0.786	0.000	0.000	0.000	0.781	0.625	0.000	0.778	0.000	0.000	0.000	0.000	0.000	0.000	0.000	0.000	0.000	0.000	0.000	0.000	0.250	0.736	0.000	0.000	0.750	0.000	0.000
Lights	19	48	56	0	123	0	0	0	49	4	0	53	0	0	0	0	0	0	0	0	0	0	0	0	1	50	0	0	51	0	0
% Lights	85.0%	92.3%	93.3%	0.0%	93.2%	0.0%	0.0%	0.0%	98.0%	80.0%	0.0%	94.6%	0.0%	0.0%	0.0%	0.0%	0.0%	0.0%	0.0%	0.0%	0.0%	0.0%	0.0%	0.0%	100.0%	94.3%	0.0%	0.0%	94.4%	0.0%	0.0%
Trucks	0	0	0	0	0	0	0	0	0	0	0	0	0	0	0	0	0	0	0	0	0	0	0	0	0	0	0	0	0	0	0
% Trucks	0.0%	0.0%	0.0%	0.0%	0.0%	0.0%	0.0%	0.0%	0.0%	0.0%	0.0%	0.0%	0.0%	0.0%	0.0%	0.0%	0.0%	0.0%	0.0%	0.0%	0.0%	0.0%	0.0%	0.0%	0.0%	0.0%	0.0%	0.0%	0.0%	0.0%	0.0%
Buses	1	4	4	0	9	0	0	0	1	1	0	2	0	0	0	0	0	0	0	0	0	0	0	0	0	3	0	0	3	0	0
% Buses	5.0%	7.7%	6.7%	0.0%	6.8%	0.0%	0.0%	0.0%	2.0%	20.0%	0.0%	3.6%	0.0%	0.0%	0.0%	0.0%	0.0%	0.0%	0.0%	0.0%	0.0%	0.0%	0.0%	0.0%	0.0%	5.7%	0.0%	0.0%	6.0%	0.0%	0.0%
Pedestrians	0	0	0	0	0	2	1	0	0	0	0	0	0	0	0	0	0	0	0	0	0	0	0	0	0	0	0	0	2	0	0
% Pedestrians	0.0%	0.0%	0.0%	0.0%	0.0%	100.0%	100.0%	0.0%	0.0%	0.0%	0.0%	0.0%	0.0%	0.0%	0.0%	0.0%	0.0%	0.0%	0.0%	0.0%	0.0%	0.0%	0.0%	0.0%	0.0%	0.0%	0.0%	0.0%	100.0%	0.0%	0.0%
Bicycles on Crosswalk	0	0	0	0	0	0	0	0	0	0	0	0	0	0	0	0	0	0	0	0	0	0	0	0	0	0	0	0	0	0	0
% Bicycles on Crosswalk	0.0%	0.0%	0.0%	0.0%	0.0%	0.0%	0.0%	0.0%	0.0%	0.0%	0.0%	0.0%	0.0%	0.0%	0.0%	0.0%	0.0%	0.0%	0.0%	0.0%	0.0%	0.0%	0.0%	0.0%	0.0%	0.0%	0.0%	0.0%	0.0%	0.0%	0.0%

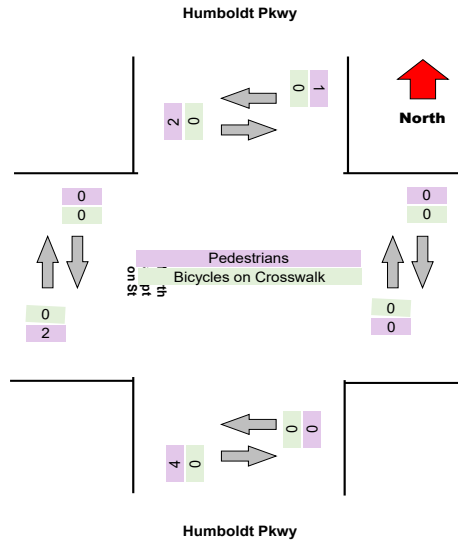
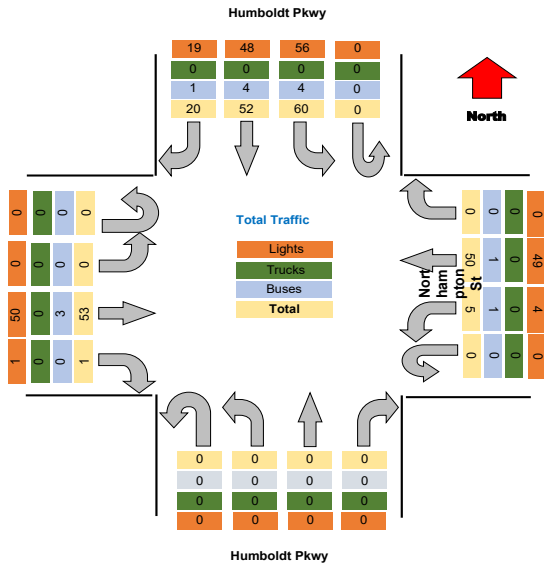

Project : VBH Malta NY  
Site : Site 4  
Location : 42.948550, -73.790036

TSTData.com

Survey Date : 2021-04-28, Wednesday

### Turning Movement Peak Hour Data (PM)

4:15:00 PM

Leg Direction	Humboldt Pkwy										Northampton St										Total
	Southbound					Westbound					Northbound					Eastbound					
	Right	Thru	Left	U-Turn	App Total	Right	Thru	Left	U-Turn	App Total	Right	Thru	Left	U-Turn	App Total	Right	Thru	Left	U-Turn	App Total	
4:15:00 PM	5	22	24	0	51	0	15	3	0	18	0	0	0	0	0	0	27	0	0	27	96
4:30:00 PM	6	25	20	0	51	0	23	3	0	26	0	0	0	0	0	1	26	0	0	27	104
4:45:00 PM	5	27	9	0	41	0	22	5	0	27	0	0	0	0	0	3	22	0	0	25	93
5:00:00 PM	5	12	24	0	41	0	22	3	0	25	0	0	0	0	0	0	28	0	0	28	94
<b>Grand Total</b>	21	86	77	0	154	0	82	14	0	96	0	0	0	0	0	4	103	0	0	107	387
% Approach	11.4%	46.7%	41.8%	0.0%	0.0%	14.2%	85.8%	0.0%	0.0%	0.0%	45.1%	41.7%	13.2%	0.0%	0.0%	0.0%	66.2%	33.8%	0.0%	0.0%	0.0%
% Total	5.4%	22.2%	19.9%	0.0%	47.5%	0.0%	21.2%	3.6%	0.0%	24.8%	0.0%	0.0%	0.0%	0.0%	0.0%	1.0%	26.6%	0.0%	0.0%	27.6%	0.0%
PHF	0.875	0.796	0.802	0.000	0.902	0.000	0.891	0.700	0.000	0.889	0.000	0.000	0.000	0.000	0.000	0.333	0.920	0.000	0.000	0.955	0.930
Lights	19	77	77	0	173	0	81	14	0	95	0	0	0	0	0	4	98	0	0	102	370
% Lights	80.5%	89.5%	100.0%	0.0%	94.0%	0.0%	98.8%	100.0%	0.0%	99.0%	0.0%	0.0%	0.0%	0.0%	0.0%	100.0%	95.1%	0.0%	0.0%	95.3%	95.6%
Trucks	0	0	0	0	0	0	0	0	0	0	0	0	0	0	0	0	0	0	0	0	0
% Trucks	0.0%	0.0%	0.0%	0.0%	0.0%	0.0%	0.0%	0.0%	0.0%	0.0%	0.0%	0.0%	0.0%	0.0%	0.0%	0.0%	0.0%	0.0%	0.0%	0.0%	0.0%
Buses	2	8	0	0	10	0	1	0	0	1	0	0	0	0	0	0	5	0	0	5	16
% Buses	9.5%	9.3%	0.0%	0.0%	6.5%	0.0%	1.2%	0.0%	0.0%	1.0%	0.0%	0.0%	0.0%	0.0%	0.0%	0.0%	4.9%	0.0%	0.0%	4.7%	4.1%
Pedestrians	0	0	0	0	0	0	0	0	0	0	0	0	0	0	0	0	0	0	0	0	0
% Pedestrians	0.0%	0.0%	0.0%	0.0%	0.0%	0.0%	0.0%	0.0%	0.0%	0.0%	0.0%	0.0%	0.0%	0.0%	0.0%	0.0%	0.0%	0.0%	0.0%	0.0%	0.0%
Bicycles on Crosswalk	0	0	0	0	0	0	0	0	0	0	0	0	0	0	0	0	0	0	0	0	0
% Bicycles on Crosswalk	0.0%	0.0%	0.0%	0.0%	0.0%	0.0%	0.0%	0.0%	0.0%	0.0%	0.0%	0.0%	0.0%	0.0%	0.0%	0.0%	0.0%	0.0%	0.0%	0.0%	0.0%

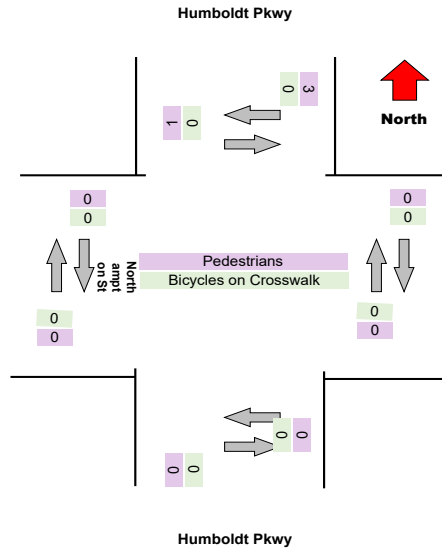
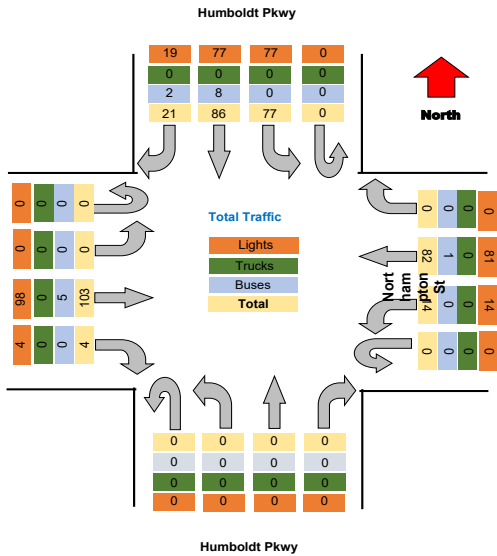



Project : VBH Malta NY  
 Site : Site 4  
 Location : 42.948550, -73.790036  
 Survey Date : 2021-04-28, Wednesday

### Turning Movement Data Plot

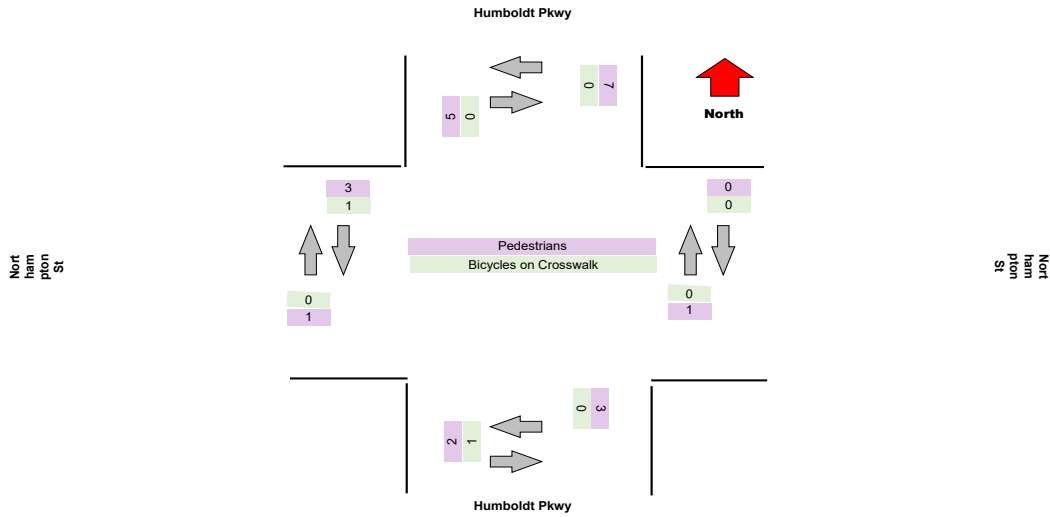
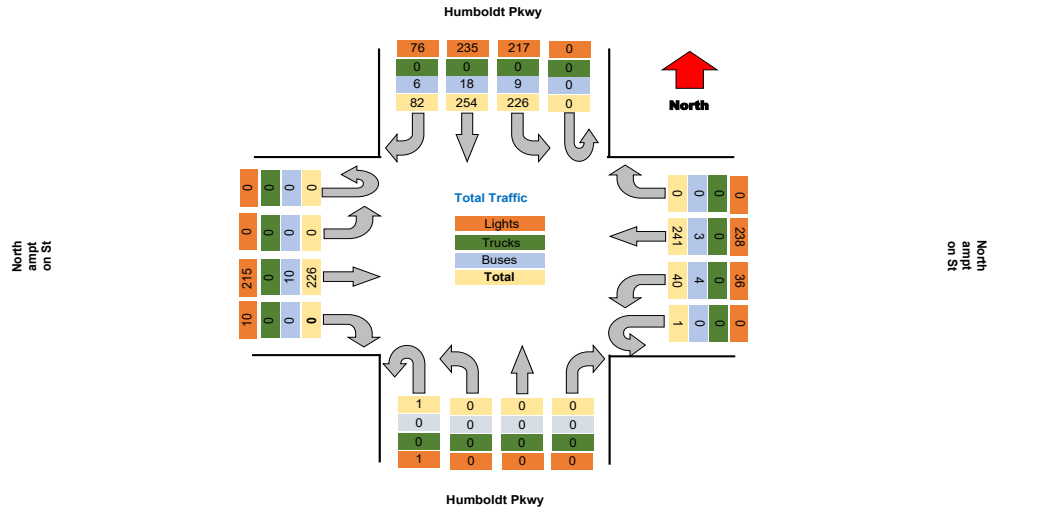

Project : VBH Malta NY  
Site : Site 4  
Location : 42.948550, -73.790036

TSTData.com

Survey Date : 2021-04-28, Wednesday

**Turning Movement Peak Hour Data (AM)**

7:30:00 AM

Leg Direction	Humboldt Pkwy						Northampton St						Humboldt Pkwy						Northampton St						Total					
	Southbound			Westbound			Northbound			Eastbound			Southbound			Westbound			Northbound			Eastbound								
Start Time	Right	Thru	Left	U-Turn	App Total	Peds CW	Peds CCW	Right	Thru	Left	U-Turn	App Total	Peds CW	Peds CCW	Right	Thru	Left	U-Turn	App Total	Peds CW	Peds CCW	Right	Thru	Left	U-Turn	App Total	Peds CW	Peds CCW		
7:30:00 AM	2	8	10	0	20	2	1	0	11	1	0	13	0	0	0	0	0	0	0	1	0	0	0	0	0	6	0	0	39	
7:45:00 AM	7	19	28	0	54	0	0	0	14	2	0	16	0	0	0	0	0	0	0	0	0	0	0	1	0	20	0	0	90	
8:00:00 AM	3	14	19	0	36	0	0	0	14	1	0	15	0	0	0	0	0	0	0	0	0	0	0	0	1	11	0	0	63	
8:15:00 AM	13	15	14	0	42	0	0	0	8	3	0	11	0	0	0	0	0	0	0	0	0	0	0	0	0	12	0	0	66	
<b>Grand Total</b>	<b>25</b>	<b>59</b>	<b>71</b>	<b>0</b>	<b>152</b>	<b>2</b>	<b>1</b>	<b>0</b>	<b>47</b>	<b>7</b>	<b>0</b>	<b>55</b>	<b>0</b>	<b>0</b>	<b>0</b>	<b>0</b>	<b>0</b>	<b>0</b>	<b>1</b>	<b>1</b>	<b>1</b>	<b>1</b>	<b>49</b>	<b>0</b>	<b>0</b>	<b>59</b>	<b>3</b>	<b>0</b>	<b>257</b>	
% Approach	16.4%	36.8%	46.7%	0.0%	0.0%	0.0%	0.0%	14.2%	85.8%	0.0%	0.0%	0.0%	0.0%	0.0%	45.1%	41.7%	13.2%	0.0%	0.0%	0.0%	0.0%	0.0%	0.0%	0.0%	0.0%	66.2%	33.8%	0.0%	0.0%	0.0%
% Total	9.7%	21.8%	27.6%	0.0%	58.1%	0.0%	0.0%	0.0%	18.3%	2.7%	0.0%	21.4%	0.0%	0.0%	0.0%	0.0%	0.0%	0.0%	0.0%	0.0%	0.0%	0.0%	0.0%	0.0%	0.4%	19.1%	0.0%	0.0%	19.5%	0.0%
PHF	0.481	0.737	0.634	0.000	0.704	0.000	0.000	0.000	0.839	0.583	0.000	0.859	0.000	0.000	0.000	0.000	0.000	0.000	0.000	0.000	0.000	0.000	0.000	0.000	0.250	0.613	0.000	0.000	0.625	0.000
Lights	24	51	66	0	141	0	0	0	46	6	0	52	0	0	0	0	0	0	0	0	0	0	0	0	1	45	0	0	239	
% Lights	96.0%	91.1%	93.0%	0.0%	92.8%	0.0%	0.0%	0.0%	97.9%	85.7%	0.0%	94.5%	0.0%	0.0%	0.0%	0.0%	0.0%	0.0%	0.0%	0.0%	0.0%	0.0%	0.0%	0.0%	100.0%	91.8%	0.0%	0.0%	92.0%	0.0%
Trucks	0	0	0	0	0	0	0	0	0	0	0	0	0	0	0	0	0	0	0	0	0	0	0	0	0	0	0	0	0	0
% Trucks	0.0%	0.0%	0.0%	0.0%	0.0%	0.0%	0.0%	0.0%	0.0%	0.0%	0.0%	0.0%	0.0%	0.0%	0.0%	0.0%	0.0%	0.0%	0.0%	0.0%	0.0%	0.0%	0.0%	0.0%	0.0%	0.0%	0.0%	0.0%	0.0%	0.0%
Buses	1	5	5	0	11	0	0	0	1	1	0	2	0	0	0	0	0	0	0	0	0	0	0	0	0	4	0	0	4	17
% Buses	4.0%	8.9%	7.0%	0.0%	0.0%	0.0%	0.0%	0.0%	2.1%	14.3%	0.0%	0.0%	0.0%	0.0%	0.0%	0.0%	0.0%	0.0%	0.0%	0.0%	0.0%	0.0%	0.0%	0.0%	0.0%	8.2%	0.0%	0.0%	0.0%	6.8%
Pedestrians	0	0	0	0	0	2	1	0	0	0	0	0	0	0	0	0	0	0	0	1	1	0	0	0	0	0	0	0	0	0
% Pedestrians	0.0%	0.0%	0.0%	0.0%	0.0%	100.0%	100.0%	0.0%	0.0%	0.0%	0.0%	0.0%	0.0%	0.0%	0.0%	0.0%	0.0%	0.0%	0.0%	0.0%	100.0%	100.0%	0.0%	0.0%	0.0%	0.0%	0.0%	0.0%	0.0%	0.0%
Bicycles on Crosswalk	0	0	0	0	0	0	0	0	0	0	0	0	0	0	0	0	0	0	0	0	0	0	0	0	0	0	0	0	0	0
% Bicycles on Crosswalk	0.0%	0.0%	0.0%	0.0%	0.0%	0.0%	0.0%	0.0%	0.0%	0.0%	0.0%	0.0%	0.0%	0.0%	0.0%	0.0%	0.0%	0.0%	0.0%	0.0%	0.0%	0.0%	0.0%	0.0%	0.0%	0.0%	0.0%	0.0%	0.0%	0.0%

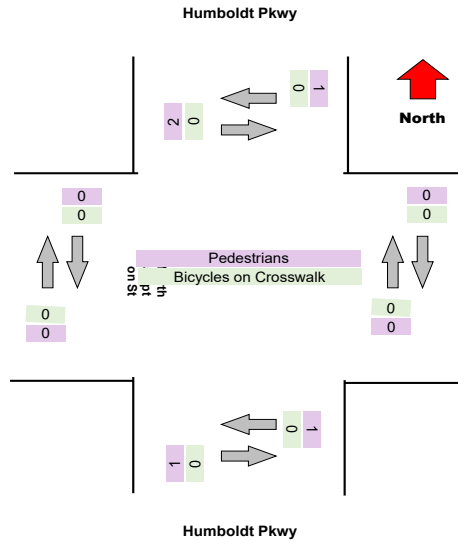
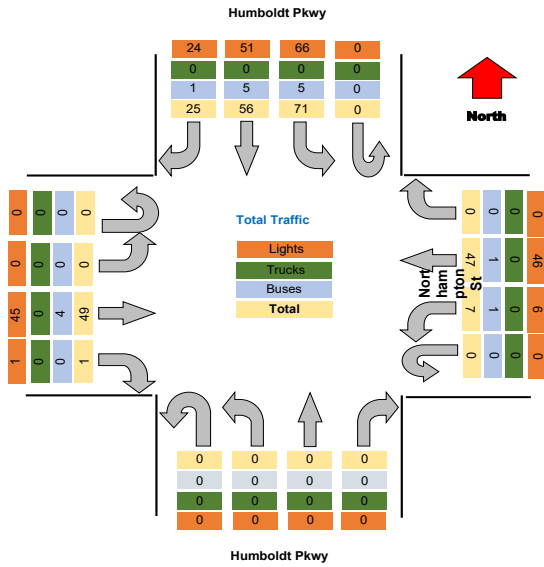



### Turning Movement Peak Hour Data (PM)

4:15:00 PM

Leg Direction	Humboldt Pkwy										Northampton St										Total	
	Southbound					Westbound					Northbound					Eastbound						
	Right	Thru	Left	U-Turn	App Total	Right	Thru	Left	U-Turn	App Total	Right	Thru	Left	U-Turn	App Total	Right	Thru	Left	U-Turn	App Total		
4:15:00 PM	9	22	19	0	50	0	22	5	1	28	0	0	0	0	0	0	31	0	0	31	109	
4:30:00 PM	7	29	12	0	48	0	23	3	0	26	0	0	0	0	0	1	25	0	0	26	100	
4:45:00 PM	4	13	16	0	33	0	20	5	0	25	0	1	0	0	1	2	6	0	0	8	66	
5:00:00 PM	10	19	20	0	49	0	14	3	0	17	0	0	0	0	0	1	24	0	0	25	91	
<b>Grand Total</b>	<b>30</b>	<b>83</b>	<b>57</b>	<b>0</b>	<b>180</b>	<b>0</b>	<b>79</b>	<b>15</b>	<b>1</b>	<b>95</b>	<b>0</b>	<b>0</b>	<b>0</b>	<b>0</b>	<b>0</b>	<b>4</b>	<b>86</b>	<b>0</b>	<b>0</b>	<b>90</b>	<b>368</b>	
% Approach	16.7%	46.1%	37.2%	0.0%	0.0%	14.2%	85.8%	0.0%	0.0%	0.0%	45.1%	41.7%	13.2%	0.0%	0.0%	0.0%	66.2%	33.8%	0.0%	0.0%	0.0%	0.0%
% Total	8.2%	22.7%	18.3%	0.0%	49.2%	0.0%	21.6%	4.4%	0.3%	26.2%	0.0%	0.0%	0.0%	0.0%	0.0%	1.1%	23.5%	0.0%	0.0%	24.6%	0.0%	0.0%
PHF	0.750	0.716	0.838	0.000	0.900	0.000	0.859	0.800	0.250	0.857	0.000	0.000	0.000	0.000	0.000	0.500	0.694	0.000	0.000	0.726	0.000	0.000
Lights	27	76	67	0	170	0	78	15	0	93	0	0	0	0	0	4	81	0	0	85	348	
% Lights	80.0%	91.6%	100.0%	0.0%	94.4%	0.0%	98.7%	93.8%	0.0%	96.8%	0.0%	0.0%	0.0%	0.0%	0.0%	100.0%	94.2%	0.0%	0.0%	94.4%	0.0%	0.0%
Trucks	0	0	0	0	0	0	0	0	0	0	0	0	0	0	0	0	0	0	0	0	0	0
% Trucks	0.0%	0.0%	0.0%	0.0%	0.0%	0.0%	0.0%	0.0%	0.0%	0.0%	0.0%	0.0%	0.0%	0.0%	0.0%	0.0%	0.0%	0.0%	0.0%	0.0%	0.0%	0.0%
Buses	3	6	0	0	9	0	1	1	0	2	0	0	0	0	0	0	4	0	0	4	15	
% Buses	10.0%	7.2%	0.0%	0.0%	0.0%	0.0%	1.3%	6.3%	0.0%	0.0%	0.0%	0.0%	0.0%	0.0%	0.0%	0.0%	4.7%	0.0%	0.0%	0.0%	0.0%	0.0%
Pedestrians	0	0	0	0	0	0	0	0	0	0	0	1	0	0	1	0	0	0	0	0	1	1
% Pedestrians	0.0%	0.0%	0.0%	0.0%	0.0%	0.0%	0.0%	0.0%	0.0%	0.0%	0.0%	0.0%	0.0%	0.0%	100.0%	0.0%	0.0%	0.0%	0.0%	0.0%	100.0%	50.0%
Bicycles on Crosswalk	0	0	0	0	0	0	0	0	0	0	0	0	0	0	0	0	0	0	0	0	0	1
% Bicycles on Crosswalk	0.0%	0.0%	0.0%	0.0%	0.0%	0.0%	0.0%	0.0%	0.0%	0.0%	0.0%	0.0%	0.0%	0.0%	0.0%	0.0%	0.0%	0.0%	0.0%	0.0%	0.0%	50.0%

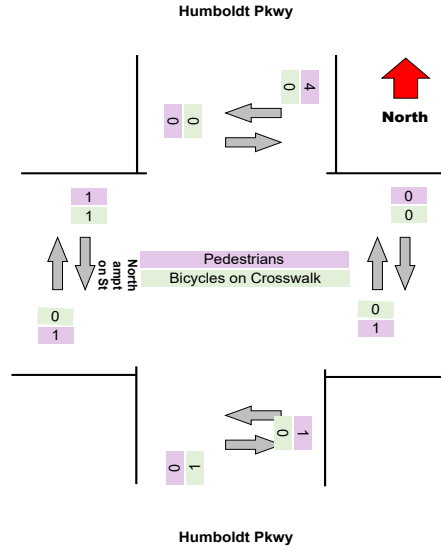
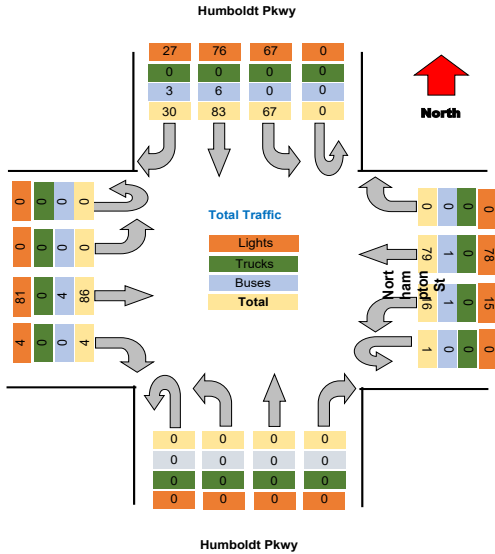

Survey Date : 2021-04-28, Wednesday

Project	Labella
Project Code	Labella
Site Name	5
Legs and Movements	All Processed Legs & Move
Bin Size	15 minutes
Survey Date	2021-10-26, Tuesday
Location	5
Latitude and Longitude	42.907349, -78.843174

	Start	End	PHF
Forced Peak AM	2021/10/26 07:30:00	2021/10/26 08:30:00	0.89
Forced Peak PM	2021/10/26 16:30:00	2021/10/26 17:30:00	0.9
AM Peak	2021/10/26 07:30:00	2021/10/26 08:30:00	0.89
PM Peak	2021/10/26 16:15:00	2021/10/26 17:15:00	0.88

### Turning Movement Data

Leg Direction	Humboldt Pkwy							Northampton St							Martin Luther King Park							Northampton St							Total
	Southbound				Westbound			Northbound				Eastbound			Eastbound				Eastbound										
	Right	Thru	Left	U-Turn	App Total	Peds CV	Peds CCV	Right	Thru	Left	U-Turn	App Total	Peds CV	Peds CCV	Right	Thru	Left	U-Turn	App Total	Peds CV	Peds CCV	Right	Thru	Left	U-Turn	App Total	Peds CV	Peds CCV	
Start Time	0	0	0	0	0	0	0	0	2	0	0	2	1	0	0	0	1	0	2	0	0	0	4	2	0	6	0	0	
6:30:00 AM	0	0	0	0	0	0	0	0	14	0	0	14	0	0	0	0	1	0	2	0	0	0	7	4	0	11	0	0	
6:45:00 AM	0	0	0	0	0	0	0	0	16	0	0	16	1	0	0	0	0	0	4	0	0	0	11	6	0	17	0	0	
Hourly Total	0	0	0	0	0	1	0	3	11	1	0	15	1	0	0	0	0	0	0	0	0	0	6	3	0	9	0	0	
7:00:00 AM	0	0	0	0	0	0	0	3	19	0	0	22	0	0	0	3	0	0	3	0	0	0	11	1	0	12	0	0	
7:15:00 AM	0	0	0	0	0	0	0	2	15	0	0	17	0	0	0	5	0	0	5	0	0	0	13	8	0	21	0	0	
7:30:00 AM	0	0	0	0	0	0	0	4	29	0	0	33	0	0	2	3	2	0	7	0	0	0	16	4	0	20	0	0	
7:45:00 AM	0	0	0	0	0	0	0	12	74	1	0	87	0	0	2	11	2	0	15	0	0	0	46	16	0	62	0	0	
Hourly Total	0	0	0	0	0	2	0	5	23	0	0	28	0	0	3	5	2	0	10	0	0	0	14	7	0	21	0	0	
8:00:00 AM	0	0	0	0	0	0	0	5	14	0	0	19	0	0	3	4	1	0	8	0	0	0	20	4	0	24	0	0	
8:15:00 AM	0	0	0	0	0	0	0	10	37	0	0	47	0	0	6	9	3	0	18	0	0	0	34	11	0	45	0	0	
Hourly Total	0	0	0	0	0	0	0	4	18	0	0	22	0	0	2	4	0	0	6	0	0	0	34	11	0	45	0	0	
4:00:00 PM	0	0	0	0	0	0	0	9	16	0	0	25	0	0	4	7	0	0	11	0	0	0	33	12	0	45	0	0	
4:15:00 PM	0	0	0	0	0	0	0	8	22	0	0	30	0	0	0	6	0	0	6	0	0	0	28	9	0	37	0	0	
4:30:00 PM	0	0	0	0	0	0	0	3	20	0	0	23	1	1	0	5	0	0	5	0	0	0	26	14	0	40	0	0	
4:45:00 PM	0	0	0	0	0	0	0	24	78	0	0	100	1	1	6	22	0	0	28	0	0	0	121	46	0	167	0	0	
Hourly Total	0	0	0	0	0	1	24	4	24	0	0	28	2	0	1	1	1	0	3	0	1	0	19	13	0	32	0	0	
5:00:00 PM	0	0	0	0	0	0	0	2	17	0	0	19	0	2	1	8	1	0	10	0	0	0	23	8	0	31	0	0	
5:15:00 PM	0	0	0	0	0	0	0	4	19	0	0	23	0	0	2	2	0	0	4	0	0	1	19	7	0	27	0	0	
5:30:00 PM	0	0	0	0	0	0	0	5	19	0	0	24	0	0	1	2	0	0	3	0	0	0	15	10	0	25	0	0	
5:45:00 PM	0	0	0	0	0	0	0	15	79	0	0	94	2	2	5	13	2	0	20	0	1	1	76	38	0	115	0	0	
Hourly Total	0	0	0	0	0	3	1	61	282	1	0	344	4	3	19	56	9	0	85	0	1	1	288	117	0	408	0	0	
Grand Total	0	0	0	0	0	3	1	61	282	1	0	344	4	3	19	56	9	0	85	0	1	1	288	117	0	408	0	0	
% Approach	0.0%	0.0%	0.0%	0.0%	0.0%	0.0%	0.0%	17.7%	82.0%	0.3%	0.0%	0.0%	0.0%	0.0%	22.4%	65.9%	10.6%	0.0%	0.0%	0.0%	0.0%	0.2%	70.9%	28.8%	0.0%	0.0%	0.0%	0.0%	
% Total	0.0%	0.0%	0.0%	0.0%	0.0%	0.0%	0.0%	7.3%	33.8%	0.1%	0.0%	41.2%	0.0%	0.0%	2.3%	6.7%	1.1%	0.0%	10.2%	0.0%	0.0%	0.1%	34.5%	14.0%	0.0%	48.6%	0.0%	0.0%	
Lights	0	0	0	0	0	0	0	45	269	1	0	315	0	0	19	52	9	0	80	0	0	1	280	111	0	392	0	0	
% Lights	0.0%	0.0%	0.0%	0.0%	0.0%	0.0%	0.0%	73.9%	95.4%	100.0%	0.0%	91.6%	0.0%	0.0%	100.0%	92.9%	100.0%	0.0%	94.1%	0.0%	0.0%	100.0%	97.2%	94.9%	0.0%	96.6%	0.0%	0.0%	
Trucks	0	0	0	0	0	0	0	0	0	0	0	0	0	0	0	0	0	0	0	0	0	0	0	0	0	0	0	0	
% Trucks	0.0%	0.0%	0.0%	0.0%	0.0%	0.0%	0.0%	0.0%	0.0%	0.0%	0.0%	0.0%	0.0%	0.0%	0.0%	0.0%	0.0%	0.0%	0.0%	0.0%	0.0%	0.0%	0.0%	0.0%	0.0%	0.0%	0.0%	0.0%	
Buses	0	0	0	0	0	0	0	16	13	0	0	29	0	0	0	4	0	0	4	0	0	0	8	6	0	14	0	0	
% Buses	0.0%	0.0%	0.0%	0.0%	0.0%	0.0%	0.0%	0.0%	4.6%	0.0%	0.0%	0.0%	0.0%	0.0%	0.0%	7.1%	0.0%	0.0%	0.0%	0.0%	0.0%	0.0%	2.8%	5.1%	0.0%	0.0%	0.0%	0.0%	
Pedestrians	0	0	0	0	0	3	1	0	0	0	0	0	4	3	0	0	0	0	0	0	1	0	0	0	0	0	0	0	
% Pedestrians	0.0%	0.0%	0.0%	0.0%	0.0%	100.0%	100.0%	0.0%	0.0%	0.0%	0.0%	0.0%	100.0%	100.0%	0.0%	0.0%	0.0%	0.0%	0.0%	0.0%	100.0%	0.0%	0.0%	0.0%	0.0%	0.0%	0.0%	0.0%	
Bicycles on Crosswalk	0	0	0	0	0	0	0	0	0	0	0	0	0	0	0	0	0	0	0	0	0	0	0	0	0	0	0	0	
% Bicycles on Crosswalk	0.0%	0.0%	0.0%	0.0%	0.0%	0.0%	0.0%	0.0%	0.0%	0.0%	0.0%	0.0%	0.0%	0.0%	0.0%	0.0%	0.0%	0.0%	0.0%	0.0%	0.0%	0.0%	0.0%	0.0%	0.0%	0.0%	0.0%	0.0%	

Project : VBH Malta NY  
 Site : Site 4  
 Location : 42.948550, -73.790036  
 Survey Date : 2021-04-28, Wednesday

### Turning Movement Data Plot

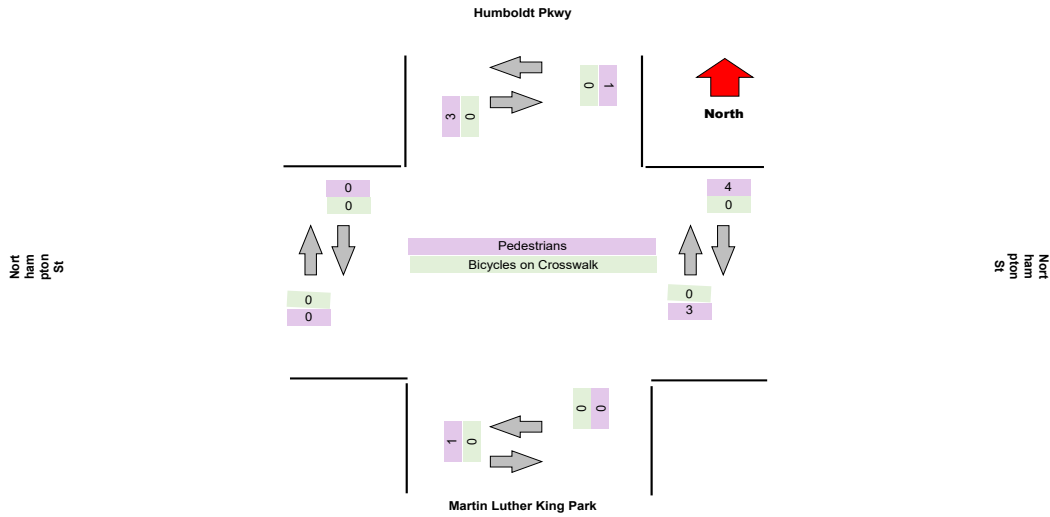
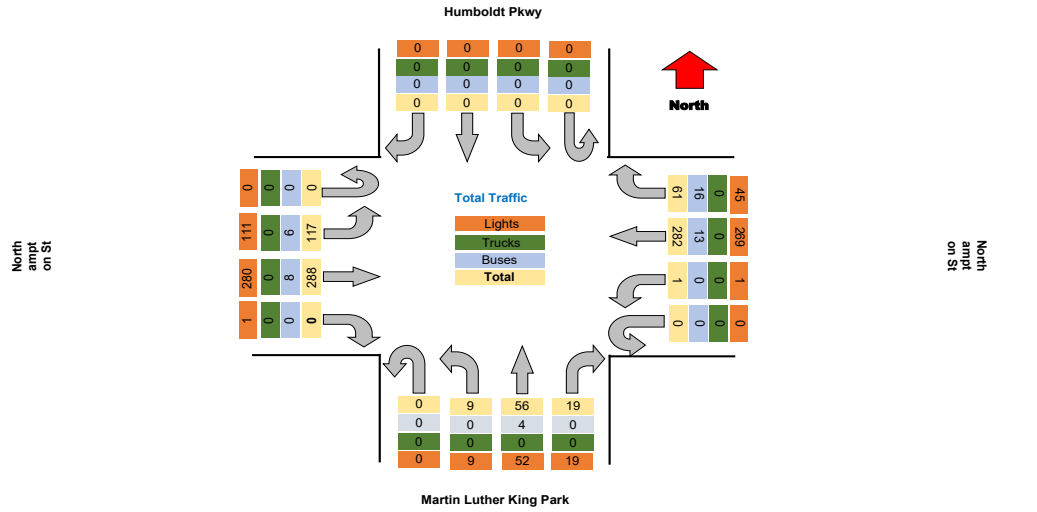

Project : VBH Malta NY  
Site : Site 4  
Location : 42.948550, -73.790036

TSTData.com

Survey Date : 2021-04-28, Wednesday

**Turning Movement Peak Hour Data (AM)**

7:30:00 AM

Leg Direction	Humboldt Pkwy				Northampton St				Martin Luther King Park				Northampton St				Total					
	Southbound		Northbound		Westbound		Eastbound		Northbound		Eastbound		Westbound									
Start Time	Right	Thru	Left	U-Turn	App Total	Peds CW	Peds CCW	Right	Thru	Left	U-Turn	App Total	Peds CW	Peds CCW	Right	Thru	Left	U-Turn	App Total	Peds CW	Peds CCW	
7:30:00 AM	0	0	0	0	0	2	0	2	15	0	0	17	0	0	0	5	0	0	5	0	0	0
7:45:00 AM	0	0	0	0	0	0	0	4	29	0	0	33	0	0	2	3	2	0	7	0	0	0
8:00:00 AM	0	0	0	0	0	0	0	5	23	0	0	28	0	0	3	5	2	0	10	0	0	0
8:15:00 AM	0	0	0	0	0	0	0	5	14	0	0	19	0	0	3	4	1	0	8	0	0	0
<b>Grand Total</b>	<b>0</b>	<b>0</b>	<b>0</b>	<b>0</b>	<b>0</b>	<b>2</b>	<b>0</b>	<b>16</b>	<b>81</b>	<b>0</b>	<b>0</b>	<b>87</b>	<b>0</b>	<b>0</b>	<b>8</b>	<b>17</b>	<b>5</b>	<b>0</b>	<b>30</b>	<b>0</b>	<b>0</b>	<b>0</b>
% Approach	#DIV/0!	#DIV/0!	#DIV/0!	#DIV/0!	0.0%	0.0%	0.0%	14.2%	85.8%	0.0%	0.0%	0.0%	0.0%	0.0%	45.1%	41.7%	13.2%	0.0%	0.0%	0.0%	0.0%	0.0%
% Total	0.0%	0.0%	0.0%	0.0%	0.0%	0.0%	0.0%	7.5%	38.0%	0.0%	0.0%	45.5%	0.0%	0.0%	3.8%	8.0%	2.3%	0.0%	14.1%	0.0%	0.0%	0.0%
PHF	0.000	0.000	0.000	0.000	0.000	0.000	0.000	0.800	0.698	0.000	0.000	0.735	0.000	0.000	0.667	0.850	0.625	0.000	0.750	0.000	0.000	0.000
Lights	0	0	0	0	0	0	0	10	72	0	0	82	0	0	8	16	5	0	29	0	0	0
% Lights	0.0%	0.0%	0.0%	0.0%	0.0%	0.0%	0.0%	62.5%	88.9%	0.0%	0.0%	84.5%	0.0%	0.0%	100.0%	94.1%	100.0%	0.0%	96.7%	0.0%	0.0%	0.0%
Trucks	0	0	0	0	0	0	0	0	0	0	0	0	0	0	0	0	0	0	0	0	0	0
% Trucks	0.0%	0.0%	0.0%	0.0%	0.0%	0.0%	0.0%	0.0%	0.0%	0.0%	0.0%	0.0%	0.0%	0.0%	0.0%	0.0%	0.0%	0.0%	0.0%	0.0%	0.0%	0.0%
Buses	0	0	0	0	0	0	0	6	9	0	0	15	0	0	0	1	0	0	1	0	0	0
% Buses	0.0%	0.0%	0.0%	0.0%	0.0%	0.0%	0.0%	37.5%	11.1%	0.0%	0.0%	8.5%	0.0%	0.0%	0.0%	5.9%	0.0%	0.0%	3.3%	0.0%	0.0%	0.0%
Pedestrians	0	0	0	0	0	2	0	0	0	0	0	0	0	0	0	0	0	0	0	0	0	0
% Pedestrians	0.0%	0.0%	0.0%	0.0%	0.0%	100.0%	0.0%	0.0%	0.0%	0.0%	0.0%	0.0%	0.0%	0.0%	0.0%	0.0%	0.0%	0.0%	0.0%	0.0%	0.0%	0.0%
Bicycles on Crosswalk	0	0	0	0	0	0	0	0	0	0	0	0	0	0	0	0	0	0	0	0	0	0
% Bicycles on Crosswalk	0.0%	0.0%	0.0%	0.0%	0.0%	0.0%	0.0%	0.0%	0.0%	0.0%	0.0%	0.0%	0.0%	0.0%	0.0%	0.0%	0.0%	0.0%	0.0%	0.0%	0.0%	0.0%

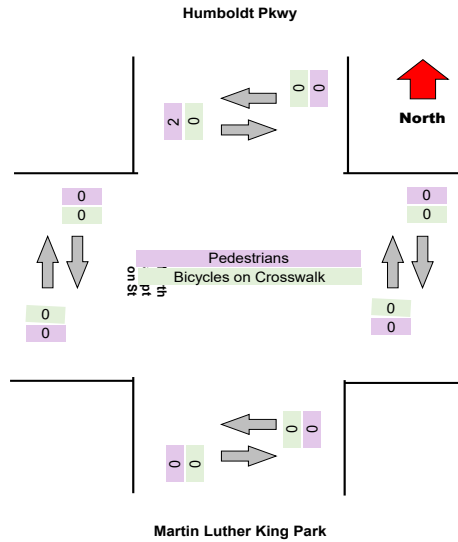
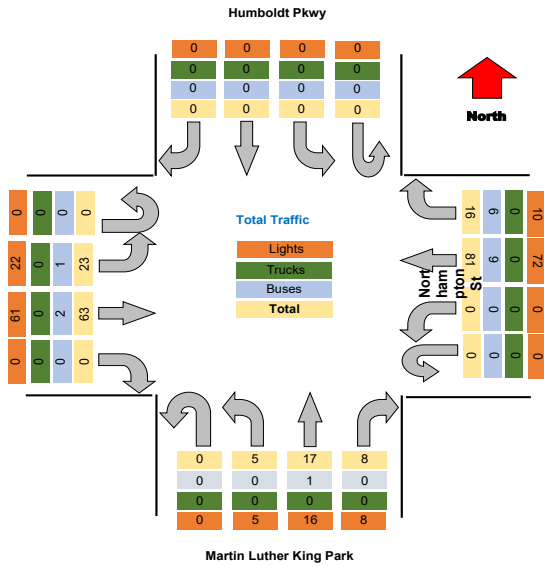

Project : VBH Malta NY  
Site : Site 4  
Location : 42.948550, -73.790036

TSTData.com

Survey Date : 2021-04-28, Wednesday

### Turning Movement Peak Hour Data (PM)

4:15:00 PM

Leg Direction	Humboldt Pkwy							Northampton St							Martin Luther King Park							Northampton St							Total
	Southbound			Westbound				Northbound			Eastbound				Northbound			Eastbound											
Start Time	Right	Thru	Left	U-Turn	App Total	Peds CW	Peds CCW	Right	Thru	Left	U-Turn	App Total	Peds CW	Peds CCW	Right	Thru	Left	U-Turn	App Total	Peds CW	Peds CCW	Right	Thru	Left	U-Turn	App Total	Peds CW	Peds CCW	
4:15:00 PM	0	0	0	0	0	0	0	9	16	0	0	25	0	0	4	7	0	0	11	0	0	0	33	12	0	45	0	0	81
4:30:00 PM	0	0	0	0	0	0	0	8	22	0	0	30	0	0	0	6	0	0	6	0	0	0	28	9	0	37	0	0	73
4:45:00 PM	0	0	0	0	0	0	0	3	20	0	0	23	1	1	0	5	0	0	5	0	0	0	26	14	0	40	0	0	68
5:00:00 PM	0	0	0	0	0	0	0	4	24	0	0	28	2	0	1	1	1	0	3	0	1	0	19	13	0	32	0	0	63
Grand Total	0	0	0	0	0	0	0	24	82	0	0	106	3	1	5	19	1	0	25	3	1	0	106	49	0	154	3	0	285
% Approach	#DIV/0!	#DIV/0!	#DIV/0!	#DIV/0!	0.0%	0.0%	0.0%	14.2%	85.8%	0.0%	0.0%	0.0%	0.0%	0.0%	45.1%	41.7%	13.2%	0.0%	0.0%	0.0%	0.0%	0.0%	66.2%	33.8%	0.0%	0.0%	0.0%	0.0%	
% Total	0.0%	0.0%	0.0%	0.0%	0.0%	0.0%	0.0%	8.4%	28.8%	0.0%	0.0%	37.2%	0.0%	0.0%	1.8%	6.7%	0.4%	0.0%	8.8%	0.0%	0.0%	0.0%	37.2%	16.8%	0.0%	54.0%	0.0%	0.0%	
PHF	0.000	0.000	0.000	0.000	0.000	0.000	0.000	0.667	0.854	0.000	0.000	0.883	0.000	0.000	0.313	0.679	0.250	0.000	0.568	0.000	0.000	0.000	0.803	0.857	0.000	0.856	0.000	0.000	0.880
Lights	0	0	0	0	0	0	0	17	81	0	0	98	0	0	5	16	1	0	22	0	0	0	102	46	0	148	0	0	268
% Lights	0.0%	0.0%	0.0%	0.0%	0.0%	0.0%	0.0%	70.8%	98.8%	0.0%	0.0%	92.5%	0.0%	0.0%	100.0%	84.2%	100.0%	0.0%	88.0%	0.0%	0.0%	0.0%	96.2%	95.8%	0.0%	96.1%	0.0%	0.0%	94.0%
Trucks	0	0	0	0	0	0	0	0	0	0	0	0	0	0	0	0	0	0	0	0	0	0	0	0	0	0	0	0	0
% Trucks	0.0%	0.0%	0.0%	0.0%	0.0%	0.0%	0.0%	0.0%	0.0%	0.0%	0.0%	0.0%	0.0%	0.0%	0.0%	0.0%	0.0%	0.0%	0.0%	0.0%	0.0%	0.0%	0.0%	0.0%	0.0%	0.0%	0.0%	0.0%	0.0%
Buses	0	0	0	0	0	0	0	7	1	0	0	8	0	0	0	3	0	0	3	0	0	0	4	2	0	6	0	0	17
% Buses	0.0%	0.0%	0.0%	0.0%	0.0%	0.0%	0.0%	29.2%	1.2%	0.0%	0.0%	0.0%	0.0%	0.0%	0.0%	15.8%	0.0%	0.0%	0.0%	0.0%	0.0%	0.0%	3.8%	4.2%	0.0%	0.0%	0.0%	0.0%	6.0%
Pedestrians	0	0	0	0	0	0	0	0	0	0	0	3	1	1	0	0	0	0	1	0	0	0	0	0	0	0	0	0	0
% Pedestrians	0.0%	0.0%	0.0%	0.0%	0.0%	0.0%	0.0%	0.0%	0.0%	0.0%	0.0%	100.0%	100.0%	100.0%	0.0%	0.0%	0.0%	0.0%	0.0%	0.0%	0.0%	0.0%	0.0%	0.0%	0.0%	0.0%	0.0%	0.0%	0.0%
Bicycles on Crosswalk	0	0	0	0	0	0	0	0	0	0	0	0	0	0	0	0	0	0	0	0	0	0	0	0	0	0	0	0	0
% Bicycles on Crosswalk	0.0%	0.0%	0.0%	0.0%	0.0%	0.0%	0.0%	0.0%	0.0%	0.0%	0.0%	0.0%	0.0%	0.0%	0.0%	0.0%	0.0%	0.0%	0.0%	0.0%	0.0%	0.0%	0.0%	0.0%	0.0%	0.0%	0.0%	0.0%	0.0%

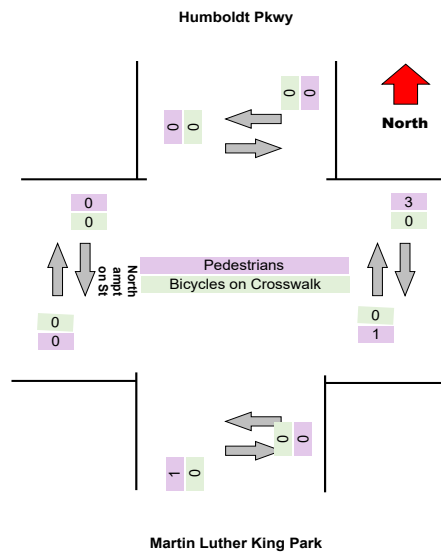
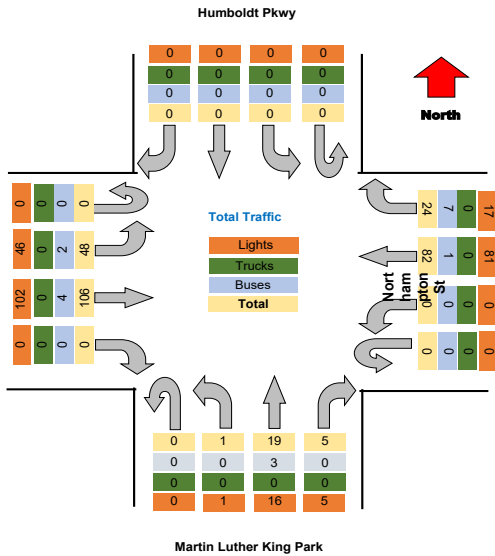

Project : VBH Malta NY  
Site : Site 4  
Location : 42.948550, -73.790036

TSTData.com

Survey Date : 2021-04-28, Wednesday

Project	Labella
Project Code	Labella
Site Name	5
Legs and Movements	All Processed Legs & Move
Bin Size	15 minutes
Survey Date	2021-10-27, Wednesday
Location	5
Latitude and Longitude	42.907349, -78.843174

	Start	End	PHF
Forced Peak AM	2021/10/27 07:30:00	2021/10/27 08:30:00	0.78
Forced Peak PM	2021/10/27 16:30:00	2021/10/27 17:30:00	0.92
AM Peak	2021/10/27 07:30:00	2021/10/27 08:30:00	0.78
PM Peak	2021/10/27 16:15:00	2021/10/27 17:15:00	0.91

### Turning Movement Data

Leg Direction	Humboldt Pkwy						Northampton St						Martin Luther King Park						Northampton St						Total					
	Southbound			Northbound			Westbound			Eastbound			Northbound			Eastbound														
	Right	Thru	Left	U-Turn	App Total	Peds CV	Peds CCV	Right	Thru	Left	U-Turn	App Total	Peds CV	Peds CCV	Right	Thru	Left	U-Turn	App Total	Peds CV	Peds CCV	Right	Thru	Left		U-Turn	App Total	Peds CV	Peds CCV	
Start Time																														
6:30:00 AM	0	0	0	0	0	0	0	0	4	0	0	4	2	0	0	0	1	0	0	3	0	0	0	4	3	0	7	0	0	14
6:45:00 AM	0	0	0	0	0	1	0	2	13	0	0	15	0	0	0	0	0	0	0	0	0	0	0	7	2	0	9	1	0	24
Hourly Total	0	0	0	0	0	1	0	2	17	0	0	19	2	0	0	1	0	0	3	0	0	0	11	5	0	16	1	0	38	
7:00:00 AM	0	0	0	0	0	0	0	1	8	0	0	9	0	0	0	2	0	0	2	0	0	0	10	2	0	12	0	0	23	
7:15:00 AM	0	0	0	0	0	0	0	5	9	0	0	14	0	0	1	4	0	0	5	0	0	0	4	3	0	7	0	0	26	
7:30:00 AM	0	0	0	0	0	2	0	5	15	1	0	21	0	0	0	5	0	0	5	0	0	0	7	3	0	10	0	0	38	
7:45:00 AM	0	0	0	0	0	0	0	4	29	0	0	33	0	0	4	5	0	0	9	0	0	0	18	8	0	26	0	0	68	
Hourly Total	0	0	0	0	0	2	0	15	61	1	0	77	0	0	5	16	0	0	21	0	0	0	39	16	0	55	0	0	153	
8:00:00 AM	0	0	0	0	0	0	0	4	21	0	0	25	0	0	0	6	3	0	9	0	0	0	15	8	0	23	0	0	57	
8:15:00 AM	0	0	0	0	0	0	0	7	8	0	0	16	0	1	3	2	2	0	8	0	0	0	25	1	0	26	0	0	50	
Hourly Total	0	0	0	0	0	0	0	11	29	0	0	41	0	1	3	8	5	0	17	0	0	0	40	9	0	49	0	0	107	
4:00:00 PM	0	0	0	0	0	0	1	4	30	0	0	34	0	0	2	3	0	0	5	0	0	1	20	14	0	35	0	0	74	
4:15:00 PM	0	0	0	0	0	0	1	11	20	0	0	31	0	0	0	7	0	0	7	0	0	0	37	12	0	49	0	0	87	
4:30:00 PM	0	0	0	0	0	0	2	4	28	0	0	32	1	1	2	0	0	0	2	0	0	1	29	13	0	43	0	0	77	
4:45:00 PM	0	0	0	0	0	1	0	11	25	1	0	37	0	0	1	3	1	0	5	0	0	0	21	7	0	28	0	0	70	
Hourly Total	0	0	0	0	0	1	4	30	103	1	0	134	1	1	5	13	1	0	19	0	0	2	107	46	0	155	0	0	308	
5:00:00 PM	0	0	0	0	0	2	0	7	24	0	0	31	0	2	2	1	1	0	4	0	0	0	38	11	0	49	0	2	84	
5:15:00 PM	0	0	0	0	0	0	1	5	32	1	0	38	1	0	0	3	0	0	3	0	0	0	26	11	0	37	0	0	78	
5:30:00 PM	0	0	0	0	0	0	0	10	21	0	0	31	1	0	2	3	0	0	5	1	0	0	27	5	0	32	0	0	68	
5:45:00 PM	0	0	0	0	0	0	0	8	26	0	0	34	0	4	1	1	1	0	3	0	0	0	25	9	0	34	0	0	71	
Hourly Total	0	0	0	0	0	2	1	30	103	1	0	134	2	6	5	8	2	0	15	1	0	0	116	36	0	152	0	2	301	
Grand Total	0	0	0	0	0	6	6	88	313	3	0	405	5	8	18	46	8	0	75	1	0	2	313	112	0	427	1	2	907	
% Approach	0.0%	0.0%	0.0%	0.0%	0.0%	0.0%	0.0%	21.7%	77.3%	0.7%	0.0%	0.0%	0.0%	0.0%	24.0%	61.3%	10.7%	0.0%	0.0%	0.0%	0.0%	0.5%	73.3%	26.2%	0.0%	0.0%	0.0%	0.0%	0.0%	
% Total	0.0%	0.0%	0.0%	0.0%	0.0%	0.0%	0.0%	8.7%	34.5%	0.3%	0.0%	44.7%	0.0%	0.0%	2.0%	5.1%	0.9%	0.0%	8.3%	0.0%	0.0%	0.2%	34.5%	12.3%	0.0%	47.1%	0.0%	0.0%	0.0%	
Lights	0	0	0	0	0	0	0	70	297	3	0	370	0	0	18	42	8	0	68	0	0	2	306	105	0	413	0	0	851	
% Lights	0.0%	0.0%	0.0%	0.0%	0.0%	0.0%	0.0%	79.5%	94.9%	100.0%	0.0%	91.4%	0.0%	0.0%	100.0%	91.3%	100.0%	0.0%	90.7%	0.0%	0.0%	100.0%	97.8%	93.8%	0.0%	96.7%	0.0%	0.0%	93.8%	
Trucks	0	0	0	0	0	0	0	0	0	0	0	0	0	0	0	0	0	0	0	0	0	0	0	0	0	0	0	0	0	
% Trucks	0.0%	0.0%	0.0%	0.0%	0.0%	0.0%	0.0%	0.0%	0.0%	0.0%	0.0%	0.0%	0.0%	0.0%	0.0%	0.0%	0.0%	0.0%	0.0%	0.0%	0.0%	0.0%	0.0%	0.0%	0.0%	0.0%	0.0%	0.0%	0.0%	
Buses	0	0	0	0	0	0	0	18	15	0	0	33	0	0	0	4	0	0	4	0	0	0	6	7	0	13	0	0	50	
% Buses	0.0%	0.0%	0.0%	0.0%	0.0%	0.0%	0.0%	0.0%	4.8%	0.0%	0.0%	0.0%	0.0%	0.0%	0.0%	8.7%	0.0%	0.0%	0.0%	0.0%	0.0%	0.0%	1.9%	6.3%	0.0%	0.0%	0.0%	0.0%	5.5%	
Pedestrians	0	0	0	0	0	6	6	0	0	0	0	0	5	8	0	0	0	0	0	1	0	0	0	0	0	0	1	2	0	
% Pedestrians	0.0%	0.0%	0.0%	0.0%	0.0%	100.0%	100.0%	0.0%	0.0%	0.0%	0.0%	0.0%	100.0%	100.0%	0.0%	0.0%	0.0%	0.0%	0.0%	100.0%	0.0%	0.0%	0.0%	0.0%	0.0%	0.0%	100.0%	100.0%	0.0%	
Bicycles on Crosswalk	0	0	0	0	0	0	0	0	0	0	0	0	0	0	0	0	0	0	0	0	0	0	0	0	0	0	0	0	0	
% Bicycles on Crosswalk	0.0%	0.0%	0.0%	0.0%	0.0%	0.0%	0.0%	0.0%	0.0%	0.0%	0.0%	0.0%	0.0%	0.0%	0.0%	0.0%	0.0%	0.0%	0.0%	0.0%	0.0%	0.0%	0.0%	0.0%	0.0%	0.0%	0.0%	0.0%	0.0%	

Project : VBH Malta NY  
 Site : Site 4  
 Location : 42.948550, -73.790036  
 Survey Date : 2021-04-28, Wednesday

**Turning Movement Data Plot**

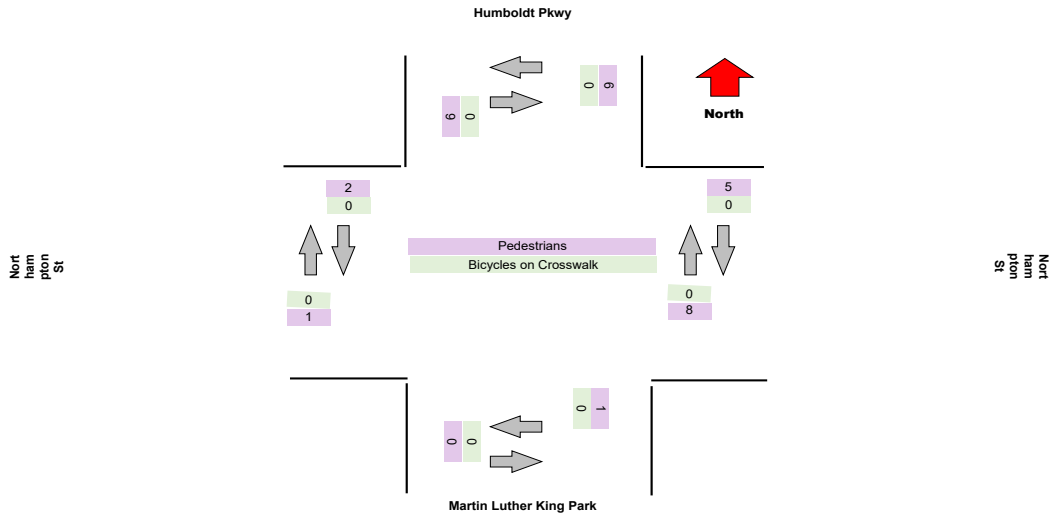
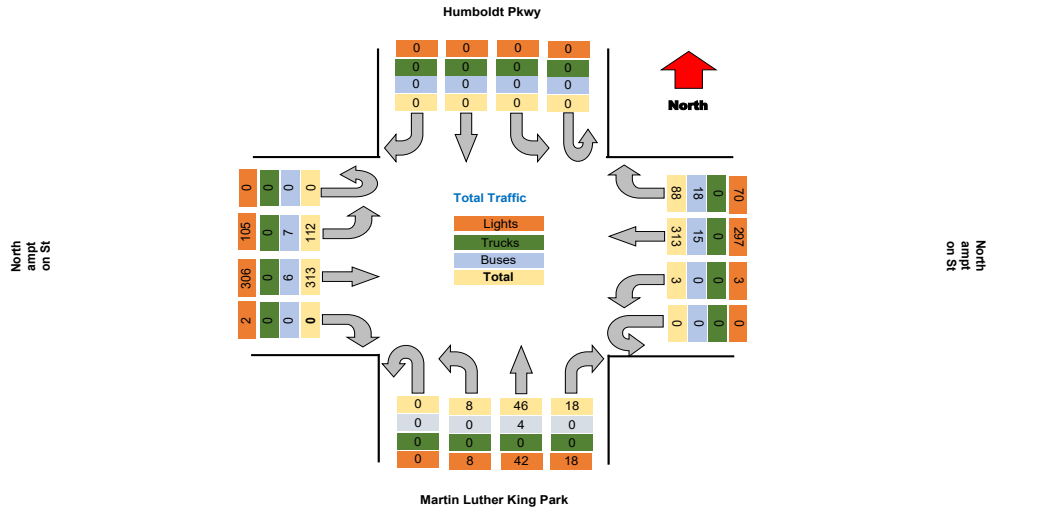

Project : VBH Malta NY  
Site : Site 4  
Location : 42.948550, -73.790036

TSTData.com

Survey Date : 2021-04-28, Wednesday

**Turning Movement Peak Hour Data (AM)**

7:30:00 AM

Leg Direction	Humboldt Pkwy								Northampton St								Martin Luther King Park								Northampton St								Total
	Southbound				Northbound				Westbound				Eastbound				Northbound				Eastbound												
Start Time	Right	Thru	Left	U-Turn	App Total	Peds CW	Peds CCW		Right	Thru	Left	U-Turn	App Total	Peds CW	Peds CCW		Right	Thru	Left	U-Turn	App Total	Peds CW	Peds CCW		Right	Thru	Left	U-Turn	App Total	Peds CW	Peds CCW		
7:30:00 AM	0	0	0	0	0	2	0		5	15	1	0	21	0	0		0	5	0	0	5	0	0		0	7	3	0	10	0	0		36
7:45:00 AM	0	0	0	0	0	0	0		4	29	0	0	33	0	0		4	5	0	0	9	0	0		0	18	8	0	26	0	0		68
8:00:00 AM	0	0	0	0	0	0	0		4	21	0	0	25	0	0		0	6	3	0	9	0	0		0	15	8	0	23	0	0		57
8:15:00 AM	0	0	0	0	0	0	0		7	5	0	0	12	0	0		3	2	2	0	7	0	0		0	25	1	0	26	0	0		50
<b>Grand Total</b>	0	0	0	0	0	2	0		29	73	1	0	95	0	0		7	19	5	0	31	0	0		0	65	20	0	85	0	0		211
% Approach	#DIV/0!	#DIV/0!	#DIV/0!	#DIV/0!	0.0%	0.0%	0.0%		14.2%	85.8%	0.0%	0.0%	0.0%	0.0%	0.0%		45.1%	41.7%	13.2%	0.0%	0.0%	0.0%	0.0%		0.0%	66.2%	33.8%	0.0%	0.0%	0.0%	0.0%		
% Total	0.0%	0.0%	0.0%	0.0%	0.0%	0.0%	0.0%		9.5%	34.6%	0.5%	0.0%	45.0%	0.0%	0.0%		3.3%	8.5%	2.4%	0.0%	14.7%	0.0%	0.0%		0.0%	30.8%	9.5%	0.0%	40.3%	0.0%	0.0%		
PHF	0.000	0.000	0.000	0.000	0.000	0.000	0.000		0.714	0.629	0.250	0.000	0.720	0.000	0.000		0.438	0.750	0.417	0.000	0.861	0.000	0.000		0.000	0.650	0.625	0.000	0.817	0.000	0.000		0.776
Lights	0	0	0	0	0	0	0		13	64	1	0	78	0	0		7	17	5	0	29	0	0		0	63	19	0	82	0	0		189
% Lights	0.0%	0.0%	0.0%	0.0%	0.0%	0.0%	0.0%		85.0%	87.7%	100.0%	0.0%	82.1%	0.0%	0.0%		100.0%	94.4%	100.0%	0.0%	93.5%	0.0%	0.0%		0.0%	96.9%	95.0%	0.0%	96.5%	0.0%	0.0%		89.6%
Trucks	0	0	0	0	0	0	0		0	0	0	0	0	0	0		0	0	0	0	0	0	0		0	0	0	0	0	0	0		0
% Trucks	0.0%	0.0%	0.0%	0.0%	0.0%	0.0%	0.0%		0.0%	0.0%	0.0%	0.0%	0.0%	0.0%	0.0%		0.0%	0.0%	0.0%	0.0%	0.0%	0.0%	0.0%		0.0%	0.0%	0.0%	0.0%	0.0%	0.0%	0.0%		0.0%
Buses	0	0	0	0	0	0	0		7	9	0	0	16	0	0		0	1	0	0	1	0	0		0	2	1	0	3	0	0		20
% Buses	0.0%	0.0%	0.0%	0.0%	0.0%	0.0%	0.0%		35.0%	12.3%	0.0%	0.0%	0.0%	0.0%	0.0%		0.0%	5.8%	0.0%	0.0%	0.0%	0.0%	0.0%		0.0%	3.1%	5.0%	0.0%	0.0%	0.0%	0.0%		9.5%
Pedestrians	0	0	0	0	2	1	0		0	0	0	0	0	0	0		0	0	0	0	0	0	0		0	0	0	0	0	0	0		0
% Pedestrians	0.0%	0.0%	0.0%	0.0%	100.0%	100.0%	0.0%		0.0%	0.0%	0.0%	0.0%	0.0%	0.0%	0.0%		0.0%	0.0%	0.0%	0.0%	0.0%	0.0%	0.0%		0.0%	0.0%	0.0%	0.0%	0.0%	0.0%	0.0%		0.0%
Bicycles on Crosswalk	0	0	0	0	0	0	0		0	0	0	0	0	0	0		0	0	0	0	0	0	0		0	0	0	0	0	0	0		0
% Bicycles on Crosswalk	0.0%	0.0%	0.0%	0.0%	0.0%	0.0%	0.0%		0.0%	0.0%	0.0%	0.0%	0.0%	0.0%	0.0%		0.0%	0.0%	0.0%	0.0%	0.0%	0.0%	0.0%		0.0%	0.0%	0.0%	0.0%	0.0%	0.0%	0.0%		0.0%

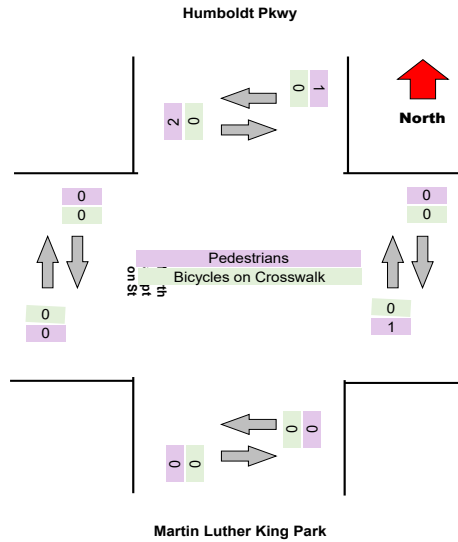
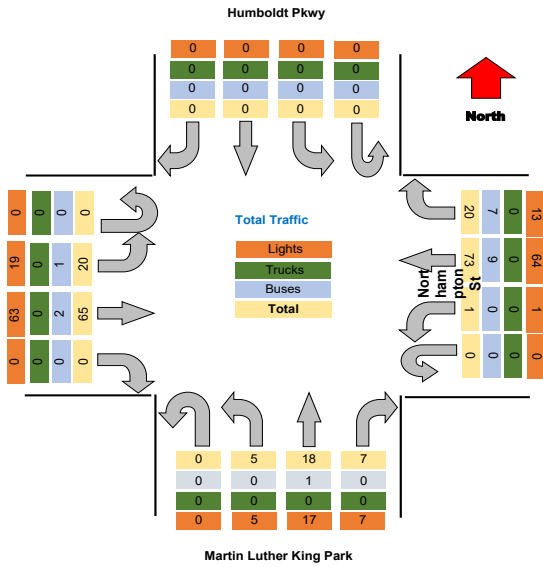



**Turning Movement Peak Hour Data (PM)**

4:15:00 PM

Leg Direction	Humboldt Pkwy										Northampton St										Martin Luther King Park										Northampton St										Total
	Southbound					Westbound					Northbound					Eastbound					Northbound					Eastbound															
	Right	Thru	Left	U-Turn	App Total	Right	Thru	Left	U-Turn	App Total	Right	Thru	Left	U-Turn	App Total	Right	Thru	Left	U-Turn	App Total	Right	Thru	Left	U-Turn	App Total	Right	Thru	Left	U-Turn	App Total	Right	Thru	Left	U-Turn	App Total						
4:15:00 PM	0	0	0	0	0	11	20	0	0	31	0	7	0	0	7	0	0	0	0	0	0	37	12	0	49	0	0	0	0	0	0	0	0	0	0	87					
4:30:00 PM	0	0	0	0	0	4	28	0	0	32	1	1	1	1	4	2	0	0	0	2	0	0	0	0	0	1	29	13	0	43	0	0	0	0	0	77					
4:45:00 PM	0	0	0	0	0	11	25	1	0	37	0	0	0	0	0	1	3	1	0	5	0	0	0	0	0	0	21	7	0	28	0	0	0	0	0	70					
5:00:00 PM	0	0	0	0	0	7	24	0	0	31	0	2	2	2	6	2	1	1	0	4	0	0	0	0	0	0	38	11	0	49	0	0	0	0	0	84					
Grand Total	0	0	0	0	0	33	97	1	0	131	1	3	3	3	10	5	11	2	0	18	0	1	125	43	0	1	125	39	0	165	0	0	0	0	0	318					
% Approach	#DIV/0!	#DIV/0!	#DIV/0!	#DIV/0!	0.0%	14.2%	85.8%	0.0%	0.0%	0.0%	45.1%	41.7%	13.2%	0.0%	0.0%	0.0%	66.2%	33.8%	0.0%	0.0%	0.0%	66.2%	33.8%	0.0%	0.0%	0.0%	0.0%	0.0%	0.0%	0.0%	0.0%	0.0%	0.0%	0.0%	0.0%						
% Total	0.0%	0.0%	0.0%	0.0%	0.0%	10.4%	30.5%	0.3%	0.0%	41.2%	1.6%	3.5%	0.6%	0.0%	5.7%	0.3%	39.3%	13.5%	0.0%	53.1%	0.3%	39.3%	13.5%	0.0%	53.1%	0.0%	0.0%	0.0%	0.0%	0.0%	0.0%	0.0%	0.0%	0.0%	0.0%						
PHF	0.000	0.000	0.000	0.000	0.000	0.750	0.866	0.250	0.000	0.885	0.625	0.393	0.500	0.000	0.643	0.250	0.822	0.827	0.000	0.862	0.250	0.822	0.827	0.000	0.862	0.000	0.000	0.000	0.000	0.000	0.000	0.000	0.000	0.000	0.000						
Lights	0	0	0	0	0	27	96	1	0	124	0	0	0	0	0	5	8	2	0	15	0	1	123	39	0	1	123	39	0	163	0	0	0	0	0	302					
% Lights	0.0%	0.0%	0.0%	0.0%	0.0%	81.8%	99.0%	100.0%	0.0%	94.7%	100.0%	72.7%	100.0%	0.0%	83.3%	100.0%	98.4%	90.7%	0.0%	96.4%	100.0%	98.4%	90.7%	0.0%	96.4%	0.0%	0.0%	0.0%	0.0%	0.0%	0.0%	0.0%	0.0%	0.0%	0.0%						
Trucks	0	0	0	0	0	0	0	0	0	0	0	0	0	0	0	0	0	0	0	0	0	0	0	0	0	0	0	0	0	0	0	0	0	0	0	0					
% Trucks	0.0%	0.0%	0.0%	0.0%	0.0%	0.0%	0.0%	0.0%	0.0%	0.0%	0.0%	0.0%	0.0%	0.0%	0.0%	0.0%	0.0%	0.0%	0.0%	0.0%	0.0%	0.0%	0.0%	0.0%	0.0%	0.0%	0.0%	0.0%	0.0%	0.0%	0.0%	0.0%	0.0%	0.0%	0.0%						
Buses	0	0	0	0	0	6	1	0	0	7	0	0	0	0	0	0	3	0	0	3	0	2	4	0	6	0	0	0	0	0	0	0	0	0	0	16					
% Buses	0.0%	0.0%	0.0%	0.0%	0.0%	18.2%	1.0%	0.0%	0.0%	5.3%	0.0%	0.0%	0.0%	0.0%	0.0%	0.0%	27.3%	0.0%	0.0%	16.7%	0.0%	1.6%	9.3%	0.0%	11.5%	0.0%	0.0%	0.0%	0.0%	0.0%	5.0%	0.0%	0.0%	0.0%	0.0%						
Pedestrians	0	0	0	0	0	3	3	0	0	6	1	3	0	0	4	0	0	0	0	0	0	0	0	0	0	0	0	0	0	0	0	0	0	0	0	2					
% Pedestrians	0.0%	0.0%	0.0%	0.0%	0.0%	100.0%	100.0%	0.0%	0.0%	4.6%	100.0%	100.0%	0.0%	0.0%	26.7%	0.0%	0.0%	0.0%	0.0%	22.2%	0.0%	0.0%	0.0%	0.0%	0.0%	0.0%	0.0%	0.0%	0.0%	0.0%	0.0%	0.0%	0.0%	0.0%	0.0%						
Bicycles on Crosswalk	0	0	0	0	0	0	0	0	0	0	0	0	0	0	0	0	0	0	0	0	0	0	0	0	0	0	0	0	0	0	0	0	0	0	0	0					
% Bicycles on Crosswalk	0.0%	0.0%	0.0%	0.0%	0.0%	0.0%	0.0%	0.0%	0.0%	0.0%	0.0%	0.0%	0.0%	0.0%	0.0%	0.0%	0.0%	0.0%	0.0%	0.0%	0.0%	0.0%	0.0%	0.0%	0.0%	0.0%	0.0%	0.0%	0.0%	0.0%	0.0%	0.0%	0.0%	0.0%	0.0%						

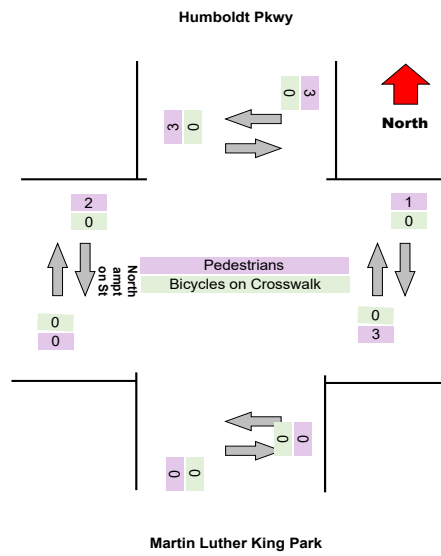
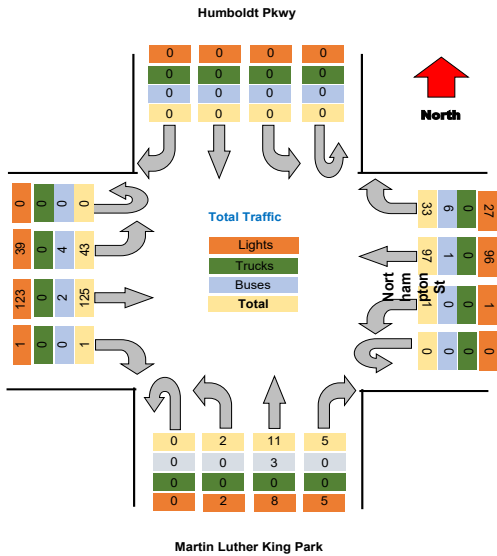



Project : VBH Malta NY  
 Site : Site 4  
 Location : 42.948550, -73.790036  
 Survey Date : 2021-04-28, Wednesday

### Turning Movement Data Plot

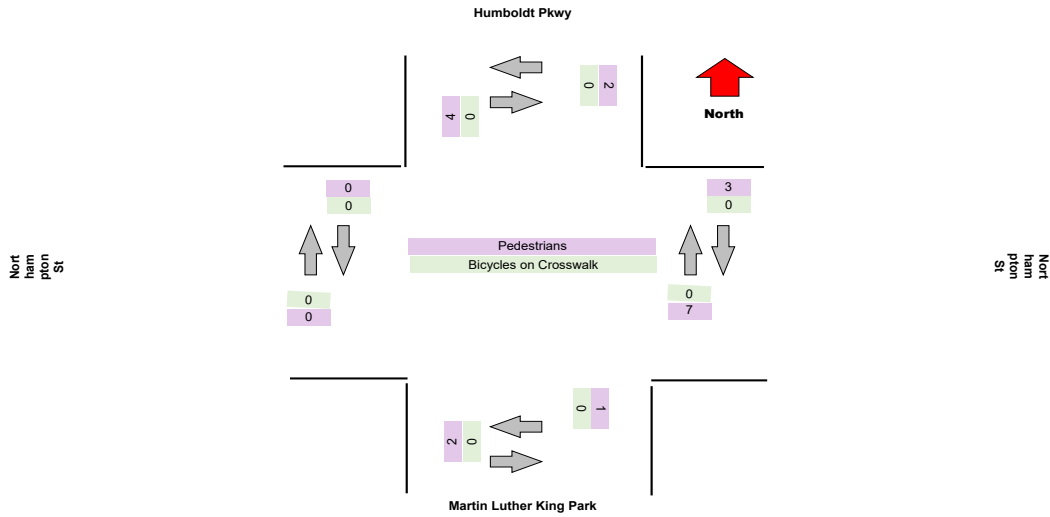
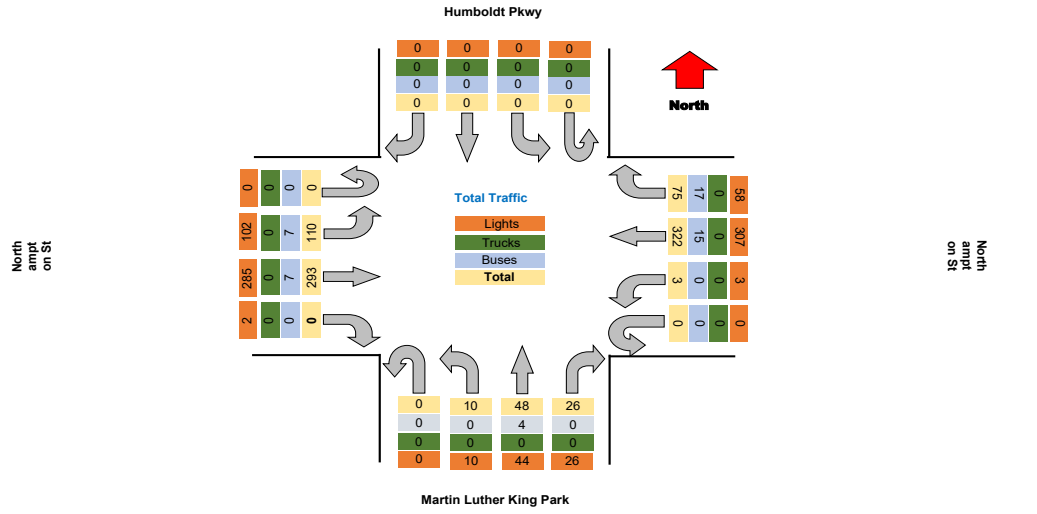

**Turning Movement Peak Hour Data (AM)**

7:30:00 AM

Leg Direction	Humboldt Pkwy								Northampton St								Martin Luther King Park								Northampton St								Total
	Southbound				Westbound				Northbound				Eastbound				Northbound				Eastbound												
Start Time	Right	Thru	Left	U-Turn	App Total	Peds CW	Peds CCW		Right	Thru	Left	U-Turn	App Total	Peds CW	Peds CCW		Right	Thru	Left	U-Turn	App Total	Peds CW	Peds CCW		Right	Thru	Left	U-Turn	App Total	Peds CW	Peds CCW		
7:30:00 AM	0	0	0	0	0	2	1		2	19	0	0	22	0	0		0	2	0	0	2	0	0		0	6	3	0	9	0	0		33
7:45:00 AM	0	0	0	0	0	0	0		5	24	0	0	29	0	0		2	3	1	0	6	0	0		0	29	11	0	40	0	0		75
8:00:00 AM	0	0	0	0	0	0	0		10	23	1	0	34	0	0		1	9	2	0	12	0	0		0	15	9	0	24	0	0		70
8:15:00 AM	0	0	0	0	0	0	0		3	14	0	0	17	0	0		3	2	0	0	7	0	0		0	14	3	0	17	0	0		41
<b>Grand Total</b>	0	0	0	0	0	2	1		29	80	1	0	102	0	0		6	16	3	0	27	0	0		0	64	26	0	90	0	0		219
% Approach	#DIV/0!	#DIV/0!	#DIV/0!	#DIV/0!	0.0%	0.0%	0.0%		14.2%	85.8%	0.0%	0.0%	0.0%	0.0%	0.0%		45.1%	41.7%	13.2%	0.0%	0.0%	0.0%	0.0%		0.0%	66.2%	33.8%	0.0%	0.0%	0.0%	0.0%		
% Total	0.0%	0.0%	0.0%	0.0%	0.0%	0.0%	0.0%		9.1%	36.5%	0.5%	0.0%	46.6%	0.0%	0.0%		2.7%	7.3%	1.4%	0.0%	12.3%	0.0%	0.0%		0.0%	29.2%	11.9%	0.0%	41.1%	0.0%	0.0%		
PHF	0.000	0.000	0.000	0.000	0.000	0.000	0.000		0.500	0.833	0.250	0.000	0.750	0.000	0.000		0.500	0.444	0.375	0.000	0.563	0.000	0.000		0.000	0.552	0.591	0.000	0.563	0.000	0.000		0.730
Lights	0	0	0	0	0	0	0		13	70	1	0	84	0	0		6	15	3	0	24	0	0		0	62	24	0	86	0	0		194
% Lights	0.0%	0.0%	0.0%	0.0%	0.0%	0.0%	0.0%		85.0%	87.5%	100.0%	0.0%	82.4%	0.0%	0.0%		100.0%	93.8%	100.0%	0.0%	88.9%	0.0%	0.0%		0.0%	96.9%	92.3%	0.0%	95.6%	0.0%	0.0%		88.6%
Trucks	0	0	0	0	0	0	0		0	0	0	0	0	0	0		0	0	0	0	0	0	0		0	0	0	0	0	0	0		0
% Trucks	0.0%	0.0%	0.0%	0.0%	0.0%	0.0%	0.0%		0.0%	0.0%	0.0%	0.0%	0.0%	0.0%	0.0%		0.0%	0.0%	0.0%	0.0%	0.0%	0.0%	0.0%		0.0%	0.0%	0.0%	0.0%	0.0%	0.0%	0.0%		0.0%
Buses	0	0	0	0	0	0	0		7	10	0	0	17	0	0		0	1	0	0	1	0	0		0	2	2	0	4	0	0		22
% Buses	0.0%	0.0%	0.0%	0.0%	0.0%	0.0%	0.0%		35.0%	12.5%	0.0%	0.0%	0.0%	0.0%	0.0%		0.0%	6.3%	0.0%	0.0%	0.0%	0.0%	0.0%		0.0%	3.1%	7.7%	0.0%	0.0%	0.0%	0.0%		10.0%
Pedestrians	0	0	0	0	2	1	0		0	0	0	0	0	2	0		0	0	0	0	0	0	0		0	0	0	0	0	0	0		0
% Pedestrians	0.0%	0.0%	0.0%	0.0%	100.0%	100.0%	0.0%		0.0%	0.0%	0.0%	0.0%	0.0%	100.0%	0.0%		0.0%	0.0%	0.0%	0.0%	0.0%	0.0%	0.0%		0.0%	0.0%	0.0%	0.0%	0.0%	0.0%	0.0%		0.0%
Bicycles on Crosswalk	0	0	0	0	0	0	0		0	0	0	0	0	0	0		0	0	0	0	0	0	0		0	0	0	0	0	0	0		0
% Bicycles on Crosswalk	0.0%	0.0%	0.0%	0.0%	0.0%	0.0%	0.0%		0.0%	0.0%	0.0%	0.0%	0.0%	0.0%	0.0%		0.0%	0.0%	0.0%	0.0%	0.0%	0.0%	0.0%		0.0%	0.0%	0.0%	0.0%	0.0%	0.0%	0.0%		0.0%

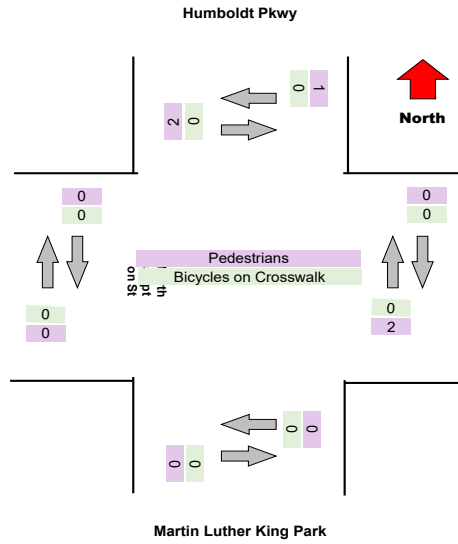
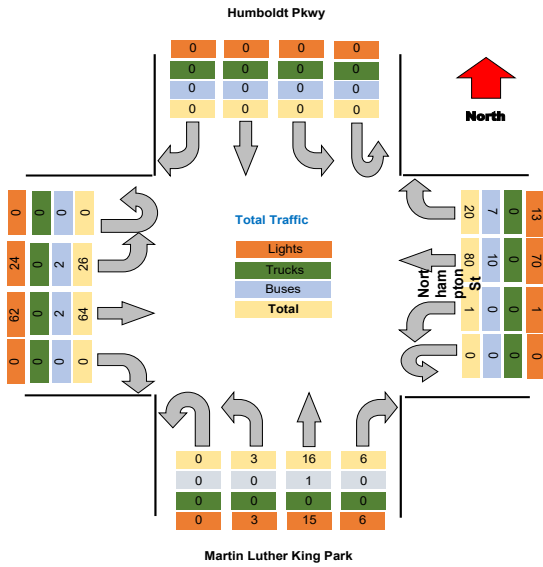

Project : VBH Malta NY  
Site : Site 4  
Location : 42.948550, -73.790036

TSTData.com

Survey Date : 2021-04-28, Wednesday

### Turning Movement Peak Hour Data (PM)

4:15:00 PM

Leg Direction	Humboldt Pkwy										Northampton St					Martin Luther King Park					Northampton St					Total										
	Southbound					Westbound					Northbound					Eastbound																				
	Right	Thru	Left	U-Turn	App Total	Peds CW	Peds CCW	Right	Thru	Left	U-Turn	App Total	Peds CW	Peds CCW	Right	Thru	Left	U-Turn	App Total	Peds CW	Peds CCW	Right	Thru	Left	U-Turn		App Total	Peds CW	Peds CCW							
4:15:00 PM	0	0	0	0	0	0	0	1	6	27	0	0	33	0	0	0	0	0	0	0	0	3	2	1	0	6	0	0	0	33	13	0	46	0	0	85
4:30:00 PM	0	0	0	0	0	0	0	0	9	28	0	0	37	0	0	0	0	0	0	0	0	1	2	0	0	3	1	0	0	21	16	0	37	0	0	77
4:45:00 PM	0	0	0	0	0	0	0	0	7	28	0	0	35	0	0	0	0	0	0	0	0	1	3	1	0	5	0	0	0	15	6	0	21	0	0	61
5:00:00 PM	0	0	0	0	0	0	0	0	3	21	0	0	24	0	0	0	0	0	0	0	0	2	8	0	0	10	0	0	0	33	7	0	40	0	0	74
Grand Total	0	0	0	0	0	0	0	0	25	104	0	0	129	0	0	0	0	0	0	0	7	15	2	0	24	1	0	0	102	42	0	144	3	0	297	
% Approach	#DIV/0!	#DIV/0!	#DIV/0!	#DIV/0!	0.0%	0.0%	0.0%	0.0%	14.2%	85.8%	0.0%	0.0%	0.0%	0.0%	0.0%	0.0%	0.0%	0.0%	0.0%	0.0%	45.1%	41.7%	13.2%	0.0%	0.0%	0.0%	0.0%	0.0%	66.2%	33.8%	0.0%	0.0%	0.0%	0.0%	0.0%	
% Total	0.0%	0.0%	0.0%	0.0%	0.0%	0.0%	0.0%	0.0%	8.4%	35.0%	0.0%	0.0%	43.4%	0.0%	0.0%	0.0%	0.0%	0.0%	0.0%	0.0%	2.4%	5.1%	0.7%	0.0%	8.1%	0.0%	0.0%	0.0%	34.3%	14.1%	0.0%	48.5%	0.0%	0.0%	0.0%	
PHF	0.000	0.000	0.000	0.000	0.000	0.000	0.000	0.000	0.694	0.929	0.000	0.000	0.872	0.000	0.000	0.000	0.000	0.000	0.000	0.583	0.469	0.500	0.000	0.600	0.000	0.000	0.000	0.773	0.656	0.000	0.783	0.000	0.000	0.874		
Lights	0	0	0	0	0	0	0	0	20	102	0	0	122	0	0	0	0	0	0	0	7	13	2	0	22	0	0	0	100	38	0	138	0	0	282	
% Lights	0.0%	0.0%	0.0%	0.0%	0.0%	0.0%	0.0%	0.0%	80.0%	98.1%	0.0%	0.0%	94.6%	0.0%	0.0%	0.0%	0.0%	0.0%	0.0%	0.0%	100.0%	86.7%	100.0%	0.0%	91.7%	0.0%	0.0%	0.0%	98.0%	90.5%	0.0%	95.8%	0.0%	0.0%	94.9%	
Trucks	0	0	0	0	0	0	0	0	0	0	0	0	0	0	0	0	0	0	0	0	0	0	0	0	0	0	0	0	0	0	0	0	0	0	0	
% Trucks	0.0%	0.0%	0.0%	0.0%	0.0%	0.0%	0.0%	0.0%	0.0%	0.0%	0.0%	0.0%	0.0%	0.0%	0.0%	0.0%	0.0%	0.0%	0.0%	0.0%	0.0%	0.0%	0.0%	0.0%	0.0%	0.0%	0.0%	0.0%	0.0%	0.0%	0.0%	0.0%	0.0%	0.0%	0.0%	
Buses	0	0	0	0	0	5	2	0	0	7	0	0	7	0	0	0	0	0	0	0	2	2	0	0	2	0	0	0	1	3	0	4	0	0	13	
% Buses	0.0%	0.0%	0.0%	0.0%	0.0%	20.0%	1.9%	0.0%	0.0%	7.0%	0.0%	0.0%	5.4%	0.0%	0.0%	0.0%	0.0%	0.0%	0.0%	0.0%	8.3%	13.3%	0.0%	0.0%	8.3%	0.0%	0.0%	0.0%	1.0%	7.1%	0.0%	2.8%	0.0%	0.0%	4.4%	
Pedestrians	0	0	0	0	0	1	1	0	0	0	0	0	0	0	0	0	0	0	0	0	0	0	1	0	0	0	0	0	0	0	0	0	0	0	0	
% Pedestrians	0.0%	0.0%	0.0%	0.0%	0.0%	100.0%	100.0%	0.0%	0.0%	0.0%	0.0%	0.0%	0.0%	0.0%	0.0%	0.0%	0.0%	0.0%	0.0%	0.0%	0.0%	0.0%	0.0%	0.0%	0.0%	0.0%	0.0%	0.0%	0.0%	0.0%	0.0%	0.0%	0.0%	0.0%	0.0%	
Bicycles on Crosswalk	0	0	0	0	0	0	0	0	0	0	0	0	0	0	0	0	0	0	0	0	0	0	0	0	0	0	0	0	0	0	0	0	0	0	0	
% Bicycles on Crosswalk	0.0%	0.0%	0.0%	0.0%	0.0%	0.0%	0.0%	0.0%	0.0%	0.0%	0.0%	0.0%	0.0%	0.0%	0.0%	0.0%	0.0%	0.0%	0.0%	0.0%	0.0%	0.0%	0.0%	0.0%	0.0%	0.0%	0.0%	0.0%	0.0%	0.0%	0.0%	0.0%	0.0%	0.0%	0.0%	

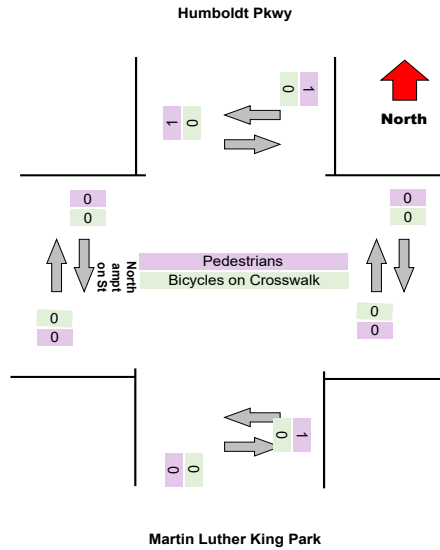
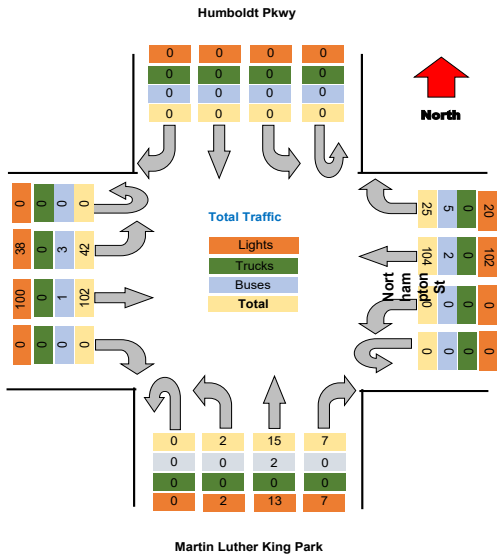



### Turning Movement Data Plot

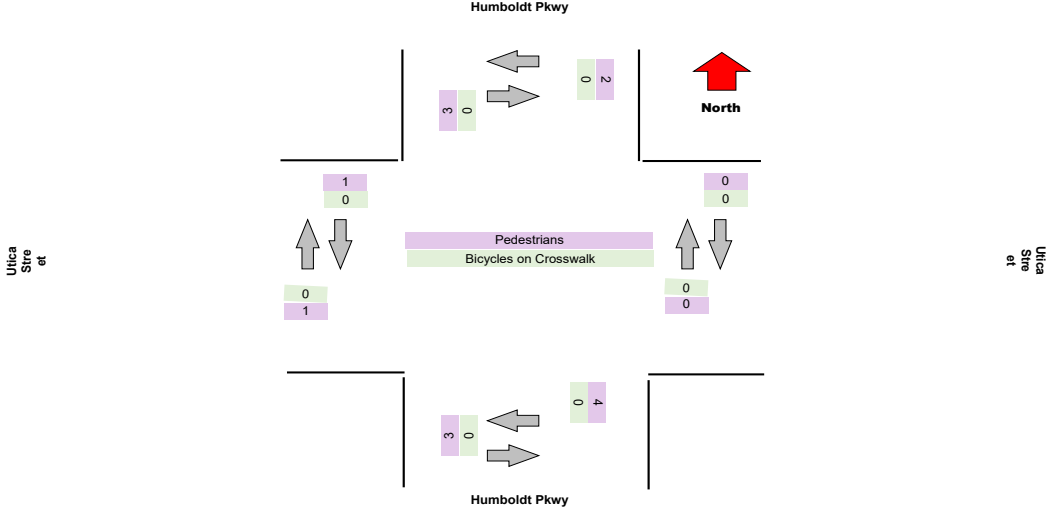
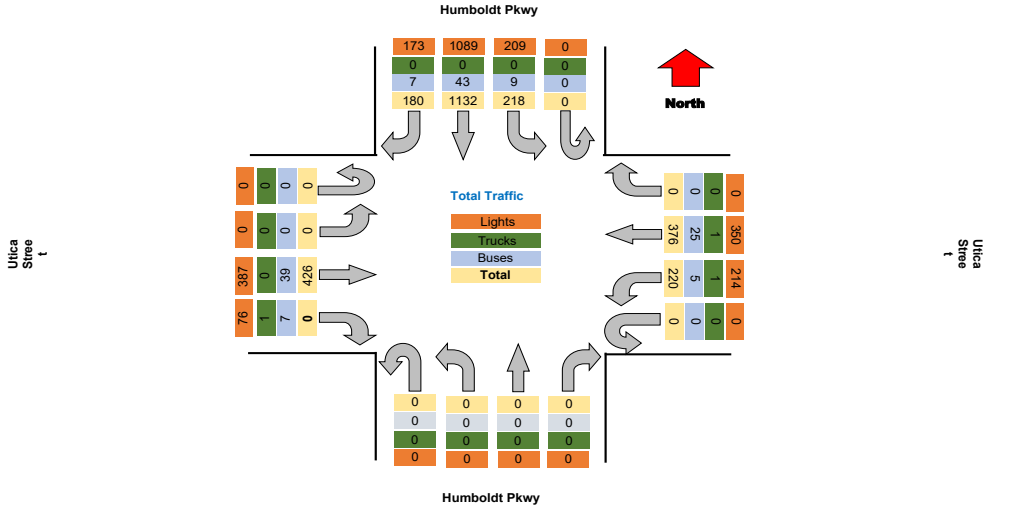

Project : VBH Malta NY  
Site : Site 4  
Location : 42.948550, -73.790036

TSTData.com

Survey Date : 2021-04-28, Wednesday

### Turning Movement Peak Hour Data (AM)

7:30:00 AM

Leg Direction	Humboldt Pkwy										Utica Street										Humboldt Pkwy										Utica Street										Total
	Southbound					Westbound					Northbound					Eastbound																									
Start Time	Right	Thru	Left	U-Turn	App Total	Peds CW	Peds CCW	Right	Thru	Left	U-Turn	App Total	Peds CW	Peds CCW	Right	Thru	Left	U-Turn	App Total	Peds CW	Peds CCW	Right	Thru	Left	U-Turn	App Total	Peds CW	Peds CCW													
7:30:00 AM	12	76	15	0	103	0	0	0	20	17	0	37	0	0	0	0	0	0	0	1	0	0	3	17	0	0	20	0	1												
7:45:00 AM	13	77	11	0	101	0	0	0	22	20	0	42	0	0	0	0	0	0	0	0	0	4	20	0	0	24	0	0													
8:00:00 AM	14	58	10	0	82	0	0	0	28	15	0	43	0	0	0	0	0	0	0	0	0	6	26	0	0	32	0	0													
8:15:00 AM	8	91	12	0	111	0	0	0	29	8	0	39	0	0	0	0	0	0	0	0	0	5	22	0	0	27	0	0													
<b>Grand Total</b>	<b>47</b>	<b>302</b>	<b>48</b>	<b>0</b>	<b>397</b>	<b>0</b>	<b>0</b>	<b>0</b>	<b>99</b>	<b>60</b>	<b>0</b>	<b>159</b>	<b>0</b>	<b>0</b>	<b>0</b>	<b>0</b>	<b>0</b>	<b>0</b>	<b>1</b>	<b>1</b>	<b>0</b>	<b>19</b>	<b>85</b>	<b>0</b>	<b>0</b>	<b>103</b>	<b>0</b>	<b>1</b>													
% Approach	11.8%	76.1%	12.1%	0.0%	0.0%	0.0%	0.0%	14.2%	85.8%	0.0%	0.0%	0.0%	0.0%	0.0%	45.1%	41.7%	13.2%	0.0%	0.0%	0.0%	0.0%	0.0%	66.2%	33.8%	0.0%	0.0%	0.0%	0.0%													
% Total	7.1%	45.7%	7.3%	0.0%	60.1%	0.0%	0.0%	0.0%	15.0%	9.1%	0.0%	24.4%	0.0%	0.0%	0.0%	0.0%	0.0%	0.0%	0.0%	0.0%	0.0%	2.7%	12.9%	0.0%	0.0%	15.6%	0.0%	0.0%													
PHF	0.839	0.830	0.800	0.000	0.894	0.000	0.000	0.000	0.853	0.750	0.000	0.936	0.000	0.000	0.000	0.000	0.000	0.000	0.000	0.000	0.000	0.750	0.817	0.000	0.000	0.805	0.000	0.000													
Lights	44	287	47	0	378	0	0	0	92	57	0	149	0	0	0	0	0	0	0	0	0	17	73	0	0	90	0	0													
% Lights	83.6%	85.0%	97.9%	0.0%	95.2%	0.0%	0.0%	0.0%	92.9%	95.0%	0.0%	92.5%	0.0%	0.0%	0.0%	0.0%	0.0%	0.0%	0.0%	0.0%	0.0%	94.4%	85.9%	0.0%	0.0%	87.4%	0.0%	0.0%													
Trucks	0	0	0	0	0	0	0	0	0	0	0	0	0	0	0	0	0	0	0	0	0	0	0	0	0	0	0	0	0												
% Trucks	0.0%	0.0%	0.0%	0.0%	0.0%	0.0%	0.0%	0.0%	0.0%	0.0%	0.0%	0.0%	0.0%	0.0%	0.0%	0.0%	0.0%	0.0%	0.0%	0.0%	0.0%	0.0%	0.0%	0.0%	0.0%	0.0%	0.0%	0.0%	0.0%												
Buses	3	15	1	0	19	0	0	0	7	3	0	10	0	0	0	0	0	0	0	0	0	1	12	0	0	13	0	0													
% Buses	6.4%	5.0%	2.1%	0.0%	0.0%	0.0%	0.0%	0.0%	7.1%	5.0%	0.0%	0.0%	0.0%	0.0%	0.0%	0.0%	0.0%	0.0%	0.0%	0.0%	0.0%	5.6%	14.1%	0.0%	0.0%	0.0%	0.0%	0.0%													
Pedestrians	0	0	0	0	0	0	2	0	0	0	0	0	0	0	0	0	0	0	1	1	0	0	0	0	0	0	0	1	0												
% Pedestrians	0.0%	0.0%	0.0%	0.0%	0.0%	0.0%	100.0%	0.0%	0.0%	0.0%	0.0%	0.0%	0.0%	0.0%	0.0%	0.0%	0.0%	0.0%	0.0%	100.0%	100.0%	0.0%	0.0%	0.0%	0.0%	0.0%	0.0%	100.0%	0.0%												
Bicycles on Crosswalk	0	0	0	0	0	0	0	0	0	0	0	0	0	0	0	0	0	0	0	0	0	0	0	0	0	0	0	0	0												
% Bicycles on Crosswalk	0.0%	0.0%	0.0%	0.0%	0.0%	0.0%	0.0%	0.0%	0.0%	0.0%	0.0%	0.0%	0.0%	0.0%	0.0%	0.0%	0.0%	0.0%	0.0%	0.0%	0.0%	0.0%	0.0%	0.0%	0.0%	0.0%	0.0%	0.0%	0.0%												

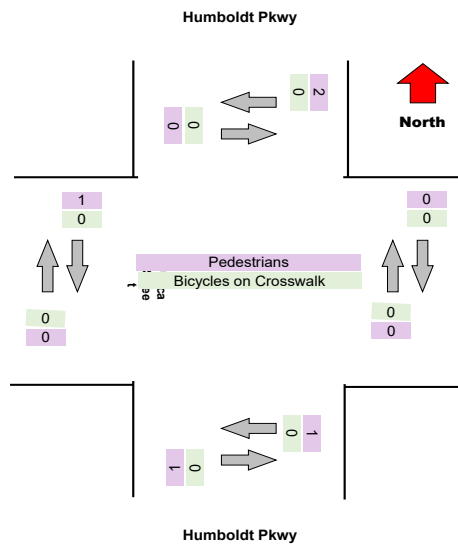
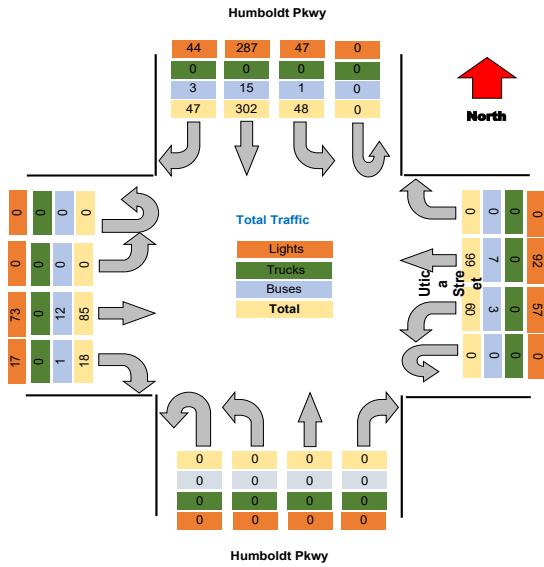



**Turning Movement Peak Hour Data (PM)**

4:15:00 PM

Leg Direction	Humboldt Pkwy								Ulita Street								Humboldt Pkwy								Ulita Street								Total
	Southbound				Westbound				Northbound				Eastbound																				
Start Time	Right	Thru	Left	U-Turn	App Total	Peds CW	Peds CCW	Right	Thru	Left	U-Turn	App Total	Peds CW	Peds CCW	Right	Thru	Left	U-Turn	App Total	Peds CW	Peds CCW	Right	Thru	Left	U-Turn	App Total	Peds CW	Peds CCW					
4:15:00 PM	17	89	15	0	121	0	0	0	28	14	0	42	0	0	0	0	0	0	0	0	0	0	13	39	0	0	52	0	0	215			
4:30:00 PM	15	94	19	0	128	0	0	0	23	12	0	35	0	0	0	0	0	0	0	0	0	0	6	37	0	0	43	0	0	206			
4:45:00 PM	11	87	14	0	112	0	0	0	29	10	0	39	0	0	0	0	0	0	0	0	0	0	6	33	0	0	39	0	0	190			
5:00:00 PM	13	87	20	0	120	0	0	0	31	16	0	47	0	0	0	0	0	0	0	0	0	0	8	29	0	0	37	0	0	204			
<b>Grand Total</b>	<b>56</b>	<b>357</b>	<b>68</b>	<b>0</b>	<b>481</b>	<b>0</b>	<b>0</b>	<b>0</b>	<b>111</b>	<b>52</b>	<b>0</b>	<b>163</b>	<b>0</b>	<b>0</b>	<b>0</b>	<b>0</b>	<b>0</b>	<b>0</b>	<b>0</b>	<b>0</b>	<b>0</b>	<b>33</b>	<b>138</b>	<b>0</b>	<b>0</b>	<b>171</b>	<b>0</b>	<b>0</b>	<b>815</b>				
% Approach	11.6%	74.2%	14.1%	0.0%	0.0%	0.0%	0.0%	14.2%	85.8%	0.0%	0.0%	0.0%	0.0%	0.0%	45.1%	41.7%	13.2%	0.0%	0.0%	0.0%	0.0%	0.0%	66.2%	33.8%	0.0%	0.0%	0.0%	0.0%	0.0%				
% Total	6.9%	43.8%	8.3%	0.0%	59.0%	0.0%	0.0%	0.0%	13.6%	6.4%	0.0%	20.0%	0.0%	0.0%	0.0%	0.0%	0.0%	0.0%	0.0%	0.0%	0.0%	0.0%	4.0%	16.9%	0.0%	0.0%	21.0%	0.0%	0.0%				
PHF	0.824	0.949	0.850	0.000	0.939	0.000	0.000	0.000	0.895	0.813	0.000	0.867	0.000	0.000	0.000	0.000	0.000	0.000	0.000	0.000	0.000	0.000	0.635	0.885	0.000	0.000	0.822	0.000	0.000	0.948			
Lights	53	347	64	0	464	0	0	0	106	51	0	157	0	0	0	0	0	0	0	0	0	30	133	0	0	163	0	0	784				
% Lights	84.6%	97.2%	94.1%	0.0%	96.5%	0.0%	0.0%	0.0%	95.5%	98.1%	0.0%	96.3%	0.0%	0.0%	0.0%	0.0%	0.0%	0.0%	0.0%	0.0%	0.0%	90.9%	96.4%	0.0%	0.0%	95.3%	0.0%	0.0%	96.2%				
Trucks	0	0	0	0	0	0	0	0	0	0	0	0	0	0	0	0	0	0	0	0	0	0	0	0	0	0	0	0	0				
% Trucks	0.0%	0.0%	0.0%	0.0%	0.0%	0.0%	0.0%	0.0%	0.0%	0.0%	0.0%	0.0%	0.0%	0.0%	0.0%	0.0%	0.0%	0.0%	0.0%	0.0%	0.0%	0.0%	0.0%	0.0%	0.0%	0.0%	0.0%	0.0%	0.0%				
Buses	3	10	4	0	17	0	0	0	5	1	0	6	0	0	0	0	0	0	0	0	0	0	3	5	0	0	8	0	0	31			
% Buses	5.4%	2.8%	5.9%	0.0%	0.0%	0.0%	0.0%	0.0%	4.5%	1.9%	0.0%	0.0%	0.0%	0.0%	0.0%	0.0%	0.0%	0.0%	0.0%	0.0%	0.0%	9.1%	3.8%	0.0%	0.0%	0.0%	0.0%	0.0%	3.8%				
Pedestrians	0	0	0	0	0	0	0	0	0	0	0	0	0	0	0	0	0	0	0	0	0	0	0	0	0	0	0	0	0				
% Pedestrians	0.0%	0.0%	0.0%	0.0%	0.0%	0.0%	0.0%	0.0%	0.0%	0.0%	0.0%	0.0%	0.0%	0.0%	0.0%	0.0%	0.0%	0.0%	0.0%	0.0%	0.0%	0.0%	0.0%	0.0%	0.0%	0.0%	0.0%	0.0%	0.0%				
Bicycles on Crosswalk	0	0	0	0	0	0	0	0	0	0	0	0	0	0	0	0	0	0	0	0	0	0	0	0	0	0	0	0	0				
% Bicycles on Crosswalk	0.0%	0.0%	0.0%	0.0%	0.0%	0.0%	0.0%	0.0%	0.0%	0.0%	0.0%	0.0%	0.0%	0.0%	0.0%	0.0%	0.0%	0.0%	0.0%	0.0%	0.0%	0.0%	0.0%	0.0%	0.0%	0.0%	0.0%	0.0%	0.0%				

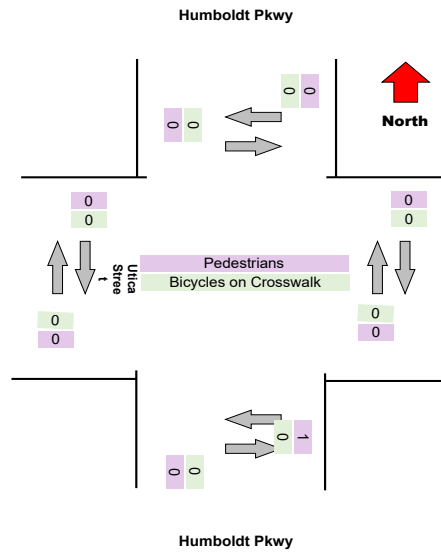
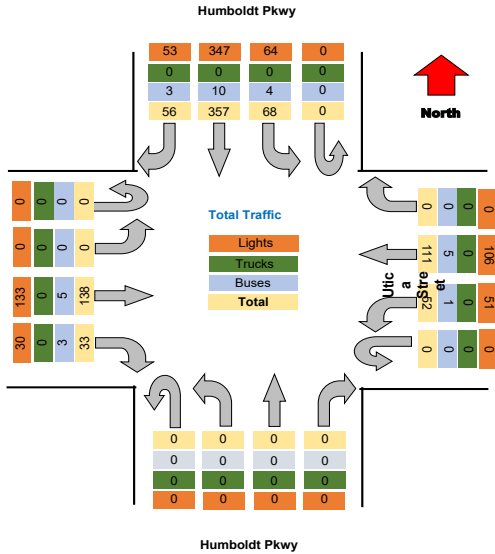

Project : VBH Malta NY  
Site : Site 4  
Location : 42.948550, -73.790036

TSTData.com

Survey Date : 2021-04-28, Wednesday

Project	Labella
Project Code	Labella
Site Name	6
Legs and Movements	All Processed Legs & Move
Bin Size	15 minutes
Survey Date	2021-10-27, Wednesday
Location	6
Latitude and Longitude	42.911017, -78.843680

	Start	End	PHF
Forced Peak AM	2021/10/27 07:30:00	2021/10/27 08:30:00	0.92
Forced Peak PM	2021/10/27 16:30:00	2021/10/27 17:30:00	0.95
AM Peak	2021/10/27 07:30:00	2021/10/27 08:30:00	0.92
PM Peak	2021/10/27 16:15:00	2021/10/27 17:15:00	0.95

### Turning Movement Data

Leg Direction	Humboldt Pkwy				Utica Street				Humboldt Pkwy				Utica Street				Total				
	Southbound		Northbound		Westbound		Eastbound		Northbound		Eastbound		Westbound								
Start Time	Right	Thru	Left	U-Turn	App Total	Peds CV	Peds CCV	Right	Thru	Left	U-Turn	App Total	Peds CV	Peds CCV	Right	Thru	Left	U-Turn	App Total	Peds CV	Peds CCV
6:30:00 AM	1	38	8	0	47	0	0	0	13	7	0	20	0	0	0	0	0	0	0	0	0
6:45:00 AM	3	40	9	0	52	0	0	0	12	8	0	20	0	0	0	0	0	0	0	0	0
Hourly Total	4	78	17	0	99	0	0	0	25	15	0	40	0	0	0	0	0	0	0	0	0
7:00:00 AM	3	34	5	0	42	0	1	0	13	9	0	23	0	0	0	0	0	0	0	0	0
7:15:00 AM	9	39	14	0	62	2	2	0	13	3	0	18	0	0	0	0	0	0	1	0	0
7:30:00 AM	11	71	16	0	98	0	0	0	22	9	0	31	0	0	0	0	0	0	0	0	0
7:45:00 AM	12	80	6	0	98	2	1	0	21	22	0	44	0	0	0	0	0	0	0	2	0
Hourly Total	35	224	41	0	300	4	4	0	69	43	0	116	0	0	0	0	0	0	1	2	0
8:00:00 AM	16	73	10	0	99	1	0	0	24	10	0	34	0	0	0	0	0	0	2	0	0
8:15:00 AM	13	77	15	0	105	0	0	0	33	17	0	50	0	0	0	0	0	0	1	1	0
Hourly Total	29	150	25	0	204	1	0	0	57	27	0	84	0	0	0	0	0	0	3	1	0
4:00:00 PM	12	82	25	0	119	0	0	0	29	17	0	46	0	0	0	0	0	0	0	0	0
4:15:00 PM	17	90	11	0	118	1	0	0	33	15	0	48	0	0	0	0	0	0	0	0	0
4:30:00 PM	11	96	15	0	122	1	1	0	29	18	0	47	0	0	0	0	0	0	0	3	0
4:45:00 PM	10	64	18	0	92	3	0	0	40	14	0	54	2	0	0	0	0	0	2	0	0
Hourly Total	50	332	69	0	451	4	3	0	131	64	0	195	2	0	0	0	0	0	2	3	0
5:00:00 PM	13	80	18	0	111	0	0	0	30	20	0	50	0	0	0	0	0	0	0	0	0
5:15:00 PM	25	71	21	0	117	1	0	0	27	13	0	40	0	0	0	0	0	0	0	0	0
5:30:00 PM	15	72	4	0	91	3	0	0	26	14	0	40	0	1	0	0	0	0	3	0	0
5:45:00 PM	14	66	17	0	97	0	0	0	32	12	0	44	0	0	0	0	0	0	2	0	0
Hourly Total	67	289	60	0	416	4	0	0	115	59	0	174	0	1	0	0	0	0	5	0	0
Grand Total	185	1073	212	0	1470	13	7	0	397	208	0	609	2	1	0	0	0	0	11	6	0
% Approach	12.6%	73.0%	14.4%	0.0%	0.0%	0.0%	0.0%	0.0%	65.2%	34.2%	0.0%	0.0%	0.0%	0.0%	0.0%	0.0%	0.0%	0.0%	0.0%	0.0%	0.0%
% Total	6.9%	40.3%	8.0%	0.0%	55.2%	0.0%	0.0%	0.0%	14.9%	7.8%	0.0%	22.9%	0.0%	0.0%	0.0%	0.0%	0.0%	0.0%	0.0%	0.0%	0.0%
Lights	174	1032	208	0	1412	0	0	0	370	203	0	573	0	0	0	0	0	0	0	0	0
% Lights	94.1%	96.2%	97.2%	0.0%	96.1%	0.0%	0.0%	0.0%	93.2%	97.6%	0.0%	94.1%	0.0%	0.0%	0.0%	0.0%	0.0%	0.0%	0.0%	0.0%	0.0%
Trucks	0	0	0	0	0	0	0	0	0	0	0	0	0	0	0	0	0	0	0	0	0
% Trucks	0.0%	0.0%	0.0%	0.0%	0.0%	0.0%	0.0%	0.0%	0.0%	0.0%	0.0%	0.0%	0.0%	0.0%	0.0%	0.0%	0.0%	0.0%	0.0%	0.0%	0.0%
Buses	11	40	6	0	57	0	0	0	27	5	0	32	0	0	0	0	0	0	0	0	0
% Buses	5.9%	3.7%	2.8%	0.0%	0.0%	0.0%	0.0%	0.0%	6.8%	2.4%	0.0%	0.0%	0.0%	0.0%	0.0%	0.0%	0.0%	0.0%	0.0%	0.0%	0.0%
Pedestrians	0	0	0	0	0	13	7	0	0	0	0	0	2	1	0	0	0	0	11	6	0
% Pedestrians	0.0%	0.0%	0.0%	0.0%	0.0%	100.0%	100.0%	0.0%	0.0%	0.0%	0.0%	0.0%	100.0%	100.0%	0.0%	0.0%	0.0%	0.0%	83.3%	100.0%	0.0%
Bicycles on Crosswalk	0	0	0	0	0	0	0	0	0	0	0	0	0	0	0	0	0	0	0	1	0
% Bicycles on Crosswalk	0.0%	0.0%	0.0%	0.0%	0.0%	0.0%	0.0%	0.0%	0.0%	0.0%	0.0%	0.0%	0.0%	0.0%	0.0%	0.0%	0.0%	0.0%	0.0%	16.7%	0.0%

Project : VBH Malta NY  
 Site : Site 4  
 Location : 42.948550, -73.790036  
 Survey Date : 2021-04-28, Wednesday

### Turning Movement Data Plot

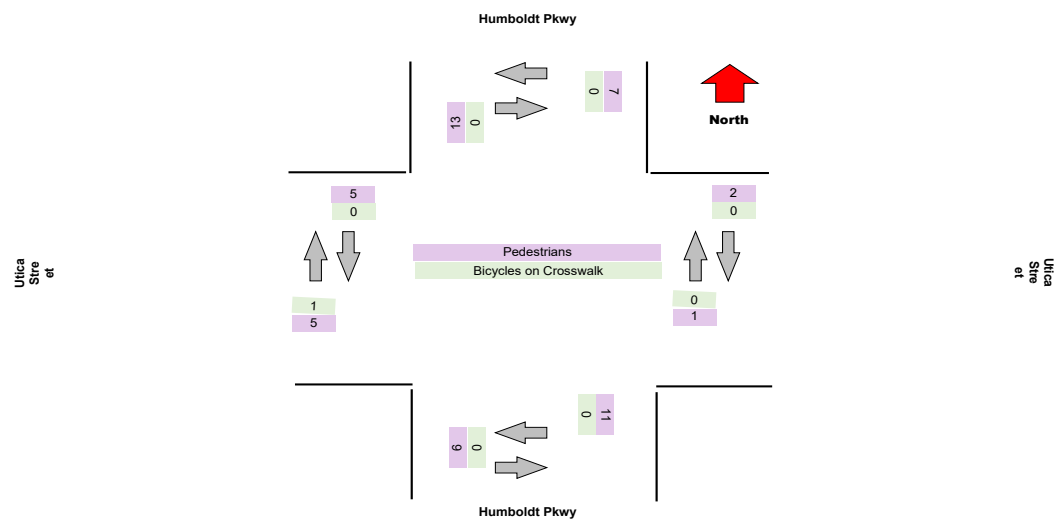
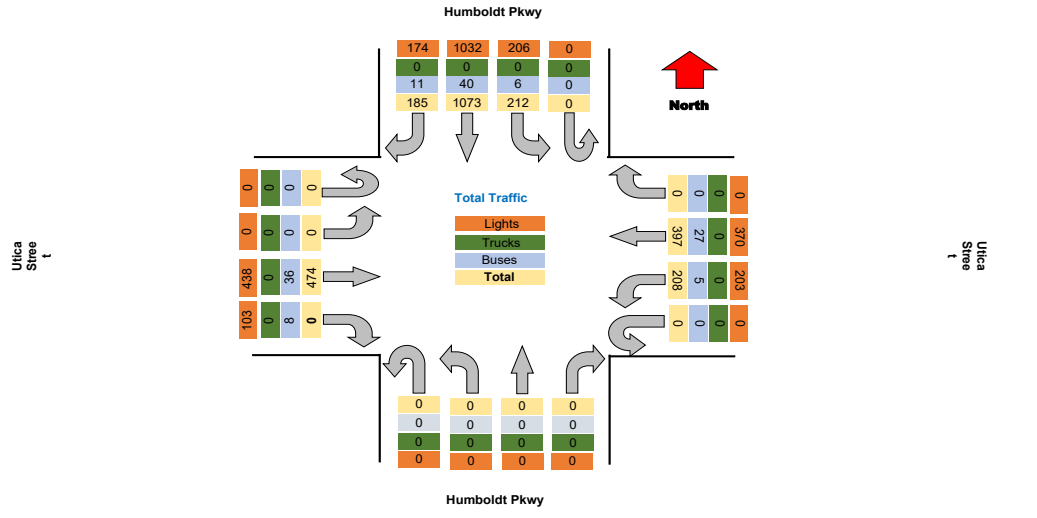

**Turning Movement Peak Hour Data (AM)**

7:30:00 AM

Leg Direction	Humboldt Pkwy					Utica Street					Humboldt Pkwy					Utica Street					Total						
	Southbound		Westbound			Northbound		Eastbound																			
Start Time	Right	Thru	Left	U-Turn	App Total	Peds CW	Peds CCW	Right	Thru	Left	U-Turn	App Total	Peds CW	Peds CCW	Right	Thru	Left	U-Turn	App Total	Peds CW	Peds CCW						
7:30:00 AM	11	71	16	0	98	0	0	0	22	9	0	31	0	0	0	0	0	0	0	8	18	0	26	0	0	155	
7:45:00 AM	12	80	6	0	98	2	1	0	21	22	0	44	0	0	0	0	0	0	0	7	20	0	27	2	1	169	
8:00:00 AM	16	73	10	0	99	1	0	0	24	10	0	34	0	0	0	0	0	0	0	6	24	0	30	1	0	163	
8:15:00 AM	13	77	15	0	105	0	0	0	33	17	0	50	0	0	0	0	0	0	0	5	22	0	27	0	0	182	
<b>Grand Total</b>	<b>52</b>	<b>301</b>	<b>47</b>	<b>0</b>	<b>400</b>	<b>3</b>	<b>1</b>	<b>0</b>	<b>100</b>	<b>56</b>	<b>0</b>	<b>159</b>	<b>0</b>	<b>0</b>	<b>0</b>	<b>0</b>	<b>0</b>	<b>0</b>	<b>0</b>	<b>25</b>	<b>84</b>	<b>0</b>	<b>110</b>	<b>3</b>	<b>1</b>	<b>669</b>	
% Approach	13.0%	75.3%	11.8%	0.0%	0.0%	0.0%	0.0%	14.2%	85.8%	0.0%	0.0%	0.0%	0.0%	0.0%	45.1%	41.7%	13.2%	0.0%	0.0%	0.0%	66.2%	33.8%	0.0%	0.0%	0.0%	0.0%	
% Total	7.8%	45.0%	7.0%	0.0%	58.8%	0.0%	0.0%	0.0%	14.9%	8.7%	0.0%	23.8%	0.0%	0.0%	0.0%	0.0%	0.0%	0.0%	0.0%	3.9%	12.6%	0.0%	0.0%	16.4%	0.0%	0.0%	
PHF	0.813	0.941	0.734	0.000	0.952	0.000	0.000	0.000	0.758	0.659	0.000	0.795	0.000	0.000	0.000	0.000	0.000	0.000	0.000	0.813	0.875	0.000	0.000	0.917	0.000	0.000	0.919
Lights	48	287	45	0	380	0	0	0	92	55	0	147	0	0	0	0	0	0	0	23	74	0	97	0	0	624	
% Trucks	0.0%	0.0%	0.0%	0.0%	0.0%	0.0%	0.0%	0.0%	0.0%	0.0%	0.0%	0.0%	0.0%	0.0%	0.0%	0.0%	0.0%	0.0%	0.0%	0.0%	0.0%	0.0%	0.0%	0.0%	0.0%	0.0%	
Buses	4	14	2	0	20	0	0	0	8	3	0	11	0	0	0	0	0	0	0	3	10	0	13	0	0	44	
% Buses	7.7%	4.7%	4.3%	0.0%	0.0%	0.0%	0.0%	0.0%	8.0%	5.2%	0.0%	0.0%	0.0%	0.0%	0.0%	0.0%	0.0%	0.0%	0.0%	11.5%	11.8%	0.0%	0.0%	0.0%	0.0%	6.8%	
Pedestrians	0	0	0	0	0	3	1	0	0	0	0	0	0	0	3	3	0	0	0	0	0	0	0	3	1	0	
% Pedestrians	0.0%	0.0%	0.0%	0.0%	0.0%	100.0%	100.0%	0.0%	0.0%	0.0%	0.0%	0.0%	0.0%	0.0%	0.0%	100.0%	100.0%	0.0%	0.0%	0.0%	0.0%	0.0%	0.0%	0.0%	100.0%	100.0%	0.0%
Bicycles on Crosswalk	0	0	0	0	0	0	0	0	0	0	0	0	0	0	0	0	0	0	0	0	0	0	0	0	0	0	
% Bicycles on Crosswalk	0.0%	0.0%	0.0%	0.0%	0.0%	0.0%	0.0%	0.0%	0.0%	0.0%	0.0%	0.0%	0.0%	0.0%	0.0%	0.0%	0.0%	0.0%	0.0%	0.0%	0.0%	0.0%	0.0%	0.0%	0.0%	0.0%	

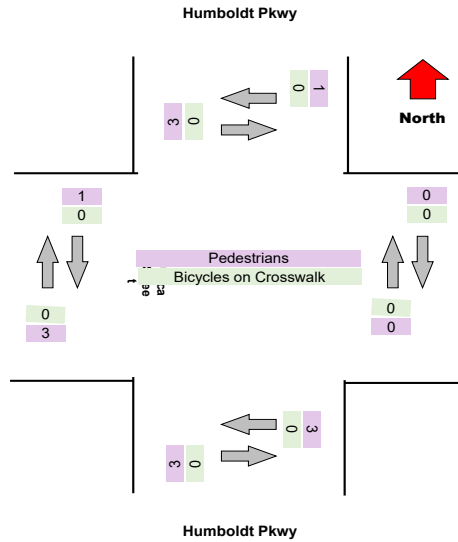
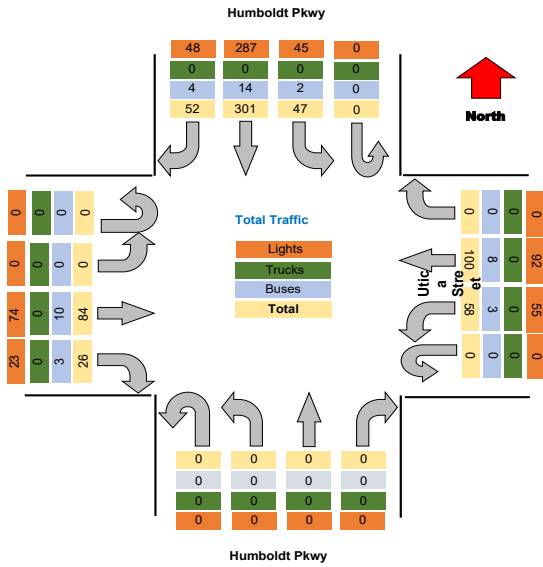

**Turning Movement Peak Hour Data (PM)**

4:15:00 PM

Leg Direction	Humboldt Pkwy				Utica Street				Humboldt Pkwy				Utica Street				Total						
	Southbound		Northbound		Westbound		Eastbound		Northbound		Southbound		Westbound		Eastbound								
Start Time	Right	Thru	Left	U-Turn	App Total	Peds CW	Peds CCW	Right	Thru	Left	U-Turn	App Total	Peds CW	Peds CCW	Right	Thru	Left	U-Turn	App Total	Peds CW	Peds CCW		
4:15:00 PM	17	90	11	0	118	1	0	0	33	15	0	48	0	0	0	0	0	0	0	0	0	0	223
4:30:00 PM	11	96	15	0	122	1	1	0	29	18	0	47	0	0	0	0	0	0	0	3	0	0	220
4:45:00 PM	10	64	18	0	92	2	2	0	40	14	0	54	2	0	0	0	0	0	2	0	0	0	199
5:00:00 PM	13	60	18	0	111	0	0	0	30	20	0	50	0	0	0	0	0	0	0	2	0	0	205
<b>Grand Total</b>	<b>51</b>	<b>339</b>	<b>62</b>	<b>0</b>	<b>443</b>	<b>4</b>	<b>3</b>	<b>0</b>	<b>132</b>	<b>67</b>	<b>0</b>	<b>199</b>	<b>2</b>	<b>0</b>	<b>0</b>	<b>0</b>	<b>0</b>	<b>0</b>	<b>2</b>	<b>3</b>	<b>0</b>	<b>0</b>	<b>847</b>
<b>% Approach</b>	11.5%	74.5%	14.0%	0.0%	0.0%	0.0%	0.0%	14.2%	85.8%	0.0%	0.0%	0.0%	0.0%	0.0%	45.1%	41.7%	13.2%	0.0%	0.0%	0.0%	0.0%	0.0%	0.0%
<b>% Total</b>	6.0%	39.0%	7.3%	0.0%	52.3%	0.0%	0.0%	0.0%	15.6%	7.3%	0.0%	23.5%	0.0%	0.0%	0.0%	0.0%	0.0%	0.0%	0.0%	0.0%	0.0%	0.0%	0.0%
<b>PHF</b>	0.750	0.859	0.861	0.000	0.908	0.000	0.000	0.000	0.825	0.838	0.000	0.921	0.000	0.000	0.000	0.000	0.000	0.000	0.000	0.000	0.000	0.000	0.950
<b>Lights</b>	49	319	61	0	429	0	0	0	126	66	0	192	0	0	0	0	0	0	0	0	0	0	813
<b>% Lights</b>	96.1%	96.7%	98.4%	0.0%	96.8%	0.0%	0.0%	0.0%	95.5%	98.5%	0.0%	96.5%	0.0%	0.0%	0.0%	0.0%	0.0%	0.0%	0.0%	0.0%	0.0%	0.0%	96.0%
<b>Trucks</b>	0	0	0	0	0	0	0	0	0	0	0	0	0	0	0	0	0	0	0	0	0	0	0
<b>% Trucks</b>	0.0%	0.0%	0.0%	0.0%	0.0%	0.0%	0.0%	0.0%	0.0%	0.0%	0.0%	0.0%	0.0%	0.0%	0.0%	0.0%	0.0%	0.0%	0.0%	0.0%	0.0%	0.0%	0.0%
<b>Buses</b>	2	10	1	0	13	0	0	0	6	1	0	7	0	0	0	0	0	0	0	0	0	0	33
<b>% Buses</b>	3.9%	3.0%	1.6%	0.0%	0.0%	0.0%	0.0%	0.0%	4.5%	1.5%	0.0%	0.0%	0.0%	0.0%	0.0%	0.0%	0.0%	0.0%	0.0%	0.0%	0.0%	0.0%	3.9%
<b>Pedestrians</b>	0	0	0	0	0	4	3	0	0	0	0	0	2	0	0	0	0	0	0	0	0	0	1
<b>% Pedestrians</b>	0.0%	0.0%	0.0%	0.0%	0.0%	100.0%	100.0%	0.0%	0.0%	0.0%	0.0%	0.0%	100.0%	100.0%	0.0%	0.0%	0.0%	0.0%	0.0%	0.0%	0.0%	0.0%	100.0%
<b>Bicycles on Crosswalk</b>	0	0	0	0	0	0	0	0	0	0	0	0	0	0	0	0	0	0	0	0	0	0	0
<b>% Bicycles on Crosswalk</b>	0.0%	0.0%	0.0%	0.0%	0.0%	0.0%	0.0%	0.0%	0.0%	0.0%	0.0%	0.0%	0.0%	0.0%	0.0%	0.0%	0.0%	0.0%	0.0%	0.0%	0.0%	0.0%	0.0%

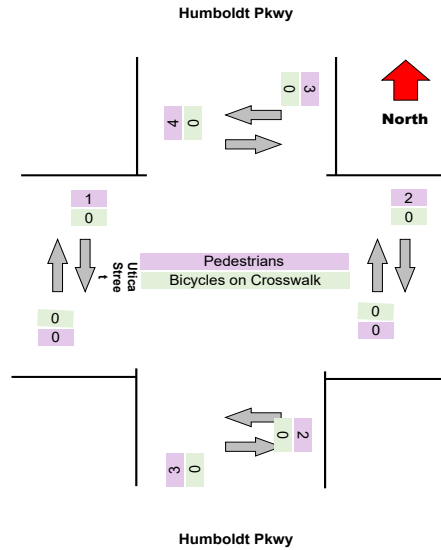
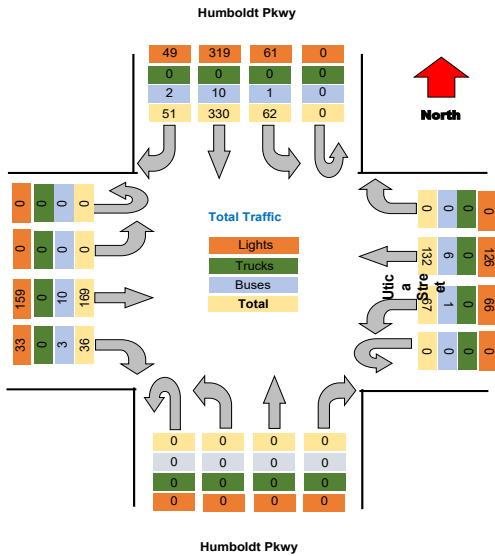



Project : VBH Malta NY  
 Site : Site 4  
 Location : 42.948550, -73.790036  
 Survey Date : 2021-04-28, Wednesday

### Turning Movement Data Plot

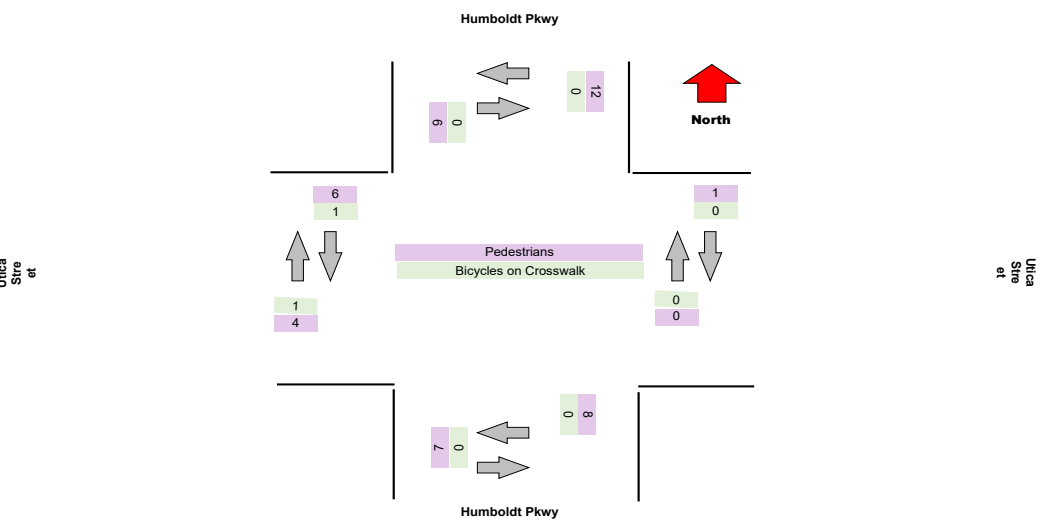
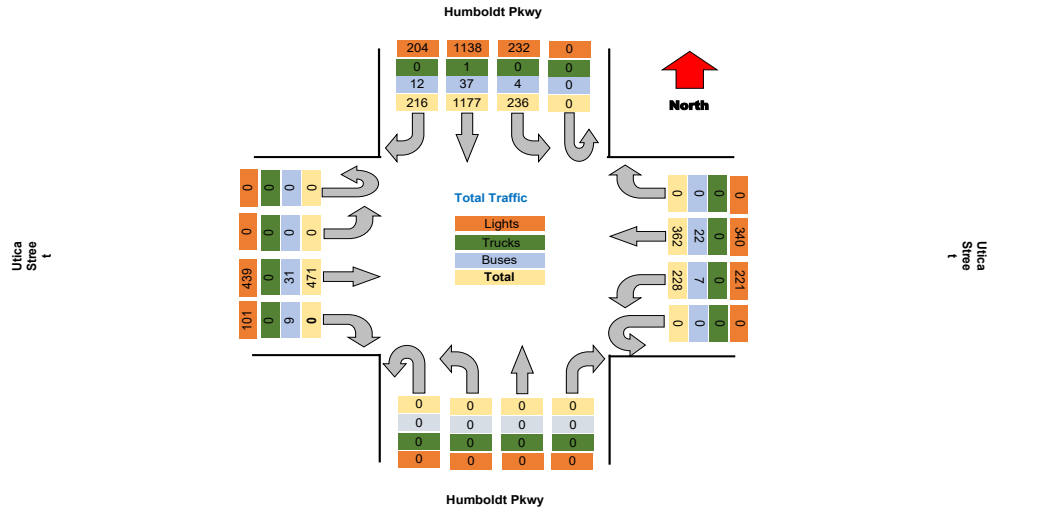

**Turning Movement Peak Hour Data (AM)**

7:30:00 AM

Leg Direction	Humboldt Pkwy					Ulica Street					Humboldt Pkwy					Ulica Street					Total	
	Southbound		Westbound			Northbound		Eastbound														
Start Time	Right	Thru	Left	U-Turn	App Total	Peds CW	Peds CCW	Right	Thru	Left	U-Turn	App Total	Peds CW	Peds CCW	Right	Thru	Left	U-Turn	App Total	Peds CW	Peds CCW	
7:30:00 AM	16	63	13	0	92	0	1	0	19	16	0	36	0	0	0	0	0	0	0	24	1	0
7:45:00 AM	18	113	13	0	144	0	0	0	31	21	0	52	0	0	0	0	0	0	34	1	2	
8:00:00 AM	13	68	12	0	93	1	0	0	24	15	0	39	0	0	0	0	0	0	20	0	0	
8:15:00 AM	10	69	10	0	109	0	0	0	25	16	0	42	0	0	0	0	0	0	31	0	0	
<b>Grand Total</b>	<b>57</b>	<b>333</b>	<b>48</b>	<b>0</b>	<b>438</b>	<b>1</b>	<b>0</b>	<b>0</b>	<b>100</b>	<b>88</b>	<b>0</b>	<b>189</b>	<b>0</b>	<b>0</b>	<b>0</b>	<b>0</b>	<b>0</b>	<b>0</b>	<b>109</b>	<b>2</b>	<b>2</b>	
% Approach	13.0%	76.0%	11.0%	0.0%	0.0%	0.0%	0.0%	14.2%	85.8%	0.0%	0.0%	0.0%	0.0%	0.0%	45.1%	41.7%	13.2%	0.0%	0.0%	0.0%	0.0%	
% Total	8.0%	46.5%	6.7%	0.0%	61.2%	0.0%	0.0%	0.0%	14.0%	9.5%	0.0%	23.6%	0.0%	0.0%	0.0%	0.0%	0.0%	0.0%	4.3%	10.9%	0.0%	
PHF	0.792	0.737	0.923	0.000	0.760	0.000	0.000	0.000	0.806	0.810	0.000	0.813	0.000	0.000	0.000	0.000	0.000	0.000	0.705	0.848	0.000	
Lights	54	319	47	0	420	0	0	0	93	64	0	157	0	0	0	0	0	0	27	71	0	
% Lights	94.7%	95.8%	97.9%	0.0%	95.9%	0.0%	0.0%	0.0%	93.0%	94.1%	0.0%	92.9%	0.0%	0.0%	0.0%	0.0%	0.0%	0.0%	87.1%	91.0%	0.0%	
Trucks	0	1	0	0	1	0	0	0	0	0	0	0	0	0	0	0	0	0	0	0	0	
% Trucks	0.0%	0.3%	0.0%	0.0%	0.2%	0.0%	0.0%	0.0%	0.0%	0.0%	0.0%	0.0%	0.0%	0.0%	0.0%	0.0%	0.0%	0.0%	0.0%	0.0%	0.0%	
Buses	3	13	1	0	17	0	0	0	7	4	0	11	0	0	0	0	0	0	4	7	0	
% Buses	5.3%	3.9%	2.1%	0.0%	0.0%	0.0%	0.0%	0.0%	7.0%	5.9%	0.0%	0.0%	0.0%	0.0%	0.0%	0.0%	0.0%	0.0%	12.9%	9.0%	0.0%	
Pedestrians	0	0	0	0	0	1	1	0	0	0	0	0	0	0	0	0	0	0	0	2	2	
% Pedestrians	0.0%	0.0%	0.0%	0.0%	0.0%	100.0%	100.0%	0.0%	0.0%	0.0%	0.0%	0.0%	0.0%	0.0%	0.0%	0.0%	0.0%	0.0%	0.0%	100.0%	100.0%	
Bicycles on Crosswalk	0	0	0	0	0	0	0	0	0	0	0	0	0	0	0	0	0	0	0	0	0	
% Bicycles on Crosswalk	0.0%	0.0%	0.0%	0.0%	0.0%	0.0%	0.0%	0.0%	0.0%	0.0%	0.0%	0.0%	0.0%	0.0%	0.0%	0.0%	0.0%	0.0%	0.0%	0.0%	0.0%	

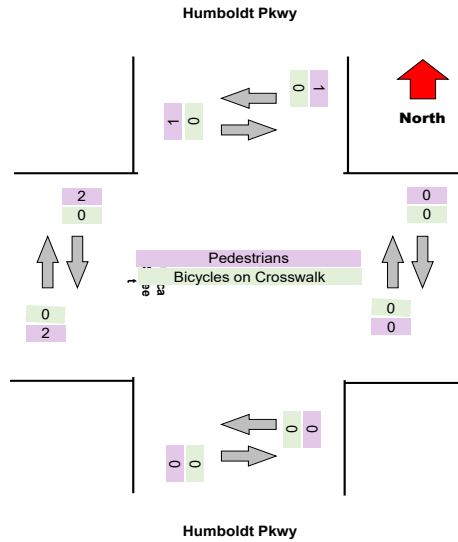
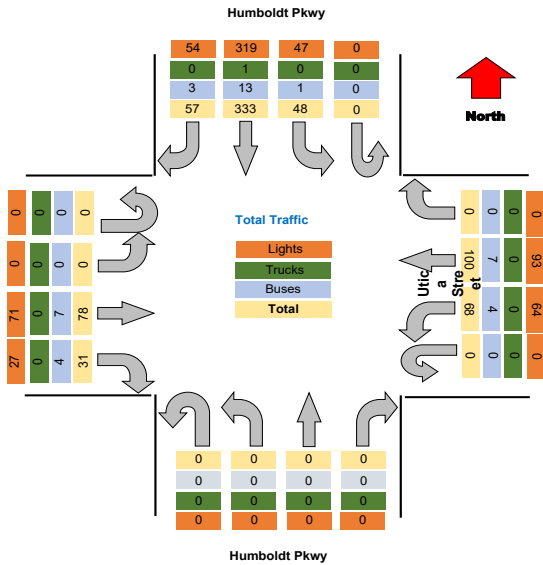



**Turning Movement Peak Hour Data (PM)**

4:15:00 PM

Leg Direction	Humboldt Pkwy					Utica Street					Humboldt Pkwy					Utica Street					Total		
	Southbound					Westbound					Northbound					Eastbound							
Start Time	Right	Thru	Left	U-Turn	App Total	Peds CW	Peds CCW	Right	Thru	Left	U-Turn	App Total	Peds CW	Peds CCW	Right	Thru	Left	U-Turn	App Total	Peds CW	Peds CCW	Total	
4:15:00 PM	19	94	25	0	138	4	0	0	23	15	0	38	0	0	0	0	0	0	0	1	0	0	230
4:30:00 PM	14	102	23	0	139	0	2	0	29	13	0	42	0	0	0	0	0	0	0	0	0	0	231
4:45:00 PM	16	87	15	0	118	1	0	0	34	9	0	43	1	0	0	0	0	0	0	4	0	0	213
5:00:00 PM	15	71	23	0	109	0	0	0	25	17	0	42	0	0	0	0	0	0	0	0	0	0	200
<b>Grand Total</b>	<b>64</b>	<b>354</b>	<b>86</b>	<b>0</b>	<b>504</b>	<b>5</b>	<b>2</b>	<b>0</b>	<b>111</b>	<b>54</b>	<b>0</b>	<b>165</b>	<b>1</b>	<b>0</b>	<b>0</b>	<b>0</b>	<b>0</b>	<b>0</b>	<b>0</b>	<b>5</b>	<b>0</b>	<b>0</b>	<b>874</b>
% Approach	12.7%	79.2%	17.1%	0.0%	0.0%	0.0%	0.0%	14.2%	85.8%	0.0%	0.0%	0.0%	0.0%	0.0%	45.1%	41.7%	13.2%	0.0%	0.0%	0.0%	0.0%	0.0%	0.0%
% Total	7.3%	40.5%	9.8%	0.0%	57.7%	0.0%	0.0%	0.0%	12.7%	6.2%	0.0%	18.9%	0.0%	0.0%	0.0%	0.0%	0.0%	0.0%	0.0%	0.0%	0.0%	0.0%	0.0%
PHF	0.842	0.868	0.860	0.000	0.906	0.000	0.000	0.000	0.816	0.794	0.000	0.959	0.000	0.000	0.000	0.000	0.000	0.000	0.000	0.833	0.911	0.000	0.946
Lights	61	342	84	0	487	0	0	0	106	53	0	159	0	0	0	0	0	0	0	0	0	0	841
% Lights	85.3%	96.6%	97.7%	0.0%	96.6%	0.0%	0.0%	0.0%	95.5%	98.1%	0.0%	96.4%	0.0%	0.0%	0.0%	0.0%	0.0%	0.0%	0.0%	0.0%	0.0%	0.0%	96.2%
Trucks	0	0	0	0	0	0	0	0	0	0	0	0	0	0	0	0	0	0	0	0	0	0	0
% Trucks	0.0%	0.0%	0.0%	0.0%	0.0%	0.0%	0.0%	0.0%	0.0%	0.0%	0.0%	0.0%	0.0%	0.0%	0.0%	0.0%	0.0%	0.0%	0.0%	0.0%	0.0%	0.0%	0.0%
Buses	3	11	2	0	16	0	0	0	5	1	0	6	0	0	0	0	0	0	0	0	0	0	31
% Buses	4.7%	3.1%	2.3%	0.0%	0.0%	0.0%	0.0%	0.0%	4.5%	1.9%	0.0%	0.0%	0.0%	0.0%	0.0%	0.0%	0.0%	0.0%	0.0%	0.0%	0.0%	0.0%	3.5%
Pedestrians	0	0	0	0	0	5	2	0	0	0	0	1	0	0	0	0	0	0	0	0	0	0	0
% Pedestrians	0.0%	0.0%	0.0%	0.0%	0.0%	100.0%	100.0%	0.0%	0.0%	0.0%	0.0%	0.0%	100.0%	0.0%	0.0%	0.0%	0.0%	0.0%	0.0%	0.0%	0.0%	0.0%	0.0%
Bicycles on Crosswalk	0	0	0	0	0	0	0	0	0	0	0	0	0	0	0	0	0	0	0	0	0	1	1
% Bicycles on Crosswalk	0.0%	0.0%	0.0%	0.0%	0.0%	0.0%	0.0%	0.0%	0.0%	0.0%	0.0%	0.0%	0.0%	0.0%	0.0%	0.0%	0.0%	0.0%	0.0%	0.0%	0.0%	50.0%	100.0%

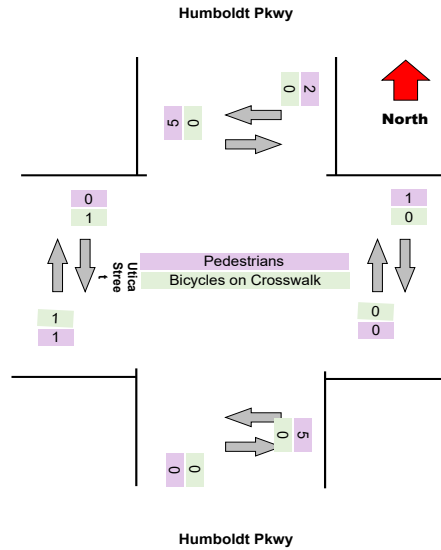
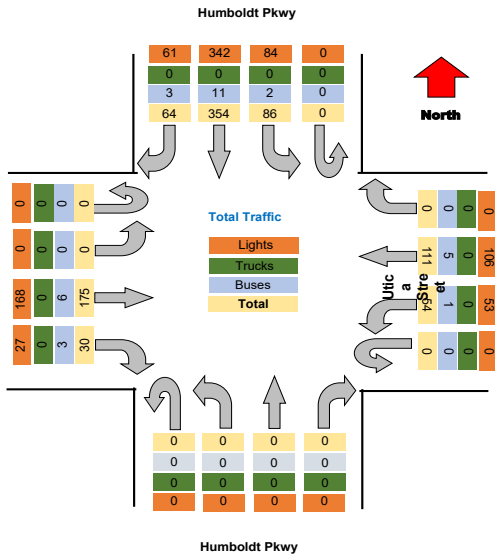



**Turning Movement Data Plot**

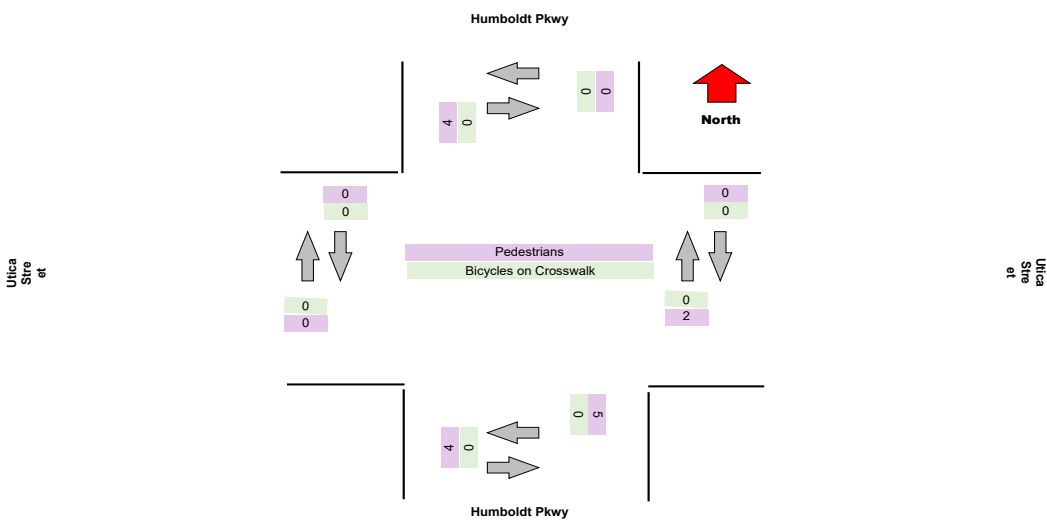
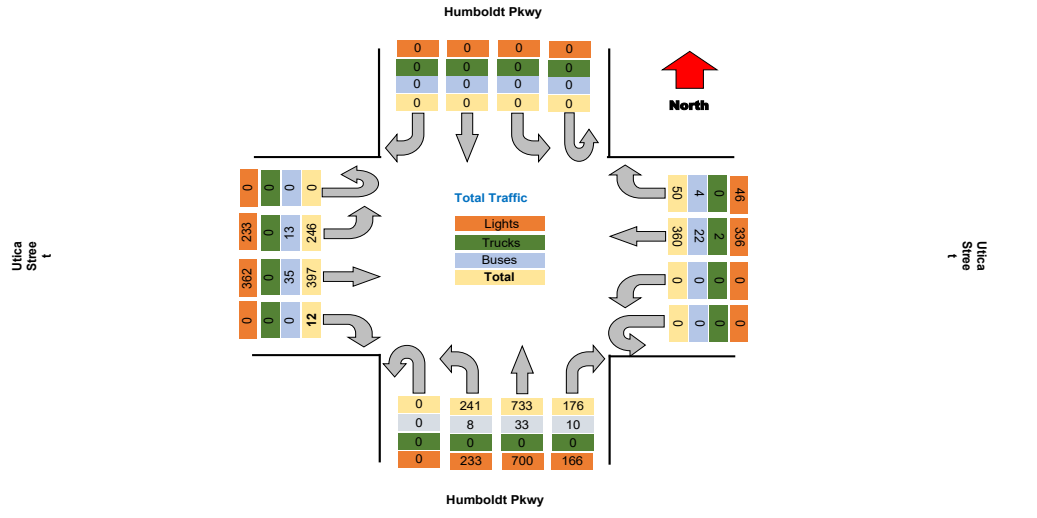

Project : VBH Malta NY  
 Site : Site 4  
 Location : 42.948550, -73.790036

TSTData.com

Survey Date : 2021-04-28, Wednesday

**Turning Movement Peak Hour Data (AM)**

7:30:00 AM

Leg Direction	Humboldt Pkwy							Ulica Street							Humboldt Pkwy							Ulica Street							Total
	Southbound				Westbound			Northbound				Eastbound			Northbound				Eastbound										
Start Time	Right	Thru	Left	U-Turn	App Total	Peds CW	Peds CCW	Right	Thru	Left	U-Turn	App Total	Peds CW	Peds CCW	Right	Thru	Left	U-Turn	App Total	Peds CW	Peds CCW	Right	Thru	Left	U-Turn	App Total	Peds CW	Peds CCW	
7:30:00 AM	0	0	0	0	0	0	0	5	19	0	0	24	0	0	12	39	14	0	65	1	0	0	17	12	0	29	0	0	
7:45:00 AM	0	0	0	0	0	0	0	2	33	0	0	35	0	0	11	52	13	0	76	0	0	0	21	13	0	34	0	0	
8:00:00 AM	0	0	0	0	0	0	0	2	29	0	0	31	0	0	12	47	15	0	74	1	0	0	22	15	0	37	0	0	
8:15:00 AM	0	0	0	0	0	0	0	5	29	0	0	25	0	1	3	57	16	0	77	0	1	0	21	12	0	33	0	0	
<b>Grand Total</b>	0	0	0	0	0	0	0	14	101	0	0	115	0	1	38	195	58	0	292	2	1	0	81	52	0	133	0	0	
% Approach	#DIV/0!	#DIV/0!	#DIV/0!	#DIV/0!	0.0%	0.0%	0.0%	14.2%	85.8%	0.0%	0.0%	0.0%	0.0%	0.0%	45.1%	41.7%	13.2%	0.0%	0.0%	0.0%	0.0%	0.0%	66.2%	33.8%	0.0%	0.0%	0.0%	0.0%	
% Total	0.0%	0.0%	0.0%	0.0%	0.0%	0.0%	0.0%	2.6%	18.7%	0.0%	0.0%	21.3%	0.0%	0.0%	7.0%	36.1%	10.7%	0.0%	54.1%	0.0%	0.0%	0.0%	15.0%	9.6%	0.0%	24.6%	0.0%	0.0%	
PHF	0.000	0.000	0.000	0.000	0.000	0.000	0.000	0.700	0.785	0.000	0.000	0.821	0.000	0.000	0.792	0.855	0.906	0.000	0.848	0.000	0.000	0.000	0.920	0.867	0.000	0.899	0.000	0.000	
Lights	0	0	0	0	0	0	0	11	94	0	0	105	0	0	35	184	55	0	274	0	0	0	71	49	0	120	0	0	
% Lights	0.0%	0.0%	0.0%	0.0%	0.0%	0.0%	0.0%	78.6%	93.1%	0.0%	0.0%	91.3%	0.0%	0.0%	82.1%	94.4%	94.8%	0.0%	93.8%	0.0%	0.0%	0.0%	87.7%	94.2%	0.0%	90.2%	0.0%	0.0%	
Trucks	0	0	0	0	0	0	0	0	0	0	0	0	0	0	0	0	0	0	0	0	0	0	0	0	0	0	0	0	
% Trucks	0.0%	0.0%	0.0%	0.0%	0.0%	0.0%	0.0%	0.0%	0.0%	0.0%	0.0%	0.0%	0.0%	0.0%	0.0%	0.0%	0.0%	0.0%	0.0%	0.0%	0.0%	0.0%	0.0%	0.0%	0.0%	0.0%	0.0%	0.0%	
Buses	0	0	0	0	0	0	0	3	7	0	0	10	0	0	3	11	3	0	17	0	0	0	10	3	0	13	0	0	
% Buses	0.0%	0.0%	0.0%	0.0%	0.0%	0.0%	0.0%	21.4%	6.9%	0.0%	0.0%	0.0%	0.0%	0.0%	7.9%	5.6%	5.2%	0.0%	0.0%	0.0%	0.0%	0.0%	12.3%	5.8%	0.0%	0.0%	0.0%	0.0%	
Pedestrians	0	0	0	0	0	0	0	0	0	0	0	0	1	0	0	0	0	0	2	1	0	0	0	0	0	0	0	0	
% Pedestrians	0.0%	0.0%	0.0%	0.0%	0.0%	0.0%	0.0%	0.0%	0.0%	0.0%	0.0%	0.0%	100.0%	0.0%	0.0%	0.0%	0.0%	0.0%	0.0%	100.0%	100.0%	0.0%	0.0%	0.0%	0.0%	0.0%	0.0%	0.0%	
Bicycles on Crosswalk	0	0	0	0	0	0	0	0	0	0	0	0	0	0	0	0	0	0	0	0	0	0	0	0	0	0	0	0	
% Bicycles on Crosswalk	0.0%	0.0%	0.0%	0.0%	0.0%	0.0%	0.0%	0.0%	0.0%	0.0%	0.0%	0.0%	0.0%	0.0%	0.0%	0.0%	0.0%	0.0%	0.0%	0.0%	0.0%	0.0%	0.0%	0.0%	0.0%	0.0%	0.0%	0.0%	

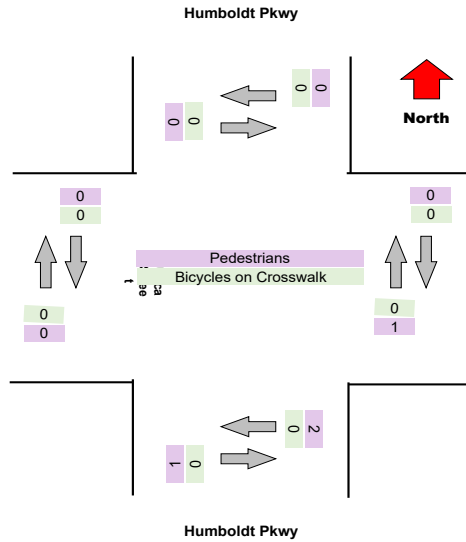
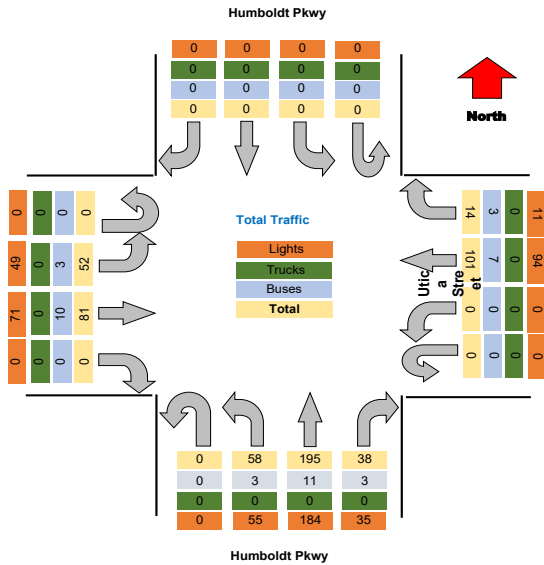

**Turning Movement Peak Hour Data (PM)**

4:15:00 PM

Leg Direction	Humboldt Pkwy						Ulica Street						Humboldt Pkwy						Ulica Street						Total
	Southbound			Westbound			Northbound			Eastbound															
Start Time	Right	Thru	Left	U-Turn	App Total	Peds CW	Peds CCW	Right	Thru	Left	U-Turn	App Total	Peds CW	Peds CCW	Right	Thru	Left	U-Turn	App Total	Peds CW	Peds CCW	Total			
4:15:00 PM	0	0	0	0	0	0	0	5	24	0	0	29	0	0	13	54	17	0	84	0	0	48	0	0	
4:30:00 PM	0	0	0	0	0	0	0	4	19	0	0	23	0	0	21	45	11	0	77	1	0	62	0	0	
4:45:00 PM	0	0	0	0	0	0	0	6	20	0	0	26	0	0	17	62	20	0	99	0	0	49	0	0	
5:00:00 PM	0	0	0	0	0	0	0	6	26	0	0	32	0	0	8	54	24	0	86	0	0	31	0	0	
Grand Total	0	0	0	0	0	0	0	21	89	0	0	110	0	0	59	215	72	0	346	1	0	143	0	0	
% Approach	#DIV/0!	#DIV/0!	#DIV/0!	#DIV/0!	0.0%	0.0%	0.0%	14.2%	85.8%	0.0%	0.0%	0.0%	0.0%	0.0%	45.1%	41.7%	13.2%	0.0%	0.0%	0.0%	0.0%	0.0%	0.0%	0.0%	
% Total	0.0%	0.0%	0.0%	0.0%	0.0%	0.0%	0.0%	3.2%	13.4%	0.0%	0.0%	16.6%	0.0%	0.0%	8.9%	32.4%	10.8%	0.0%	52.1%	0.0%	0.0%	0.0%	0.0%	0.0%	
PHF	0.000	0.000	0.000	0.000	0.000	0.000	0.000	0.875	0.856	0.000	0.000	0.859	0.000	0.000	0.702	0.867	0.750	0.000	0.874	0.000	0.000	0.000	0.000	0.954	
Lights	0	0	0	0	0	0	0	20	84	0	0	104	0	0	56	203	71	0	330	0	0	198	0	0	
% Lights	0.0%	0.0%	0.0%	0.0%	0.0%	0.0%	0.0%	85.2%	94.4%	0.0%	0.0%	94.5%	0.0%	0.0%	84.9%	94.4%	98.6%	0.0%	95.4%	0.0%	0.0%	95.2%	0.0%	0.0%	
Trucks	0	0	0	0	0	0	0	0	0	0	0	0	0	0	0	0	0	0	0	0	0	0	0	0	
% Trucks	0.0%	0.0%	0.0%	0.0%	0.0%	0.0%	0.0%	0.0%	0.0%	0.0%	0.0%	0.0%	0.0%	0.0%	0.0%	0.0%	0.0%	0.0%	0.0%	0.0%	0.0%	0.0%	0.0%	0.0%	
Buses	0	0	0	0	0	0	0	1	5	0	0	6	0	0	3	12	1	0	16	0	0	10	0	0	
% Buses	0.0%	0.0%	0.0%	0.0%	0.0%	0.0%	0.0%	4.8%	5.6%	0.0%	0.0%	0.0%	0.0%	0.0%	5.1%	5.6%	1.4%	0.0%	0.0%	0.0%	0.0%	0.0%	0.0%	4.8%	
Pedestrians	0	0	0	0	0	0	0	0	0	0	0	0	0	0	0	0	0	0	1	0	0	0	0	0	
% Pedestrians	0.0%	0.0%	0.0%	0.0%	0.0%	0.0%	0.0%	0.0%	0.0%	0.0%	0.0%	0.0%	0.0%	0.0%	0.0%	0.0%	0.0%	0.0%	0.0%	100.0%	0.0%	0.0%	0.0%	0.0%	
Bicycles on Crosswalk	0	0	0	0	0	0	0	0	0	0	0	0	0	0	0	0	0	0	0	0	0	0	0	0	
% Bicycles on Crosswalk	0.0%	0.0%	0.0%	0.0%	0.0%	0.0%	0.0%	0.0%	0.0%	0.0%	0.0%	0.0%	0.0%	0.0%	0.0%	0.0%	0.0%	0.0%	0.0%	0.0%	0.0%	0.0%	0.0%	0.0%	

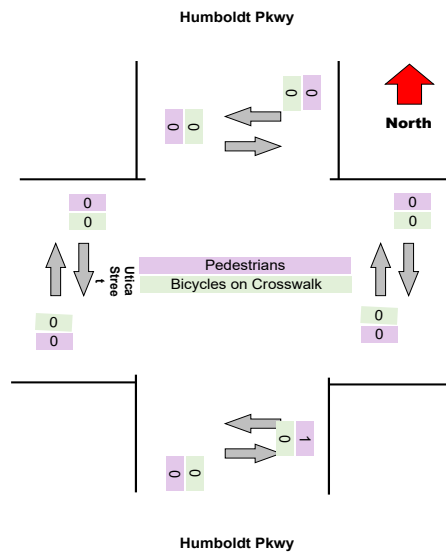
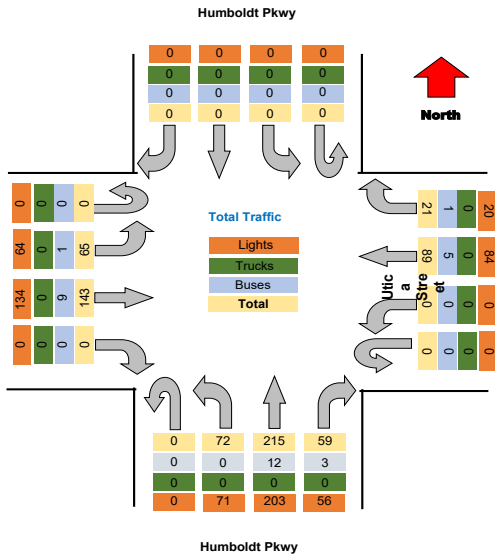



Project : VBH Malta NY  
 Site : Site 4  
 Location : 42.948550, -73.790036  
 Survey Date : 2021-04-28, Wednesday

### Turning Movement Data Plot

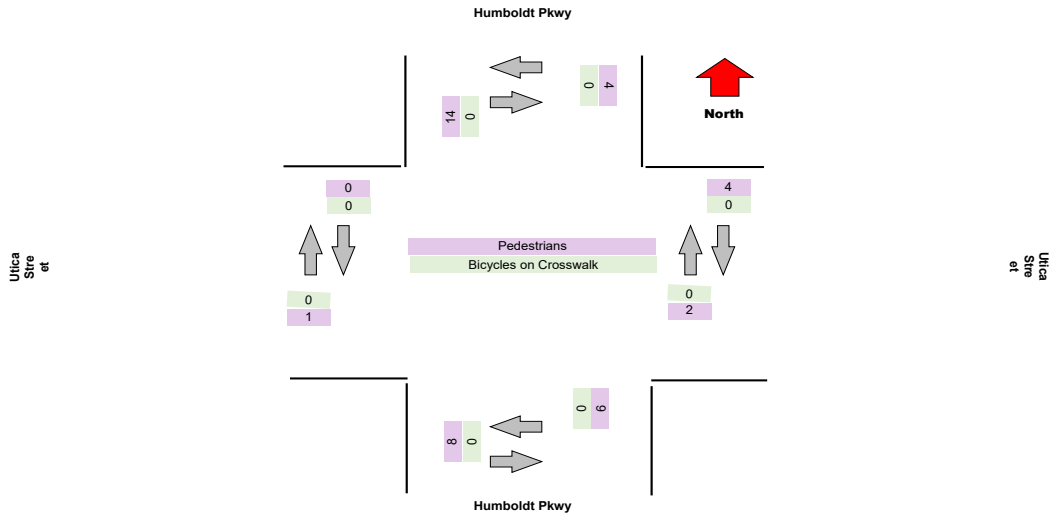
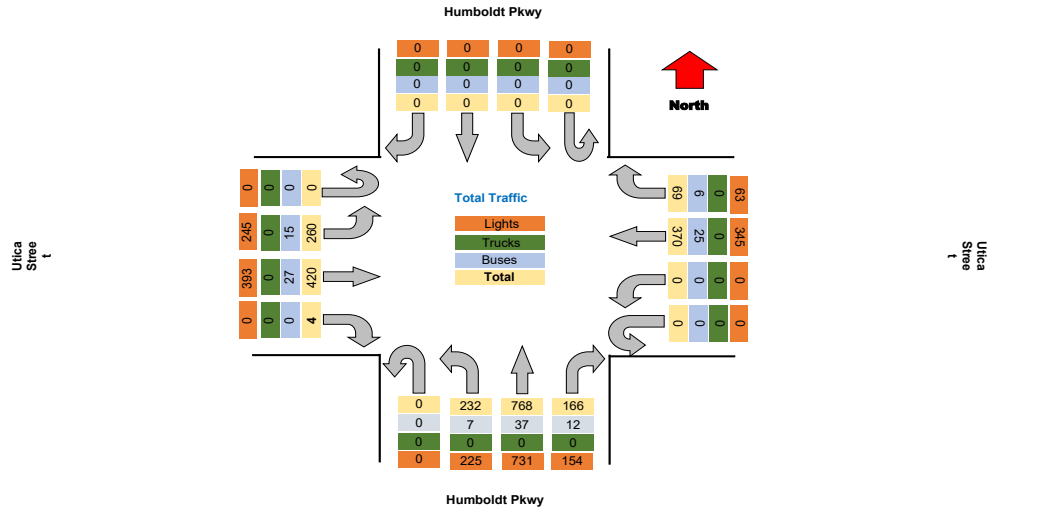

**Turning Movement Peak Hour Data (AM)**

7:30:00 AM

Leg Direction	Humboldt Pkwy								Utica Street								Humboldt Pkwy								Utica Street								Total
	Southbound				Westbound				Northbound				Eastbound																				
Start Time	Right	Thru	Left	U-Turn	App Total	Peds CW	Peds CCW	Right	Thru	Left	U-Turn	App Total	Peds CW	Peds CCW	Right	Thru	Left	U-Turn	App Total	Peds CW	Peds CCW	Right	Thru	Left	U-Turn	App Total	Peds CW	Peds CCW					
7:30:00 AM	0	0	0	0	0	0	0	1	17	0	0	18	0	0	4	44	14	0	62	0	0	0	24	8	0	32	0	0					
7:45:00 AM	0	0	0	0	0	2	1	4	28	0	0	33	0	0	10	54	12	0	76	0	2	0	17	16	0	33	0	0					
8:00:00 AM	0	0	0	0	0	0	0	3	20	0	0	23	2	0	11	64	17	0	94	2	0	0	20	15	0	35	0	0					
8:15:00 AM	0	0	0	0	0	0	0	2	27	0	0	29	0	0	7	36	18	0	61	1	1	0	21	13	0	34	0	0					
Grand Total	0	0	0	0	0	2	1	10	92	0	0	103	2	0	32	198	61	0	293	3	3	0	82	52	0	134	3	0					
% Approach	#DIV/0!	#DIV/0!	#DIV/0!	#DIV/0!	0.0%	0.0%	0.0%	14.2%	85.8%	0.0%	0.0%	0.0%	0.0%	0.0%	45.1%	41.7%	13.2%	0.0%	0.0%	0.0%	0.0%	0.0%	66.2%	33.8%	0.0%	0.0%	0.0%	0.0%					
% Total	0.0%	0.0%	0.0%	0.0%	0.0%	0.0%	0.0%	1.9%	17.4%	0.0%	0.0%	19.4%	0.0%	0.0%	6.0%	37.4%	11.5%	0.0%	55.3%	0.0%	0.0%	0.0%	15.5%	9.8%	0.0%	25.3%	0.0%	0.0%					
PHF	0.000	0.000	0.000	0.000	0.000	0.000	0.000	0.625	0.821	0.000	0.000	0.780	0.000	0.000	0.727	0.773	0.847	0.000	0.779	0.000	0.000	0.000	0.854	0.813	0.000	0.957	0.000	0.000					
Lights	0	0	0	0	0	0	0	7	84	0	0	91	0	0	29	187	58	0	274	0	0	0	73	49	0	122	0	0					
% Lights	0.0%	0.0%	0.0%	0.0%	0.0%	0.0%	0.0%	70.0%	91.3%	0.0%	0.0%	88.3%	0.0%	0.0%	80.6%	94.4%	95.1%	0.0%	93.5%	0.0%	0.0%	0.0%	89.0%	94.2%	0.0%	91.0%	0.0%	0.0%					
Trucks	0	0	0	0	0	0	0	0	0	0	0	0	0	0	0	0	0	0	0	0	0	0	0	0	0	0	0	0					
% Trucks	0.0%	0.0%	0.0%	0.0%	0.0%	0.0%	0.0%	0.0%	0.0%	0.0%	0.0%	0.0%	0.0%	0.0%	0.0%	0.0%	0.0%	0.0%	0.0%	0.0%	0.0%	0.0%	0.0%	0.0%	0.0%	0.0%	0.0%	0.0%					
Buses	0	0	0	0	0	0	0	3	8	0	0	11	0	0	3	11	3	0	17	0	0	0	9	3	0	12	0	0					
% Buses	0.0%	0.0%	0.0%	0.0%	0.0%	0.0%	0.0%	30.0%	8.7%	0.0%	0.0%	0.0%	0.0%	0.0%	9.4%	5.6%	4.9%	0.0%	0.0%	0.0%	0.0%	0.0%	11.0%	5.8%	0.0%	0.0%	0.0%	0.0%					
Pedestrians	0	0	0	0	2	1	0	0	0	0	0	2	0	0	0	0	0	0	3	3	0	0	0	0	0	0	0	0					
% Pedestrians	0.0%	0.0%	0.0%	0.0%	0.0%	100.0%	100.0%	0.0%	0.0%	0.0%	0.0%	0.0%	100.0%	0.0%	0.0%	0.0%	0.0%	0.0%	0.0%	100.0%	100.0%	0.0%	0.0%	0.0%	0.0%	0.0%	0.0%	0.0%					
Bicycles on Crosswalk	0	0	0	0	0	0	0	0	0	0	0	0	0	0	0	0	0	0	0	0	0	0	0	0	0	0	0	0					
% Bicycles on Crosswalk	0.0%	0.0%	0.0%	0.0%	0.0%	0.0%	0.0%	0.0%	0.0%	0.0%	0.0%	0.0%	0.0%	0.0%	0.0%	0.0%	0.0%	0.0%	0.0%	0.0%	0.0%	0.0%	0.0%	0.0%	0.0%	0.0%	0.0%	0.0%					

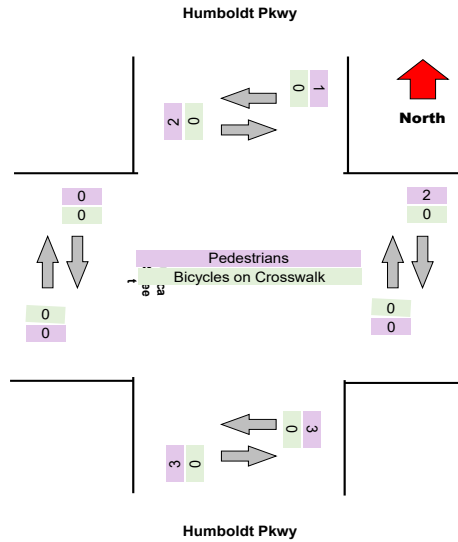
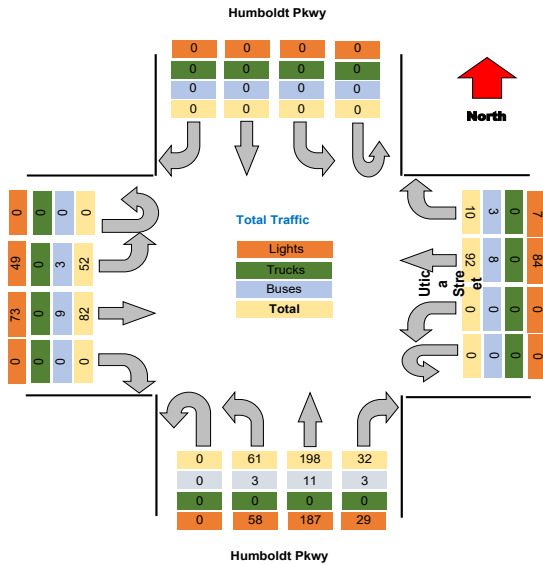



Project : VBH Malta NY  
 Site : Site 4  
 Location : 42.948550, -73.790036

TSTData.com

Survey Date : 2021-04-28, Wednesday

**Turning Movement Peak Hour Data (PM)**

4:15:00 PM

Leg Direction	Humboldt Pkwy						Utica Street						Humboldt Pkwy						Utica Street						Total				
	Southbound			Westbound			Northbound			Eastbound																			
Start Time	Right	Thru	Left	U-Turn	App Total	Peds CW	Peds CCW	Right	Thru	Left	U-Turn	App Total	Peds CW	Peds CCW	Right	Thru	Left	U-Turn	App Total	Peds CW	Peds CCW	Right	Thru	Left	U-Turn	App Total	Peds CW	Peds CCW	
4:15:00 PM	0	0	0	0	0	0	0	6	26	0	0	32	0	0	19	71	24	0	114	0	0	0	39	17	0	56	0	0	202
4:30:00 PM	0	0	0	0	0	1	0	11	33	0	0	44	0	0	18	56	12	0	86	1	1	0	40	25	0	65	1	0	196
4:45:00 PM	0	0	0	0	0	2	2	5	36	0	0	41	0	0	14	48	21	0	83	0	2	0	46	19	0	65	0	0	189
5:00:00 PM	0	0	0	0	0	0	0	6	27	0	0	33	0	0	11	47	16	0	74	0	0	0	31	17	0	48	0	0	155
Grand Total	0	0	0	0	0	3	2	28	122	0	0	150	0	0	62	222	73	0	357	1	3	0	156	79	0	234	1	0	741
% Approach	#DIV/0!	#DIV/0!	#DIV/0!	#DIV/0!	0.0%	0.0%	0.0%	14.2%	85.8%	0.0%	0.0%	0.0%	0.0%	0.0%	45.1%	41.7%	13.2%	0.0%	0.0%	0.0%	0.0%	0.0%	66.2%	33.8%	0.0%	0.0%	0.0%	0.0%	
% Total	0.0%	0.0%	0.0%	0.0%	0.0%	0.0%	0.0%	3.8%	16.5%	0.0%	0.0%	20.2%	0.0%	0.0%	8.4%	30.0%	9.9%	0.0%	48.2%	0.0%	0.0%	0.0%	21.1%	10.5%	0.0%	31.6%	0.0%	0.0%	
PHF	0.000	0.000	0.000	0.000	0.000	0.000	0.000	0.636	0.847	0.000	0.000	0.852	0.000	0.000	0.816	0.782	0.760	0.000	0.783	0.000	0.000	0.000	0.848	0.780	0.000	0.900	0.000	0.000	0.917
Lights	0	0	0	0	0	0	0	27	116	0	0	143	0	0	57	207	72	0	336	0	0	0	148	75	0	223	0	0	702
% Lights	0.0%	0.0%	0.0%	0.0%	0.0%	0.0%	0.0%	96.4%	95.1%	0.0%	0.0%	95.3%	0.0%	0.0%	91.9%	93.2%	98.6%	0.0%	94.1%	0.0%	0.0%	0.0%	94.9%	96.2%	0.0%	95.3%	0.0%	0.0%	94.7%
Trucks	0	0	0	0	0	0	0	0	0	0	0	0	0	0	0	0	0	0	0	0	0	0	0	0	0	0	0	0	0
% Trucks	0.0%	0.0%	0.0%	0.0%	0.0%	0.0%	0.0%	0.0%	0.0%	0.0%	0.0%	0.0%	0.0%	0.0%	0.0%	0.0%	0.0%	0.0%	0.0%	0.0%	0.0%	0.0%	0.0%	0.0%	0.0%	0.0%	0.0%	0.0%	0.0%
Buses	0	0	0	0	0	0	0	1	6	0	0	7	0	0	5	15	1	0	21	0	0	0	8	3	0	11	0	0	39
% Buses	0.0%	0.0%	0.0%	0.0%	0.0%	0.0%	0.0%	3.6%	4.9%	0.0%	0.0%	0.0%	0.0%	0.0%	8.1%	6.8%	1.4%	0.0%	0.0%	0.0%	0.0%	0.0%	5.1%	3.8%	0.0%	0.0%	0.0%	0.0%	5.3%
Pedestrians	0	0	0	0	4	2	0	0	0	0	0	0	0	0	0	0	0	0	1	3	0	0	0	0	0	0	1	0	0
% Pedestrians	0.0%	0.0%	0.0%	0.0%	100.0%	100.0%	0.0%	0.0%	0.0%	0.0%	0.0%	0.0%	0.0%	0.0%	0.0%	0.0%	0.0%	0.0%	0.0%	100.0%	100.0%	0.0%	0.0%	0.0%	0.0%	0.0%	100.0%	0.0%	0.0%
Bicycles on Crosswalk	0	0	0	0	0	0	0	0	0	0	0	0	0	0	0	0	0	0	0	0	0	0	0	0	0	0	0	0	0
% Bicycles on Crosswalk	0.0%	0.0%	0.0%	0.0%	0.0%	0.0%	0.0%	0.0%	0.0%	0.0%	0.0%	0.0%	0.0%	0.0%	0.0%	0.0%	0.0%	0.0%	0.0%	0.0%	0.0%	0.0%	0.0%	0.0%	0.0%	0.0%	0.0%	0.0%	0.0%

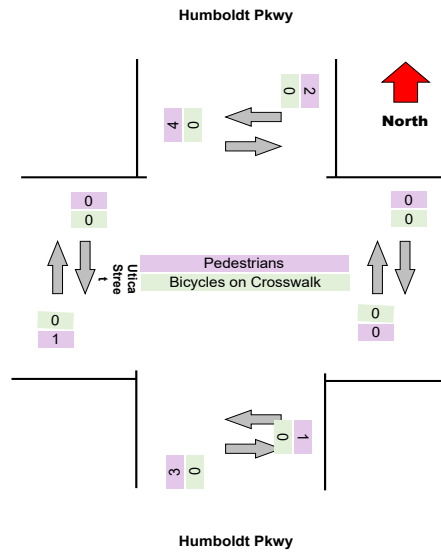
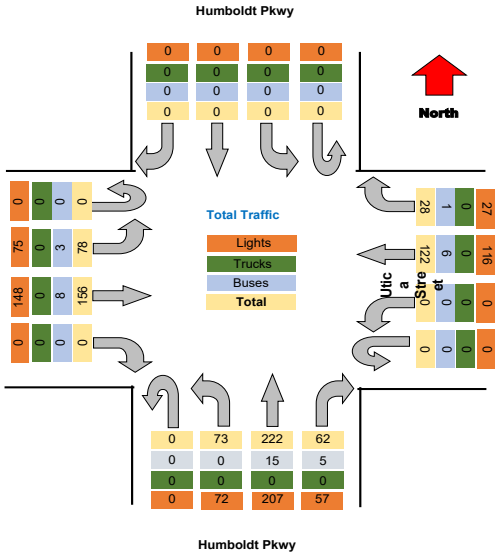



### Turning Movement Data Plot

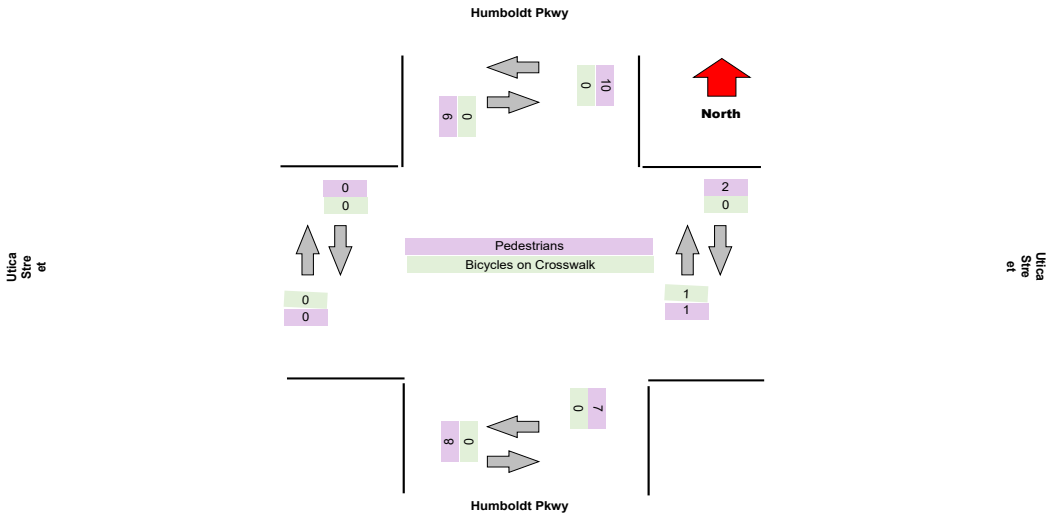
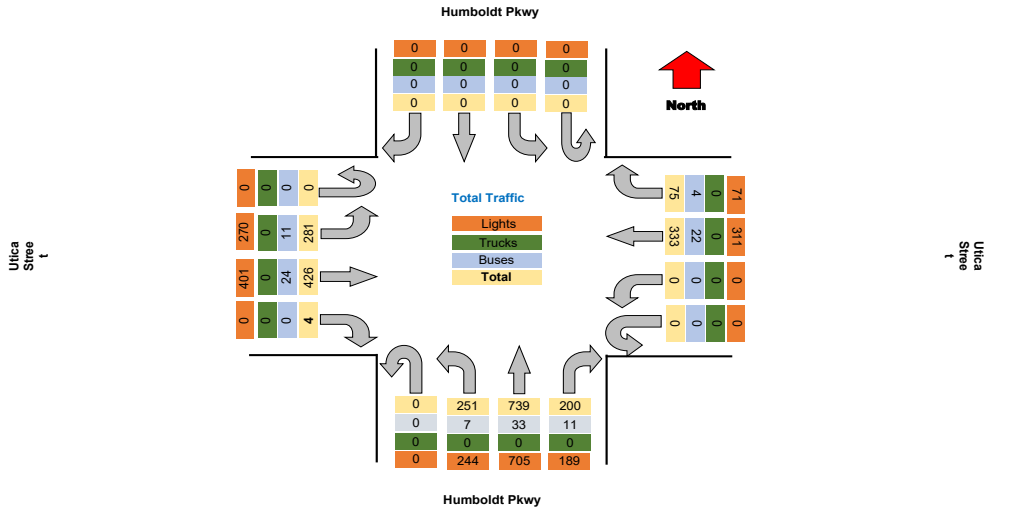

Project : VBH Malta NY  
Site : Site 4  
Location : 42.948550, -73.790036

TSTData.com

Survey Date : 2021-04-28, Wednesday

### Turning Movement Peak Hour Data (AM)

7:30:00 AM

Leg Direction	Humboldt Pkwy							Utica Street							Humboldt Pkwy							Utica Street							Total
	Southbound			Westbound				Northbound			Eastbound				Northbound			Eastbound											
Start Time	Right	Thru	Left	U-Turn	App Total	Peds CW	Peds CCW	Right	Thru	Left	U-Turn	App Total	Peds CW	Peds CCW	Right	Thru	Left	U-Turn	App Total	Peds CW	Peds CCW	Right	Thru	Left	U-Turn	App Total	Peds CW	Peds CCW	
7:30:00 AM	0	0	0	0	0	0	0	5	22	0	0	27	0	0	4	33	14	0	51	0	0	0	15	16	0	31	0	0	
7:45:00 AM	0	0	0	0	0	0	1	4	33	0	0	38	0	0	14	62	19	0	95	0	0	0	23	8	0	31	0	0	
8:00:00 AM	0	0	0	0	0	1	0	5	22	0	0	27	0	0	20	60	17	0	97	0	0	0	20	15	0	35	0	0	
8:15:00 AM	0	0	0	0	0	0	0	2	21	0	0	23	0	0	10	44	19	0	73	0	0	0	23	8	0	31	0	0	
Grand Total	0	0	0	0	1	0	0	16	98	0	0	115	0	0	48	199	69	0	316	0	0	0	81	47	0	128	0	0	
% Approach	#DIV/0!	#DIV/0!	#DIV/0!	#DIV/0!	0.0%	0.0%	0.0%	14.2%	85.8%	0.0%	0.0%	0.0%	0.0%	0.0%	45.1%	41.7%	13.2%	0.0%	0.0%	0.0%	0.0%	0.0%	66.2%	33.8%	0.0%	0.0%	0.0%	0.0%	
% Total	0.0%	0.0%	0.0%	0.0%	0.0%	0.0%	0.0%	2.9%	17.5%	0.0%	0.0%	20.6%	0.0%	0.0%	8.6%	35.6%	12.3%	0.0%	56.5%	0.0%	0.0%	0.0%	14.5%	8.4%	0.0%	22.9%	0.0%	0.0%	
PHF	0.000	0.000	0.000	0.000	0.000	0.000	0.000	0.800	0.742	0.000	0.000	0.757	0.000	0.000	0.600	0.802	0.908	0.000	0.814	0.000	0.000	0.000	0.880	0.734	0.000	0.914	0.000	0.000	
Lights	0	0	0	0	0	0	0	13	90	0	0	103	0	0	45	187	66	0	298	0	0	0	75	45	0	120	0	0	
% Lights	0.0%	0.0%	0.0%	0.0%	0.0%	0.0%	0.0%	81.3%	91.8%	0.0%	0.0%	89.6%	0.0%	0.0%	93.8%	94.0%	95.7%	0.0%	94.3%	0.0%	0.0%	0.0%	92.6%	95.7%	0.0%	93.8%	0.0%	0.0%	
Trucks	0	0	0	0	0	0	0	0	0	0	0	0	0	0	0	0	0	0	0	0	0	0	0	0	0	0	0	0	
% Trucks	0.0%	0.0%	0.0%	0.0%	0.0%	0.0%	0.0%	0.0%	0.0%	0.0%	0.0%	0.0%	0.0%	0.0%	0.0%	0.0%	0.0%	0.0%	0.0%	0.0%	0.0%	0.0%	0.0%	0.0%	0.0%	0.0%	0.0%	0.0%	
Buses	0	0	0	0	0	0	0	3	8	0	0	11	0	0	3	12	3	0	18	0	0	0	6	2	0	8	0	0	
% Buses	0.0%	0.0%	0.0%	0.0%	0.0%	0.0%	0.0%	18.8%	8.2%	0.0%	0.0%	0.0%	0.0%	0.0%	6.3%	6.0%	4.3%	0.0%	0.0%	0.0%	0.0%	0.0%	7.4%	4.3%	0.0%	0.0%	0.0%	6.8%	
Pedestrians	0	0	0	0	0	1	1	0	0	0	0	0	0	0	0	0	0	0	0	0	0	0	0	0	0	0	0	0	
% Pedestrians	0.0%	0.0%	0.0%	0.0%	0.0%	100.0%	100.0%	0.0%	0.0%	0.0%	0.0%	0.0%	0.0%	0.0%	0.0%	0.0%	0.0%	0.0%	0.0%	0.0%	0.0%	0.0%	0.0%	0.0%	0.0%	0.0%	0.0%	0.0%	
Bicycles on Crosswalk	0	0	0	0	0	0	0	0	0	0	0	0	0	0	0	0	0	0	0	0	0	0	0	0	0	0	0	0	
% Bicycles on Crosswalk	0.0%	0.0%	0.0%	0.0%	0.0%	0.0%	0.0%	0.0%	0.0%	0.0%	0.0%	0.0%	0.0%	0.0%	0.0%	0.0%	0.0%	0.0%	0.0%	0.0%	0.0%	0.0%	0.0%	0.0%	0.0%	0.0%	0.0%	0.0%	

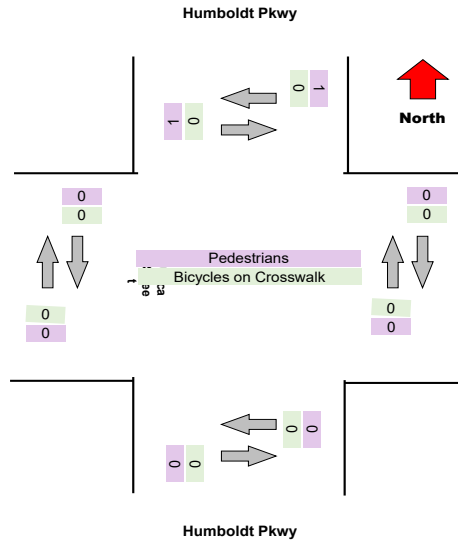
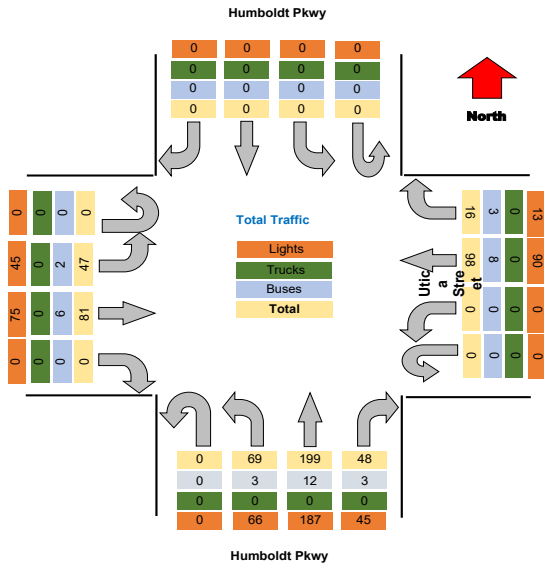

Project : VBH Malta NY  
Site : Site 4  
Location : 42.948550, -73.790036

TSTData.com

Survey Date : 2021-04-28, Wednesday

### Turning Movement Peak Hour Data (PM)

4:15:00 PM

Leg Direction	Humboldt Pkwy						Utica Street						Humboldt Pkwy						Utica Street						Total				
	Southbound			Northbound			Westbound			Eastbound			Northbound			Eastbound													
Start Time	Right	Thru	Left	U-Turn	App Total	Peds CW	Peds CCW	Right	Thru	Left	U-Turn	App Total	Peds CW	Peds CCW	Right	Thru	Left	U-Turn	App Total	Peds CW	Peds CCW	Right	Thru	Left	U-Turn	App Total	Peds CW	Peds CCW	
4:15:00 PM	0	0	0	0	0	0	0	6	22	0	0	28	0	0	11	67	14	0	92	1	1	0	42	34	0	76	0	0	196
4:30:00 PM	0	0	0	0	0	0	0	7	20	0	0	27	0	0	24	50	22	0	96	4	0	0	31	23	0	54	0	0	177
4:45:00 PM	0	0	0	0	0	0	0	7	27	0	0	34	0	0	12	41	16	0	69	4	0	0	40	29	0	69	0	0	172
5:00:00 PM	0	0	0	0	0	0	0	8	22	0	0	30	0	0	17	48	24	0	89	0	0	0	41	24	0	65	0	0	184
<b>Grand Total</b>	0	0	0	0	0	0	0	28	91	0	0	119	0	0	64	206	76	0	346	5	1	0	154	110	0	264	0	0	729
<b>% Approach</b>	#DIV/0!	#DIV/0!	#DIV/0!	#DIV/0!	0.0%	0.0%	0.0%	14.2%	85.8%	0.0%	0.0%	0.0%	0.0%	0.0%	45.1%	41.7%	13.2%	0.0%	0.0%	0.0%	0.0%	0.0%	66.2%	33.8%	0.0%	0.0%	0.0%	0.0%	0.0%
<b>% Total</b>	0.0%	0.0%	0.0%	0.0%	0.0%	0.0%	0.0%	3.8%	12.5%	0.0%	0.0%	16.3%	0.0%	0.0%	8.8%	28.3%	10.4%	0.0%	47.5%	0.0%	0.0%	0.0%	21.1%	15.1%	0.0%	36.2%	0.0%	0.0%	0.0%
<b>PHF</b>	0.000	0.000	0.000	0.000	0.000	0.000	0.000	0.875	0.843	0.000	0.000	0.875	0.000	0.000	0.667	0.769	0.792	0.000	0.801	0.000	0.000	0.000	0.917	0.809	0.000	0.868	0.000	0.000	0.930
<b>Lights</b>	0	0	0	0	0	0	0	27	86	0	0	113	0	0	62	194	75	0	331	0	0	0	147	108	0	255	0	0	699
<b>% Lights</b>	0.0%	0.0%	0.0%	0.0%	0.0%	0.0%	0.0%	96.4%	94.5%	0.0%	0.0%	95.0%	0.0%	0.0%	96.9%	94.2%	98.7%	0.0%	95.7%	0.0%	0.0%	0.0%	95.5%	98.2%	0.0%	96.6%	0.0%	0.0%	95.9%
<b>Trucks</b>	0	0	0	0	0	0	0	0	0	0	0	0	0	0	0	0	0	0	0	0	0	0	0	0	0	0	0	0	0
<b>% Trucks</b>	0.0%	0.0%	0.0%	0.0%	0.0%	0.0%	0.0%	0.0%	0.0%	0.0%	0.0%	0.0%	0.0%	0.0%	0.0%	0.0%	0.0%	0.0%	0.0%	0.0%	0.0%	0.0%	0.0%	0.0%	0.0%	0.0%	0.0%	0.0%	0.0%
<b>Buses</b>	0	0	0	0	0	0	0	1	5	0	0	6	0	0	2	11	1	0	14	0	0	0	6	2	0	8	0	0	28
<b>% Buses</b>	0.0%	0.0%	0.0%	0.0%	0.0%	0.0%	0.0%	3.6%	5.5%	0.0%	0.0%	0.0%	0.0%	0.0%	3.1%	5.3%	1.3%	0.0%	0.0%	0.0%	0.0%	3.9%	1.8%	0.0%	0.0%	0.0%	0.0%	3.8%	
<b>Pedestrians</b>	0	0	0	0	0	5	2	0	0	0	0	0	0	0	0	0	0	0	0	5	1	0	0	0	0	0	0	0	
<b>% Pedestrians</b>	0.0%	0.0%	0.0%	0.0%	0.0%	100.0%	100.0%	0.0%	0.0%	0.0%	0.0%	0.0%	0.0%	0.0%	0.0%	0.0%	0.0%	0.0%	0.0%	0.0%	100.0%	100.0%	0.0%	0.0%	0.0%	0.0%	0.0%	0.0%	0.0%
<b>Bicycles on Crosswalk</b>	0	0	0	0	0	0	0	0	0	0	0	0	0	0	0	0	0	0	0	0	0	0	0	0	0	0	0	0	0
<b>% Bicycles on Crosswalk</b>	0.0%	0.0%	0.0%	0.0%	0.0%	0.0%	0.0%	0.0%	0.0%	0.0%	0.0%	0.0%	0.0%	0.0%	0.0%	0.0%	0.0%	0.0%	0.0%	0.0%	0.0%	0.0%	0.0%	0.0%	0.0%	0.0%	0.0%	0.0%	0.0%

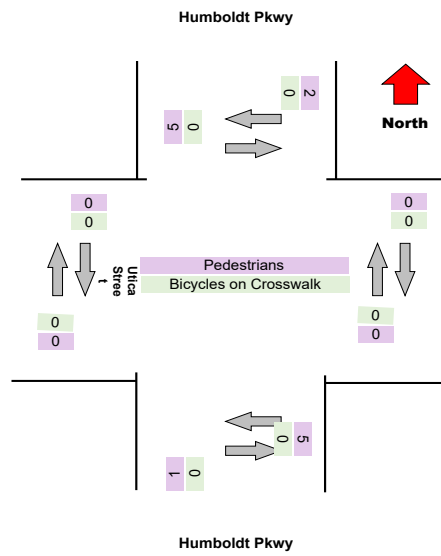
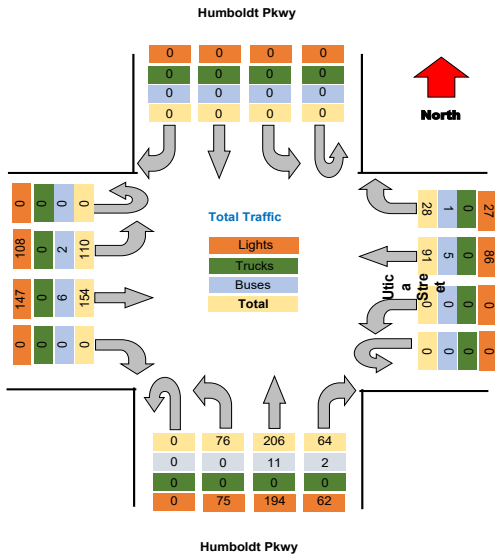



Project : VBH Malta NY  
 Site : Site 4  
 Location : 42.948550, -73.790036  
 Survey Date : 2021-04-28, Wednesday

### Turning Movement Data Plot

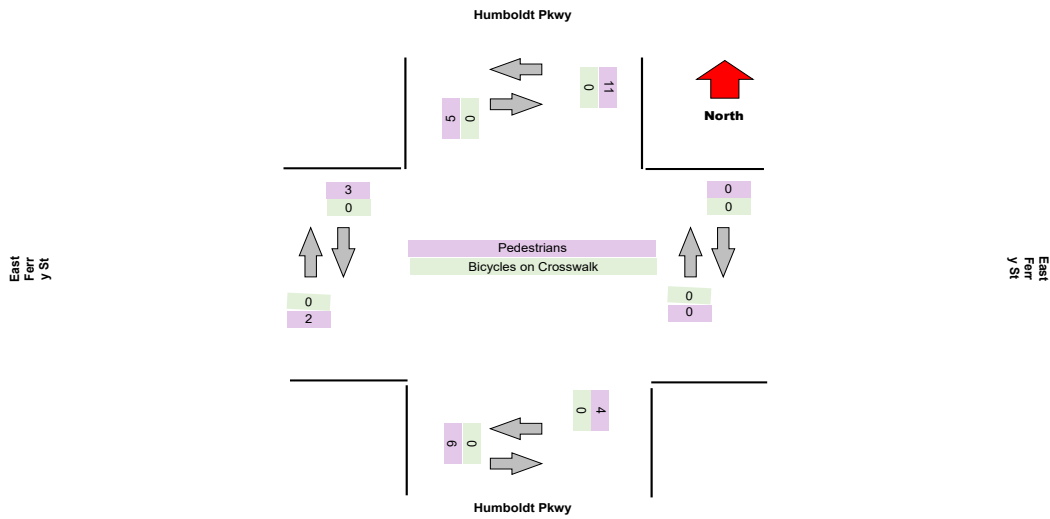
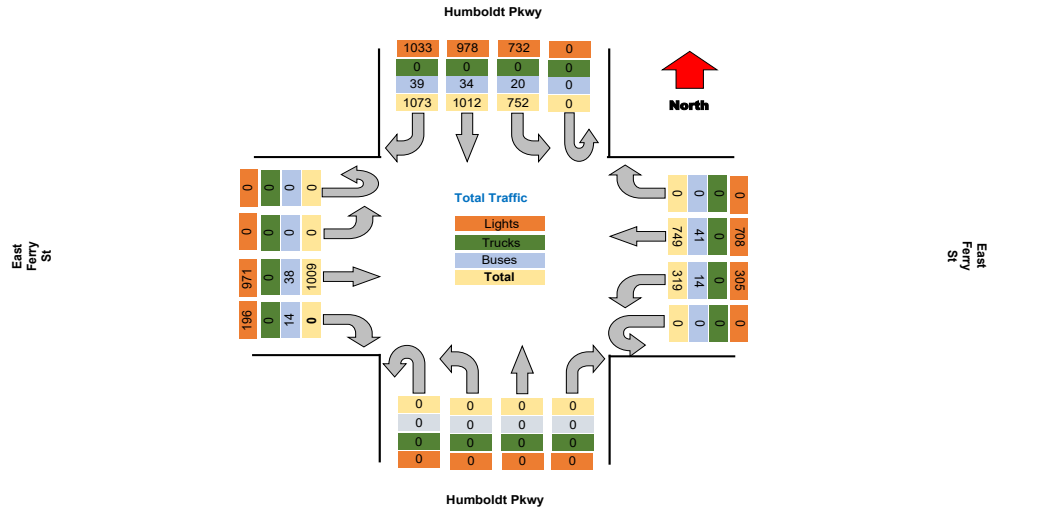

Project : VBH Malta NY  
Site : Site 4  
Location : 42.948550, -73.790036

TSTData.com

Survey Date : 2021-04-28, Wednesday

### Turning Movement Peak Hour Data (AM)

7:30:00 AM

Leg Direction	Humboldt Pkwy						East Ferry St						Humboldt Pkwy						East Ferry St						Total			
	Southbound			Northbound			Westbound			Eastbound			Northbound			Eastbound												
Start Time	Right	Thru	Left	U-Turn	App Total	Peds CW	Peds CCW	Right	Thru	Left	U-Turn	App Total	Peds CW	Peds CCW	Right	Thru	Left	U-Turn	App Total	Peds CW	Peds CCW	Right	Thru	Left	U-Turn	App Total	Peds CW	Peds CCW
7:30:00 AM	96	72	62	0	230	1	1	0	34	22	0	57	0	0	0	0	0	0	0	0	2	7	61	0	0	68	0	0
7:45:00 AM	108	60	55	0	223	1	1	0	31	19	0	51	0	0	0	0	0	0	1	1	11	61	0	0	72	0	0	
8:00:00 AM	83	52	35	0	170	1	1	0	49	15	0	65	0	0	0	0	0	0	1	1	10	68	0	0	78	0	0	
8:15:00 AM	68	68	45	0	181	1	1	0	48	31	0	79	0	0	0	0	0	0	1	1	14	43	0	0	57	0	0	
<b>Grand Total</b>	<b>355</b>	<b>252</b>	<b>197</b>	<b>0</b>	<b>804</b>	<b>3</b>	<b>3</b>	<b>0</b>	<b>152</b>	<b>87</b>	<b>0</b>	<b>239</b>	<b>0</b>	<b>0</b>	<b>0</b>	<b>0</b>	<b>0</b>	<b>2</b>	<b>2</b>	<b>42</b>	<b>233</b>	<b>0</b>	<b>0</b>	<b>275</b>	<b>3</b>	<b>3</b>		
<b>% Approach</b>	44.2%	31.3%	24.5%	0.0%	0.0%	0.0%	0.0%	14.2%	85.8%	0.0%	0.0%	0.0%	0.0%	0.0%	45.1%	41.7%	13.2%	0.0%	0.0%	0.0%	0.0%	0.0%	66.2%	33.8%	0.0%	0.0%	0.0%	0.0%
<b>% Total</b>	26.7%	18.9%	14.8%	0.0%	60.4%	0.0%	0.0%	0.0%	12.2%	6.5%	0.0%	19.0%	0.0%	0.0%	0.0%	0.0%	0.0%	0.0%	0.0%	0.0%	0.0%	3.2%	17.5%	0.0%	0.0%	20.6%	0.0%	0.0%
<b>PHF</b>	0.822	0.875	0.794	0.000	0.874	0.000	0.000	0.000	0.827	0.702	0.000	0.791	0.000	0.000	0.000	0.000	0.000	0.000	0.000	0.000	0.000	0.750	0.857	0.000	0.000	0.881	0.000	0.000
<b>Lights</b>	341	241	193	0	775	0	0	0	153	83	0	236	0	0	0	0	0	0	0	0	38	219	0	0	257	0	0	
<b>% Trucks</b>	0.0%	0.0%	0.0%	0.0%	0.0%	0.0%	0.0%	0.0%	0.0%	0.0%	0.0%	0.0%	0.0%	0.0%	0.0%	0.0%	0.0%	0.0%	0.0%	0.0%	0.0%	0.0%	0.0%	0.0%	0.0%	0.0%	0.0%	
<b>Buses</b>	13	11	4	0	28	0	0	0	9	4	0	13	0	0	0	0	0	0	0	0	4	14	0	0	18	0	0	
<b>% Buses</b>	3.7%	4.4%	2.0%	0.0%	0.0%	0.0%	0.0%	0.0%	5.6%	4.6%	0.0%	0.0%	0.0%	0.0%	0.0%	0.0%	0.0%	0.0%	0.0%	0.0%	9.5%	6.0%	0.0%	0.0%	0.0%	0.0%		
<b>Pedestrians</b>	0	0	0	0	0	3	4	0	0	0	0	0	0	0	0	0	0	0	2	4	0	0	0	0	0	0		
<b>% Pedestrians</b>	0.0%	0.0%	0.0%	0.0%	0.0%	100.0%	100.0%	0.0%	0.0%	0.0%	0.0%	0.0%	0.0%	0.0%	0.0%	0.0%	0.0%	0.0%	0.0%	0.0%	100.0%	100.0%	0.0%	0.0%	0.0%	0.0%		
<b>Bicycles on Crosswalk</b>	0	0	0	0	0	0	0	0	0	0	0	0	0	0	0	0	0	0	0	0	0	0	0	0	0	0		
<b>% Bicycles on Crosswalk</b>	0.0%	0.0%	0.0%	0.0%	0.0%	0.0%	0.0%	0.0%	0.0%	0.0%	0.0%	0.0%	0.0%	0.0%	0.0%	0.0%	0.0%	0.0%	0.0%	0.0%	0.0%	0.0%	0.0%	0.0%	0.0%	0.0%		

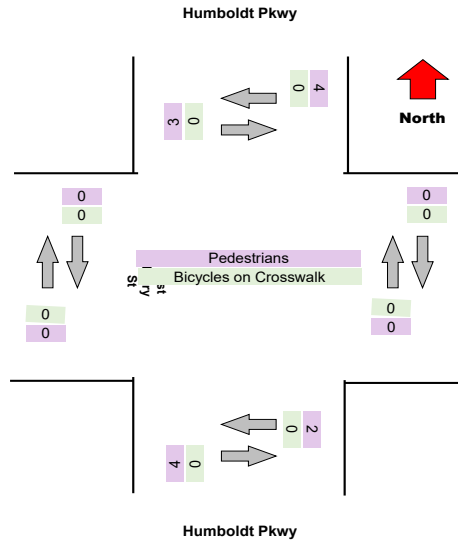
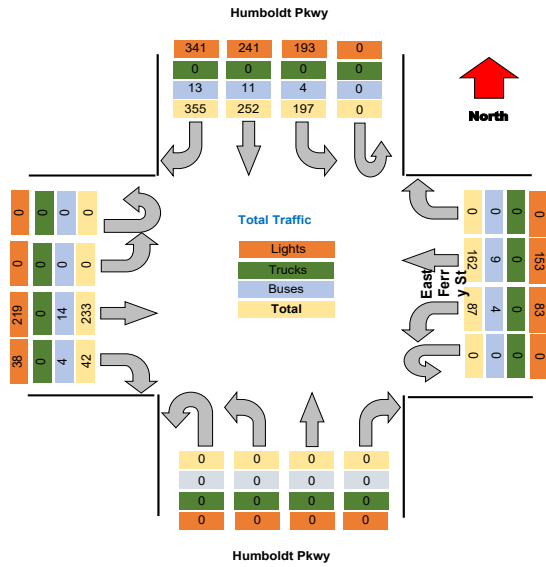



**Turning Movement Peak Hour Data (PM)**

4:15:00 PM

Leg Direction	Humboldt Pkwy										East Ferry St										Humboldt Pkwy										East Ferry St										Total
	Southbound					Westbound					Northbound					Eastbound																									
	Right	Thru	Left	U-Turn	App Total	Right	Thru	Left	U-Turn	App Total	Right	Thru	Left	U-Turn	App Total	Right	Thru	Left	U-Turn	App Total																					
4:15:00 PM	57	81	53	0	191	1	1	0	73	27	0	100	0	0	0	0	0	13	98	0	0	111	0	0	0	0	0	402													
4:30:00 PM	56	79	68	0	203	0	1	0	56	28	0	84	0	0	0	0	0	23	84	0	0	107	0	0	0	0	0	394													
4:45:00 PM	68	71	49	0	188	0	0	0	62	35	0	97	0	0	0	0	0	22	73	0	0	95	0	0	0	0	0	380													
5:00:00 PM	71	72	36	0	179	0	1	0	64	25	0	89	0	0	0	0	0	21	62	0	0	113	0	0	0	0	0	351													
<b>Grand Total</b>	<b>252</b>	<b>303</b>	<b>206</b>	<b>0</b>	<b>761</b>	<b>1</b>	<b>1</b>	<b>0</b>	<b>255</b>	<b>115</b>	<b>0</b>	<b>370</b>	<b>0</b>	<b>0</b>	<b>0</b>	<b>0</b>	<b>0</b>	<b>79</b>	<b>347</b>	<b>0</b>	<b>0</b>	<b>426</b>	<b>0</b>	<b>0</b>	<b>0</b>	<b>0</b>	<b>0</b>	<b>1557</b>													
% Approach	33.1%	39.6%	27.1%	0.0%	0.0%	0.0%	0.0%	0.0%	14.2%	85.8%	0.0%	0.0%	0.0%	0.0%	0.0%	0.0%	0.0%	45.1%	41.7%	13.2%	0.0%	0.0%	0.0%	66.2%	33.8%	0.0%	0.0%	0.0%													
% Total	16.2%	19.5%	13.2%	0.0%	48.8%	0.0%	0.0%	0.0%	0.0%	16.4%	7.4%	0.0%	23.8%	0.0%	0.0%	0.0%	0.0%	0.0%	0.0%	0.0%	0.0%	0.0%	0.0%	5.1%	22.3%	0.0%	0.0%	27.4%	0.0%												
PHF	0.887	0.935	0.757	0.000	0.937	0.000	0.000	0.000	0.000	0.873	0.821	0.000	0.925	0.000	0.000	0.000	0.000	0.000	0.000	0.859	0.885	0.000	0.000	0.942	0.000	0.000	0.000	0.000	0.968												
Lights	246	292	202	0	740	0	0	0	243	110	0	353	0	0	0	0	0	72	337	0	0	409	0	0	0	0	0	1502													
% Lights	97.6%	96.4%	98.1%	0.0%	97.2%	0.0%	0.0%	0.0%	95.3%	95.7%	0.0%	95.4%	0.0%	0.0%	0.0%	0.0%	0.0%	91.1%	97.1%	0.0%	0.0%	96.0%	0.0%	0.0%	0.0%	0.0%	0.0%	96.5%													
Trucks	0	0	0	0	0	0	0	0	0	0	0	0	0	0	0	0	0	0	0	0	0	0	0	0	0	0	0	0													
% Trucks	0.0%	0.0%	0.0%	0.0%	0.0%	0.0%	0.0%	0.0%	0.0%	0.0%	0.0%	0.0%	0.0%	0.0%	0.0%	0.0%	0.0%	0.0%	0.0%	0.0%	0.0%	0.0%	0.0%	0.0%	0.0%	0.0%	0.0%	0.0%													
Buses	6	11	4	0	21	0	0	0	12	5	0	17	0	0	0	0	0	7	10	0	0	17	0	0	0	0	0	55													
% Buses	2.4%	3.6%	1.9%	0.0%	0.0%	0.0%	0.0%	0.0%	4.7%	4.3%	0.0%	0.0%	0.0%	0.0%	0.0%	0.0%	0.0%	8.9%	2.9%	0.0%	0.0%	0.0%	0.0%	0.0%	0.0%	0.0%	0.0%	3.5%													
Pedestrians	0	0	0	0	0	1	3	0	0	0	0	0	0	0	0	0	0	3	0	0	0	0	0	0	0	0	0	0													
% Pedestrians	0.0%	0.0%	0.0%	0.0%	0.0%	100.0%	100.0%	0.0%	0.0%	0.0%	0.0%	0.0%	0.0%	0.0%	0.0%	0.0%	0.0%	100.0%	0.0%	0.0%	0.0%	0.0%	0.0%	0.0%	0.0%	0.0%	0.0%	0.0%													
Bicycles on Crosswalk	0	0	0	0	0	0	0	0	0	0	0	0	0	0	0	0	0	0	0	0	0	0	0	0	0	0	0	0													
% Bicycles on Crosswalk	0.0%	0.0%	0.0%	0.0%	0.0%	0.0%	0.0%	0.0%	0.0%	0.0%	0.0%	0.0%	0.0%	0.0%	0.0%	0.0%	0.0%	0.0%	0.0%	0.0%	0.0%	0.0%	0.0%	0.0%	0.0%	0.0%	0.0%	0.0%													

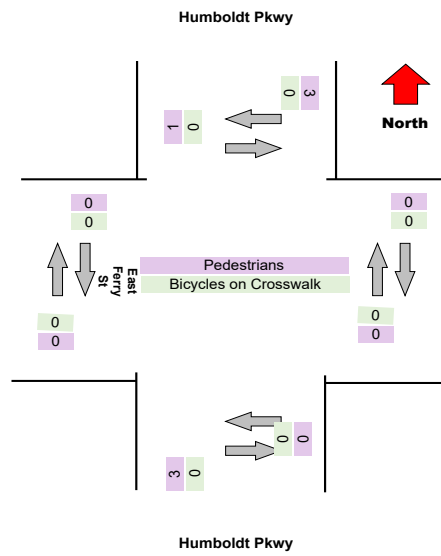
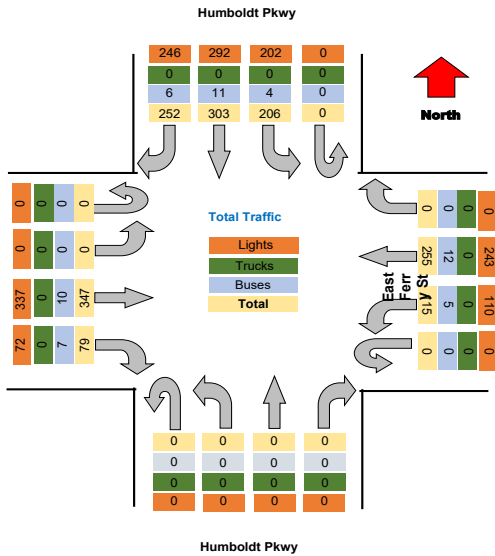

Project : VBH Malta NY  
 Site : Site 4  
 Location : 42.948550, -73.790036

TSTData.com

Survey Date : 2021-04-28, Wednesday

Project	Labella
Project Code	Labella
Site Name	8
Legs and Movements	All Processed Legs & Move
Bin Size	15 minutes
Survey Date	2021-10-27, Wednesday
Location	8
Latitude and Longitude	42.914700, -78.843693

	Start	End	PHF
Forced Peak AM	2021/10/27 07:30:00	2021/10/27 08:30:00	0.89
Forced Peak PM	2021/10/27 16:30:00	2021/10/27 17:30:00	0.85
AM Peak	2021/10/27 07:30:00	2021/10/27 08:30:00	0.89
PM Peak	2021/10/27 16:15:00	2021/10/27 17:15:00	0.89

### Turning Movement Data

Leg Direction	Humboldt Pkwy								East Ferry St								Humboldt Pkwy								East Ferry St								Total	
	Southbound				Westbound				Northbound				Eastbound				Westbound				Eastbound													
	Right	Thru	Left	U-Turn	App Total	Peds CV	Peds CCV		Right	Thru	Left	U-Turn	App Total	Peds CV	Peds CCV		Right	Thru	Left	U-Turn	App Total	Peds CV	Peds CCV		Right	Thru	Left	U-Turn	App Total	Peds CV	Peds CCV			
Start Time	48	31	22	0	101	0	0	0	18	6	0	24	0	0	0	0	0	0	0	0	0	0	0	0	0	0	6	23	0	0	29	0	0	154
6:30:00 AM	37	42	29	0	108	0	0	0	24	6	0	30	0	0	0	0	0	0	0	0	0	0	0	0	0	0	3	25	0	0	28	0	0	166
6:45:00 AM	85	73	51	0	209	0	0	0	42	12	0	54	0	0	0	0	0	0	0	0	0	0	0	0	0	0	9	48	0	0	57	0	0	320
Hourly Total	31	22	29	0	82	1	0	0	28	11	0	39	0	0	0	0	0	0	0	0	0	0	0	0	0	0	8	34	0	0	42	0	0	163
7:00:00 AM	95	49	53	0	197	1	0	0	37	13	0	50	0	0	0	0	0	0	0	0	0	0	0	0	0	0	8	41	0	0	49	1	1	296
7:15:00 AM	83	71	49	0	203	0	0	0	38	11	0	49	0	0	0	0	0	0	0	0	0	0	0	0	0	0	11	66	0	0	77	0	0	329
7:30:00 AM	126	75	53	0	254	1	0	0	47	22	0	69	0	0	0	0	0	0	0	0	0	0	0	0	0	0	9	67	0	0	76	0	0	399
7:45:00 AM	335	217	184	0	736	3	0	0	150	57	0	207	0	0	0	0	0	0	0	0	0	0	0	0	0	0	36	208	0	0	244	1	1	1187
Hourly Total	107	69	38	0	214	0	0	0	49	23	0	72	0	0	0	0	0	0	0	0	0	0	0	0	0	0	10	70	0	0	80	0	0	366
8:00:00 AM	74	67	38	0	179	0	0	0	50	25	0	75	0	0	0	0	0	0	0	0	0	0	0	0	0	0	13	58	0	0	71	0	0	325
8:15:00 AM	181	136	76	0	393	0	0	0	99	48	0	147	0	0	0	0	0	0	0	0	0	0	0	0	0	0	23	128	0	0	151	0	0	691
Hourly Total	62	83	67	0	212	1	0	0	53	21	0	74	0	0	0	0	0	0	0	0	0	0	0	0	0	0	22	107	0	0	129	1	1	415
4:00:00 PM	82	84	83	0	249	0	0	0	79	20	0	99	0	0	0	0	0	0	0	0	0	0	0	3	4	0	16	109	0	0	125	0	4	473
4:15:00 PM	69	77	59	0	205	1	0	0	66	33	0	99	0	0	0	0	0	0	0	0	0	0	0	0	0	0	18	96	0	0	116	1	0	420
4:30:00 PM	92	73	63	0	228	0	0	0	68	18	0	86	0	0	0	0	0	0	0	0	0	0	0	0	0	0	13	77	0	0	90	0	1	404
4:45:00 PM	305	317	272	0	894	2	2	0	268	92	0	358	0	0	0	0	0	0	0	0	0	0	0	3	5	0	69	391	0	0	460	2	6	1712
Hourly Total	71	72	44	0	187	0	0	0	68	28	0	94	0	0	0	0	0	0	0	0	0	0	0	3	0	0	12	87	0	0	99	0	0	380
5:00:00 PM	71	85	47	0	203	2	3	0	57	22	0	79	0	0	0	0	0	0	0	0	0	0	0	2	0	0	11	92	0	0	103	2	1	385
5:15:00 PM	74	75	53	0	202	3	2	0	52	18	0	70	0	0	0	0	0	0	0	0	0	0	0	1	0	0	10	61	0	0	71	0	0	343
5:30:00 PM	78	64	62	0	204	0	0	0	58	23	0	81	0	0	0	0	0	0	0	0	0	0	0	0	0	0	13	76	0	0	89	0	0	374
5:45:00 PM	294	296	206	0	796	5	5	0	233	91	0	324	0	0	0	0	0	0	0	0	0	0	0	6	0	0	46	316	0	0	362	2	1	1482
Hourly Total	1200	1039	789	0	3028	10	7	0	790	300	0	1090	0	0	0	0	0	0	0	0	0	0	0	9	8	0	183	1091	0	0	1274	5	10	5392
Grand Total	39.6%	34.3%	26.1%	0.0%	0.0%	0.0%	0.0%	0.0%	72.5%	27.5%	0.0%	0.0%	0.0%	0.0%	0.0%	0.0%	0.0%	0.0%	0.0%	0.0%	0.0%	0.0%	0.0%	0.0%	0.0%	0.0%	14.4%	85.6%	0.0%	0.0%	0.0%	0.0%	0.0%	0.0%
% Approach	22.3%	19.3%	14.6%	0.0%	56.2%	0.0%	0.0%	0.0%	14.7%	5.6%	0.0%	20.2%	0.0%	0.0%	0.0%	0.0%	0.0%	0.0%	0.0%	0.0%	0.0%	0.0%	0.0%	0.0%	0.0%	0.0%	3.4%	20.2%	0.0%	0.0%	23.8%	0.0%	0.0%	0.0%
% Total	1175	998	763	0	2936	0	0	0	744	286	0	1030	0	0	0	0	0	0	0	0	0	0	0	0	0	0	171	1045	0	0	1216	0	0	5182
Lights	97.9%	96.1%	95.7%	0.0%	97.0%	0.0%	0.0%	0.0%	94.2%	95.3%	0.0%	94.5%	0.0%	0.0%	0.0%	0.0%	0.0%	0.0%	0.0%	0.0%	0.0%	0.0%	0.0%	0.0%	0.0%	0.0%	93.4%	95.8%	0.0%	0.0%	95.4%	0.0%	0.0%	96.1%
% Lights	0	0	1	0	1	0	0	0	1	0	0	1	0	0	0	0	0	0	0	0	0	0	0	0	0	0	0	1	0	0	1	0	0	3
Trucks	0.0%	0.0%	0.1%	0.0%	0.0%	0.0%	0.0%	0.0%	0.1%	0.0%	0.0%	0.1%	0.0%	0.0%	0.0%	0.0%	0.0%	0.0%	0.0%	0.0%	0.0%	0.0%	0.0%	0.0%	0.0%	0.0%	0.0%	0.1%	0.0%	0.0%	0.1%	0.0%	0.0%	0.1%
% Trucks	25	40	25	0	90	0	0	0	43	13	0	56	0	0	0	0	0	0	0	0	0	0	0	0	0	0	12	45	0	0	57	0	0	203
Buses	2.1%	3.8%	3.2%	0.0%	0.0%	0.0%	0.0%	0.0%	5.4%	4.3%	0.0%	0.0%	0.0%	0.0%	0.0%	0.0%	0.0%	0.0%	0.0%	0.0%	0.0%	0.0%	0.0%	0.0%	0.0%	6.6%	4.1%	0.0%	0.0%	0.0%	0.0%	0.0%	3.8%	
% Buses	0	0	0	0	0	0	0	0	0	0	0	0	0	0	0	0	0	0	0	0	0	0	0	0	0	0	0	0	0	0	0	4	0	0
Pedestrians	0.0%	0.0%	0.0%	0.0%	0.0%	80.0%	85.7%	0.0%	0.0%	0.0%	0.0%	0.0%	0.0%	0.0%	0.0%	0.0%	0.0%	0.0%	0.0%	0.0%	0.0%	0.0%	100.0%	83.3%	0.0%	0.0%	0.0%	0.0%	0.0%	0.0%	80.0%	80.0%	0.0%	
% Pedestrians	0	0	0	0	0	1	1	0	0	0	0	0	0	0	0	0	0	0	0	0	0	0	0	0	0	0	0	0	0	0	1	1	0	
Bicycles on Crosswalk	0.0%	0.0%	0.0%	0.0%	0.0%	10.0%	14.3%	0.0%	0.0%	0.0%	0.0%	0.0%	0.0%	0.0%	0.0%	0.0%	0.0%	0.0%	0.0%	0.0%	0.0%	0.0%	0.0%	16.7%	0.0%	0.0%	0.0%	0.0%	0.0%	20.0%	10.0%	0.0%		
% Bicycles on Crosswalk																																		

Project : VBH Malta NY  
 Site : Site 4  
 Location : 42.948550, -73.790036  
 Survey Date : 2021-04-28, Wednesday

### Turning Movement Data Plot

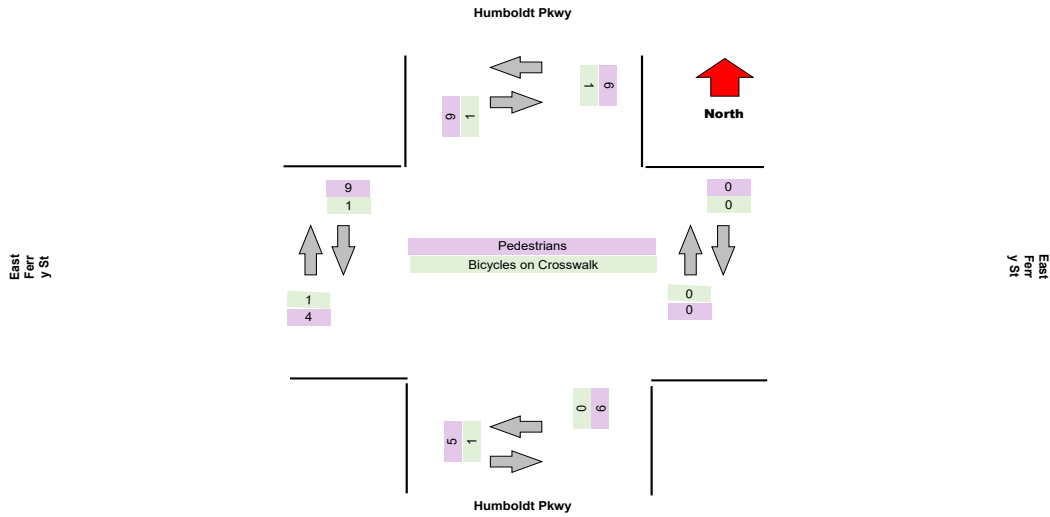
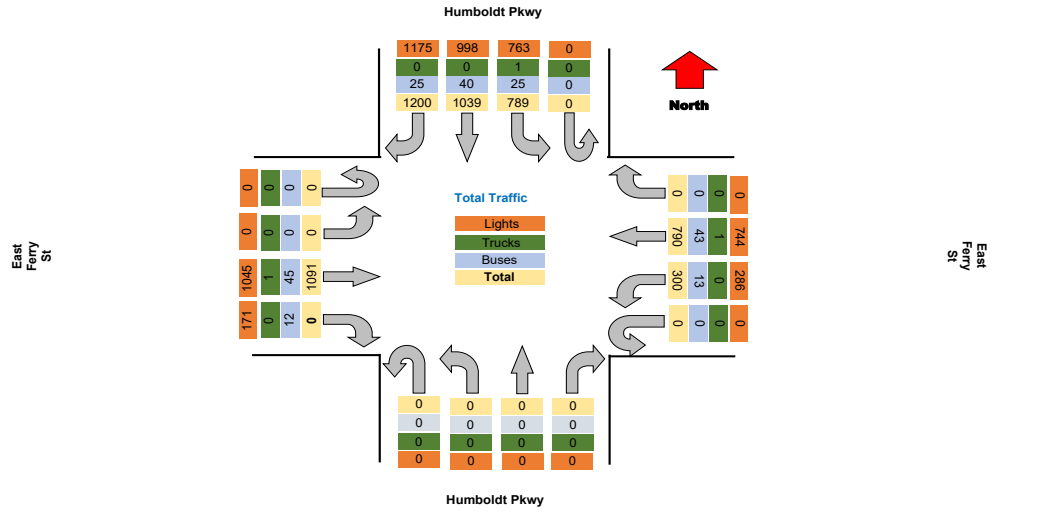

**Turning Movement Peak Hour Data (AM)**

7:30:00 AM

Leg Direction	Humboldt Pkwy								East Ferry St								Humboldt Pkwy								East Ferry St								Total
	Southbound				Northbound				Westbound				Eastbound				Northbound				Eastbound												
Start Time	Right	Thru	Left	U-Turn	App Total	Peds CW	Peds CCW	Right	Thru	Left	U-Turn	App Total	Peds CW	Peds CCW	Right	Thru	Left	U-Turn	App Total	Peds CW	Peds CCW	Right	Thru	Left	U-Turn	App Total	Peds CW	Peds CCW					
7:30:00 AM	83	71	49	0	203	0	0	0	38	11	0	49	0	0	0	0	0	0	0	0	0	0	11	66	0	0	77	0	0	329			
7:45:00 AM	126	75	53	0	254	1	0	0	47	22	0	69	0	0	0	0	0	0	0	0	0	9	67	0	0	76	0	0	399				
8:00:00 AM	107	69	38	0	214	0	0	0	49	23	0	72	0	0	0	0	0	0	0	0	0	10	70	0	0	80	0	0	366				
8:15:00 AM	74	67	36	0	177	0	0	0	50	25	0	75	0	0	0	0	0	0	0	0	0	13	58	0	0	71	0	0	325				
<b>Grand Total</b>	<b>390</b>	<b>282</b>	<b>178</b>	<b>0</b>	<b>850</b>	<b>1</b>	<b>0</b>	<b>0</b>	<b>184</b>	<b>81</b>	<b>0</b>	<b>265</b>	<b>0</b>	<b>0</b>	<b>0</b>	<b>0</b>	<b>0</b>	<b>0</b>	<b>0</b>	<b>0</b>	<b>0</b>	<b>43</b>	<b>261</b>	<b>0</b>	<b>0</b>	<b>304</b>	<b>0</b>	<b>0</b>	<b>1419</b>				
% Approach	45.9%	33.2%	20.9%	0.0%	0.0%	0.0%	0.0%	14.2%	85.8%	0.0%	0.0%	0.0%	0.0%	0.0%	45.1%	41.7%	13.2%	0.0%	0.0%	0.0%	0.0%	0.0%	66.2%	33.8%	0.0%	0.0%	0.0%	0.0%	0.0%				
% Total	27.5%	19.9%	12.5%	0.0%	59.9%	0.0%	0.0%	0.0%	13.0%	5.7%	0.0%	18.7%	0.0%	0.0%	0.0%	0.0%	0.0%	0.0%	0.0%	0.0%	0.0%	3.0%	18.4%	0.0%	0.0%	21.4%	0.0%	0.0%	0.0%				
PHF	0.774	0.940	0.840	0.000	0.837	0.000	0.000	0.000	0.920	0.810	0.000	0.883	0.000	0.000	0.000	0.000	0.000	0.000	0.000	0.000	0.000	0.827	0.932	0.000	0.000	0.950	0.000	0.000	0.889				
Lights	385	266	175	0	826	0	0	0	172	76	0	248	0	0	0	0	0	0	0	0	0	40	245	0	0	285	0	0	1369				
% Lights	88.7%	84.3%	88.3%	0.0%	97.2%	0.0%	0.0%	0.0%	93.5%	93.8%	0.0%	93.6%	0.0%	0.0%	0.0%	0.0%	0.0%	0.0%	0.0%	0.0%	0.0%	93.0%	93.9%	0.0%	0.0%	93.8%	0.0%	0.0%	95.8%				
Trucks	0	0	0	0	0	0	0	0	1	0	0	1	0	0	0	0	0	0	0	0	0	0	0	0	0	0	0	0	1				
% Trucks	0.0%	0.0%	0.0%	0.0%	0.0%	0.0%	0.0%	0.0%	0.5%	0.0%	0.0%	0.4%	0.0%	0.0%	0.0%	0.0%	0.0%	0.0%	0.0%	0.0%	0.0%	0.0%	0.0%	0.0%	0.0%	0.0%	0.0%	0.0%	0.1%				
Buses	5	16	3	0	24	0	0	0	11	5	0	16	0	0	0	0	0	0	0	0	0	3	16	0	0	19	0	0	59				
% Buses	1.3%	5.7%	1.7%	0.0%	0.0%	0.0%	0.0%	0.0%	6.0%	6.2%	0.0%	0.0%	0.0%	0.0%	0.0%	0.0%	0.0%	0.0%	0.0%	0.0%	0.0%	7.0%	6.1%	0.0%	0.0%	0.0%	0.0%	0.0%	4.2%				
Pedestrians	0	0	0	0	0	1	0	0	0	0	0	0	0	0	0	0	0	0	0	0	1	0	0	0	0	0	0	0	0				
% Pedestrians	0.0%	0.0%	0.0%	0.0%	0.0%	100.0%	0.0%	0.0%	0.0%	0.0%	0.0%	0.0%	0.0%	0.0%	0.0%	0.0%	0.0%	0.0%	0.0%	0.0%	0.0%	100.0%	0.0%	0.0%	0.0%	0.0%	0.0%	0.0%	0.0%				
Bicycles on Crosswalk	0	0	0	0	0	0	0	0	0	0	0	0	0	0	0	0	0	0	0	0	0	0	0	0	0	0	0	0	0				
% Bicycles on Crosswalk	0.0%	0.0%	0.0%	0.0%	0.0%	0.0%	0.0%	0.0%	0.0%	0.0%	0.0%	0.0%	0.0%	0.0%	0.0%	0.0%	0.0%	0.0%	0.0%	0.0%	0.0%	0.0%	0.0%	0.0%	0.0%	0.0%	0.0%	0.0%	0.0%				

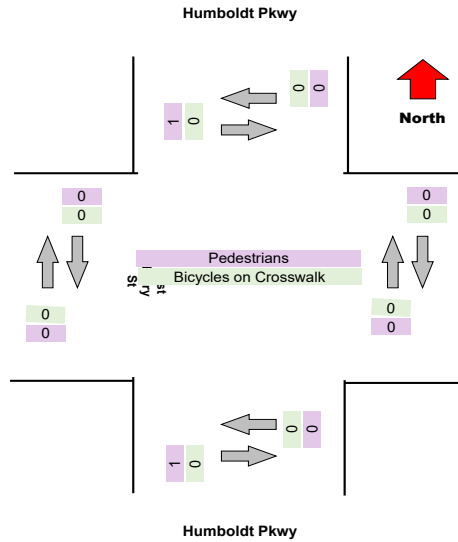
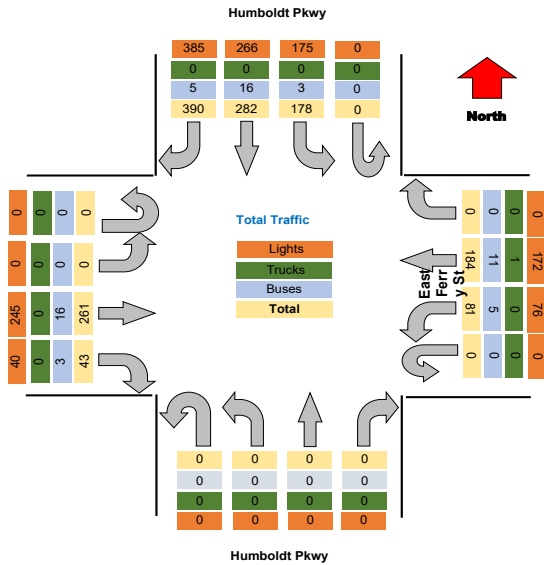

Project : VBH Malta NY  
Site : Site 4  
Location : 42.948550, -73.790036

TSTData.com

Survey Date : 2021-04-28, Wednesday

### Turning Movement Peak Hour Data (PM)

4:15:00 PM

Leg Direction	Humboldt Pkwy					East Ferry St					Humboldt Pkwy					East Ferry St					Total								
	Southbound					Westbound					Northbound					Eastbound													
Start Time	Right	Thru	Left	U-Turn	App Total	Peds CW	Peds CCW	Right	Thru	Left	U-Turn	App Total	Peds CW	Peds CCW	Right	Thru	Left	U-Turn	App Total	Peds CW	Peds CCW	Right	Thru	Left	U-Turn	App Total	Peds CW	Peds CCW	
4:15:00 PM	82	84	83	0	249	0	0	0	79	20	0	99	0	0	0	0	0	0	0	3	4	16	109	0	0	125	0	4	473
4:30:00 PM	69	77	59	0	205	1	0	0	66	33	0	99	0	0	0	0	0	0	0	0	0	18	98	0	0	116	1	0	420
4:45:00 PM	92	73	63	0	228	0	2	0	68	18	0	86	0	0	0	0	0	0	0	0	1	13	77	0	0	90	0	1	404
5:00:00 PM	71	72	44	0	187	0	0	0	65	28	0	94	0	0	0	0	0	0	0	0	0	12	67	0	0	99	0	0	380
<b>Grand Total</b>	<b>314</b>	<b>306</b>	<b>249</b>	<b>0</b>	<b>869</b>	<b>1</b>	<b>2</b>	<b>0</b>	<b>279</b>	<b>99</b>	<b>0</b>	<b>378</b>	<b>0</b>	<b>0</b>	<b>0</b>	<b>0</b>	<b>0</b>	<b>0</b>	<b>0</b>	<b>3</b>	<b>5</b>	<b>59</b>	<b>371</b>	<b>0</b>	<b>0</b>	<b>430</b>	<b>1</b>	<b>5</b>	<b>1677</b>
% Approach	36.1%	35.2%	28.7%	0.0%	0.0%	0.0%	0.0%	14.2%	85.6%	0.0%	0.0%	0.0%	0.0%	0.0%	45.1%	41.7%	13.2%	0.0%	0.0%	0.0%	0.0%	0.0%	66.2%	33.8%	0.0%	0.0%	0.0%	0.0%	0.0%
% Total	18.7%	18.2%	14.8%	0.0%	51.8%	0.0%	0.0%	0.0%	16.6%	5.9%	0.0%	22.5%	0.0%	0.0%	0.0%	0.0%	0.0%	0.0%	0.0%	0.0%	0.0%	3.5%	22.1%	0.0%	0.0%	25.6%	0.0%	0.0%	
PHF	0.853	0.911	0.750	0.000	0.872	0.000	0.000	0.000	0.883	0.750	0.000	0.955	0.000	0.000	0.000	0.000	0.000	0.000	0.000	0.000	0.000	0.819	0.851	0.000	0.000	0.860	0.000	0.000	0.886
Lights	310	296	239	0	845	0	0	0	264	96	0	360	0	0	0	0	0	0	0	0	0	54	363	0	0	417	0	0	1622
% Lights	88.7%	86.7%	96.0%	0.0%	97.2%	0.0%	0.0%	0.0%	94.6%	97.0%	0.0%	95.2%	0.0%	0.0%	0.0%	0.0%	0.0%	0.0%	0.0%	0.0%	0.0%	91.5%	97.8%	0.0%	0.0%	97.0%	0.0%	0.0%	96.7%
Trucks	0	0	0	0	0	0	0	0	0	0	0	0	0	0	0	0	0	0	0	0	0	0	0	0	0	0	0	0	0
% Trucks	0.0%	0.0%	0.0%	0.0%	0.0%	0.0%	0.0%	0.0%	0.0%	0.0%	0.0%	0.0%	0.0%	0.0%	0.0%	0.0%	0.0%	0.0%	0.0%	0.0%	0.0%	0.0%	0.0%	0.0%	0.0%	0.0%	0.0%	0.0%	0.0%
Buses	4	9	10	0	23	0	0	0	13	3	0	16	0	0	0	0	0	0	0	0	0	5	8	0	0	13	0	0	52
% Buses	1.3%	2.9%	4.0%	0.0%	0.0%	0.0%	0.0%	0.0%	4.7%	3.0%	0.0%	0.0%	0.0%	0.0%	0.0%	0.0%	0.0%	0.0%	0.0%	0.0%	0.0%	8.5%	2.2%	0.0%	0.0%	0.0%	0.0%	0.0%	3.1%
Pedestrians	0	0	0	0	0	1	0	0	0	0	0	0	0	0	6	4	0	0	0	0	0	0	0	0	0	0	1	4	0
% Pedestrians	0.0%	0.0%	0.0%	0.0%	0.0%	50.0%	0.0%	0.0%	0.0%	0.0%	0.0%	0.0%	0.0%	0.0%	100.0%	80.0%	0.0%	0.0%	0.0%	0.0%	0.0%	0.0%	0.0%	0.0%	0.0%	0.0%	100.0%	80.0%	0.0%
Bicycles on Crosswalk	0	0	0	0	1	1	0	0	0	0	0	0	0	0	0	0	0	0	0	0	0	1	0	0	0	0	1	0	0
% Bicycles on Crosswalk	0.0%	0.0%	0.0%	0.0%	0.0%	100.0%	50.0%	0.0%	0.0%	0.0%	0.0%	0.0%	0.0%	0.0%	0.0%	0.0%	0.0%	0.0%	0.0%	0.0%	0.0%	0.0%	0.0%	0.0%	0.0%	0.0%	0.0%	20.0%	0.0%

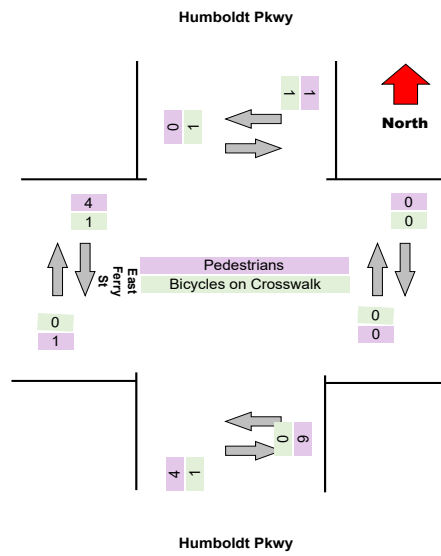
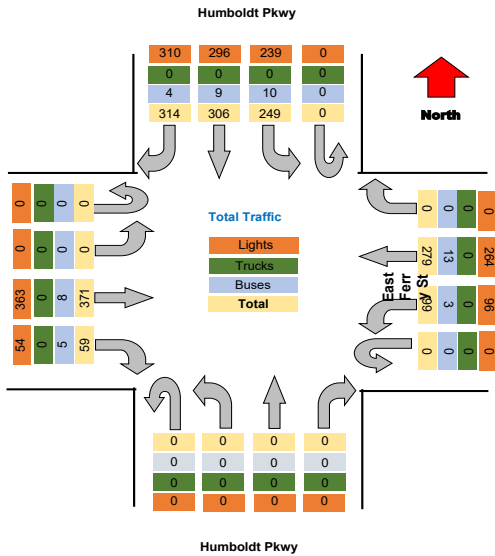

Project : VBH Malta NY  
 Site : Site 4  
 Location : 42.948550, -73.790036

TSTData.com

Survey Date : 2021-04-28, Wednesday

Project	Labella
Project Code	Labella
Site Name	8
Legs and Movements	All Processed Legs & Move
Bin Size	15 minutes
Survey Date	2021-10-28, Thursday
Location	8
Latitude and Longitude	42.914700, -78.843693

	Start	End	PHF
Forced Peak AM	2021/10/28 07:30:00	2021/10/28 08:30:00	0.89
Forced Peak PM	2021/10/28 16:30:00	2021/10/28 17:30:00	0.98
AM Peak	2021/10/28 07:30:00	2021/10/28 08:30:00	0.89
PM Peak	2021/10/28 16:15:00	2021/10/28 17:15:00	0.92

### Turning Movement Data

Leg Direction	Humboldt Pkwy					East Ferry St					Humboldt Pkwy					East Ferry St					Total									
	Southbound					Westbound					Northbound					Eastbound														
Start Time	Right	Thru	Left	U-Turn	App Total	Peds CV	Peds CCV	Right	Thru	Left	U-Turn	App Total	Peds CV	Peds CCV	Right	Thru	Left	U-Turn	App Total	Peds CV	Peds CCV	Right	Thru	Left	U-Turn	App Total	Peds CV	Peds CCV		
6:30:00 AM	31	27	23	0	81	0	0	0	15	6	0	21	0	0	0	0	0	0	0	0	0	0	6	34	0	0	40	0	0	
6:45:00 AM	48	28	33	0	119	0	0	0	25	13	0	38	0	0	0	0	0	0	0	0	0	0	7	18	0	0	25	0	0	
Hourly Total	79	55	56	0	209	0	0	0	40	19	0	59	0	0	0	0	0	0	0	0	0	0	13	52	0	0	65	0	1	
7:00:00 AM	36	24	32	0	92	0	0	0	23	12	0	35	0	0	0	0	0	0	0	0	0	0	3	32	0	0	35	0	0	
7:15:00 AM	58	48	34	0	140	1	0	0	25	11	0	36	0	0	0	0	0	0	0	0	0	0	6	32	0	0	38	1	1	
7:30:00 AM	93	69	57	0	219	0	0	0	35	15	0	50	0	0	0	0	0	0	0	0	1	2	14	57	0	0	71	2	0	
7:45:00 AM	102	94	53	0	249	0	1	0	41	27	0	69	0	0	0	0	0	0	0	0	0	0	11	73	0	0	84	0	0	
Hourly Total	289	235	178	0	709	1	1	0	124	65	0	190	0	0	0	0	0	0	0	0	1	2	34	194	0	0	228	3	1	
8:00:00 AM	100	75	49	0	224	0	0	0	37	20	0	57	0	0	0	0	0	0	0	0	0	0	10	73	0	0	83	0	0	
8:15:00 AM	79	71	50	0	200	1	0	0	46	25	0	71	0	0	0	0	0	0	0	0	0	0	11	43	0	0	54	0	0	
Hourly Total	179	146	99	0	424	1	0	0	83	45	0	128	0	0	0	0	0	0	0	0	0	0	21	116	0	0	137	0	0	
4:00:00 PM	68	85	56	0	209	2	0	0	88	34	0	122	0	0	0	0	0	0	0	0	2	0	19	115	0	0	134	0	0	
4:15:00 PM	86	95	73	0	254	0	0	0	69	36	0	105	0	0	0	0	0	0	0	0	0	0	18	92	0	0	110	0	1	
4:30:00 PM	86	85	61	0	232	0	1	0	50	35	0	85	0	0	0	0	0	0	0	0	1	0	17	82	0	0	99	0	0	
4:45:00 PM	77	79	61	0	217	0	1	0	75	23	0	98	0	0	0	0	0	0	0	0	1	0	17	89	0	0	106	0	0	
Hourly Total	317	344	251	0	912	2	2	0	282	128	0	410	0	0	0	0	0	0	0	2	3	0	71	378	0	0	449	0	1	
5:00:00 PM	79	92	58	0	229	0	0	0	56	20	0	76	0	0	0	0	0	0	0	1	0	0	12	105	0	0	117	0	1	
5:15:00 PM	73	79	57	0	209	0	0	0	56	18	0	74	0	0	0	0	0	0	0	2	0	0	11	94	0	0	105	0	0	
5:30:00 PM	81	85	65	0	231	0	1	0	58	23	0	81	0	0	0	0	0	0	0	0	1	0	12	92	0	0	104	1	1	
5:45:00 PM	86	82	49	0	217	0	1	0	64	26	0	90	0	0	0	0	0	0	0	0	2	0	16	86	0	0	82	1	1	
Hourly Total	319	338	229	0	886	0	2	0	234	87	0	321	0	0	0	0	0	0	0	3	3	0	51	357	0	0	408	2	3	
Grand Total	1183	1128	811	0	3122	4	6	0	763	344	0	1108	0	0	0	0	0	0	0	6	8	0	190	1097	0	0	1287	5	6	
% Approach	37.9%	36.1%	26.0%	0.0%	0.0%	0.0%	0.0%	0.0%	68.9%	31.0%	0.0%	0.0%	0.0%	0.0%	0.0%	0.0%	0.0%	0.0%	0.0%	0.0%	0.0%	0.0%	14.8%	85.2%	0.0%	0.0%	0.0%	0.0%	0.0%	
% Total	21.4%	20.4%	14.7%	0.0%	56.6%	0.0%	0.0%	0.0%	13.8%	6.2%	0.0%	20.1%	0.0%	0.0%	0.0%	0.0%	0.0%	0.0%	0.0%	0.0%	0.0%	0.0%	3.4%	19.8%	0.0%	0.0%	23.3%	0.0%	0.0%	
Lights	1151	1089	785	0	3025	0	0	0	723	334	0	1057	0	0	0	0	0	0	0	0	0	0	179	1059	0	0	1238	0	0	
% Lights	97.3%	96.5%	96.0%	0.0%	96.9%	0.0%	0.0%	0.0%	94.8%	97.1%	0.0%	95.4%	0.0%	0.0%	0.0%	0.0%	0.0%	0.0%	0.0%	0.0%	0.0%	0.0%	94.2%	96.5%	0.0%	0.0%	96.2%	0.0%	0.0%	
Trucks	0	1	1	0	2	0	0	0	2	0	0	2	0	0	0	0	0	0	0	0	0	0	0	0	0	0	0	0	0	
% Trucks	0.0%	0.1%	0.1%	0.0%	0.1%	0.0%	0.0%	0.0%	0.3%	0.0%	0.0%	0.2%	0.0%	0.0%	0.0%	0.0%	0.0%	0.0%	0.0%	0.0%	0.0%	0.0%	0.0%	0.0%	0.0%	0.0%	0.0%	0.0%	0.1%	
Buses	30	37	25	0	92	0	0	0	38	10	0	48	0	0	0	0	0	0	0	0	0	0	11	34	0	0	45	0	0	
% Buses	2.5%	3.3%	3.1%	0.0%	0.0%	0.0%	0.0%	0.0%	5.0%	2.9%	0.0%	0.0%	0.0%	0.0%	0.0%	0.0%	0.0%	0.0%	0.0%	0.0%	0.0%	0.0%	5.8%	3.1%	0.0%	0.0%	0.0%	0.0%	0.0%	
Pedestrians	0	0	0	0	0	4	4	0	0	0	0	0	0	0	0	0	0	0	0	0	0	6	7	0	0	0	4	4	0	
% Pedestrians	0.0%	0.0%	0.0%	0.0%	0.0%	100.0%	80.0%	0.0%	0.0%	0.0%	0.0%	0.0%	0.0%	0.0%	0.0%	0.0%	0.0%	0.0%	0.0%	0.0%	0.0%	100.0%	87.9%	0.0%	0.0%	0.0%	0.0%	80.0%	66.7%	0.0%
Bicycles on Crosswalk	0	0	0	0	0	0	1	0	0	0	0	0	0	0	0	0	0	0	0	0	0	0	0	0	0	0	1	2	0	
% Bicycles on Crosswalk	0.0%	0.0%	0.0%	0.0%	0.0%	0.0%	20.0%	0.0%	0.0%	0.0%	0.0%	0.0%	0.0%	0.0%	0.0%	0.0%	0.0%	0.0%	0.0%	0.0%	0.0%	0.0%	0.0%	0.0%	0.0%	0.0%	0.0%	20.0%	33.3%	

Project : VBH Malta NY  
 Site : Site 4  
 Location : 42.948550, -73.790036  
 Survey Date : 2021-04-28, Wednesday

### Turning Movement Data Plot

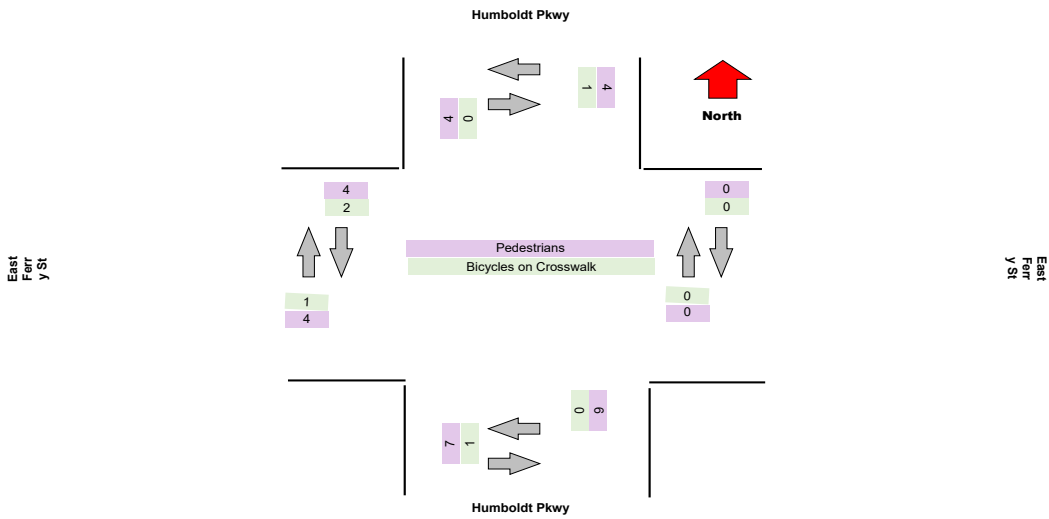
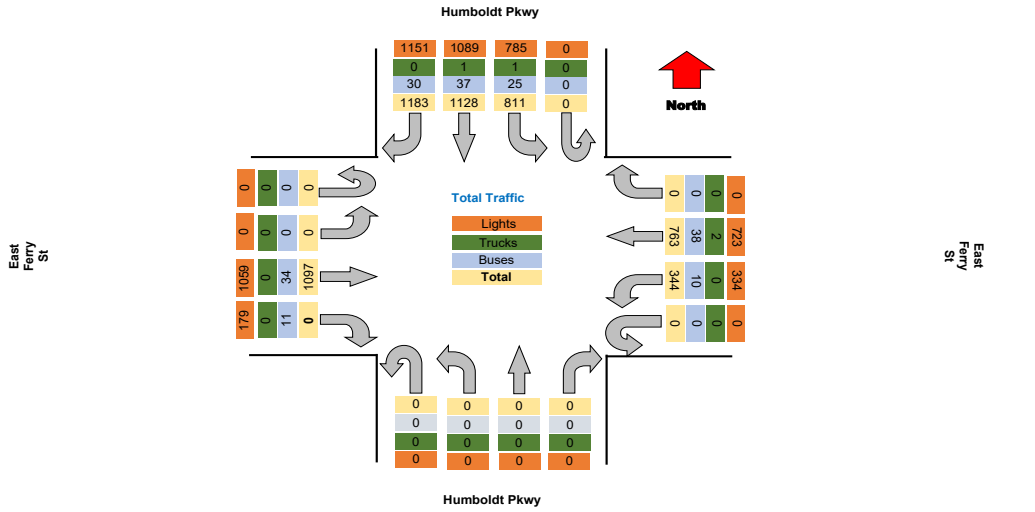

### Turning Movement Peak Hour Data (AM)

7:30:00 AM

Leg Direction	Humboldt Pkwy								East Ferry St								Humboldt Pkwy								East Ferry St								Total
	Southbound				Northbound				Westbound				Eastbound				Northbound				Eastbound												
Start Time	Right	Thru	Left	U-Turn	App Total	Peds CW	Peds CCW	Right	Thru	Left	U-Turn	App Total	Peds CW	Peds CCW	Right	Thru	Left	U-Turn	App Total	Peds CW	Peds CCW	Right	Thru	Left	U-Turn	App Total	Peds CW	Peds CCW					
7:30:00 AM	93	69	57	0	219	0	0	0	35	15	0	50	0	0	0	0	0	0	0	1	2	14	57	0	0	71	2	0	340				
7:45:00 AM	102	94	53	0	249	0	1	0	41	27	0	69	0	0	0	0	0	0	0	0	0	11	73	0	0	84	0	0	402				
8:00:00 AM	100	75	49	0	224	0	0	0	37	20	0	57	0	0	0	0	0	0	0	0	0	10	73	0	0	83	0	0	364				
8:15:00 AM	79	71	50	0	200	1	0	0	46	25	0	71	0	0	0	0	0	0	0	0	0	11	43	0	0	54	0	0	325				
<b>Grand Total</b>	<b>374</b>	<b>309</b>	<b>209</b>	<b>0</b>	<b>892</b>	<b>1</b>	<b>0</b>	<b>0</b>	<b>159</b>	<b>87</b>	<b>0</b>	<b>247</b>	<b>0</b>	<b>0</b>	<b>0</b>	<b>0</b>	<b>0</b>	<b>0</b>	<b>1</b>	<b>2</b>	<b>46</b>	<b>246</b>	<b>0</b>	<b>0</b>	<b>292</b>	<b>2</b>	<b>0</b>	<b>1431</b>					
% Approach	41.9%	34.6%	23.4%	0.0%	0.0%	0.0%	0.0%	14.2%	85.8%	0.0%	0.0%	0.0%	0.0%	0.0%	45.1%	41.7%	13.2%	0.0%	0.0%	0.0%	0.0%	0.0%	66.2%	33.8%	0.0%	0.0%	0.0%	0.0%	0.0%				
% Total	26.1%	21.6%	14.6%	0.0%	62.3%	0.0%	0.0%	0.0%	11.1%	6.1%	0.0%	17.3%	0.0%	0.0%	0.0%	0.0%	0.0%	0.0%	0.0%	0.0%	0.0%	3.2%	17.2%	0.0%	0.0%	20.4%	0.0%	0.0%	3.8%				
PHF	0.917	0.822	0.917	0.000	0.896	0.000	0.000	0.000	0.864	0.806	0.000	0.870	0.000	0.000	0.000	0.000	0.000	0.000	0.000	0.000	0.000	0.821	0.842	0.000	0.000	0.869	0.000	0.000	0.890				
Lights	362	296	206	0	864	0	0	0	149	82	0	231	0	0	0	0	0	0	0	0	0	43	235	0	0	278	0	0	1373				
% Lights	96.8%	95.8%	98.6%	0.0%	96.9%	0.0%	0.0%	0.0%	93.7%	94.3%	0.0%	93.5%	0.0%	0.0%	0.0%	0.0%	0.0%	0.0%	0.0%	0.0%	0.0%	93.5%	95.5%	0.0%	0.0%	95.2%	0.0%	0.0%	95.9%				
Trucks	0	1	0	0	1	0	0	0	1	0	0	1	0	0	0	0	0	0	0	0	0	0	0	0	0	0	0	0	2				
% Trucks	0.0%	0.3%	0.0%	0.0%	0.1%	0.0%	0.0%	0.0%	0.6%	0.0%	0.0%	0.4%	0.0%	0.0%	0.0%	0.0%	0.0%	0.0%	0.0%	0.0%	0.0%	0.0%	0.0%	0.0%	0.0%	0.0%	0.0%	0.1%					
Buses	12	12	3	0	27	0	0	0	9	5	0	14	0	0	0	0	0	0	0	0	0	3	11	0	0	14	0	0	56				
% Buses	3.2%	3.9%	1.4%	0.0%	0.0%	0.0%	0.0%	0.0%	5.7%	5.7%	0.0%	0.0%	0.0%	0.0%	0.0%	0.0%	0.0%	0.0%	0.0%	0.0%	0.0%	6.5%	4.5%	0.0%	0.0%	0.0%	0.0%	0.0%	3.8%				
Pedestrians	0	0	0	0	0	1	1	0	0	0	0	0	0	0	0	0	0	0	1	2	0	0	0	0	0	0	2	0	0				
% Pedestrians	0.0%	0.0%	0.0%	0.0%	0.0%	100.0%	100.0%	0.0%	0.0%	0.0%	0.0%	0.0%	0.0%	0.0%	0.0%	0.0%	0.0%	0.0%	0.0%	0.0%	0.0%	0.0%	0.0%	0.0%	0.0%	0.0%	0.0%	100.0%	0.0%				
Bicycles on Crosswalk	0	0	0	0	0	0	0	0	0	0	0	0	0	0	0	0	0	0	0	0	0	0	0	0	0	0	0	0	0				
% Bicycles on Crosswalk	0.0%	0.0%	0.0%	0.0%	0.0%	0.0%	0.0%	0.0%	0.0%	0.0%	0.0%	0.0%	0.0%	0.0%	0.0%	0.0%	0.0%	0.0%	0.0%	0.0%	0.0%	0.0%	0.0%	0.0%	0.0%	0.0%	0.0%	0.0%	0.0%				

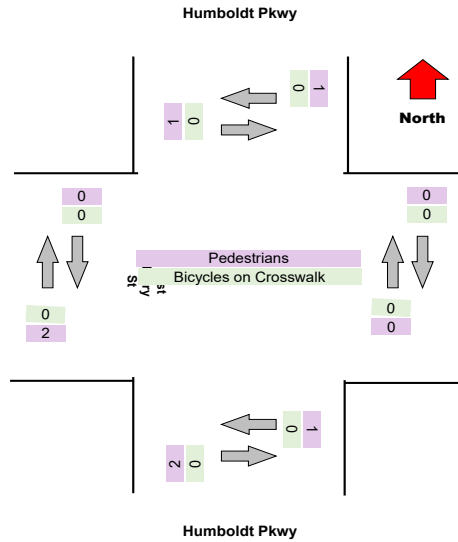
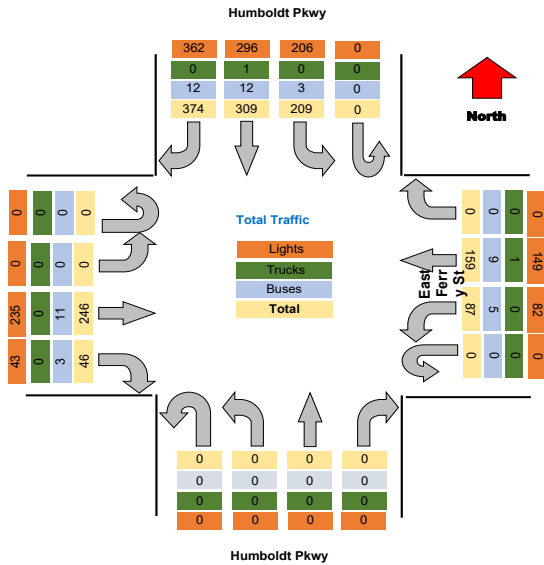



Project : VBH Malta NY  
Site : Site 4  
Location : 42.948550, -73.790036

TSTData.com

Survey Date : 2021-04-28, Wednesday

### Turning Movement Peak Hour Data (PM)

4:15:00 PM

Leg Direction	Humboldt Pkwy				East Ferry St				Humboldt Pkwy				East Ferry St				Total						
	Southbound		Northbound		Westbound		Eastbound		Northbound		Southbound		Eastbound										
Start Time	Right	Thru	Left	U-Turn	App Total	Peds CW	Peds CCW	Right	Thru	Left	U-Turn	App Total	Peds CW	Peds CCW	Right	Thru	Left	U-Turn	App Total	Peds CW	Peds CCW		
4:15:00 PM	86	95	73	0	254	0	0	0	69	36	0	105	0	0	0	0	0	0	0	110	0	1	469
4:30:00 PM	86	85	61	0	232	0	1	0	50	35	0	85	0	0	0	0	0	0	0	99	0	0	416
4:45:00 PM	77	79	61	0	217	0	1	0	75	23	0	98	0	0	0	0	0	0	0	106	0	0	421
5:00:00 PM	79	92	58	0	229	0	0	0	59	20	0	79	0	0	0	0	0	0	1	117	0	1	422
<b>Grand Total</b>	<b>328</b>	<b>351</b>	<b>253</b>	<b>0</b>	<b>932</b>	<b>0</b>	<b>1</b>	<b>0</b>	<b>250</b>	<b>114</b>	<b>0</b>	<b>364</b>	<b>0</b>	<b>0</b>	<b>0</b>	<b>0</b>	<b>0</b>	<b>0</b>	<b>1</b>	<b>54</b>	<b>368</b>	<b>0</b>	<b>432</b>
<b>% Approach</b>	35.2%	37.7%	27.1%	0.0%	<b>0.0%</b>	0.0%	0.0%	14.2%	85.8%	0.0%	0.0%	<b>0.0%</b>	0.0%	0.0%	45.1%	41.7%	13.2%	0.0%	<b>0.0%</b>	0.0%	0.0%	0.0%	0.0%
<b>% Total</b>	19.0%	20.3%	14.6%	0.0%	<b>53.9%</b>	0.0%	0.0%	0.0%	14.5%	6.6%	0.0%	<b>21.1%</b>	0.0%	0.0%	0.0%	0.0%	0.0%	0.0%	<b>0.0%</b>	0.0%	0.0%	0.0%	0.0%
<b>PHF</b>	0.953	0.924	0.866	0.000	<b>0.917</b>	0.000	0.000	0.000	0.833	0.792	0.000	<b>0.867</b>	0.000	0.000	0.000	0.000	0.000	0.000	<b>0.889</b>	0.876	0.000	0.000	<b>0.923</b>
<b>Lights</b>	319	337	244	0	<b>900</b>	0	0	0	242	112	0	<b>354</b>	0	0	0	0	0	0	<b>0</b>	59	360	0	<b>419</b>
<b>% Lights</b>	97.3%	96.0%	96.4%	0.0%	<b>96.6%</b>	0.0%	0.0%	0.0%	96.8%	98.2%	0.0%	<b>97.3%</b>	0.0%	0.0%	0.0%	0.0%	0.0%	0.0%	<b>0.0%</b>	92.2%	97.8%	0.0%	<b>97.0%</b>
<b>Trucks</b>	0	0	0	0	<b>0</b>	0	0	0	0	0	0	<b>0</b>	0	0	0	0	0	0	<b>0</b>	0	0	0	<b>0</b>
<b>% Trucks</b>	0.0%	0.0%	0.0%	0.0%	<b>0.0%</b>	0.0%	0.0%	0.0%	0.0%	0.0%	0.0%	<b>0.0%</b>	0.0%	0.0%	0.0%	0.0%	0.0%	0.0%	<b>0.0%</b>	0.0%	0.0%	0.0%	<b>0.0%</b>
<b>Buses</b>	9	13	9	0	<b>31</b>	0	0	0	8	2	0	<b>10</b>	0	0	0	0	0	0	<b>0</b>	5	6	0	<b>11</b>
<b>% Buses</b>	2.7%	3.7%	3.6%	0.0%	<b>0.0%</b>	0.0%	0.0%	0.0%	3.2%	1.8%	0.0%	<b>0.0%</b>	0.0%	0.0%	0.0%	0.0%	0.0%	0.0%	<b>0.0%</b>	7.8%	1.6%	0.0%	<b>0.0%</b>
<b>Pedestrians</b>	0	0	0	0	<b>0</b>	0	1	0	0	0	0	<b>0</b>	0	0	0	0	0	0	<b>2</b>	0	0	0	<b>0</b>
<b>% Pedestrians</b>	0.0%	0.0%	0.0%	0.0%	<b>0.0%</b>	0.0%	50.0%	0.0%	0.0%	0.0%	0.0%	<b>0.0%</b>	0.0%	0.0%	0.0%	0.0%	0.0%	0.0%	<b>0.0%</b>	100.0%	66.7%	0.0%	<b>0.0%</b>
<b>Bicycles on Crosswalk</b>	0	0	0	0	<b>0</b>	0	1	0	0	0	0	<b>0</b>	0	0	0	0	0	0	<b>1</b>	0	0	0	<b>0</b>
<b>% Bicycles on Crosswalk</b>	0.0%	0.0%	0.0%	0.0%	<b>0.0%</b>	0.0%	50.0%	0.0%	0.0%	0.0%	0.0%	<b>0.0%</b>	0.0%	0.0%	0.0%	0.0%	0.0%	0.0%	<b>0.0%</b>	0.0%	0.0%	0.0%	<b>0.0%</b>

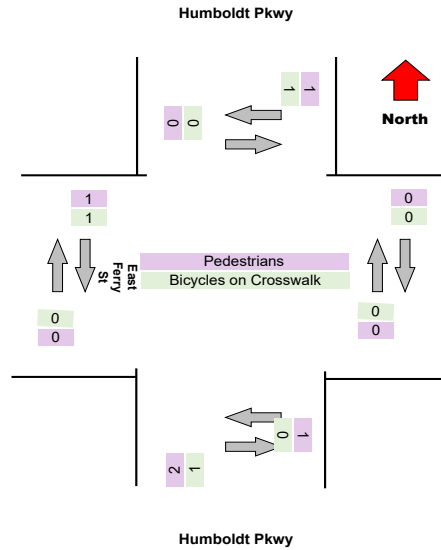
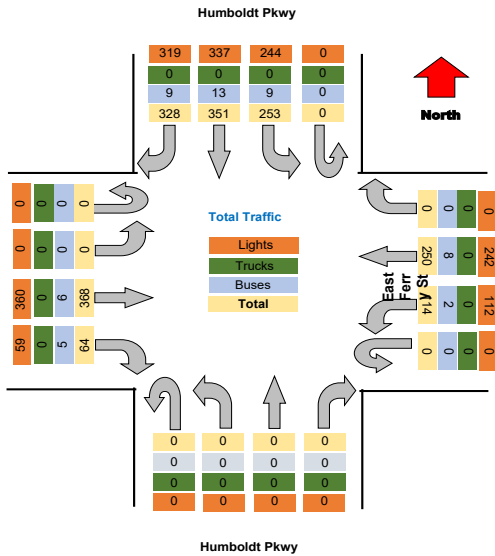



Project : VBH Malta NY  
 Site : Site 4  
 Location : 42.948550, -73.790036  
 Survey Date : 2021-04-28, Wednesday

**Turning Movement Data Plot**

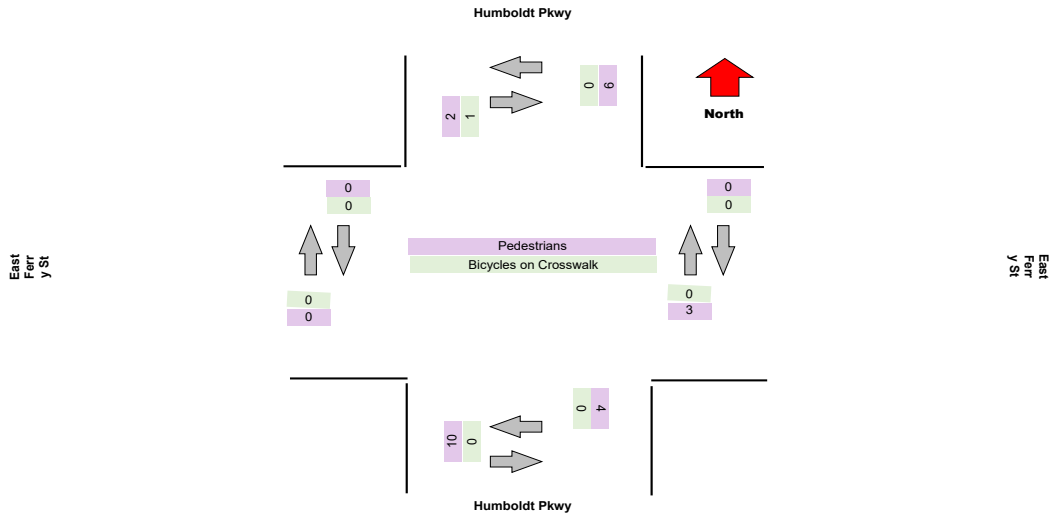
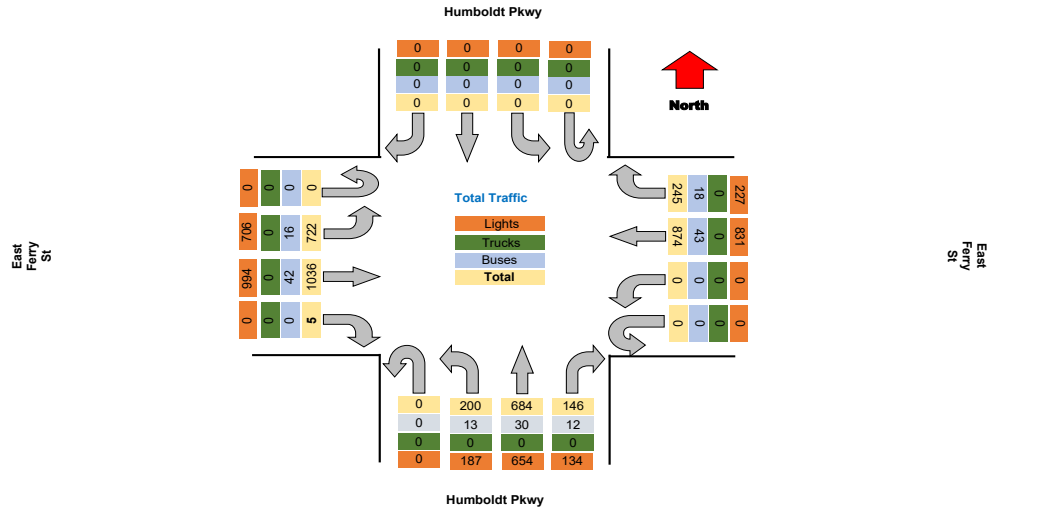

Project : VBH Malta NY  
Site : Site 4  
Location : 42.948550, -73.790036

TSTData.com

Survey Date : 2021-04-28, Wednesday

**Turning Movement Peak Hour Data (AM)**

7:30:00 AM

Leg Direction	Humboldt Pkwy							East Ferry St							Humboldt Pkwy							East Ferry St							Total
	Southbound				App Total			Westbound				App Total			Northbound				App Total			Eastbound							
Start Time	Right	Thru	Left	U-Turn	App Total	Peds CW	Peds CCW	Right	Thru	Left	U-Turn	App Total	Peds CW	Peds CCW	Right	Thru	Left	U-Turn	App Total	Peds CW	Peds CCW	Right	Thru	Left	U-Turn	App Total	Peds CW	Peds CCW	
7:30:00 AM	0	0	0	0	0	1	0	13	42	0	0	55	0	0	5	41	11	0	57	0	2	0	67	57	0	124	0	0	236
7:45:00 AM	0	0	0	0	0	1	1	11	47	0	0	59	0	0	11	53	7	0	71	1	1	0	71	45	0	116	0	0	246
8:00:00 AM	0	0	0	0	0	0	0	17	46	0	0	63	0	0	6	47	16	0	69	0	1	0	54	46	0	100	0	0	232
8:15:00 AM	0	0	0	0	0	1	1	15	70	0	0	86	0	0	11	43	12	0	66	0	0	0	50	40	0	90	0	0	242
Grand Total	0	0	0	0	0	3	2	56	205	0	0	253	0	0	33	194	46	0	253	1	4	0	242	183	0	430	3	0	956
% Approach	#DIV/0!	#DIV/0!	#DIV/0!	#DIV/0!	0.0%	0.0%	0.0%	14.2%	85.8%	0.0%	0.0%	0.0%	0.0%	0.0%	45.1%	41.7%	13.2%	0.0%	0.0%	0.0%	0.0%	0.0%	66.2%	33.8%	0.0%	0.0%	0.0%	0.0%	
% Total	0.0%	0.0%	0.0%	0.0%	0.0%	0.0%	0.0%	5.9%	21.4%	0.0%	0.0%	27.5%	0.0%	0.0%	3.5%	19.2%	4.8%	0.0%	27.5%	0.0%	0.0%	0.0%	25.3%	19.7%	0.0%	45.0%	0.0%	0.0%	
PHF	0.000	0.000	0.000	0.000	0.000	0.000	0.000	0.824	0.732	0.000	0.000	0.765	0.000	0.000	0.750	0.868	0.719	0.000	0.826	0.000	0.000	0.000	0.852	0.825	0.000	0.867	0.000	0.000	0.972
Lights	0	0	0	0	0	0	0	53	194	0	0	247	0	0	29	177	43	0	249	0	0	0	229	183	0	412	0	0	908
% Lights	0.0%	0.0%	0.0%	0.0%	0.0%	0.0%	0.0%	94.6%	94.6%	0.0%	0.0%	93.9%	0.0%	0.0%	87.9%	96.2%	93.5%	0.0%	94.7%	0.0%	0.0%	0.0%	94.6%	97.3%	0.0%	95.8%	0.0%	0.0%	95.0%
Trucks	0	0	0	0	0	0	0	0	0	0	0	0	0	0	0	0	0	0	0	0	0	0	0	0	0	0	0	0	0
% Trucks	0.0%	0.0%	0.0%	0.0%	0.0%	0.0%	0.0%	0.0%	0.0%	0.0%	0.0%	0.0%	0.0%	0.0%	0.0%	0.0%	0.0%	0.0%	0.0%	0.0%	0.0%	0.0%	0.0%	0.0%	0.0%	0.0%	0.0%	0.0%	0.0%
Buses	0	0	0	0	0	0	0	3	11	0	0	14	0	0	4	7	3	0	14	0	0	0	13	5	0	18	0	0	46
% Buses	0.0%	0.0%	0.0%	0.0%	0.0%	0.0%	0.0%	5.4%	5.4%	0.0%	0.0%	0.0%	0.0%	0.0%	12.1%	3.8%	6.5%	0.0%	0.0%	0.0%	0.0%	0.0%	5.4%	2.7%	0.0%	0.0%	0.0%	0.0%	4.8%
Pedestrians	0	0	0	0	0	2	2	0	0	0	0	0	0	0	0	0	0	0	1	4	0	0	0	0	0	0	0	0	0
% Pedestrians	0.0%	0.0%	0.0%	0.0%	0.0%	66.7%	100.0%	0.0%	0.0%	0.0%	0.0%	0.0%	0.0%	0.0%	0.0%	0.0%	0.0%	0.0%	0.0%	100.0%	100.0%	0.0%	0.0%	0.0%	0.0%	0.0%	0.0%	0.0%	0.0%
Bicycles on Crosswalk	0	0	0	0	0	1	0	0	0	0	0	0	0	0	0	0	0	0	0	0	0	0	0	0	0	0	0	0	0
% Bicycles on Crosswalk	0.0%	0.0%	0.0%	0.0%	0.0%	33.3%	0.0%	0.0%	0.0%	0.0%	0.0%	0.0%	0.0%	0.0%	0.0%	0.0%	0.0%	0.0%	0.0%	0.0%	0.0%	0.0%	0.0%	0.0%	0.0%	0.0%	0.0%	0.0%	0.0%

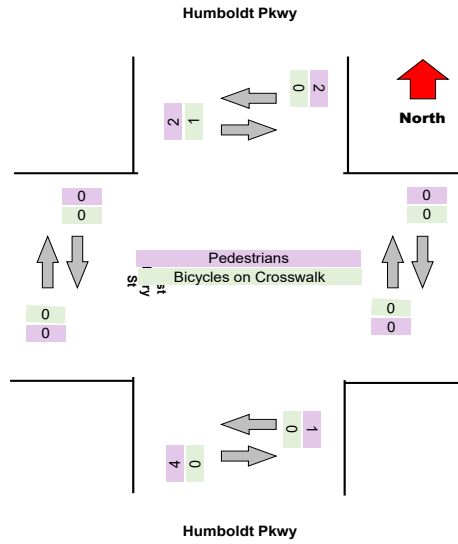
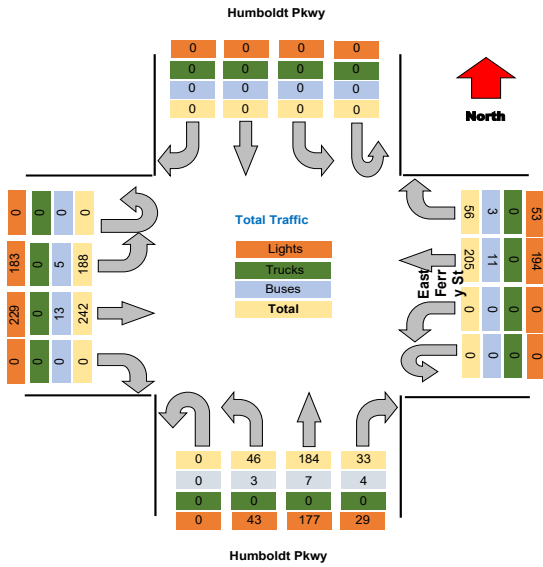

## Turning Movement Peak Hour Data (PM)

4:15:00 PM

Leg Direction	Humboldt Pkwy				East Ferry St				Humboldt Pkwy				East Ferry St				Total												
	Southbound				Westbound				Northbound				Eastbound																
Start Time	Right	Thru	Left	U-Turn	App Total	Peds CW	Peds CCW	Right	Thru	Left	U-Turn	App Total	Peds CW	Peds CCW	Right	Thru	Left	U-Turn	App Total	Peds CW	Peds CCW	Total							
4:15:00 PM	0	0	0	0	0	0	1	23	81	0	0	104	0	0	12	51	12	0	75	0	1	0	87	63	0	150	0	0	329
4:30:00 PM	0	0	0	0	0	0	0	22	81	0	0	103	0	0	15	51	11	0	77	0	1	0	106	44	0	150	0	0	330
4:45:00 PM	0	0	0	0	0	0	1	11	80	0	0	91	0	0	16	43	13	0	72	0	0	0	82	44	0	126	0	0	289
5:00:00 PM	0	0	0	0	0	0	2	18	73	0	0	91	0	0	10	44	20	0	74	0	1	0	77	56	0	133	0	0	238
<b>Grand Total</b>	<b>0</b>	<b>0</b>	<b>0</b>	<b>0</b>	<b>0</b>	<b>0</b>	<b>4</b>	<b>74</b>	<b>315</b>	<b>0</b>	<b>0</b>	<b>389</b>	<b>0</b>	<b>0</b>	<b>53</b>	<b>199</b>	<b>56</b>	<b>0</b>	<b>298</b>	<b>0</b>	<b>2</b>	<b>0</b>	<b>352</b>	<b>207</b>	<b>0</b>	<b>539</b>	<b>0</b>	<b>0</b>	<b>1246</b>
<b>% Approach</b>	#DIV/0!	#DIV/0!	#DIV/0!	#DIV/0!	0.0%	0.0%	0.0%	14.2%	85.8%	0.0%	0.0%	0.0%	0.0%	0.0%	45.1%	41.7%	13.2%	0.0%	0.0%	0.0%	0.0%	0.0%	66.2%	33.8%	0.0%	0.0%	0.0%	0.0%	0.0%
<b>% Total</b>	0.0%	0.0%	0.0%	0.0%	0.0%	0.0%	0.0%	5.9%	25.3%	0.0%	0.0%	31.2%	0.0%	0.0%	4.3%	15.2%	4.5%	0.0%	23.9%	0.0%	0.0%	0.0%	28.3%	16.6%	0.0%	44.9%	0.0%	0.0%	0.0%
<b>PHF</b>	0.000	0.000	0.000	0.000	0.000	0.000	0.000	0.804	0.972	0.000	0.000	0.935	0.000	0.000	0.828	0.926	0.700	0.000	0.868	0.000	0.000	0.000	0.830	0.821	0.000	0.932	0.000	0.000	0.944
<b>Lights</b>	0	0	0	0	0	0	0	71	301	0	0	372	0	0	50	177	53	0	280	0	0	0	340	205	0	545	0	0	1197
<b>% Lights</b>	0.0%	0.0%	0.0%	0.0%	0.0%	0.0%	0.0%	85.9%	95.6%	0.0%	0.0%	95.6%	0.0%	0.0%	84.3%	93.7%	94.6%	0.0%	94.0%	0.0%	0.0%	0.0%	96.6%	99.0%	0.0%	97.5%	0.0%	0.0%	96.1%
<b>Trucks</b>	0	0	0	0	0	0	0	0	0	0	0	0	0	0	0	0	0	0	0	0	0	0	0	0	0	0	0	0	0
<b>% Trucks</b>	0.0%	0.0%	0.0%	0.0%	0.0%	0.0%	0.0%	0.0%	0.0%	0.0%	0.0%	0.0%	0.0%	0.0%	0.0%	0.0%	0.0%	0.0%	0.0%	0.0%	0.0%	0.0%	0.0%	0.0%	0.0%	0.0%	0.0%	0.0%	0.0%
<b>Buses</b>	0	0	0	0	0	0	0	3	14	0	0	17	0	0	3	12	3	0	18	0	0	0	12	2	0	14	0	0	49
<b>% Buses</b>	0.0%	0.0%	0.0%	0.0%	0.0%	0.0%	0.0%	4.1%	4.4%	0.0%	0.0%	0.0%	0.0%	0.0%	5.7%	6.3%	5.4%	0.0%	0.0%	0.0%	0.0%	0.0%	3.4%	1.0%	0.0%	0.0%	0.0%	0.0%	3.9%
<b>Pedestrians</b>	0	0	0	0	0	4	0	0	0	0	0	0	0	0	0	0	0	0	3	0	0	0	0	0	0	0	0	0	0
<b>% Pedestrians</b>	0.0%	0.0%	0.0%	0.0%	0.0%	100.0%	0.0%	0.0%	0.0%	0.0%	0.0%	0.0%	0.0%	0.0%	0.0%	0.0%	0.0%	0.0%	0.0%	0.0%	0.0%	0.0%	0.0%	0.0%	0.0%	0.0%	0.0%	0.0%	0.0%
<b>Bicycles on Crosswalk</b>	0	0	0	0	0	0	0	0	0	0	0	0	0	0	0	0	0	0	0	0	0	0	0	0	0	0	0	0	0
<b>% Bicycles on Crosswalk</b>	0.0%	0.0%	0.0%	0.0%	0.0%	0.0%	0.0%	0.0%	0.0%	0.0%	0.0%	0.0%	0.0%	0.0%	0.0%	0.0%	0.0%	0.0%	0.0%	0.0%	0.0%	0.0%	0.0%	0.0%	0.0%	0.0%	0.0%	0.0%	0.0%

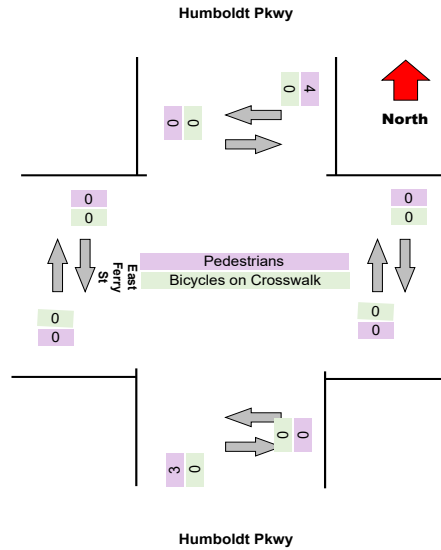
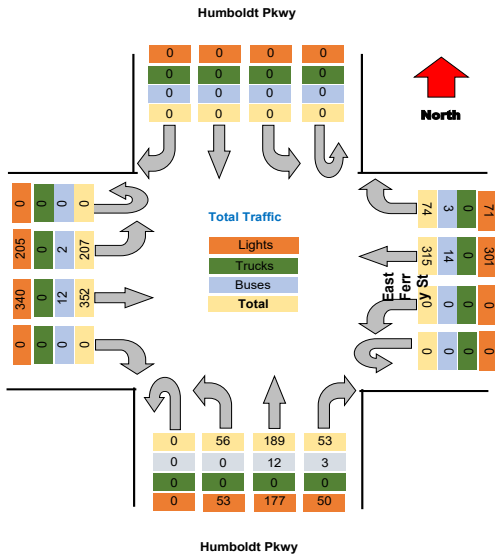



### Turning Movement Data Plot

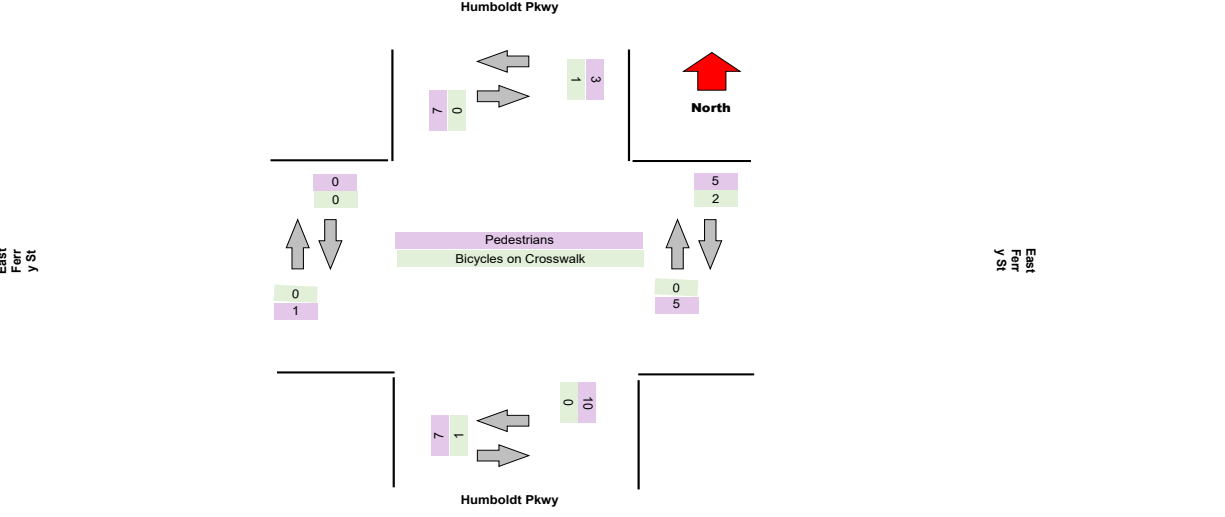
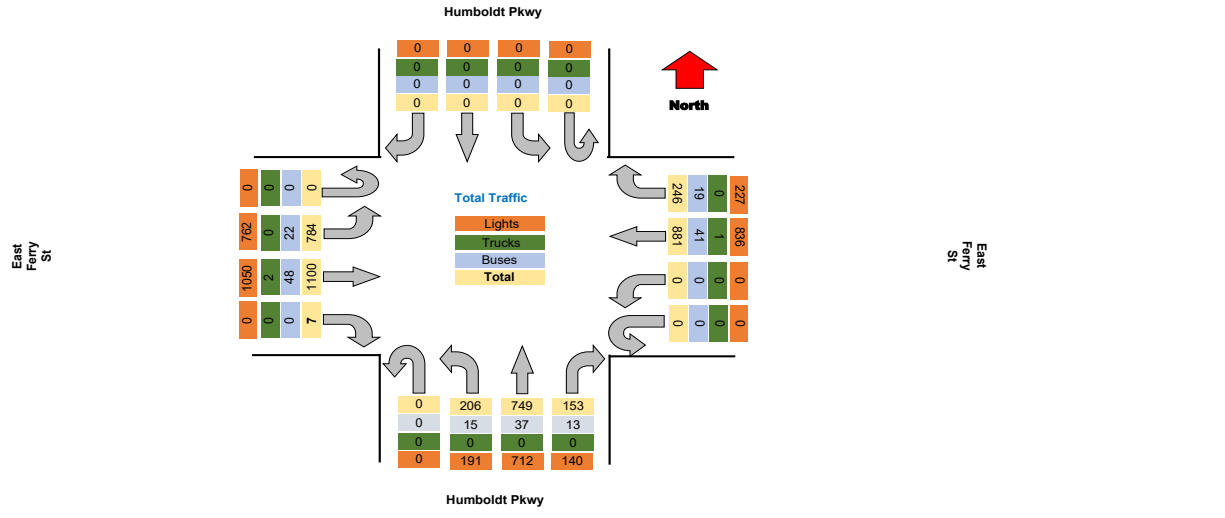

**Turning Movement Peak Hour Data (AM)**

7:30:00 AM

Leg Direction	Humboldt Pkwy							East Ferry St							Humboldt Pkwy							East Ferry St							Total
	Southbound				Westbound			Northbound				Eastbound			Northbound				Eastbound										
Start Time	Right	Thru	Left	U-Turn	App Total	Peds CW	Peds CCW	Right	Thru	Left	U-Turn	App Total	Peds CW	Peds CCW	Right	Thru	Left	U-Turn	App Total	Peds CW	Peds CCW	Right	Thru	Left	U-Turn	App Total	Peds CW	Peds CCW	
7:30:00 AM	0	0	0	0	0	0	0	15	37	0	0	52	1	0	7	45	10	0	63	1	1	0	62	54	0	116	0	0	231
7:45:00 AM	0	0	0	0	0	1	0	16	66	0	0	82	0	0	18	46	7	0	71	0	0	0	78	42	0	120	0	0	273
8:00:00 AM	0	0	0	0	0	0	0	10	52	0	0	62	0	0	9	54	18	0	81	0	0	0	66	44	0	110	0	0	253
8:15:00 AM	0	0	0	0	0	0	0	15	58	0	0	73	0	0	8	27	11	0	47	0	0	0	57	38	0	95	0	0	215
Grand Total	0	0	0	0	0	1	0	56	213	0	0	259	1	0	43	172	46	0	252	1	1	0	253	178	0	441	3	0	972
% Approach	#DIV/0!	#DIV/0!	#DIV/0!	#DIV/0!	0.0%	0.0%	0.0%	14.2%	85.8%	0.0%	0.0%	0.0%	0.0%	0.0%	45.1%	41.7%	13.2%	0.0%	0.0%	0.0%	0.0%	0.0%	66.2%	33.8%	0.0%	0.0%	0.0%	0.0%	
% Total	0.0%	0.0%	0.0%	0.0%	0.0%	0.0%	0.0%	5.8%	21.9%	0.0%	0.0%	27.0%	0.0%	0.0%	4.4%	17.7%	4.7%	0.0%	27.0%	0.0%	0.0%	0.0%	27.1%	18.3%	0.0%	45.4%	0.0%	0.0%	
PHF	0.000	0.000	0.000	0.000	0.000	0.000	0.000	0.875	0.807	0.000	0.000	0.820	0.000	0.000	0.597	0.796	0.639	0.000	0.809	0.000	0.000	0.000	0.843	0.824	0.000	0.919	0.000	0.000	
Lights	0	0	0	0	0	0	0	53	200	0	0	253	0	0	39	165	42	0	246	0	0	0	251	171	0	422	0	0	
% Lights	0.0%	0.0%	0.0%	0.0%	0.0%	0.0%	0.0%	94.6%	93.9%	0.0%	0.0%	94.1%	0.0%	0.0%	90.7%	95.0%	91.3%	0.0%	93.9%	0.0%	0.0%	0.0%	95.4%	96.1%	0.0%	95.7%	0.0%	0.0%	
Trucks	0	0	0	0	0	0	0	0	1	0	0	1	0	0	0	0	0	0	0	0	0	0	0	0	0	0	0	0	
% Trucks	0.0%	0.0%	0.0%	0.0%	0.0%	0.0%	0.0%	0.0%	0.5%	0.0%	0.0%	0.4%	0.0%	0.0%	0.0%	0.0%	0.0%	0.0%	0.0%	0.0%	0.0%	0.0%	0.0%	0.0%	0.0%	0.0%	0.0%	0.0%	
Buses	0	0	0	0	0	0	0	3	12	0	0	15	0	0	4	7	4	0	15	0	0	0	12	7	0	19	0	0	
% Buses	0.0%	0.0%	0.0%	0.0%	0.0%	0.0%	0.0%	5.4%	5.6%	0.0%	0.0%	0.0%	0.0%	0.0%	9.3%	4.1%	8.7%	0.0%	0.0%	0.0%	0.0%	0.0%	4.8%	3.9%	0.0%	0.0%	0.0%	0.0%	
Pedestrians	0	0	0	0	0	1	0	0	0	0	0	1	0	0	0	0	0	0	1	1	0	0	0	0	0	0	0	0	
% Pedestrians	0.0%	0.0%	0.0%	0.0%	0.0%	100.0%	0.0%	0.0%	0.0%	0.0%	0.0%	0.0%	100.0%	0.0%	0.0%	0.0%	0.0%	0.0%	0.0%	100.0%	100.0%	0.0%	0.0%	0.0%	0.0%	0.0%	0.0%	0.0%	
Bicycles on Crosswalk	0	0	0	0	0	0	0	0	0	0	0	0	0	0	0	0	0	0	0	0	0	0	0	0	0	0	0	0	
% Bicycles on Crosswalk	0.0%	0.0%	0.0%	0.0%	0.0%	0.0%	0.0%	0.0%	0.0%	0.0%	0.0%	0.0%	0.0%	0.0%	0.0%	0.0%	0.0%	0.0%	0.0%	0.0%	0.0%	0.0%	0.0%	0.0%	0.0%	0.0%	0.0%	0.0%	

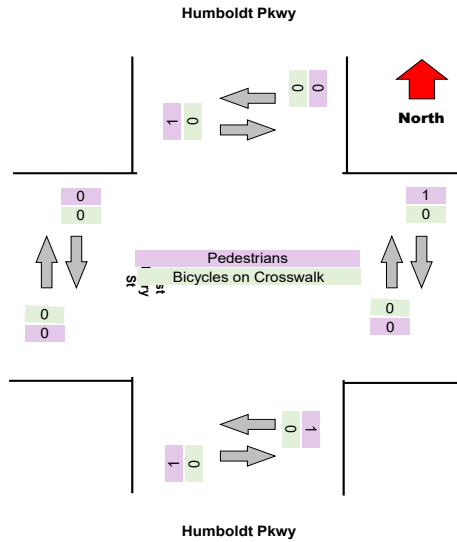
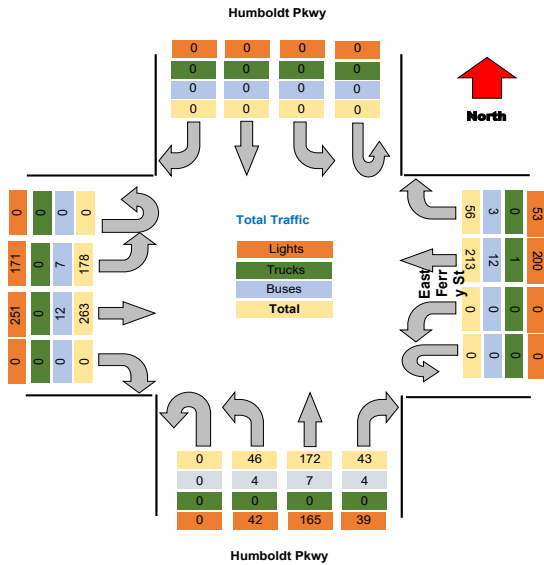



Project : VBH Malta NY  
Site : Site 4  
Location : 42.948550, -73.790036

TSTData.com

Survey Date : 2021-04-28, Wednesday

**Turning Movement Peak Hour Data (PM)**

4:15:00 PM

Leg Direction	Humboldt Pkwy						East Ferry St						Humboldt Pkwy						East Ferry St						Total	
	Southbound			Northbound			Westbound			Eastbound			Northbound			Eastbound										
Start Time	Right	Thru	Left	U-Turn	App Total	Peds CW	Peds CCW	Right	Thru	Left	U-Turn	App Total	Peds CW	Peds CCW	Right	Thru	Left	U-Turn	App Total	Peds CW	Peds CCW	Total				
4:15:00 PM	0	0	0	0	0	0	0	22	81	0	0	103	3	0	14	57	27	0	98	4	4	190	0	0	391	
4:30:00 PM	0	0	0	0	0	0	0	12	77	0	0	89	0	1	7	69	11	0	87	0	0	159	0	0	335	
4:45:00 PM	0	0	0	0	0	0	0	17	76	0	0	93	2	0	11	53	14	0	78	0	1	140	1	0	311	
5:00:00 PM	0	0	0	0	0	0	0	27	62	0	0	109	0	0	14	48	16	0	78	2	0	132	0	0	319	
Grand Total	0	0	0	0	0	0	0	78	316	0	0	394	5	1	46	227	68	0	341	6	5	621	1	0	1356	
% Approach	#DIV/0!	#DIV/0!	#DIV/0!	#DIV/0!	0.0%	0.0%	0.0%	14.2%	85.8%	0.0%	0.0%	0.0%	0.0%	0.0%	45.1%	41.7%	13.2%	0.0%	0.0%	0.0%	0.0%	0.0%	0.0%	0.0%	0.0%	
% Total	0.0%	0.0%	0.0%	0.0%	0.0%	0.0%	0.0%	5.8%	23.3%	0.0%	0.0%	29.1%	0.0%	0.0%	3.4%	16.7%	5.0%	0.0%	25.1%	0.0%	0.0%	0.0%	0.0%	0.0%	0.0%	
PHF	0.000	0.000	0.000	0.000	0.000	0.000	0.000	0.722	0.963	0.000	0.000	0.904	0.000	0.000	0.821	0.822	0.630	0.000	0.870	0.000	0.000	0.000	0.000	0.000	0.867	
Lights	0	0	0	0	0	0	0	75	303	0	0	378	0	0	42	211	63	0	316	0	0	603	0	0	1297	
% Lights	0.0%	0.0%	0.0%	0.0%	0.0%	0.0%	0.0%	96.2%	95.9%	0.0%	0.0%	95.9%	0.0%	0.0%	81.3%	93.0%	92.6%	0.0%	92.7%	0.0%	0.0%	96.3%	98.1%	0.0%	97.1%	
Trucks	0	0	0	0	0	0	0	0	0	0	0	0	0	0	0	0	0	0	0	0	0	0	0	0	0	
% Trucks	0.0%	0.0%	0.0%	0.0%	0.0%	0.0%	0.0%	0.0%	0.0%	0.0%	0.0%	0.0%	0.0%	0.0%	0.0%	0.0%	0.0%	0.0%	0.0%	0.0%	0.0%	0.0%	0.0%	0.0%	0.0%	
Buses	0	0	0	0	0	0	0	3	11	0	0	14	0	0	4	16	5	0	25	0	0	13	5	0	57	
% Buses	0.0%	0.0%	0.0%	0.0%	0.0%	0.0%	0.0%	3.8%	3.5%	0.0%	0.0%	3.8%	0.0%	0.0%	8.7%	7.0%	7.4%	0.0%	0.0%	0.0%	3.7%	1.9%	0.0%	0.0%	4.2%	
Pedestrians	0	0	0	0	0	0	0	0	0	0	0	3	1	1	0	0	0	0	6	6	4	0	0	0	1	
% Pedestrians	0.0%	0.0%	0.0%	0.0%	0.0%	0.0%	0.0%	0.0%	0.0%	0.0%	0.0%	0.8%	60.0%	100.0%	0.0%	0.0%	0.0%	0.0%	0.0%	0.0%	0.0%	0.0%	0.0%	0.0%	0.0%	0.0%
Bicycles on Crosswalk	0	0	0	0	0	0	0	0	0	0	0	2	0	0	0	0	0	0	0	0	1	0	0	0	0	
% Bicycles on Crosswalk	0.0%	0.0%	0.0%	0.0%	0.0%	0.0%	0.0%	0.0%	0.0%	0.0%	0.0%	0.0%	40.0%	0.0%	0.0%	0.0%	0.0%	0.0%	0.0%	0.0%	0.0%	20.0%	0.0%	0.0%	0.0%	0.0%

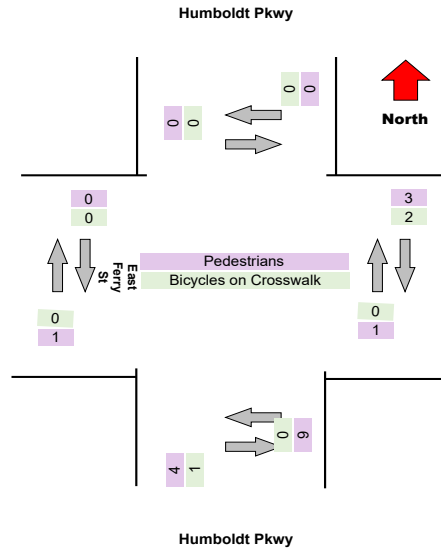
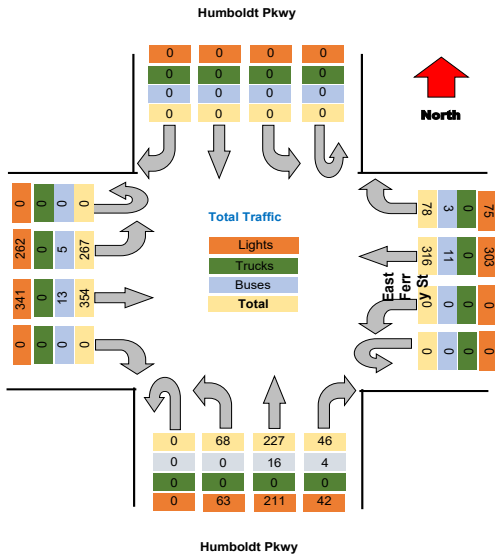



Project : VBH Malta NY  
 Site : Site 4  
 Location : 42.948550, -73.790036  
 Survey Date : 2021-04-28, Wednesday

### Turning Movement Data Plot

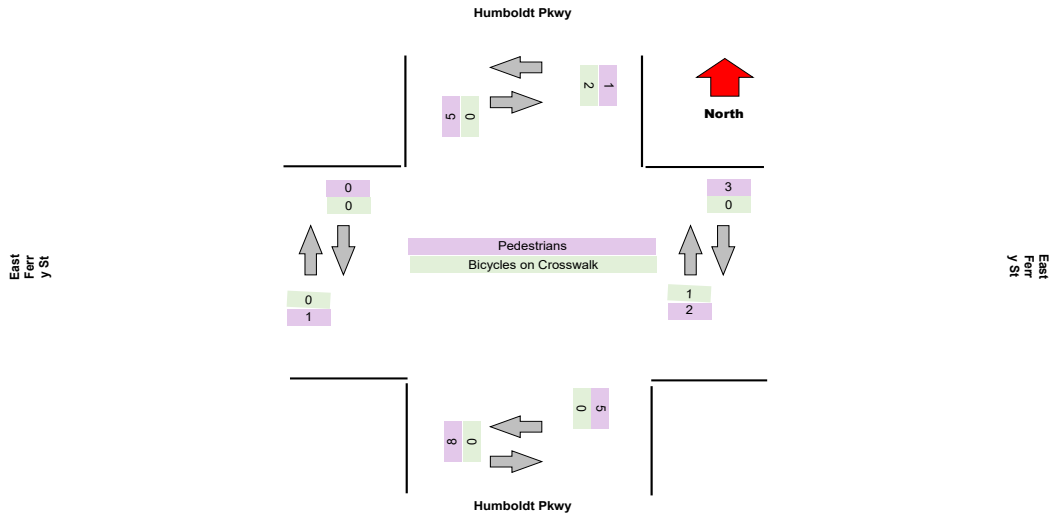
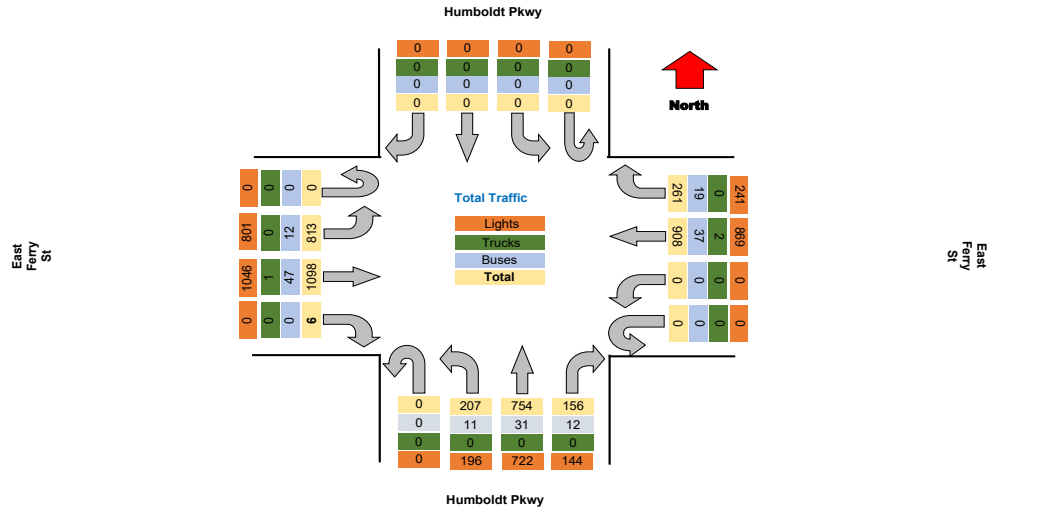

### Turning Movement Peak Hour Data (AM)

7:30:00 AM

Leg Direction	Humboldt Pkwy								East Ferry St								Humboldt Pkwy								East Ferry St								Total				
	Southbound				Northbound				Westbound				Eastbound				Northbound				Eastbound																
Start Time	Right	Thru	Left	U-Turn	App Total	Peds CW	Peds CCW		Right	Thru	Left	U-Turn	App Total	Peds CW	Peds CCW		Right	Thru	Left	U-Turn	App Total	Peds CW	Peds CCW		Right	Thru	Left	U-Turn	App Total	Peds CW	Peds CCW						
7:30:00 AM	0	0	0	0	0	0	0		21	41	0	0	62	0	0		6	39	12	0	57	0	2		0	61	57	0	118	0	0		237				
7:45:00 AM	0	0	0	0	0	0	0		14	53	0	0	67	0	0		12	58	10	0	80	0	0		0	65	56	0	121	0	0		268				
8:00:00 AM	0	0	0	0	0	0	0		13	49	0	0	62	0	0		8	53	12	0	73	0	0		0	76	49	0	125	0	0		260				
8:15:00 AM	0	0	0	0	0	0	0		13	64	0	0	78	0	0		11	32	8	0	51	0	0		0	52	44	0	96	0	0		225				
Grand Total	0	0	0	0	0	0	0		61	207	0	0	269	0	0		37	192	42	0	281	0	2		0	254	206	0	460	0	0		990				
% Approach	#DIV/0!	#DIV/0!	#DIV/0!	#DIV/0!	0.0%	0.0%	0.0%		14.2%	85.8%	0.0%	0.0%	0.0%	0.0%	0.0%		45.1%	41.7%	13.2%	0.0%	0.0%	0.0%	0.0%		0.0%	66.2%	33.8%	0.0%	0.0%	0.0%	0.0%						
% Total	0.0%	0.0%	0.0%	0.0%	0.0%	0.0%	0.0%		6.2%	20.9%	0.0%	0.0%	27.2%	0.0%	0.0%		3.7%	18.4%	4.2%	0.0%	26.4%	0.0%	0.0%		0.0%	25.7%	20.8%	0.0%	46.5%	0.0%	0.0%						
PHF	0.000	0.000	0.000	0.000	0.000	0.000	0.000		0.726	0.809	0.000	0.000	0.882	0.000	0.000		0.771	0.784	0.875	0.000	0.816	0.000	0.000		0.000	0.836	0.904	0.000	0.920	0.000	0.000		0.924				
Lights	0	0	0	0	0	0	0		58	196	0	0	254	0	0		34	174	38	0	246	0	0		0	245	201	0	446	0	0		946				
% Lights	0.0%	0.0%	0.0%	0.0%	0.0%	0.0%	0.0%		95.1%	94.7%	0.0%	0.0%	94.4%	0.0%	0.0%		81.9%	95.6%	90.5%	0.0%	94.3%	0.0%	0.0%		0.0%	96.5%	97.6%	0.0%	97.0%	0.0%	0.0%		95.6%				
Trucks	0	0	0	0	0	0	0		0	1	0	0	1	0	0		0	0	0	0	0	0	0	0	0	0	0	0	0	0	0	0	0	0	0		1
% Trucks	0.0%	0.0%	0.0%	0.0%	0.0%	0.0%	0.0%		0.0%	0.5%	0.0%	0.0%	0.4%	0.0%	0.0%		0.0%	0.0%	0.0%	0.0%	0.0%	0.0%	0.0%	0.0%	0.0%	0.0%	0.0%	0.0%	0.0%	0.0%	0.0%		0.1%				
Buses	0	0	0	0	0	0	0		3	10	0	0	13	0	0		3	8	4	0	15	0	0		0	9	5	0	14	0	0		42				
% Buses	0.0%	0.0%	0.0%	0.0%	0.0%	0.0%	0.0%		4.9%	4.8%	0.0%	0.0%	0.0%	0.0%	0.0%		8.1%	4.4%	9.5%	0.0%	0.0%	0.0%	0.0%		0.0%	3.5%	2.4%	0.0%	0.0%	0.0%	0.0%		4.2%				
Pedestrians	0	0	0	0	0	1	0		0	0	0	0	0	0	0		0	0	0	0	0	0	2	0	0	0	0	0	0	0	0	0	0	0	0		0
% Pedestrians	0.0%	0.0%	0.0%	0.0%	0.0%	100.0%	0.0%		0.0%	0.0%	0.0%	0.0%	0.0%	0.0%	0.0%		0.0%	0.0%	0.0%	0.0%	0.0%	0.0%	100.0%		0.0%	0.0%	0.0%	0.0%	0.0%	0.0%	0.0%		0.0%				
Bicycles on Crosswalk	0	0	0	0	0	1	0		0	0	0	0	0	0	0		0	0	0	0	0	0	0	0	0	0	0	0	0	0	0	0	0	0	0		0
% Bicycles on Crosswalk	0.0%	0.0%	0.0%	0.0%	0.0%	100.0%	0.0%		0.0%	0.0%	0.0%	0.0%	0.0%	0.0%	0.0%		0.0%	0.0%	0.0%	0.0%	0.0%	0.0%	0.0%		0.0%	0.0%	0.0%	0.0%	0.0%	0.0%	0.0%		0.0%				

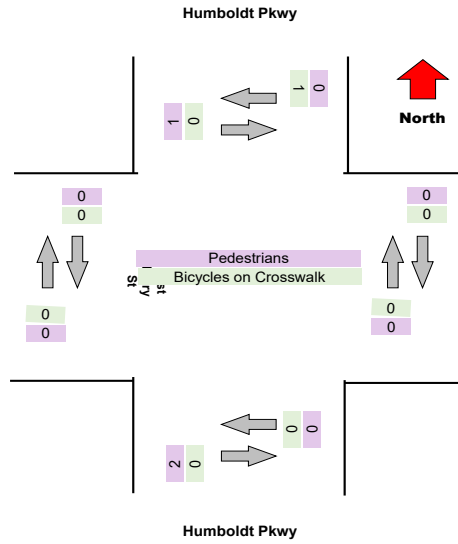
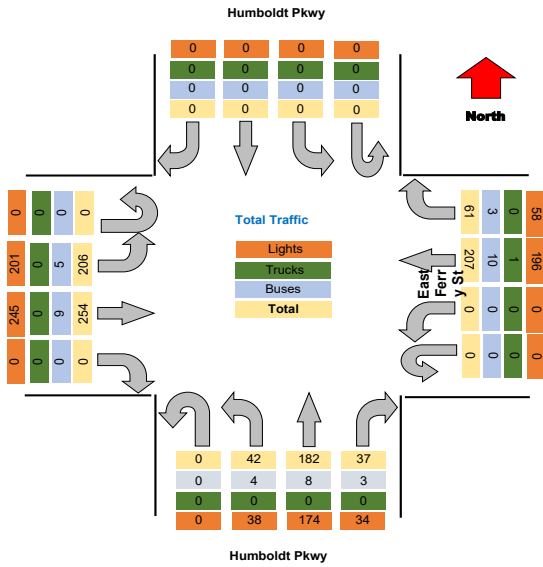

### Turning Movement Peak Hour Data (PM)

4:15:00 PM

Leg Direction	Humboldt Pkwy				East Ferry St				Humboldt Pkwy				East Ferry St				Total													
	Southbound		Northbound		Westbound		Eastbound		Northbound		Southbound		Eastbound																	
	Right	Thru	Left	U-Turn	App Total	Peds C/W	Bicy C/W	Right	Thru	Left	U-Turn	App Total	Peds C/W	Bicy C/W	Right	Thru		Left	U-Turn	App Total	Peds C/W	Bicy C/W								
4:15:00 PM	0	0	0	0	0	2	0	0	17	75	0	0	92	1	0	19	60	29	0	108	0	1	0	90	79	0	169	0	0	369
4:30:00 PM	0	0	0	0	0	0	0	0	18	75	0	0	93	0	1	11	54	14	0	79	0	1	0	94	53	0	147	0	0	319
4:45:00 PM	0	0	0	0	0	0	1	0	20	79	0	0	99	0	0	12	57	13	0	82	0	0	0	85	63	0	148	0	0	329
5:00:00 PM	0	0	0	0	0	0	0	0	21	69	0	0	90	1	0	14	56	11	0	80	0	0	0	89	74	0	162	0	0	342
Grand Total	0	0	0	0	0	2	1	0	76	298	0	0	374	2	1	55	236	67	0	359	0	2	0	357	269	0	626	2	0	1389
% Approach	#DIV/0!	#DIV/0!	#DIV/0!	#DIV/0!	0.0%	0.0%	0.0%	0.0%	14.2%	85.8%	0.0%	0.0%	0.0%	0.0%	0.0%	45.1%	41.7%	13.2%	0.0%	0.0%	0.0%	0.0%	0.0%	66.2%	33.8%	0.0%	0.0%	0.0%	0.0%	
% Total	0.0%	0.0%	0.0%	0.0%	0.0%	0.0%	0.0%	0.0%	5.6%	21.9%	0.0%	0.0%	27.5%	0.0%	0.0%	4.1%	17.4%	4.9%	0.0%	26.4%	0.0%	0.0%	0.0%	26.3%	19.8%	0.0%	46.1%	0.0%	0.0%	
PHF	0.000	0.000	0.000	0.000	0.000	0.000	0.000	0.000	0.905	0.943	0.000	0.000	0.944	0.000	0.000	0.737	0.908	0.578	0.000	0.831	0.000	0.000	0.000	0.949	0.851	0.000	0.926	0.000	0.000	0.921
Lights	0	0	0	0	0	0	0	0	72	289	0	0	361	0	0	52	224	65	0	341	0	0	0	342	266	0	608	0	0	1310
% Lights	0.0%	0.0%	0.0%	0.0%	0.0%	0.0%	0.0%	0.0%	84.7%	97.0%	0.0%	0.0%	96.5%	0.0%	0.0%	82.9%	94.9%	97.0%	0.0%	95.0%	0.0%	0.0%	0.0%	95.8%	98.9%	0.0%	97.1%	0.0%	0.0%	96.4%
Trucks	0	0	0	0	0	0	0	0	0	0	0	0	0	0	0	0	0	0	0	0	0	0	0	0	0	0	0	0	0	0
% Trucks	0.0%	0.0%	0.0%	0.0%	0.0%	0.0%	0.0%	0.0%	0.0%	0.0%	0.0%	0.0%	0.0%	0.0%	0.0%	0.0%	0.0%	0.0%	0.0%	0.0%	0.0%	0.0%	0.0%	0.0%	0.0%	0.0%	0.0%	0.0%	0.0%	0.0%
Buses	0	0	0	0	0	0	0	0	4	9	0	0	13	0	0	4	11	2	0	17	0	0	0	13	3	0	16	0	0	46
% Buses	0.0%	0.0%	0.0%	0.0%	0.0%	0.0%	0.0%	0.0%	5.3%	3.0%	0.0%	0.0%	3.5%	0.0%	0.0%	7.1%	4.7%	3.0%	0.0%	4.7%	0.0%	0.0%	0.0%	3.8%	1.1%	0.0%	0.0%	0.0%	0.0%	3.4%
Pedestrians	0	0	0	0	0	2	0	0	0	0	0	0	2	1	0	0	0	0	0	2	0	0	0	0	0	0	0	0	0	0
% Pedestrians	0.0%	0.0%	0.0%	0.0%	0.0%	100.0%	0.0%	0.0%	0.0%	0.0%	0.0%	0.0%	0.5%	100.0%	100.0%	0.0%	0.0%	0.0%	0.0%	0.6%	0.0%	0.0%	0.0%	0.0%	0.0%	0.0%	0.0%	0.0%	0.0%	0.0%
Bicycles on Crosswalk	0	0	0	0	0	1	0	0	0	0	0	0	0	0	0	0	0	0	0	0	0	0	0	0	0	0	0	0	0	0
% Bicycles on Crosswalk	0.0%	0.0%	0.0%	0.0%	0.0%	0.0%	100.0%	0.0%	0.0%	0.0%	0.0%	0.0%	0.0%	0.0%	0.0%	0.0%	0.0%	0.0%	0.0%	0.0%	0.0%	0.0%	0.0%	0.0%	0.0%	0.0%	0.0%	0.0%	0.0%	0.0%

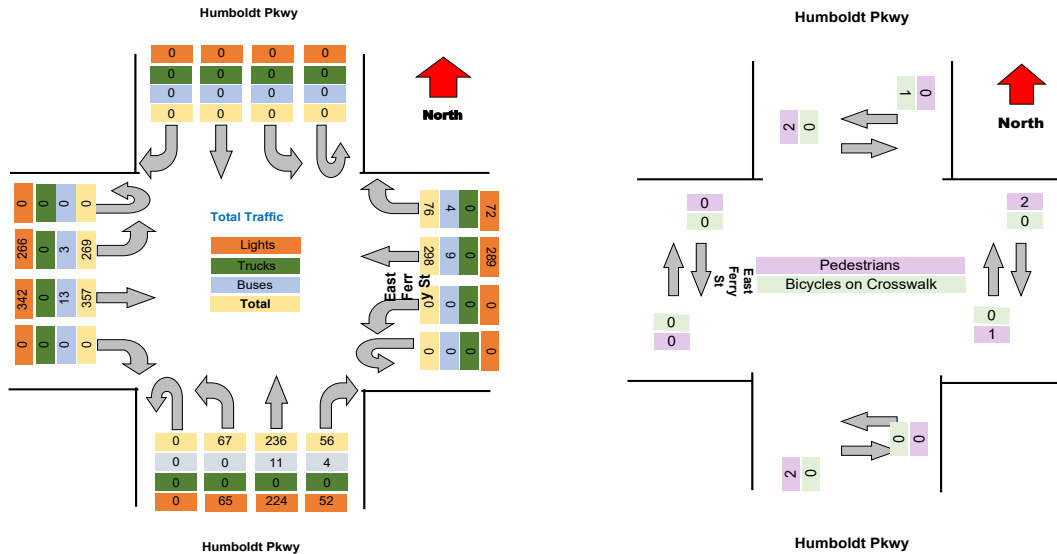

Project : VBH Malta NY  
 Site : Site 4  
 Location : 42.948550, -73.790036

TSTData.com

Survey Date : 2021-04-28, Wednesday

Project	LaBella
Project Code	LaBella
Site Name	10
Legs and Movements	All Processed Legs & Move
Bin Size	15 minutes
Survey Date	2021-11-02, Tuesday
Location	10
Latitude and Longitude	42.896936, -78.853849

	Start	End	PHF
Forced Peak AM	2021/11/02 07:30:00	2021/11/02 08:30:00	0.92
Forced Peak PM	2021/11/02 16:30:00	2021/11/02 17:30:00	0.97
AM Peak	2021/11/02 07:30:00	2021/11/02 08:30:00	0.92
PM Peak	2021/11/02 16:15:00	2021/11/02 17:15:00	0.97

### Turning Movement Data

Leg Direction	Jefferson Ave										Fruit Belt										Jefferson Ave										Cherry St										Total
	Southbound					Westbound					Northbound					Eastbound																									
	Right	Thru	Left	U-Turn	App Total	Peds CV	Peds CCV	Right	Thru	Left	U-Turn	App Total	Peds CV	Peds CCV	Right	Thru	Left	U-Turn	App Total	Peds CV	Peds CCV	Right	Thru	Left	U-Turn	App Total	Peds CV	Peds CCV													
Start Time																																									
6:30:00 AM	0	42	12	0	54	0	0	0	0	0	0	0	0	0	13	34	0	0	47	0	0	0	2	3	0	5	0	1	106												
6:45:00 AM	0	40	13	0	53	0	0	0	0	0	0	0	0	15	42	0	0	57	0	0	0	0	0	0	0	0	0	0	110												
Hourly Total	0	82	25	0	107	0	0	0	0	0	0	0	0	28	76	0	0	104	0	0	0	2	3	0	5	0	1	216													
7:00:00 AM	0	54	28	0	82	0	0	0	0	0	0	0	11	27	31	0	0	59	0	0	0	0	0	0	0	0	0	141													
7:15:00 AM	0	59	12	0	71	0	0	0	0	0	0	0	0	30	34	0	0	64	0	0	0	1	1	0	2	0	0	137													
7:30:00 AM	0	56	25	0	81	0	0	0	0	0	0	0	0	37	57	0	0	94	0	0	0	0	1	3	0	4	1	179													
7:45:00 AM	0	73	16	0	89	0	0	0	0	0	0	0	0	34	42	0	0	76	0	0	0	0	1	1	0	2	0	167													
Hourly Total	0	242	81	0	323	0	0	0	0	0	0	1	1	128	164	0	0	293	0	0	0	1	3	4	0	8	1	3	624												
8:00:00 AM	0	81	20	0	101	0	0	0	0	0	0	0	0	31	57	0	0	88	0	0	0	0	1	3	0	4	0	1	193												
8:15:00 AM	0	86	16	0	102	0	0	0	0	0	0	1	1	21	41	0	0	64	0	0	0	0	1	3	0	4	0	0	170												
Hourly Total	0	167	36	0	203	0	0	0	0	0	0	1	1	52	98	0	0	152	0	0	0	0	2	6	0	8	0	1	363												
4:00:00 PM	0	131	66	0	197	0	0	0	0	0	0	0	0	55	66	0	0	121	0	0	0	0	3	3	0	6	1	1	324												
4:15:00 PM	0	134	72	0	206	0	1	0	0	0	0	1	1	65	53	0	0	118	1	0	0	1	1	0	0	2	1	1	326												
4:30:00 PM	1	147	80	0	228	0	0	0	0	0	0	2	2	62	53	0	0	115	0	0	0	0	0	5	0	0	0	348													
4:45:00 PM	0	137	69	0	206	0	1	0	0	0	0	0	0	44	70	0	0	114	0	0	0	0	0	4	0	4	2	1	324												
Hourly Total	1	549	287	0	837	0	2	0	0	0	0	1	5	228	282	0	0	468	1	0	0	1	4	12	0	17	4	3	1322												
5:00:00 PM	0	117	83	0	200	0	0	0	0	0	0	0	0	64	81	0	0	145	0	0	0	0	0	2	0	2	0	0	347												
5:15:00 PM	0	143	69	0	212	0	0	0	0	0	0	1	1	70	66	0	0	136	0	0	0	1	1	3	0	5	0	0	353												
5:30:00 PM	0	133	50	0	183	0	0	0	0	0	0	0	2	38	69	0	0	107	0	1	0	1	0	3	0	4	0	1	294												
5:45:00 PM	0	120	42	0	162	0	0	0	0	0	0	0	0	51	66	0	0	117	0	0	0	0	2	1	0	3	1	0	282												
Hourly Total	0	513	244	0	757	0	0	0	0	0	0	1	3	223	282	0	0	505	0	1	0	2	3	9	0	14	1	1	1276												
Grand Total	1	1553	673	0	2227	0	2	0	0	0	0	3	10	657	862	0	0	1522	1	1	0	4	14	34	0	52	6	9	3801												
% Approach	0.0%	69.7%	30.2%	0.0%	0.0%	0.0%	0.0%	0.0%	0.0%	0.0%	0.0%	0.0%	0.0%	43.2%	56.6%	0.0%	0.0%	0.0%	0.0%	0.0%	0.0%	7.7%	26.9%	66.4%	0.0%	0.0%	0.0%	0.0%	0.0%												
% Total	0.0%	40.9%	17.7%	0.0%	58.6%	0.0%	0.0%	0.0%	0.0%	0.0%	0.0%	0.0%	0.0%	17.3%	22.7%	0.0%	0.0%	40.0%	0.0%	0.0%	0.0%	8.1%	0.4%	0.9%	0.0%	1.4%	0.0%	0.0%	0.0%												
Lights	1	1550	672	0	2203	0	0	0	0	0	0	0	0	655	844	0	0	1499	0	0	0	4	14	34	0	52	0	0	3754												
% Lights	100.0%	98.5%	99.9%	0.0%	99.9%	0.0%	0.0%	0.0%	0.0%	0.0%	0.0%	0.0%	0.0%	99.7%	97.9%	0.0%	0.0%	98.6%	0.0%	0.0%	0.0%	100.0%	100.0%	100.0%	0.0%	100.0%	0.0%	0.0%	98.0%												
Trucks	0	4	1	0	5	0	0	0	0	0	0	0	0	1	0	0	0	1	0	0	0	0	0	0	0	0	0	0	5												
% Trucks	0.0%	0.3%	0.1%	0.0%	0.2%	0.0%	0.0%	0.0%	0.0%	0.0%	0.0%	0.0%	0.0%	0.2%	0.0%	0.0%	0.0%	0.1%	0.0%	0.0%	0.0%	0.0%	0.0%	0.0%	0.0%	0.0%	0.0%	0.0%	0.2%												
Buses	0	17	0	0	17	0	0	0	0	0	0	0	0	1	18	0	0	19	0	0	0	0	0	0	0	0	0	0	36												
% Buses	0.0%	1.1%	0.0%	0.0%	0.0%	0.0%	0.0%	0.0%	0.0%	0.0%	0.0%	0.0%	0.0%	0.2%	2.1%	0.0%	0.0%	0.0%	0.0%	0.0%	0.0%	0.0%	0.0%	0.0%	0.0%	0.0%	0.0%	0.0%	0.9%												
Pedestrians	0	0	0	0	0	0	2	0	0	0	0	0	3	8	0	0	0	0	1	1	0	0	0	0	0	0	5	8	0												
% Pedestrians	0.0%	0.0%	0.0%	0.0%	0.0%	0.0%	100.0%	0.0%	0.0%	0.0%	0.0%	0.0%	100.0%	80.0%	0.0%	0.0%	0.0%	0.0%	100.0%	100.0%	0.0%	0.0%	0.0%	0.0%	0.0%	0.0%	83.3%	88.9%	0.0%												
Bicycles on Crosswalk	0	0	0	0	0	0	0	0	0	0	0	2	0	0	0	0	0	0	0	0	0	0	0	0	0	0	1	1	0												
% Bicycles on Crosswalk	0.0%	0.0%	0.0%	0.0%	0.0%	0.0%	0.0%	0.0%	0.0%	0.0%	0.0%	20.0%	0.0%	0.0%	0.0%	0.0%	0.0%	0.0%	0.0%	0.0%	0.0%	0.0%	0.0%	0.0%	0.0%	0.0%	18.7%	11.1%	0.0%												

Project : VBH Malta NY  
 Site : Site 4  
 Location : 42.948550, -73.790036  
 Survey Date : 2021-04-28, Wednesday

### Turning Movement Data Plot

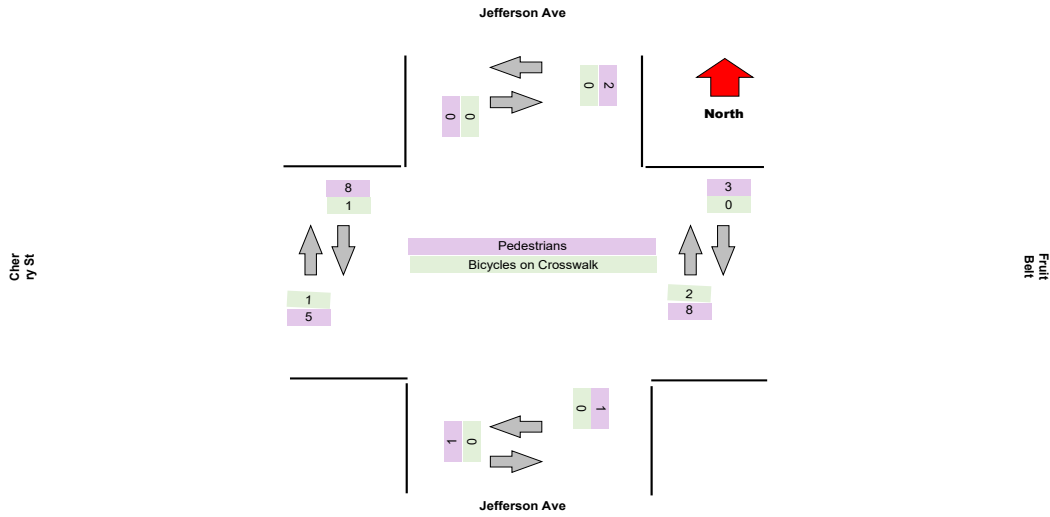
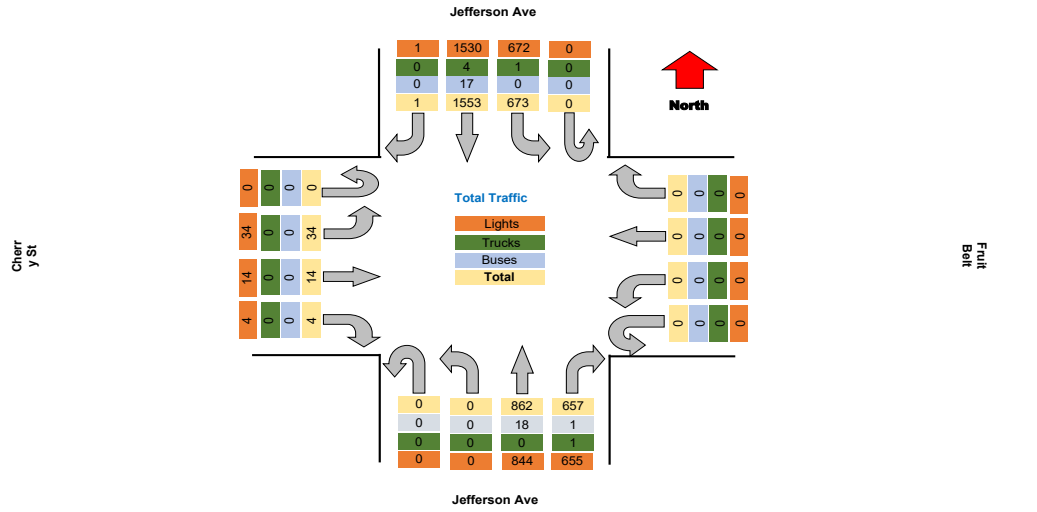

### Turning Movement Peak Hour Data (AM)

7:30:00 AM

Leg Direction	Jefferson Ave						Fruit Belt						Jefferson Ave						Cherry St						Total					
	Southbound			Northbound			Westbound			Eastbound			Northbound			Eastbound														
Start Time	Right	Thru	Left	U-Turn	App Total	Peds CW	Peds CCW	Right	Thru	Left	U-Turn	App Total	Peds CW	Peds CCW	Right	Thru	Left	U-Turn	App Total	Peds CW	Peds CCW	Right	Thru	Left	U-Turn	App Total	Peds CW	Peds CCW		
7:30:00 AM	0	56	25	0	81	0	0	0	0	0	0	0	0	0	37	57	0	0	94	0	0	0	1	3	0	4	1	1	179	
7:45:00 AM	0	73	16	0	89	0	0	0	0	0	0	0	0	0	34	42	0	0	76	0	0	0	0	1	1	0	2	0	167	
8:00:00 AM	0	81	20	0	101	0	0	0	0	0	0	0	0	0	31	57	0	0	88	0	0	0	0	1	3	0	4	0	193	
8:15:00 AM	0	86	16	0	102	0	0	0	0	0	0	0	1	1	21	41	0	0	64	0	0	0	0	1	3	0	4	0	178	
Grand Total	0	296	77	0	373	0	0	0	0	0	0	1	1	1	123	197	0	0	322	0	0	0	4	10	0	14	1	2	709	
% Approach	0.0%	79.4%	20.6%	0.0%	0.0%	0.0%	0.0%	#DIV/0!	#DIV/0!	#DIV/0!	#DIV/0!	0.0%	0.0%	0.0%	38.2%	61.2%	0.0%	0.0%	0.0%	0.0%	0.0%	0.0%	0.0%	26.6%	71.4%	0.0%	0.0%	0.0%	0.0%	
% Total	0.0%	41.7%	10.9%	0.0%	52.6%	0.0%	0.0%	0.0%	0.0%	0.0%	0.0%	0.0%	0.0%	0.0%	17.3%	27.8%	0.0%	0.0%	45.4%	0.0%	0.0%	0.0%	0.0%	0.6%	1.4%	0.0%	2.0%	0.0%	0.0%	
PHF	0.000	0.860	0.770	0.000	0.914	0.000	0.000	0.000	0.000	0.000	0.000	0.000	0.000	0.000	0.831	0.864	0.000	0.000	0.856	0.000	0.000	0.000	0.000	1.000	0.833	0.000	0.875	0.000	0.000	0.918
Lights	0	290	77	0	367	0	0	0	0	0	0	0	0	0	123	194	0	0	317	0	0	0	4	10	0	14	0	0	698	
% Lights	0.0%	98.0%	100.0%	0.0%	98.4%	0.0%	0.0%	0.0%	0.0%	0.0%	0.0%	0.0%	0.0%	0.0%	100.0%	98.5%	0.0%	0.0%	98.4%	0.0%	0.0%	0.0%	100.0%	100.0%	0.0%	100.0%	0.0%	0.0%	98.4%	
Trucks	0	0	0	0	0	0	0	0	0	0	0	0	0	0	0	0	0	0	0	0	0	0	0	0	0	0	0	0	0	
% Trucks	0.0%	0.0%	0.0%	0.0%	0.0%	0.0%	0.0%	0.0%	0.0%	0.0%	0.0%	0.0%	0.0%	0.0%	0.0%	0.0%	0.0%	0.0%	0.0%	0.0%	0.0%	0.0%	0.0%	0.0%	0.0%	0.0%	0.0%	0.0%	0.0%	
Buses	0	6	0	0	6	0	0	0	0	0	0	0	0	0	3	0	0	0	3	0	0	0	0	0	0	0	0	0	9	
% Buses	0.0%	2.0%	0.0%	0.0%	0.0%	0.0%	0.0%	0.0%	0.0%	0.0%	0.0%	0.0%	0.0%	0.0%	0.0%	1.5%	0.0%	0.0%	0.0%	0.0%	0.0%	0.0%	0.0%	0.0%	0.0%	0.0%	0.0%	0.0%	1.3%	
Pedestrians	0	0	0	0	0	0	0	0	0	0	1	1	0	0	0	0	0	0	0	0	0	0	0	0	0	0	1	2	0	
% Pedestrians	0.0%	0.0%	0.0%	0.0%	0.0%	0.0%	0.0%	0.0%	0.0%	0.0%	100.0%	100.0%	0.0%	0.0%	0.0%	0.0%	0.0%	0.0%	0.0%	0.0%	0.0%	0.0%	0.0%	0.0%	0.0%	0.0%	100.0%	100.0%	0.0%	
Bicycles on Crosswalk	0	0	0	0	0	0	0	0	0	0	0	0	0	0	0	0	0	0	0	0	0	0	0	0	0	0	0	0	0	
% Bicycles on Crosswalk	0.0%	0.0%	0.0%	0.0%	0.0%	0.0%	0.0%	0.0%	0.0%	0.0%	0.0%	0.0%	0.0%	0.0%	0.0%	0.0%	0.0%	0.0%	0.0%	0.0%	0.0%	0.0%	0.0%	0.0%	0.0%	0.0%	0.0%	0.0%	0.0%	

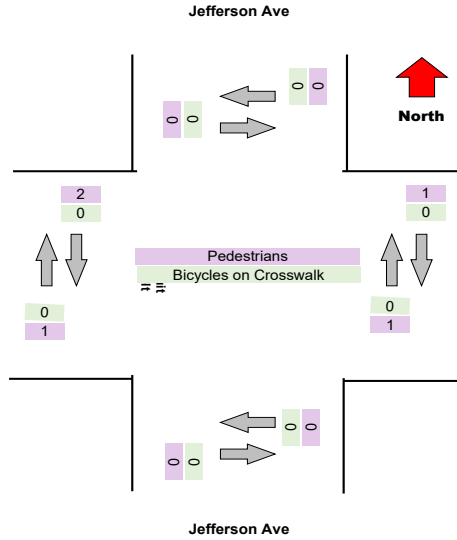
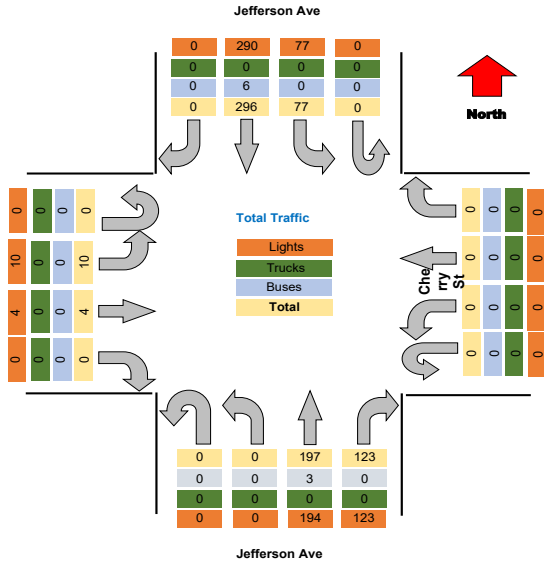



Project : VBH Malta NY  
Site : Site 4  
Location : 42.948550, -73.790036

TSTData.com

Survey Date : 2021-04-28, Wednesday

### Turning Movement Peak Hour Data (PM)

4:15:00 PM

Leg Direction	Jefferson Ave						Fruit Belt						Jefferson Ave						Cherry St						Total				
	Southbound			Northbound			Westbound			Eastbound			Northbound			Eastbound													
Start Time	Right	Thru	Left	U-Turn	App Total	Peds CW	Peds CCW	Right	Thru	Left	U-Turn	App Total	Peds CW	Peds CCW	Right	Thru	Left	U-Turn	App Total	Peds CW	Peds CCW	Right	Thru	Left	U-Turn	App Total	Peds CW	Peds CCW	
4:15:00 PM	0	134	72	0	206	0	1	0	0	0	0	0	1	1	65	53	0	0	118	1	0	1	1	0	0	2	1	1	326
4:30:00 PM	1	147	80	0	228	0	0	0	0	0	0	0	2	2	62	53	0	0	115	0	0	0	0	5	0	5	0	0	348
4:45:00 PM	0	137	69	0	206	0	1	0	0	0	0	0	2	2	44	70	0	0	114	0	0	0	0	4	0	4	2	1	324
5:00:00 PM	0	117	83	0	200	0	0	0	0	0	0	0	0	0	64	81	0	0	145	0	0	0	0	2	0	2	0	0	347
<b>Grand Total</b>	<b>1</b>	<b>535</b>	<b>304</b>	<b>0</b>	<b>840</b>	<b>0</b>	<b>2</b>	<b>0</b>	<b>0</b>	<b>0</b>	<b>0</b>	<b>3</b>	<b>5</b>	<b>5</b>	<b>235</b>	<b>257</b>	<b>0</b>	<b>0</b>	<b>492</b>	<b>1</b>	<b>0</b>	<b>1</b>	<b>1</b>	<b>11</b>	<b>0</b>	<b>13</b>	<b>3</b>	<b>2</b>	<b>1345</b>
% Approach	0.1%	63.7%	36.2%	0.0%	0.0%	0.0%	0.0%	#DIV/0!	#DIV/0!	#DIV/0!	#DIV/0!	0.0%	0.0%	0.0%	47.6%	52.2%	0.0%	0.0%	0.0%	0.0%	0.0%	0.0%	7.7%	7.7%	84.6%	0.0%	0.0%	0.0%	0.0%
% Total	0.1%	39.8%	22.6%	0.0%	62.5%	0.0%	0.0%	0.0%	0.0%	0.0%	0.0%	0.0%	0.0%	0.0%	17.5%	19.1%	0.0%	0.0%	36.6%	0.0%	0.0%	0.1%	0.1%	0.8%	0.0%	1.0%	0.0%	0.0%	
PHF	0.250	0.910	0.916	0.000	0.921	0.000	0.000	0.000	0.000	0.000	0.000	0.000	0.000	0.000	0.904	0.793	0.000	0.000	0.848	0.000	0.000	0.250	0.250	0.550	0.000	0.650	0.000	0.000	0.966
Lights	1	528	304	0	833	0	0	0	0	0	0	0	0	0	235	252	0	0	487	0	0	1	1	11	0	13	0	0	1333
% Lights	100.0%	98.7%	100.0%	0.0%	99.2%	0.0%	0.0%	0.0%	0.0%	0.0%	0.0%	0.0%	0.0%	0.0%	100.0%	98.1%	0.0%	0.0%	99.0%	0.0%	0.0%	100.0%	100.0%	100.0%	0.0%	100.0%	0.0%	0.0%	99.1%
Trucks	0	1	0	0	1	0	0	0	0	0	0	0	0	0	0	0	0	0	0	0	0	0	0	0	0	0	0	0	1
% Trucks	0.0%	0.2%	0.0%	0.0%	0.1%	0.0%	0.0%	0.0%	0.0%	0.0%	0.0%	0.0%	0.0%	0.0%	0.0%	0.0%	0.0%	0.0%	0.0%	0.0%	0.0%	0.0%	0.0%	0.0%	0.0%	0.0%	0.0%	0.0%	0.1%
Buses	0	4	0	0	4	0	0	0	0	0	0	0	0	0	5	0	0	0	5	0	0	0	0	0	0	0	0	0	9
% Buses	0.0%	0.7%	0.0%	0.0%	0.0%	0.0%	0.0%	0.0%	0.0%	0.0%	0.0%	0.0%	0.0%	0.0%	0.0%	1.9%	0.0%	0.0%	0.0%	0.0%	0.0%	0.0%	0.0%	0.0%	0.0%	0.0%	0.0%	0.0%	0.7%
Pedestrians	0	0	0	0	0	2	0	0	0	0	1	5	0	0	0	0	0	0	1	0	0	0	0	0	0	0	2	1	0
% Pedestrians	0.0%	0.0%	0.0%	0.0%	0.0%	0.2%	100.0%	0.0%	0.0%	0.0%	0.0%	100.0%	0.0%	0.0%	0.0%	0.0%	0.0%	0.0%	0.0%	0.0%	100.0%	0.0%	0.0%	0.0%	0.0%	0.0%	0.0%	50.0%	0.0%
Bicycles on Crosswalk	0	0	0	0	0	0	0	0	0	0	0	0	0	0	0	0	0	0	0	0	0	0	0	0	0	0	1	1	0
% Bicycles on Crosswalk	0.0%	0.0%	0.0%	0.0%	0.0%	0.0%	0.0%	0.0%	0.0%	0.0%	0.0%	0.0%	0.0%	0.0%	0.0%	0.0%	0.0%	0.0%	0.0%	0.0%	0.0%	0.0%	0.0%	0.0%	0.0%	0.0%	33.3%	50.0%	0.0%

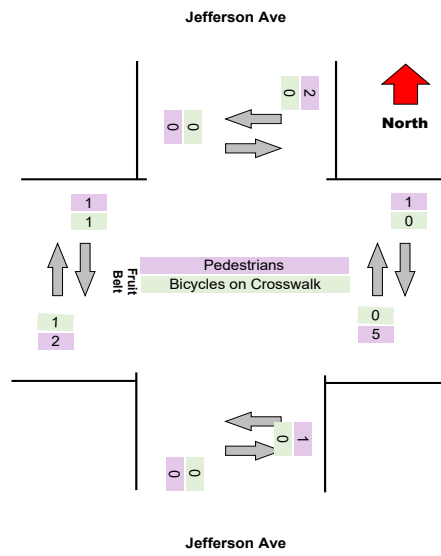
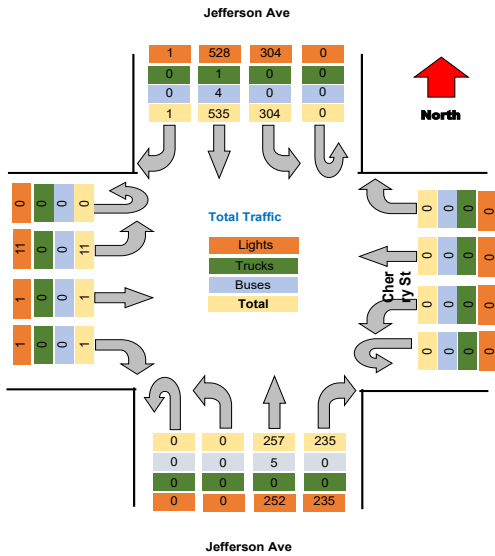

Project : VBH Malta NY  
 Site : Site 4  
 Location : 42.948550, -73.790036

TSTData.com

Survey Date : 2021-04-28, Wednesday

Project	LaBella
Project Code	LaBella
Site Name	10
Legs and Movements	All Processed Legs & Move
Bin Size	15 minutes
Survey Date	2021-11-03, Wednesday
Location	10
Latitude and Longitude	42.896936, -78.853849

	Start	End	PHF
Forced Peak AM	2021/11/03 07:30:00	2021/11/03 08:30:00	0.93
Forced Peak PM	2021/11/03 16:30:00	2021/11/03 17:30:00	0.96
AM Peak	2021/11/03 07:30:00	2021/11/03 08:30:00	0.93
PM Peak	2021/11/03 16:15:00	2021/11/03 17:15:00	0.92

### Turning Movement Data

Leg Direction	Jefferson Ave												Fruit Belt												Jefferson Ave												Cherry St												Total
	Southbound						Westbound						Northbound						Eastbound																														
	Right	Thru	Left	U-Turn	App Total	Peds CW	Peds CCW	Right	Thru	Left	U-Turn	App Total	Peds CW	Peds CCW	Right	Thru	Left	U-Turn	App Total	Peds CW	Peds CCW	Right	Thru	Left	U-Turn	App Total	Peds CW	Peds CCW																					
6:30:00 AM	0	38	16	0	54	0	0	0	0	0	0	0	0	0	12	37	0	0	49	0	0	0	1	5	0	6	0	1	109																				
6:45:00 AM	0	58	20	0	78	0	0	0	0	0	0	0	0	0	23	47	0	0	70	0	0	0	1	1	0	2	0	1	150																				
Hourly Total	0	96	36	0	132	0	0	0	0	0	0	0	0	0	35	84	0	0	119	0	0	0	2	6	0	8	0	2	259																				
7:00:00 AM	0	56	28	0	84	0	0	0	0	0	0	0	0	0	23	50	0	0	73	0	0	0	3	3	0	6	0	2	163																				
7:15:00 AM	0	72	17	0	89	0	0	0	0	0	0	0	0	0	37	57	0	0	94	0	1	0	0	2	0	2	1	0	185																				
7:30:00 AM	0	96	31	0	127	0	0	0	0	0	0	0	0	0	52	77	0	0	129	0	0	0	1	3	0	4	0	2	260																				
7:45:00 AM	0	110	35	0	145	0	0	0	0	0	0	0	1	1	47	96	0	0	144	0	0	0	0	2	0	2	0	0	291																				
Hourly Total	0	334	111	0	445	0	0	0	0	0	0	0	1	1	159	280	0	0	440	0	1	0	4	10	0	14	1	4	899																				
8:00:00 AM	0	142	36	0	178	0	0	0	0	0	0	0	0	0	38	71	0	0	109	0	0	0	3	3	0	6	0	0	293																				
8:15:00 AM	0	120	21	0	141	0	0	0	0	0	0	0	0	0	45	55	0	0	100	0	0	0	2	3	0	5	0	0	246																				
Hourly Total	0	262	57	0	319	0	0	0	0	0	0	0	0	0	83	126	0	0	209	0	0	0	5	6	0	11	0	0	539																				
4:00:00 PM	0	157	74	0	231	0	0	0	0	0	0	0	0	0	78	83	0	0	161	0	0	0	2	4	0	6	1	4	398																				
4:15:00 PM	0	166	79	0	245	0	0	0	0	0	0	0	1	1	80	72	0	0	152	0	0	0	4	6	0	10	3	1	407																				
4:30:00 PM	0	153	76	0	229	0	0	0	0	0	0	0	0	0	67	78	0	0	145	0	0	0	2	2	0	4	0	0	378																				
4:45:00 PM	0	153	63	0	216	0	0	0	0	0	0	1	0	57	77	0	0	134	0	0	1	2	0	0	3	0	0	353																					
Hourly Total	0	629	292	0	921	0	0	0	0	0	0	1	1	262	310	0	0	592	0	0	1	10	12	0	23	4	5	1536																					
5:00:00 PM	0	134	65	0	199	0	0	0	0	0	0	1	0	72	84	0	0	156	0	0	0	0	3	0	3	0	0	358																					
5:15:00 PM	0	158	73	0	231	0	0	0	0	0	0	1	0	47	72	0	0	119	0	0	0	1	4	0	5	2	1	355																					
5:30:00 PM	0	121	42	0	163	0	0	0	0	0	0	1	0	69	68	0	0	137	1	0	0	1	4	0	5	1	1	305																					
5:45:00 PM	1	120	44	0	165	0	0	0	0	0	0	1	1	51	52	0	0	103	0	0	1	1	5	0	7	0	0	275																					
Hourly Total	1	533	224	0	758	0	0	0	0	0	0	4	1	239	276	0	0	515	1	0	1	3	16	0	20	3	2	1293																					
Grand Total	1	1854	720	0	2575	0	0	0	0	0	0	5	3	798	1076	0	0	1875	1	1	2	24	50	0	76	8	13	4526																					
% Approach	0.0%	72.0%	28.0%	0.0%	0.0%	0.0%	0.0%	0.0%	0.0%	0.0%	0.0%	0.0%	0.0%	42.6%	57.4%	0.0%	0.0%	0.0%	0.0%	2.6%	31.6%	65.8%	0.0%	0.0%	0.0%	0.0%	0.0%																						
% Total	0.0%	41.0%	15.9%	0.0%	56.9%	0.0%	0.0%	0.0%	0.0%	0.0%	0.0%	0.0%	0.0%	17.6%	23.8%	0.0%	0.0%	41.4%	0.0%	0.0%	0.0%	0.5%	1.1%	0.0%	1.7%	0.0%	0.0%	0.0%																					
Lights	1	1779	720	0	2500	0	0	0	0	0	0	0	0	786	1024	0	0	1810	0	0	2	24	48	0	74	0	0	4384																					
% Lights	100.0%	96.0%	100.0%	0.0%	97.1%	0.0%	0.0%	0.0%	0.0%	0.0%	0.0%	0.0%	0.0%	88.5%	95.2%	0.0%	0.0%	96.5%	0.0%	0.0%	100.0%	100.0%	96.0%	0.0%	97.4%	0.0%	0.0%	96.9%																					
Trucks	0	3	0	0	3	0	0	0	0	0	0	0	0	2	1	0	0	3	0	0	0	0	0	0	0	0	0	6																					
% Trucks	0.0%	0.2%	0.0%	0.0%	0.1%	0.0%	0.0%	0.0%	0.0%	0.0%	0.0%	0.0%	0.0%	0.3%	0.1%	0.0%	0.0%	0.2%	0.0%	0.0%	0.0%	0.0%	0.0%	0.0%	0.0%	0.0%	0.0%	0.1%																					
Buses	0	72	0	0	72	0	0	0	0	0	0	0	0	10	51	0	0	61	0	0	0	0	2	0	2	0	0	135																					
% Buses	0.0%	3.9%	0.0%	0.0%	0.0%	0.0%	0.0%	0.0%	0.0%	0.0%	0.0%	0.0%	0.0%	1.3%	4.7%	0.0%	0.0%	0.0%	0.0%	0.0%	0.0%	4.0%	0.0%	0.0%	0.0%	0.0%	3.0%																						
Pedestrians	0	0	0	0	0	0	0	0	0	0	0	4	3	0	0	0	0	0	1	1	0	0	0	0	0	6	12	0																					
% Pedestrians	0.0%	0.0%	0.0%	0.0%	0.0%	0.0%	0.0%	0.0%	0.0%	0.0%	0.0%	80.0%	100.0%	0.0%	0.0%	0.0%	0.0%	0.0%	100.0%	100.0%	0.0%	0.0%	0.0%	0.0%	0.0%	75.0%	92.3%	0.0%																					
Bicycles on Crosswalk	0	0	0	0	0	0	0	0	0	0	0	1	0	0	0	0	0	0	0	0	0	0	0	0	0	2	1	0																					
% Bicycles on Crosswalk	0.0%	0.0%	0.0%	0.0%	0.0%	0.0%	0.0%	0.0%	0.0%	0.0%	0.0%	20.0%	0.0%	0.0%	0.0%	0.0%	0.0%	0.0%	0.0%	0.0%	0.0%	0.0%	0.0%	0.0%	0.0%	25.0%	7.7%	0.0%																					

Project : VBH Malta NY  
 Site : Site 4  
 Location : 42.948550, -73.790036  
 Survey Date : 2021-04-28, Wednesday

### Turning Movement Data Plot

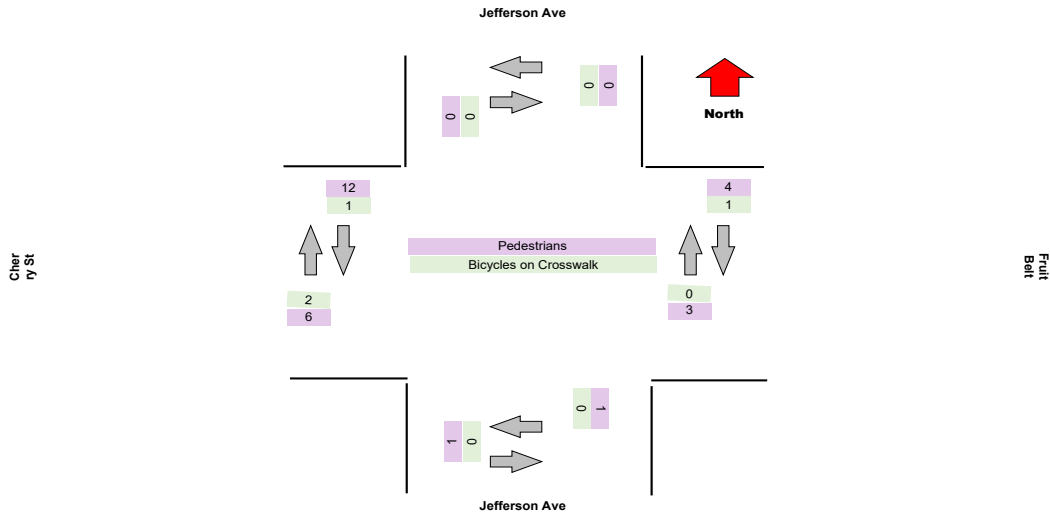
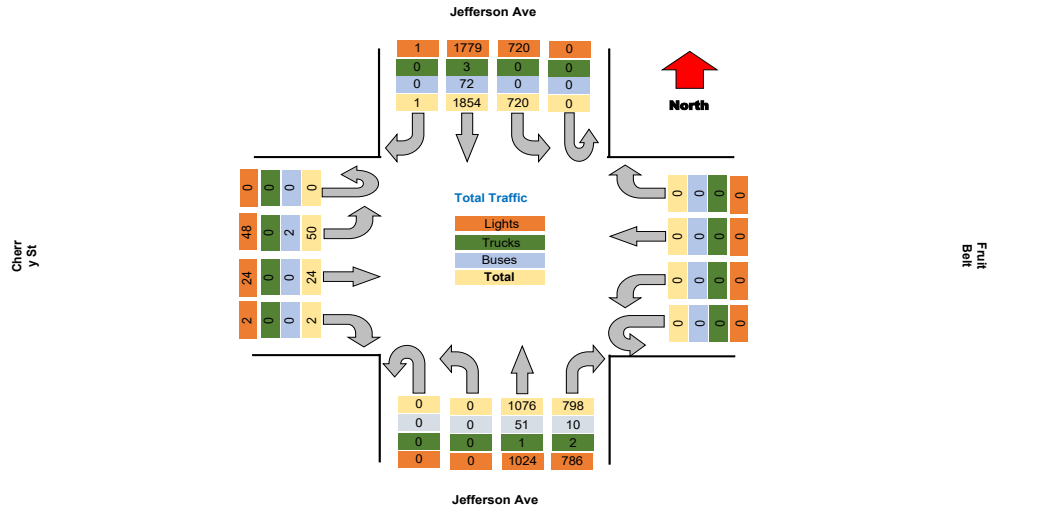

### Turning Movement Peak Hour Data (AM)

7:30:00 AM

Leg Direction	Jefferson Ave										Fruit Belt										Jefferson Ave										Cherry St										Total
	Southbound					Westbound					Northbound					Eastbound																									
	Right	Thru	Left	U-Turn	App Total	Right	Thru	Left	U-Turn	App Total	Right	Thru	Left	U-Turn	App Total	Right	Thru	Left	U-Turn	App Total																					
7:30:00 AM	0	96	31	0	127	0	0	0	0	0	52	77	0	0	129	0	1	3	0	4	0	0	0	0	0	260															
7:45:00 AM	0	110	35	0	145	0	0	0	0	0	47	96	0	0	144	0	0	2	0	2	0	0	0	0	0	291															
8:00:00 AM	0	142	36	0	178	0	0	0	0	0	38	71	0	0	109	0	0	3	0	3	0	0	0	0	0	293															
8:15:00 AM	0	120	21	0	141	0	0	0	0	0	45	55	0	0	100	0	0	2	3	5	0	0	0	0	0	246															
Grand Total	0	468	123	0	591	0	0	0	0	0	182	299	0	0	482	0	0	6	11	17	0	0	0	0	0	1099															
% Approach	0.0%	79.2%	20.8%	0.0%	0.0%	0.0%	0.0%	0.0%	0.0%	0.0%	37.8%	82.0%	0.0%	0.0%	0.0%	0.0%	35.3%	64.7%	0.0%	0.0%	0.0%	0.0%	0.0%	0.0%	0.0%	0.0%															
% Total	0.0%	42.9%	11.3%	0.0%	54.2%	0.0%	0.0%	0.0%	0.0%	0.0%	16.7%	27.4%	0.0%	0.0%	44.2%	0.0%	0.6%	1.0%	0.0%	1.6%	0.0%	0.0%	0.0%	0.0%	0.0%	0.0%															
PHF	0.000	0.824	0.854	0.000	0.830	0.000	0.000	0.000	0.000	0.000	0.875	0.779	0.000	0.000	0.837	0.000	0.500	0.917	0.000	0.708	0.000	0.000	0.000	0.000	0.000	0.930															
Lights	0	433	123	0	556	0	0	0	0	0	175	277	0	0	452	0	0	6	10	16	0	0	0	0	0	1024															
% Lights	0.0%	92.5%	100.0%	0.0%	94.1%	0.0%	0.0%	0.0%	0.0%	0.0%	86.2%	92.6%	0.0%	0.0%	93.8%	0.0%	0.0%	100.0%	90.9%	94.1%	0.0%	0.0%	0.0%	0.0%	0.0%	93.9%															
Trucks	0	2	0	0	2	0	0	0	0	0	2	0	0	0	2	0	0	0	0	0	0	0	0	0	0	4															
% Trucks	0.0%	0.4%	0.0%	0.0%	0.3%	0.0%	0.0%	0.0%	0.0%	0.0%	1.1%	0.0%	0.0%	0.0%	0.4%	0.0%	0.0%	0.0%	0.0%	0.0%	0.0%	0.0%	0.0%	0.0%	0.0%	0.4%															
Buses	0	33	0	0	33	0	0	0	0	0	5	22	0	0	27	0	0	1	0	1	0	0	0	0	0	61															
% Buses	0.0%	7.1%	0.0%	0.0%	0.0%	0.0%	0.0%	0.0%	0.0%	0.0%	2.7%	7.4%	0.0%	0.0%	0.0%	0.0%	0.0%	9.1%	0.0%	0.0%	0.0%	0.0%	0.0%	0.0%	0.0%	5.6%															
Pedestrians	0	0	0	0	0	0	0	0	0	0	0	0	0	0	0	0	0	0	0	0	0	0	0	0	2	0															
% Pedestrians	0.0%	0.0%	0.0%	0.0%	0.0%	0.0%	0.0%	0.0%	0.0%	0.0%	0.0%	0.0%	0.0%	0.0%	0.0%	0.0%	0.0%	0.0%	0.0%	0.0%	0.0%	0.0%	100.0%	0.0%	100.0%	0.0%															
Bicycles on Crosswalk	0	0	0	0	0	0	0	0	0	0	0	0	0	0	0	0	0	0	0	0	0	0	0	0	0	0															
% Bicycles on Crosswalk	0.0%	0.0%	0.0%	0.0%	0.0%	0.0%	0.0%	0.0%	0.0%	0.0%	0.0%	0.0%	0.0%	0.0%	0.0%	0.0%	0.0%	0.0%	0.0%	0.0%	0.0%	0.0%	0.0%	0.0%	0.0%	0.0%															

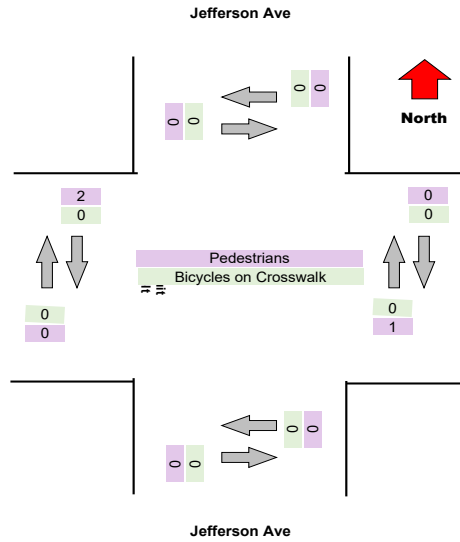
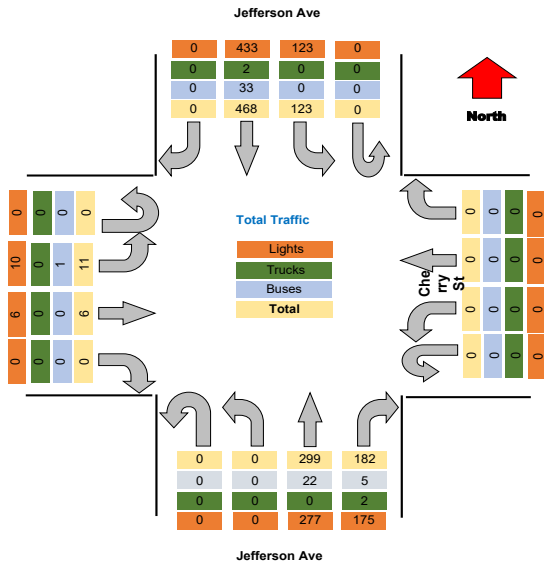

### Turning Movement Peak Hour Data (PM)

4:15:00 PM

Leg Direction	Jefferson Ave						Fruit Belt						Jefferson Ave						Cherry St						Total					
	Southbound			Northbound			Westbound			Eastbound			Northbound			Eastbound														
Start Time	Right	Thru	Left	U-Turn	App Total	Peds CW	Peds CCW	Right	Thru	Left	U-Turn	App Total	Peds CW	Peds CCW	Right	Thru	Left	U-Turn	App Total	Peds CW	Peds CCW	Right	Thru	Left	U-Turn	App Total	Peds CW	Peds CCW		
4:15:00 PM	0	166	79	0	245	0	0	0	0	0	0	0	0	1	80	72	0	0	152	0	0	0	4	6	0	10	3	1	407	
4:30:00 PM	0	153	76	0	229	0	0	0	0	0	0	0	0	0	67	78	0	0	145	0	0	0	2	2	0	4	0	0	378	
4:45:00 PM	0	153	63	0	216	0	0	0	0	0	0	0	1	0	57	77	0	0	134	0	0	1	2	0	3	0	0	353		
5:00:00 PM	0	134	45	0	199	0	0	0	0	0	0	0	1	0	72	84	0	0	156	0	0	0	0	3	0	3	0	358		
Grand Total	0	636	263	0	899	0	0	0	0	0	0	2	1	0	276	311	0	0	587	0	0	1	8	11	0	20	3	1	1488	
% Approach	0.0%	68.2%	31.8%	0.0%	0.0%	0.0%	0.0%	#DIV/0!	#DIV/0!	#DIV/0!	#DIV/0!	0.0%	0.0%	0.0%	47.0%	53.0%	0.0%	0.0%	0.0%	0.0%	0.0%	0.0%	5.0%	40.0%	55.0%	0.0%	0.0%	0.0%	0.0%	
% Total	0.0%	40.5%	18.9%	0.0%	59.4%	0.0%	0.0%	0.0%	0.0%	0.0%	0.0%	0.0%	0.0%	0.0%	18.4%	20.8%	0.0%	0.0%	39.2%	0.0%	0.0%	0.1%	0.5%	0.7%	0.0%	1.3%	0.0%	0.0%	0.0%	
PHF	0.000	0.913	0.896	0.000	0.907	0.000	0.000	0.000	0.000	0.000	0.000	0.000	0.000	0.000	0.863	0.926	0.000	0.000	0.841	0.000	0.000	0.250	0.500	0.458	0.000	0.500	0.000	0.000	0.919	
Lights	0	589	283	0	872	0	0	0	0	0	0	0	0	0	273	301	0	0	574	0	0	1	8	11	0	20	0	0	1466	
% Lights	0.0%	97.2%	100.0%	0.0%	98.1%	0.0%	0.0%	0.0%	0.0%	0.0%	0.0%	0.0%	0.0%	0.0%	98.9%	96.8%	0.0%	0.0%	97.8%	0.0%	0.0%	100.0%	100.0%	100.0%	0.0%	100.0%	0.0%	0.0%	98.0%	
Trucks	0	0	0	0	0	0	0	0	0	0	0	0	0	0	0	0	0	0	0	0	0	0	0	0	0	0	0	0	0	
% Trucks	0.0%	0.0%	0.0%	0.0%	0.0%	0.0%	0.0%	0.0%	0.0%	0.0%	0.0%	0.0%	0.0%	0.0%	0.0%	0.0%	0.0%	0.0%	0.0%	0.0%	0.0%	0.0%	0.0%	0.0%	0.0%	0.0%	0.0%	0.0%	0.0%	
Buses	0	17	0	0	17	0	0	0	0	0	0	0	0	0	3	10	0	0	13	0	0	0	0	0	0	0	0	0	30	
% Buses	0.0%	2.8%	0.0%	0.0%	0.0%	0.0%	0.0%	0.0%	0.0%	0.0%	0.0%	0.0%	0.0%	0.0%	1.1%	3.2%	0.0%	0.0%	0.0%	0.0%	0.0%	0.0%	0.0%	0.0%	0.0%	0.0%	0.0%	0.0%	2.0%	
Pedestrians	0	0	0	0	0	0	0	0	0	0	0	2	1	0	0	0	0	0	0	0	0	0	0	0	0	0	1	1	0	
% Pedestrians	0.0%	0.0%	0.0%	0.0%	0.0%	0.0%	0.0%	0.0%	0.0%	0.0%	0.0%	100.0%	100.0%	0.0%	0.0%	0.0%	0.0%	0.0%	0.0%	0.0%	0.0%	0.0%	0.0%	0.0%	0.0%	0.0%	0.0%	33.3%	100.0%	0.0%
Bicycles on Crosswalk	0	0	0	0	0	0	0	0	0	0	0	0	0	0	0	0	0	0	0	0	0	0	0	0	0	0	2	0	0	
% Bicycles on Crosswalk	0.0%	0.0%	0.0%	0.0%	0.0%	0.0%	0.0%	0.0%	0.0%	0.0%	0.0%	0.0%	0.0%	0.0%	0.0%	0.0%	0.0%	0.0%	0.0%	0.0%	0.0%	0.0%	0.0%	0.0%	0.0%	0.0%	66.7%	0.0%	0.0%	

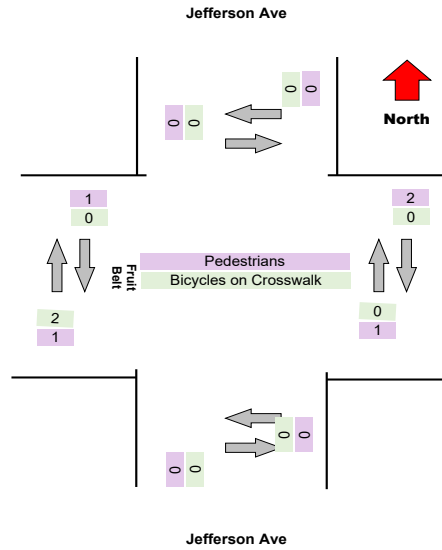
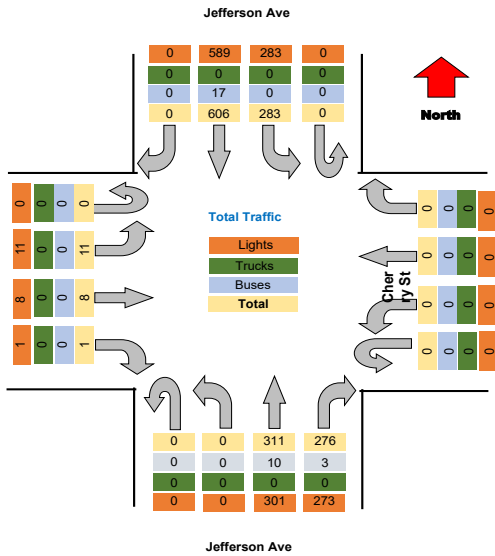

Project : VBH Malta NY  
Site : Site 4  
Location : 42.948550, -73.790036

TSTData.com

Survey Date : 2021-04-28, Wednesday

Project	LaBella
Project Code	LaBella
Site Name	10
Legs and Movements	All Processed Legs & Move
Bin Size	15 minutes
Survey Date	2021-11-04, Thursday
Location	10
Latitude and Longitude	42.896936, -78.853849

	Start	End	PHF
Forced Peak AM	2021/11/04 07:30:00	2021/11/04 08:30:00	0.92
Forced Peak PM	2021/11/04 16:30:00	2021/11/04 17:30:00	0.96
AM Peak	2021/11/04 07:30:00	2021/11/04 08:30:00	0.92
PM Peak	2021/11/04 16:15:00	2021/11/04 17:15:00	0.94

### Turning Movement Data

Leg Direction	Jefferson Ave						Fruit Belt						Jefferson Ave						Cherry St						Total								
	Southbound			Northbound			Westbound			Eastbound			Northbound			Eastbound																	
	Right	Thru	Left	U-Turn	App Total	Peds CV	Peds CCV	Right	Thru	Left	U-Turn	App Total	Peds CV	Peds CCV	Right	Thru	Left	U-Turn	App Total	Peds CV	Peds CCV												
6:30:00 AM	0	46	11	0	<b>57</b>	0	0	0	0	0	0	0	0	0	27	31	0	0	<b>58</b>	0	0	0	0	0	0	0	0	<b>116</b>					
6:45:00 AM	0	58	11	0	<b>69</b>	0	0	0	0	0	0	0	0	0	20	50	0	0	<b>70</b>	0	0	0	0	0	0	0	0	<b>142</b>					
Hourly Total	0	104	22	0	<b>126</b>	0	0	0	0	0	0	0	0	0	47	81	0	0	<b>128</b>	0	0	0	0	0	0	0	0	<b>257</b>					
7:00:00 AM	0	50	25	0	<b>75</b>	0	0	0	0	0	0	0	0	0	29	40	0	0	<b>69</b>	0	0	0	0	0	0	0	0	<b>147</b>					
7:15:00 AM	0	65	16	0	<b>81</b>	0	0	0	0	0	0	0	0	0	30	56	0	0	<b>86</b>	0	0	0	0	0	0	0	0	<b>169</b>					
7:30:00 AM	0	94	30	0	<b>124</b>	0	0	0	0	0	0	0	0	0	37	76	0	0	<b>113</b>	0	0	0	0	0	0	3	2	<b>242</b>					
7:45:00 AM	0	109	34	0	<b>143</b>	0	0	0	0	0	0	0	0	0	40	102	0	0	<b>142</b>	0	0	0	0	0	0	4	0	<b>289</b>					
Hourly Total	0	318	105	0	<b>423</b>	0	0	0	0	0	0	0	0	0	138	274	0	0	<b>410</b>	0	0	0	0	0	0	4	10	<b>847</b>					
8:00:00 AM	0	104	32	0	<b>136</b>	0	0	0	0	0	0	0	1	0	41	89	0	0	<b>131</b>	0	0	0	0	0	0	1	5	<b>273</b>					
8:15:00 AM	0	125	28	0	<b>153</b>	0	0	0	0	0	0	1	0	0	35	63	0	0	<b>99</b>	0	0	0	0	0	0	2	1	<b>254</b>					
Hourly Total	0	229	60	0	<b>289</b>	0	0	0	0	0	0	2	0	0	76	152	0	0	<b>230</b>	0	0	0	0	0	0	1	7	<b>527</b>					
4:00:00 PM	0	185	96	0	<b>281</b>	0	0	0	0	0	0	0	0	0	58	48	0	0	<b>106</b>	0	0	0	0	0	0	1	2	<b>393</b>					
4:15:00 PM	0	169	72	0	<b>241</b>	2	0	0	0	0	0	0	2	0	62	80	0	0	<b>142</b>	0	0	0	0	0	0	1	3	<b>387</b>					
4:30:00 PM	0	129	70	0	<b>199</b>	0	0	0	0	0	0	2	0	0	81	76	0	0	<b>157</b>	0	0	0	0	0	0	1	5	<b>362</b>					
4:45:00 PM	0	146	65	0	<b>211</b>	0	0	0	0	0	0	0	0	0	65	68	0	0	<b>133</b>	0	0	0	0	0	0	2	2	<b>348</b>					
Hourly Total	0	629	303	0	<b>932</b>	2	0	0	0	0	0	2	2	0	268	272	0	0	<b>538</b>	0	0	0	0	0	0	1	6	<b>1490</b>					
5:00:00 PM	0	135	76	0	<b>211</b>	0	0	0	0	0	0	1	0	0	70	73	0	0	<b>143</b>	0	0	0	0	0	0	0	3	<b>357</b>					
5:15:00 PM	0	134	58	0	<b>192</b>	0	0	0	0	0	0	0	1	0	46	77	0	0	<b>123</b>	0	0	0	0	0	0	0	3	<b>322</b>					
5:30:00 PM	0	116	50	0	<b>166</b>	0	0	0	0	0	0	0	1	0	56	73	0	0	<b>129</b>	0	0	0	0	0	0	2	2	<b>302</b>					
5:45:00 PM	0	134	36	0	<b>170</b>	0	0	0	0	0	0	1	0	0	46	70	0	0	<b>116</b>	0	0	0	0	0	0	2	2	<b>290</b>					
Hourly Total	0	519	220	0	<b>739</b>	0	0	0	0	0	0	1	3	0	218	293	0	0	<b>511</b>	0	0	0	0	0	0	2	7	<b>1274</b>					
Grand Total	0	1799	710	0	<b>2509</b>	2	0	0	0	0	0	5	5	0	743	1072	0	0	<b>1817</b>	0	0	0	0	0	0	3	19	<b>4392</b>					
% Approach	0.0%	71.7%	28.3%	0.0%	<b>0.0%</b>	0.0%	0.0%	0.0%	0.0%	<b>0.0%</b>	0.0%	0.0%	0.0%	0.0%	40.9%	59.0%	0.0%	0.0%	<b>0.0%</b>	0.0%	0.0%	0.0%	0.0%	0.0%	0.0%	4.5%	28.8%	66.7%	0.0%	<b>0.0%</b>	0.0%	0.0%	<b>0.0%</b>
% Total	0.0%	41.0%	16.2%	0.0%	<b>57.1%</b>	0.0%	0.0%	0.0%	0.0%	<b>0.0%</b>	0.0%	0.0%	0.0%	0.0%	16.9%	24.4%	0.0%	0.0%	<b>41.4%</b>	0.0%	0.0%	0.0%	0.0%	0.0%	0.0%	0.1%	0.4%	1.0%	0.0%	<b>1.5%</b>	0.0%	0.0%	<b>0.0%</b>
Lights	0	1728	708	0	<b>2436</b>	0	0	0	0	0	0	0	0	0	733	1020	0	0	<b>1753</b>	0	0	0	0	0	0	2	19	<b>4252</b>					
% Lights	0.0%	96.1%	99.7%	0.0%	<b>97.1%</b>	0.0%	0.0%	0.0%	0.0%	<b>0.0%</b>	0.0%	0.0%	0.0%	0.0%	88.7%	95.1%	0.0%	0.0%	<b>96.8%</b>	0.0%	0.0%	0.0%	0.0%	0.0%	0.0%	66.7%	100.0%	95.5%	0.0%	<b>95.5%</b>	0.0%	0.0%	<b>96.8%</b>
Trucks	0	0	0	0	<b>0</b>	0	0	0	0	0	0	0	0	0	1	4	0	0	<b>5</b>	0	0	0	0	0	0	0	0	<b>0</b>	0	0	0	<b>0</b>	
% Trucks	0.0%	0.0%	0.0%	0.0%	<b>0.0%</b>	0.0%	0.0%	0.0%	0.0%	<b>0.0%</b>	0.0%	0.0%	0.0%	0.0%	0.1%	0.4%	0.0%	0.0%	<b>0.3%</b>	0.0%	0.0%	0.0%	0.0%	0.0%	0.0%	0.0%	0.0%	0.0%	0.0%	0.0%	0.0%	<b>0.1%</b>	
Buses	0	70	2	0	<b>72</b>	0	0	0	0	0	0	0	0	0	9	47	0	0	<b>56</b>	0	0	0	0	0	0	0	0	<b>2</b>	0	0	<b>130</b>		
% Buses	0.0%	3.9%	0.3%	0.0%	<b>0.0%</b>	0.0%	0.0%	0.0%	0.0%	<b>0.0%</b>	0.0%	0.0%	0.0%	0.0%	1.2%	4.4%	0.0%	0.0%	<b>0.6%</b>	0.0%	0.0%	0.0%	0.0%	0.0%	0.0%	0.0%	0.0%	4.5%	0.0%	<b>0.0%</b>	0.0%	0.0%	<b>3.0%</b>
Pedestrians	0	0	0	0	<b>0</b>	2	0	0	0	0	0	0	5	4	0	0	0	0	<b>0</b>	0	0	0	0	0	0	0	0	<b>0</b>	4	6	<b>0</b>		
% Pedestrians	0.0%	0.0%	0.0%	0.0%	<b>0.0%</b>	100.0%	0.0%	0.0%	0.0%	<b>0.0%</b>	100.0%	80.0%	0.0%	0.0%	0.0%	0.0%	0.0%	0.0%	<b>0.0%</b>	0.0%	0.0%	0.0%	0.0%	0.0%	0.0%	0.0%	0.0%	<b>0.0%</b>	80.0%	85.7%	<b>0.0%</b>		
Bicycles on Crosswalk	0	0	0	0	<b>0</b>	0	0	0	0	0	0	0	1	0	0	0	0	0	<b>0</b>	0	0	0	0	0	0	0	0	<b>0</b>	1	1	<b>0</b>		
% Bicycles on Crosswalk	0.0%	0.0%	0.0%	0.0%	<b>0.0%</b>	0.0%	0.0%	0.0%	0.0%	<b>0.0%</b>	0.0%	0.0%	20.0%	0.0%	0.0%	0.0%	0.0%	0.0%	<b>0.0%</b>	0.0%	0.0%	0.0%	0.0%	0.0%	0.0%	0.0%	0.0%	<b>0.0%</b>	20.0%	14.3%	<b>0.0%</b>		

Project : VBH Malta NY  
 Site : Site 4  
 Location : 42.948550, -73.790036  
 Survey Date : 2021-04-28, Wednesday

### Turning Movement Data Plot

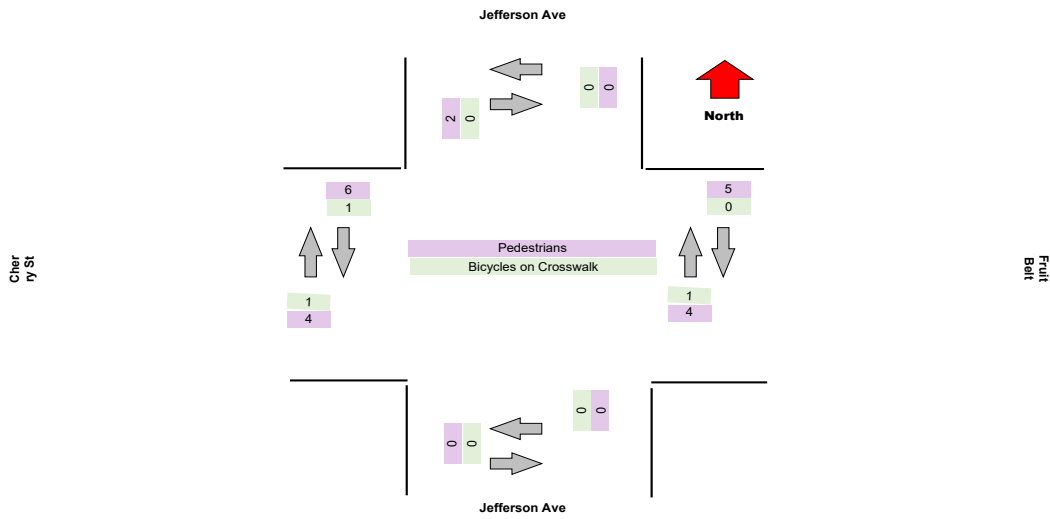
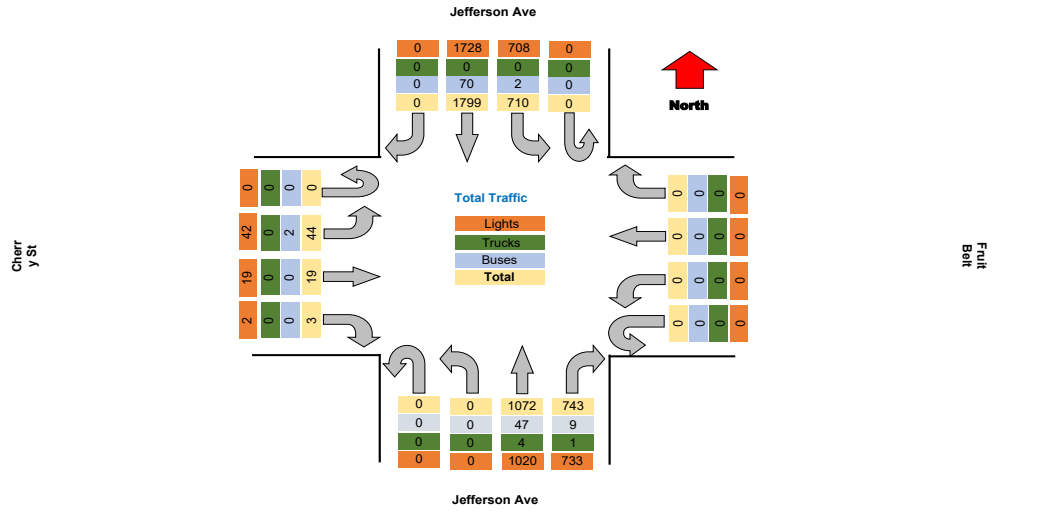

Project : VBH Malta NY  
Site : Site 4  
Location : 42.948550, -73.790036

TSTData.com

Survey Date : 2021-04-28, Wednesday

### Turning Movement Peak Hour Data (AM)

7:30:00 AM

Leg Direction	Jefferson Ave						Fruit Belt						Jefferson Ave						Cherry St						Total					
	Southbound			Northbound			Westbound			Eastbound			Northbound			Eastbound														
Start Time	Right	Thru	Left	U-Turn	App Total	Peds CW	Peds CCW	Right	Thru	Left	U-Turn	App Total	Peds CW	Peds CCW	Right	Thru	Left	U-Turn	App Total	Peds CW	Peds CCW	Right	Thru	Left	U-Turn	App Total	Peds CW	Peds CCW		
7:30:00 AM	0	94	30	0	124	0	0	0	0	0	0	0	0	0	37	76	0	0	113	0	0	0	3	2	0	5	0	1	242	
7:45:00 AM	0	109	34	0	143	0	0	0	0	0	0	0	0	0	40	102	0	0	142	0	0	0	0	4	0	4	0	0	289	
8:00:00 AM	0	104	32	0	136	0	0	0	0	0	0	0	1	0	41	89	0	0	131	0	0	0	1	5	0	6	0	1	273	
8:15:00 AM	0	125	28	0	153	0	0	0	0	0	0	1	0	0	35	63	0	0	99	0	0	0	0	2	0	2	1	0	254	
Grand Total	0	432	124	0	556	0	0	0	0	0	0	2	0	0	153	330	0	0	485	0	0	0	4	13	0	17	1	2	1088	
% Approach	0.0%	77.7%	22.3%	0.0%	0.0%	0.0%	0.0%	#DIV/0!	#DIV/0!	#DIV/0!	#DIV/0!	0.0%	0.0%	0.0%	31.5%	68.0%	0.0%	0.0%	0.0%	0.0%	0.0%	0.0%	0.0%	23.5%	76.5%	0.0%	0.0%	0.0%	0.0%	
% Total	0.0%	40.8%	11.7%	0.0%	52.6%	0.0%	0.0%	0.0%	0.0%	0.0%	0.0%	0.0%	0.0%	0.0%	14.5%	31.2%	0.0%	0.0%	45.8%	0.0%	0.0%	0.0%	0.0%	0.4%	1.2%	0.0%	1.6%	0.0%	0.0%	
PHF	0.000	0.864	0.912	0.000	0.908	0.000	0.000	0.000	0.000	0.000	0.000	0.000	0.000	0.000	0.933	0.809	0.000	0.000	0.854	0.000	0.000	0.000	0.000	0.333	0.650	0.000	0.708	0.000	0.000	0.915
Lights	0	403	124	0	527	0	0	0	0	0	0	0	0	0	147	308	0	0	455	0	0	0	4	12	0	16	0	0	998	
% Lights	0.0%	93.3%	100.0%	0.0%	94.8%	0.0%	0.0%	0.0%	0.0%	0.0%	0.0%	0.0%	0.0%	0.0%	96.1%	93.3%	0.0%	0.0%	93.8%	0.0%	0.0%	0.0%	100.0%	92.3%	0.0%	94.1%	0.0%	0.0%	94.3%	
Trucks	0	0	0	0	0	0	0	0	0	0	0	0	0	0	1	2	0	0	3	0	0	0	0	0	0	0	0	0	3	
% Trucks	0.0%	0.0%	0.0%	0.0%	0.0%	0.0%	0.0%	0.0%	0.0%	0.0%	0.0%	0.0%	0.0%	0.0%	0.7%	0.6%	0.0%	0.0%	0.6%	0.0%	0.0%	0.0%	0.0%	0.0%	0.0%	0.0%	0.0%	0.0%	0.3%	
Buses	0	29	0	0	29	0	0	0	0	0	0	0	0	0	5	20	0	0	25	0	0	0	0	1	0	1	0	0	55	
% Buses	0.0%	6.7%	0.0%	0.0%	0.0%	0.0%	0.0%	0.0%	0.0%	0.0%	0.0%	0.0%	0.0%	0.0%	3.3%	6.1%	0.0%	0.0%	0.0%	0.0%	0.0%	0.0%	0.0%	7.7%	0.0%	0.0%	0.0%	0.0%	5.2%	
Pedestrians	0	0	0	0	0	0	0	0	0	0	2	0	0	0	0	0	0	0	0	0	0	0	0	0	0	0	1	2	0	
% Pedestrians	0.0%	0.0%	0.0%	0.0%	0.0%	0.0%	0.0%	0.0%	0.0%	0.0%	100.0%	0.0%	0.0%	0.0%	0.0%	0.0%	0.0%	0.0%	0.0%	0.0%	0.0%	0.0%	0.0%	0.0%	0.0%	0.0%	0.0%	100.0%	100.0%	0.0%
Bicycles on Crosswalk	0	0	0	0	0	0	0	0	0	0	0	0	0	0	0	0	0	0	0	0	0	0	0	0	0	0	0	0	0	
% Bicycles on Crosswalk	0.0%	0.0%	0.0%	0.0%	0.0%	0.0%	0.0%	0.0%	0.0%	0.0%	0.0%	0.0%	0.0%	0.0%	0.0%	0.0%	0.0%	0.0%	0.0%	0.0%	0.0%	0.0%	0.0%	0.0%	0.0%	0.0%	0.0%	0.0%	0.0%	

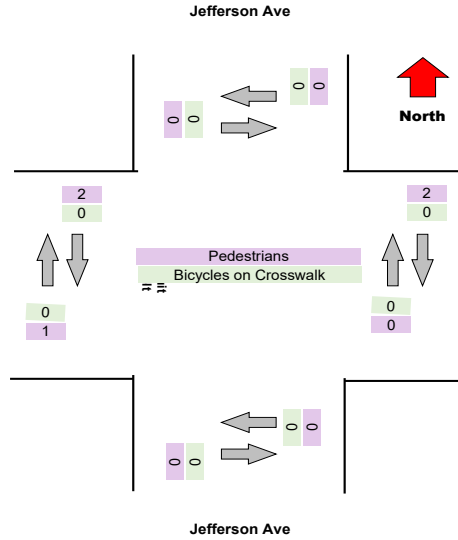
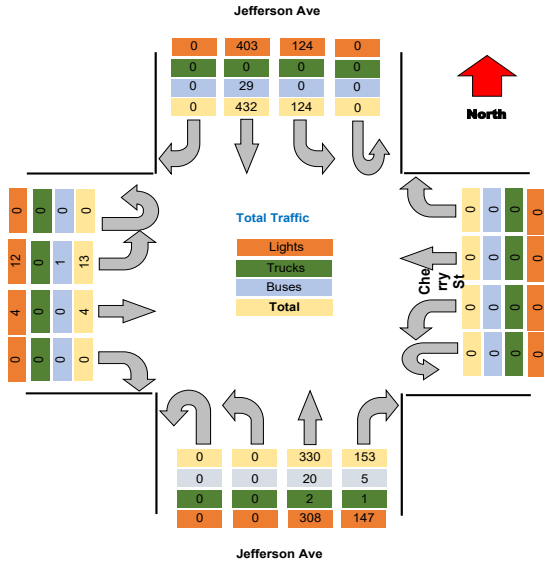



**Turning Movement Peak Hour Data (PM)**

4:15:00 PM

Leg Direction	Jefferson Ave								Fruit Belt								Jefferson Ave								Cherry St								Total
	Southbound				Westbound				Northbound				Eastbound				Southbound				Westbound				Northbound				Eastbound				
	Right	Thru	Left	U-Turn	App Total	Peds CW	Peds CCW		Right	Thru	Left	U-Turn	App Total	Peds CW	Peds CCW		Right	Thru	Left	U-Turn	App Total	Peds CW	Peds CCW		Right	Thru	Left	U-Turn	App Total	Peds CW	Peds CCW		
4:15:00 PM	0	169	72	0	241	2	0	0	0	0	0	0	0	0	0	2	62	80	0	0	142	0	0	0	0	1	3	0	4	0	0	0	387
4:30:00 PM	0	129	70	0	199	0	0	0	0	0	0	0	0	2	0	0	81	76	0	0	157	0	0	0	0	1	5	0	6	0	0	0	362
4:45:00 PM	0	146	65	0	211	0	0	0	0	0	0	0	0	0	0	0	65	68	0	0	133	0	0	0	0	2	2	0	4	2	3	0	348
5:00:00 PM	0	135	76	0	211	0	0	0	0	0	0	0	0	0	0	0	70	73	0	0	143	0	0	0	0	0	3	0	3	1	1	0	357
Grand Total	0	579	283	0	862	2	0	0	0	0	0	0	2	2	0	0	278	297	0	0	575	0	0	0	0	4	13	0	17	3	4	0	1454
% Approach	0.0%	67.2%	32.8%	0.0%	0.0%	0.0%	0.0%	0.0%	#DIV/0!	#DIV/0!	#DIV/0!	#DIV/0!	0.0%	0.0%	0.0%	0.0%	48.3%	51.7%	0.0%	0.0%	0.0%	0.0%	0.0%	0.0%	0.0%	23.5%	76.5%	0.0%	0.0%	0.0%	0.0%	0.0%	
% Total	0.0%	39.8%	19.5%	0.0%	59.3%	0.0%	0.0%	0.0%	0.0%	0.0%	0.0%	0.0%	0.0%	0.0%	0.0%	0.0%	19.1%	20.4%	0.0%	0.0%	39.5%	0.0%	0.0%	0.0%	0.0%	0.3%	0.9%	0.0%	1.2%	0.0%	0.0%	0.0%	
PHF	0.000	0.857	0.931	0.000	0.894	0.000	0.000	0.000	0.000	0.000	0.000	0.000	0.000	0.000	0.000	0.000	0.858	0.928	0.000	0.000	0.816	0.000	0.000	0.000	0.000	0.500	0.650	0.000	0.708	0.000	0.000	0.000	0.939
Lights	0	562	283	0	845	0	0	0	0	0	0	0	0	0	0	0	278	285	0	0	561	0	0	0	0	4	13	0	17	0	0	0	1423
% Lights	0.0%	97.1%	100.0%	0.0%	98.0%	0.0%	0.0%	0.0%	0.0%	0.0%	0.0%	0.0%	0.0%	0.0%	0.0%	0.0%	99.3%	96.0%	0.0%	0.0%	97.6%	0.0%	0.0%	0.0%	0.0%	100.0%	100.0%	0.0%	100.0%	0.0%	0.0%	0.0%	97.9%
Trucks	0	0	0	0	0	0	0	0	0	0	0	0	0	0	0	0	0	1	0	0	1	0	0	0	0	0	0	0	0	0	0	0	1
% Trucks	0.0%	0.0%	0.0%	0.0%	0.0%	0.0%	0.0%	0.0%	0.0%	0.0%	0.0%	0.0%	0.0%	0.0%	0.0%	0.0%	0.0%	0.3%	0.0%	0.0%	0.2%	0.0%	0.0%	0.0%	0.0%	0.0%	0.0%	0.0%	0.0%	0.0%	0.0%	0.0%	0.1%
Buses	0	17	0	0	17	0	0	0	0	0	0	0	0	0	0	0	2	10	0	0	12	0	0	0	0	0	0	0	0	0	0	0	29
% Buses	0.0%	2.9%	0.0%	0.0%	0.0%	0.0%	0.0%	0.0%	0.0%	0.0%	0.0%	0.0%	0.0%	0.0%	0.0%	0.0%	0.7%	3.4%	0.0%	0.0%	0.0%	0.0%	0.0%	0.0%	0.0%	0.0%	0.0%	0.0%	0.0%	0.0%	0.0%	0.0%	2.0%
Pedestrians	0	0	0	0	0	2	0	0	0	0	0	0	2	3	0	0	0	0	0	0	0	0	0	0	0	0	0	0	0	3	4	0	0
% Pedestrians	0.0%	0.0%	0.0%	0.0%	0.0%	100.0%	0.0%	0.0%	0.0%	0.0%	0.0%	0.0%	0.0%	100.0%	100.0%	0.0%	0.0%	0.0%	0.0%	0.0%	0.0%	0.0%	0.0%	0.0%	0.0%	0.0%	0.0%	0.0%	0.0%	100.0%	100.0%	0.0%	0.0%
Bicycles on Crosswalk	0	0	0	0	0	0	0	0	0	0	0	0	0	0	0	0	0	0	0	0	0	0	0	0	0	0	0	0	0	0	0	0	0
% Bicycles on Crosswalk	0.0%	0.0%	0.0%	0.0%	0.0%	0.0%	0.0%	0.0%	0.0%	0.0%	0.0%	0.0%	0.0%	0.0%	0.0%	0.0%	0.0%	0.0%	0.0%	0.0%	0.0%	0.0%	0.0%	0.0%	0.0%	0.0%	0.0%	0.0%	0.0%	0.0%	0.0%	0.0%	0.0%

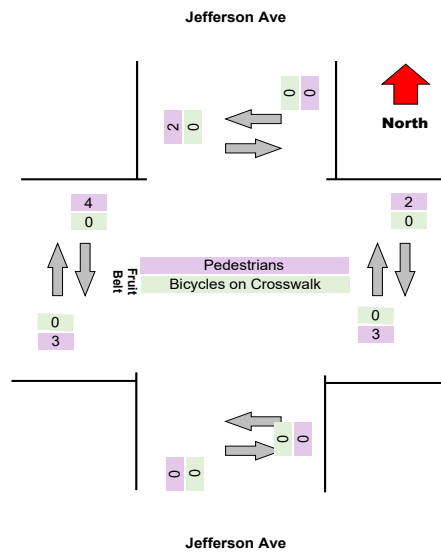
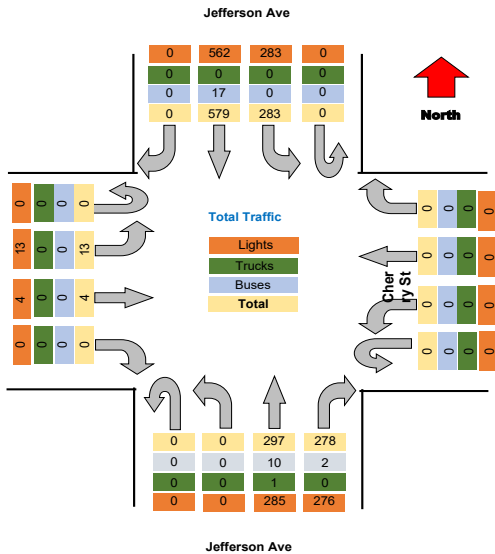



### Turning Movement Data Plot

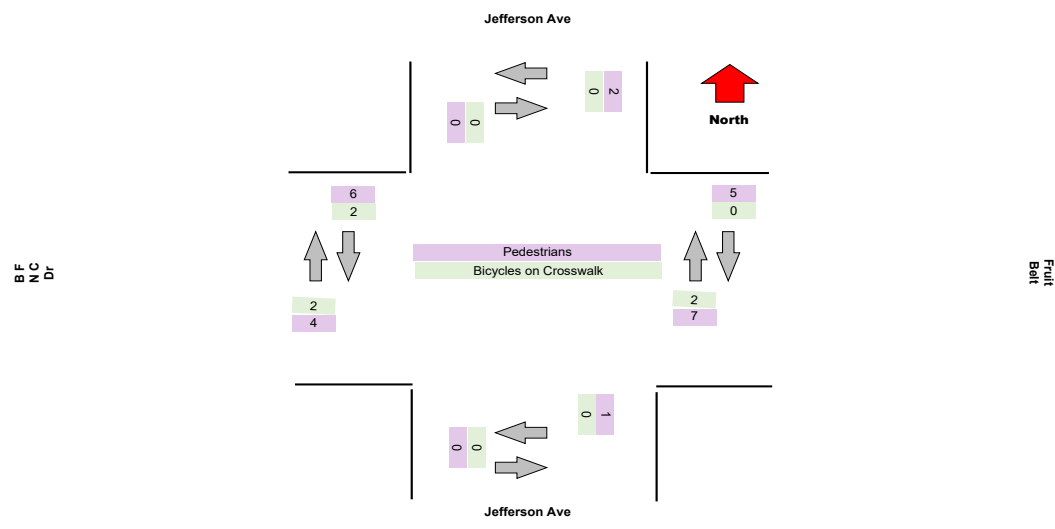
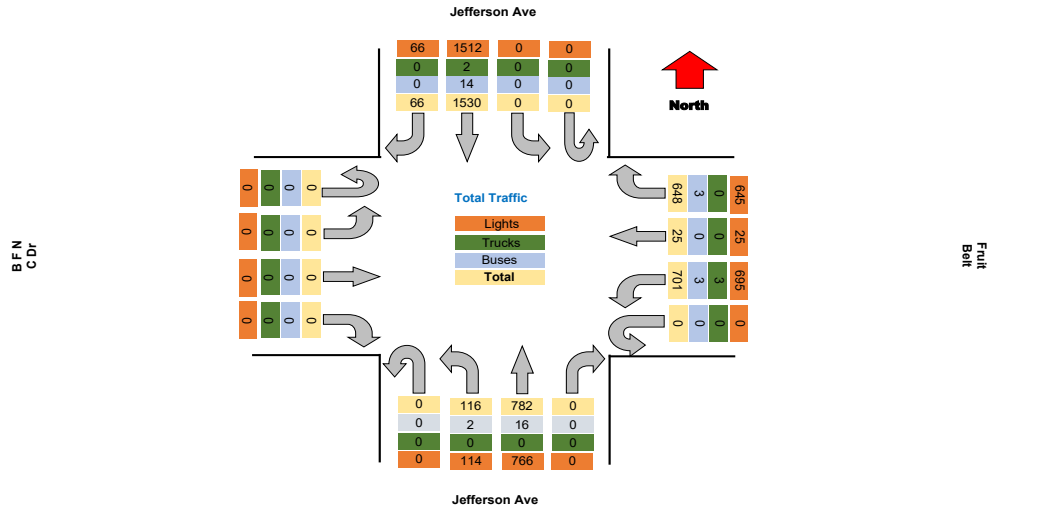

**Turning Movement Peak Hour Data (AM)**

7:30:00 AM

Leg Direction	Jefferson Ave						Fruit Belt						Jefferson Ave						B F N C Dr						Total				
	Southbound			Westbound			Northbound			Eastbound			Southbound			Westbound			Northbound			Eastbound							
Start Time	Right	Thru	Left	U-Turn	App Total	Peds CW	Peds CCW	Right	Thru	Left	U-Turn	App Total	Peds CW	Peds CCW	Right	Thru	Left	U-Turn	App Total	Peds CW	Peds CCW	Right	Thru	Left	U-Turn	App Total	Peds CW	Peds CCW	
7:30:00 AM	2	47	0	0	49	0	0	71	0	33	0	104	0	0	0	48	9	0	57	0	0	0	0	0	0	0	0	0	210
7:45:00 AM	3	45	0	0	48	0	0	74	1	43	0	118	0	0	0	43	5	0	48	0	0	0	0	0	0	0	0	1	214
8:00:00 AM	2	65	0	0	67	0	0	67	0	39	0	106	0	0	0	49	8	0	57	0	0	0	0	0	0	0	0	1	230
8:15:00 AM	3	61	0	0	64	0	0	56	2	38	0	97	0	0	0	37	9	0	46	0	0	0	0	0	0	0	0	1	209
<b>Grand Total</b>	10	218	0	0	228	0	0	268	3	152	0	423	0	0	0	177	31	0	210	0	0	0	0	0	0	0	0	2	863
% Approach	4.4%	95.6%	0.0%	0.0%	0.0%	0.0%	0.0%	63.1%	0.7%	36.0%	0.0%	0.0%	0.0%	0.0%	0.0%	84.3%	14.8%	0.0%	0.0%	0.0%	0.0%	0.0%	0.0%	0.0%	0.0%	0.0%	0.0%	0.0%	0.0%
% Total	1.2%	25.3%	0.0%	0.0%	26.4%	0.0%	0.0%	31.1%	0.3%	17.7%	0.0%	49.2%	0.0%	0.0%	0.0%	20.5%	3.6%	0.0%	24.3%	0.0%	0.0%	0.0%	0.0%	0.0%	0.0%	0.0%	0.0%	0.0%	
PHF	0.833	0.838	0.000	0.000	0.851	0.000	0.000	0.905	0.375	0.890	0.000	0.900	0.000	0.000	0.000	0.903	0.861	0.000	0.821	0.000	0.000	0.000	0.000	0.000	0.000	0.000	0.000	0.938	
Lights	10	213	0	0	223	0	0	268	3	152	0	423	0	0	0	175	30	0	205	0	0	0	0	0	0	0	0	0	851
% Lights	100.0%	97.7%	0.0%	0.0%	97.8%	0.0%	0.0%	100.0%	100.0%	99.3%	0.0%	99.5%	0.0%	0.0%	0.0%	98.0%	96.8%	0.0%	97.6%	0.0%	0.0%	0.0%	0.0%	0.0%	0.0%	0.0%	0.0%	0.0%	98.6%
Trucks	0	0	0	0	0	0	0	0	0	0	0	0	0	0	0	0	0	0	0	0	0	0	0	0	0	0	0	0	0
% Trucks	0.0%	0.0%	0.0%	0.0%	0.0%	0.0%	0.0%	0.0%	0.0%	0.0%	0.0%	0.0%	0.0%	0.0%	0.0%	0.0%	0.0%	0.0%	0.0%	0.0%	0.0%	0.0%	0.0%	0.0%	0.0%	0.0%	0.0%	0.0%	0.0%
Buses	0	5	0	0	5	0	0	0	0	1	0	1	0	0	0	2	1	0	3	0	0	0	0	0	0	0	0	0	9
% Buses	0.0%	2.3%	0.0%	0.0%	0.0%	0.0%	0.0%	0.0%	0.0%	0.7%	0.0%	0.0%	0.0%	0.0%	0.0%	1.1%	3.2%	0.0%	0.0%	0.0%	0.0%	0.0%	0.0%	0.0%	0.0%	0.0%	0.0%	0.0%	1.0%
Pedestrians	0	0	0	0	0	0	0	0	0	0	0	0	1	1	0	0	0	0	0	0	0	0	0	0	0	0	0	1	2
% Pedestrians	0.0%	0.0%	0.0%	0.0%	0.0%	0.0%	100.0%	0.0%	0.0%	0.0%	0.0%	0.0%	100.0%	100.0%	0.0%	0.0%	0.0%	0.0%	0.0%	0.0%	0.0%	0.0%	0.0%	0.0%	0.0%	0.0%	0.0%	50.0%	100.0%
Bicycles on Crosswalk	0	0	0	0	0	0	0	0	0	0	0	0	0	0	0	0	0	0	0	0	0	0	0	0	0	0	0	1	0
% Bicycles on Crosswalk	0.0%	0.0%	0.0%	0.0%	0.0%	0.0%	0.0%	0.0%	0.0%	0.0%	0.0%	0.0%	0.0%	0.0%	0.0%	0.0%	0.0%	0.0%	0.0%	0.0%	0.0%	0.0%	0.0%	0.0%	0.0%	0.0%	0.0%	50.0%	0.0%

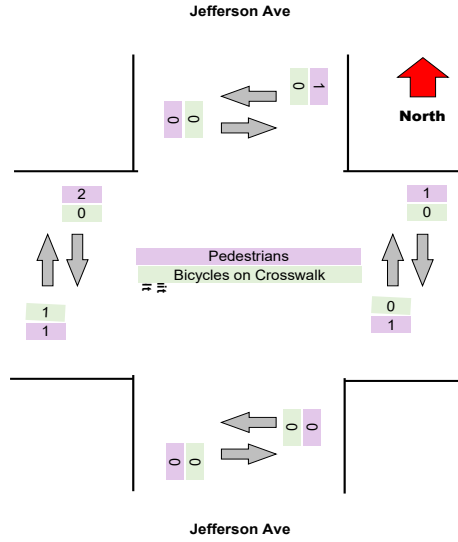
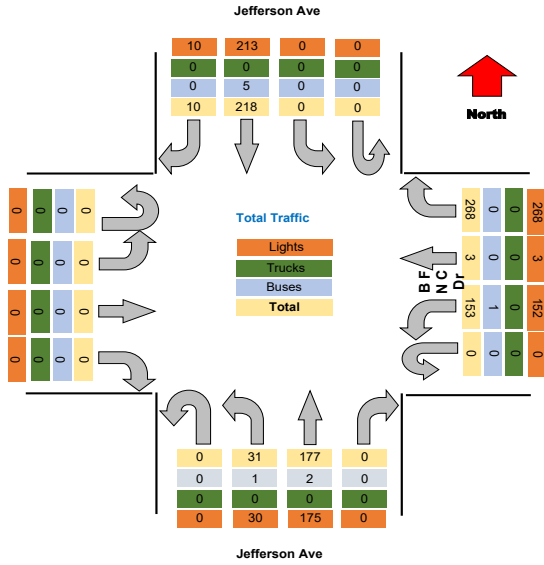

**Turning Movement Peak Hour Data (PM)**

4:15:00 PM

Leg Direction	Jefferson Ave										Fruit Belt										Jefferson Ave										B F N C Dr										Total										
	Southbound					Westbound					Northbound					Eastbound					Southbound					Westbound					Northbound					Eastbound															
	Right	Thru	Left	U-Turn	App Total	Right	Thru	Left	U-Turn	App Total	Right	Thru	Left	U-Turn	App Total	Right	Thru	Left	U-Turn	App Total	Right	Thru	Left	U-Turn	App Total	Right	Thru	Left	U-Turn	App Total	Right	Thru	Left	U-Turn	App Total	Right	Thru	Left	U-Turn	App Total		Right	Thru	Left	U-Turn	App Total					
4:15:00 PM	5	146	0	0	151	33	2	62	0	97	0	48	5	0	53	0	0	0	0	0	0	0	0	0	0	0	0	0	0	0	0	0	0	0	0	0	0	0	0	0	0	0	0	0	0	301					
4:30:00 PM	7	171	0	0	178	25	5	53	0	83	0	0	0	0	0	0	48	5	0	53	0	0	0	0	0	0	0	0	0	0	0	0	0	0	0	0	0	0	0	0	0	0	0	0	0	314					
4:45:00 PM	4	153	0	0	157	24	1	62	0	87	0	0	0	0	0	0	67	11	0	78	0	0	0	0	0	0	0	0	0	0	0	0	0	0	0	0	2	1	0	3	0	0	0	0	0	295					
5:00:00 PM	4	147	0	0	151	20	1	43	0	64	0	0	0	0	0	0	77	3	0	80	0	0	0	0	0	0	0	0	0	0	0	0	0	0	0	0	0	0	0	0	0	3	2	0	5	0	0	0	0	0	1232
Grand Total	20	617	0	0	637	102	9	220	0	331	0	0	0	0	0	0	235	24	0	259	0	0	0	0	0	0	0	0	0	0	0	0	0	0	0	0	0	0	0	0	0	3	2	0	5	0	0	0	0	0	1219
% Approach	3.1%	96.9%	0.0%	0.0%	0.0%	30.8%	2.7%	66.5%	0.0%	0.0%	0.0%	90.9%	9.1%	0.0%	0.0%	0.0%	97.0%	100.0%	0.0%	98.1%	0.0%	0.0%	0.0%	0.0%	0.0%	0.0%	0.0%	0.0%	0.0%	0.0%	0.0%	0.0%	0.0%	0.0%	0.0%	0.0%	0.0%	0.0%	0.0%	0.0%	0.0%	0.0%	0.0%	0.0%	0.0%	0.8%					
% Total	1.6%	50.1%	0.0%	0.0%	51.7%	8.3%	0.7%	17.9%	0.0%	26.9%	0.0%	19.5%	1.9%	0.0%	21.4%	0.0%	0.0%	0.0%	0.0%	0.0%	0.0%	0.0%	0.0%	0.0%	0.0%	0.0%	0.0%	0.0%	0.0%	0.0%	0.0%	0.0%	0.0%	0.0%	0.0%	0.0%	0.0%	0.0%	0.0%	0.0%	0.0%	0.0%	0.0%	0.0%	0.0%	0.1%					
PHF	0.714	0.902	0.000	0.000	0.895	0.773	0.450	0.887	0.000	0.853	0.000	0.779	0.545	0.000	0.825	0.000	0.000	0.000	0.000	0.000	0.000	0.000	0.000	0.000	0.000	0.000	0.000	0.000	0.000	0.000	0.000	0.000	0.000	0.000	0.000	0.000	0.000	0.000	0.000	0.000	0.000	0.000	0.000	0.000	0.000	0.957					
Lights	20	610	0	0	630	101	9	220	0	330	0	0	0	0	0	0	235	24	0	259	0	0	0	0	0	0	0	0	0	0	0	0	0	0	0	0	0	0	0	0	0	0	0	0	0	0	0	0	0	0	1219
% Lights	100.0%	98.9%	0.0%	0.0%	98.9%	99.0%	100.0%	100.0%	0.0%	99.7%	0.0%	0.0%	0.0%	0.0%	0.0%	0.0%	97.0%	100.0%	0.0%	98.1%	0.0%	0.0%	0.0%	0.0%	0.0%	0.0%	0.0%	0.0%	0.0%	0.0%	0.0%	0.0%	0.0%	0.0%	0.0%	0.0%	0.0%	0.0%	0.0%	0.0%	0.0%	0.0%	0.0%	0.0%	0.0%	98.9%					
Trucks	0	1	0	0	1	0	0	0	0	0	0	0	0	0	0	0	0	0	0	0	0	0	0	0	0	0	0	0	0	0	0	0	0	0	0	0	0	0	0	0	0	0	0	0	0	1					
% Trucks	0.0%	0.2%	0.0%	0.0%	0.2%	0.0%	0.0%	0.0%	0.0%	0.0%	0.0%	0.0%	0.0%	0.0%	0.0%	0.0%	0.0%	0.0%	0.0%	0.0%	0.0%	0.0%	0.0%	0.0%	0.0%	0.0%	0.0%	0.0%	0.0%	0.0%	0.0%	0.0%	0.0%	0.0%	0.0%	0.0%	0.0%	0.0%	0.0%	0.0%	0.0%	0.0%	0.0%	0.0%	0.0%	0.1%					
Buses	0	4	0	0	4	1	0	0	0	1	0	5	0	0	5	0	0	0	0	0	0	0	0	0	0	0	0	0	0	0	0	0	0	0	0	0	0	0	0	0	0	0	0	0	0	10					
% Buses	0.0%	0.6%	0.0%	0.0%	0.6%	1.0%	0.0%	0.0%	0.0%	0.3%	0.0%	2.1%	0.0%	0.0%	0.0%	0.0%	0.0%	0.0%	0.0%	0.0%	0.0%	0.0%	0.0%	0.0%	0.0%	0.0%	0.0%	0.0%	0.0%	0.0%	0.0%	0.0%	0.0%	0.0%	0.0%	0.0%	0.0%	0.0%	0.0%	0.0%	0.8%										
Pedestrians	0	0	0	0	0	0	0	0	0	0	0	0	0	0	0	0	0	0	0	0	0	0	0	0	0	0	0	0	0	0	0	0	0	0	0	0	0	0	0	0	2	1	0	0	3	0					
% Pedestrians	0.0%	0.0%	0.0%	0.0%	0.0%	0.0%	0.0%	0.0%	0.0%	0.0%	0.0%	0.0%	0.0%	0.0%	0.0%	0.0%	0.0%	0.0%	0.0%	0.0%	0.0%	0.0%	0.0%	0.0%	0.0%	0.0%	0.0%	0.0%	0.0%	0.0%	0.0%	0.0%	0.0%	0.0%	0.0%	0.0%	0.0%	0.0%	0.0%	0.0%	50.2%	50.0%	0.0%	0.0%	0.0%	0.0%					
Bicycles on Crosswalk	0	0	0	0	0	0	0	0	0	0	0	0	0	0	0	0	0	0	0	0	0	0	0	0	0	0	0	0	0	0	0	0	0	0	0	0	0	0	0	0	1	1	0	0	2	0					
% Bicycles on Crosswalk	0.0%	0.0%	0.0%	0.0%	0.0%	0.0%	0.0%	0.0%	0.0%	0.0%	0.0%	0.0%	0.0%	0.0%	0.0%	0.0%	0.0%	0.0%	0.0%	0.0%	0.0%	0.0%	0.0%	0.0%	0.0%	0.0%	0.0%	0.0%	0.0%	0.0%	0.0%	0.0%	0.0%	0.0%	0.0%	0.0%	33.3%	50.0%	0.0%	0.0%	0.0%	0.0%	0.0%	0.0%	0.0%	0.0%					

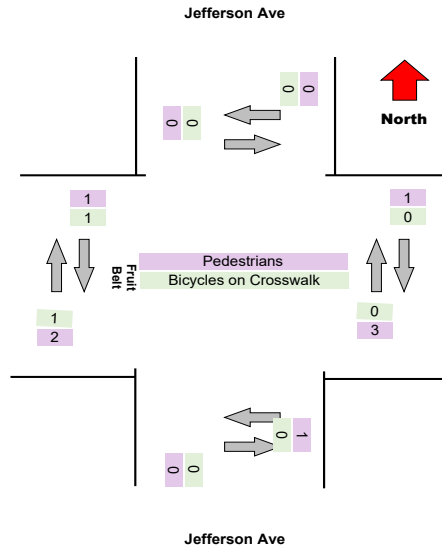
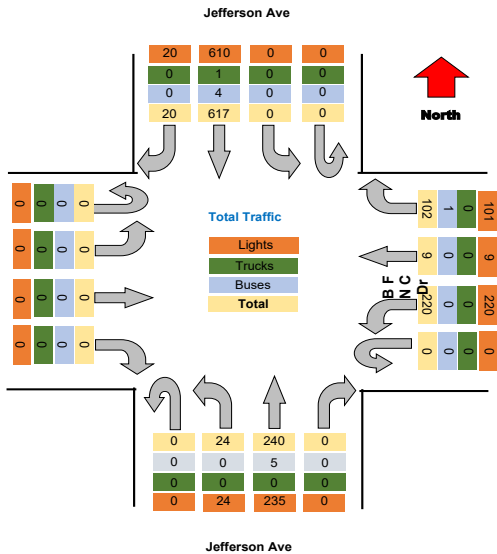

Project : VBH Malta NY  
Site : Site 4  
Location : 42.948550, -73.790036

TSTData.com

Survey Date : 2021-04-28, Wednesday

Project	LaBella
Project Code	LaBella
Site Name	11
Legs and Movements	All Processed Legs & Move
Bin Size	15 minutes
Survey Date	2021-11-03, Wednesday
Location	11
Latitude and Longitude	42.897816, -78.853982

	Start	End	PHF
Forced Peak AM	2021/11/03 07:30:00	2021/11/03 08:30:00	0.87
Forced Peak PM	2021/11/03 16:30:00	2021/11/03 17:30:00	0.92
AM Peak	2021/11/03 07:30:00	2021/11/03 08:30:00	0.87
PM Peak	2021/11/03 16:15:00	2021/11/03 17:15:00	0.93

### Turning Movement Data

Leg Direction	Jefferson Ave						Fruit Belt						Jefferson Ave						B F N C Dr						Total					
	Southbound			Westbound			Northbound			Eastbound			Right			Left			U-Turn											
Start Time	Right	Thru	Left	U-Turn	App Total	Peds CW	Peds CCW	Right	Thru	Left	U-Turn	App Total	Peds CW	Peds CCW	Right	Thru	Left	U-Turn	App Total	Peds CW	Peds CCW	Right	Thru	Left	U-Turn	App Total	Peds CW	Peds CCW		
6:30:00 AM	1	31	0	0	32	0	0	45	0	22	0	67	0	0	0	36	4	0	40	0	0	0	0	0	0	0	0	0	139	
6:45:00 AM	3	49	0	0	52	0	0	70	0	30	0	100	0	0	0	44	6	0	50	0	0	0	0	0	0	0	0	1	202	
Hourly Total	4	80	0	0	84	0	0	115	0	52	0	167	0	0	0	88	10	0	98	0	0	0	0	0	0	0	0	2	341	
7:00:00 AM	1	60	0	0	61	0	0	45	1	25	0	71	0	0	0	47	6	0	53	0	0	0	0	0	0	0	0	1	185	
7:15:00 AM	2	56	0	0	58	0	0	79	4	44	0	127	0	0	0	54	6	0	60	0	0	0	0	0	0	0	1	245		
7:30:00 AM	5	67	0	0	72	0	0	86	3	51	0	140	0	0	0	60	7	0	67	0	0	1	0	0	0	1	0	280		
7:45:00 AM	3	90	0	0	93	0	0	104	10	55	0	169	0	0	0	90	16	0	106	1	0	0	0	0	0	0	1	0	368	
Hourly Total	11	273	0	0	284	0	0	314	18	175	0	507	0	0	0	251	35	0	286	1	0	1	0	0	0	1	2	5	1078	
8:00:00 AM	6	115	0	0	121	0	0	90	6	59	0	155	0	0	0	69	7	0	76	0	0	0	0	0	0	0	0	0	362	
8:15:00 AM	4	83	0	0	87	0	0	70	1	61	0	132	0	0	0	52	6	0	58	0	0	0	0	0	0	0	0	0	277	
Hourly Total	10	198	0	0	208	0	0	160	7	120	0	287	0	0	0	121	13	0	134	0	0	0	0	0	0	0	0	0	629	
4:00:00 PM	9	168	0	0	177	0	0	29	3	59	0	91	0	0	0	80	3	0	83	0	0	0	0	0	0	0	2	4	351	
4:15:00 PM	6	184	0	0	190	0	0	23	4	60	0	87	0	0	0	72	10	0	82	0	0	0	0	0	0	0	2	1	359	
4:30:00 PM	4	192	0	0	196	0	0	27	3	45	0	75	0	0	0	72	11	0	83	0	0	0	0	0	0	0	1	0	354	
4:45:00 PM	3	156	0	0	159	0	0	16	2	64	0	82	0	0	0	67	8	0	75	0	0	0	0	0	0	0	0	0	306	
Hourly Total	22	690	0	0	712	0	0	95	12	228	0	335	0	0	0	291	32	0	323	0	0	0	0	0	0	0	0	5	5	1370
5:00:00 PM	4	164	0	0	168	0	0	22	2	40	0	64	0	1	0	76	10	0	86	0	0	0	0	0	0	0	0	0	318	
5:15:00 PM	2	155	0	0	157	0	0	20	1	69	0	90	1	0	0	72	4	0	76	0	0	0	0	0	0	0	3	1	323	
5:30:00 PM	8	108	0	0	116	0	0	17	4	58	0	79	1	0	0	66	9	0	75	0	0	0	0	0	0	0	1	1	270	
5:45:00 PM	4	122	0	0	126	0	0	24	3	44	0	71	1	0	0	52	1	0	53	0	0	0	0	0	0	0	0	0	280	
Hourly Total	18	549	0	0	567	0	0	83	10	211	0	304	3	1	0	266	24	0	290	0	0	0	0	0	0	0	4	2	1161	
Grand Total	65	1790	0	0	1855	0	0	767	47	786	0	1600	3	1	0	1009	114	0	1123	1	0	1	0	0	0	1	13	14	4579	
% Approach	3.5%	96.5%	0.0%	0.0%	0.0%	0.0%	0.0%	47.9%	2.9%	49.1%	0.0%	0.0%	0.0%	0.0%	0.0%	89.8%	10.2%	0.0%	0.0%	0.0%	0.0%	0.0%	0.0%	0.0%	0.0%	0.0%	0.0%	0.0%	0.0%	
% Total	1.4%	39.1%	0.0%	0.0%	40.5%	0.0%	0.0%	16.8%	1.0%	17.2%	0.0%	34.9%	0.0%	0.0%	0.0%	22.0%	2.5%	0.0%	24.5%	0.0%	0.0%	0.0%	0.0%	0.0%	0.0%	0.0%	0.0%	0.0%	0.0%	
Lights	62	1728	0	0	1790	0	0	763	45	773	0	1581	0	0	0	964	105	0	1069	0	0	0	0	0	0	0	0	0	4441	
% Lights	95.4%	96.5%	0.0%	0.0%	96.5%	0.0%	0.0%	99.5%	95.7%	98.3%	0.0%	99.8%	0.0%	0.0%	0.0%	95.5%	92.1%	0.0%	95.2%	0.0%	0.0%	0.0%	0.0%	0.0%	0.0%	0.0%	0.0%	0.0%	97.0%	
Trucks	0	1	0	0	1	0	0	1	0	2	0	3	0	0	0	0	1	0	1	0	0	0	0	0	0	0	0	0	5	
% Trucks	0.0%	0.1%	0.0%	0.0%	0.1%	0.0%	0.0%	0.1%	0.0%	0.3%	0.0%	0.2%	0.0%	0.0%	0.0%	0.0%	0.9%	0.0%	0.1%	0.0%	0.0%	0.0%	0.0%	0.0%	0.0%	0.0%	0.0%	0.0%	0.1%	
Buses	3	61	0	0	64	0	0	3	2	11	0	16	0	0	0	45	8	0	53	0	0	0	0	0	0	0	0	0	133	
% Buses	4.6%	3.4%	0.0%	0.0%	0.0%	0.0%	0.0%	0.0%	4.3%	1.4%	0.0%	0.0%	0.0%	0.0%	0.0%	4.5%	7.0%	0.0%	0.0%	0.0%	0.0%	0.0%	0.0%	0.0%	0.0%	0.0%	0.0%	0.0%	2.9%	
Pedestrians	0	0	0	0	0	0	0	0	0	0	0	0	2	1	0	0	0	0	0	1	0	0	0	0	0	0	7	12	0	
% Pedestrians	0.0%	0.0%	0.0%	0.0%	0.0%	0.0%	0.0%	0.0%	0.0%	0.0%	0.0%	0.0%	66.7%	100.0%	0.0%	0.0%	0.0%	0.0%	0.0%	100.0%	0.0%	0.0%	0.0%	0.0%	0.0%	0.0%	0.0%	63.8%	85.7%	0.0%
Bicycles on Crosswalk	0	0	0	0	0	0	0	0	0	0	0	0	1	0	0	0	0	0	0	0	0	0	0	0	0	0	4	2	0	
% Bicycles on Crosswalk	0.0%	0.0%	0.0%	0.0%	0.0%	0.0%	0.0%	0.0%	0.0%	0.0%	0.0%	0.0%	33.3%	0.0%	0.0%	0.0%	0.0%	0.0%	0.0%	0.0%	0.0%	0.0%	0.0%	0.0%	0.0%	0.0%	0.0%	36.4%	14.3%	0.0%

Project : VBH Malta NY  
 Site : Site 4  
 Location : 42.948550, -73.790036  
 Survey Date : 2021-04-28, Wednesday

### Turning Movement Data Plot

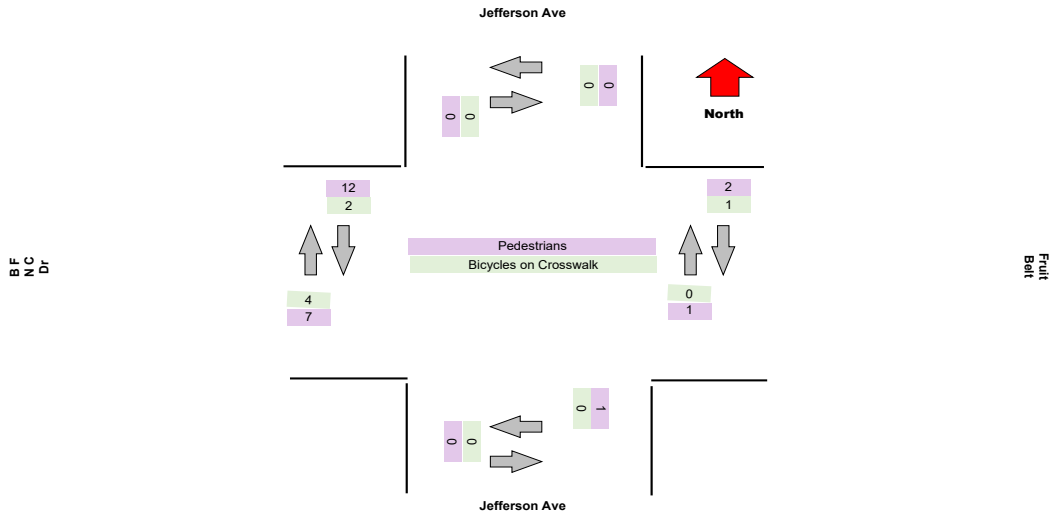
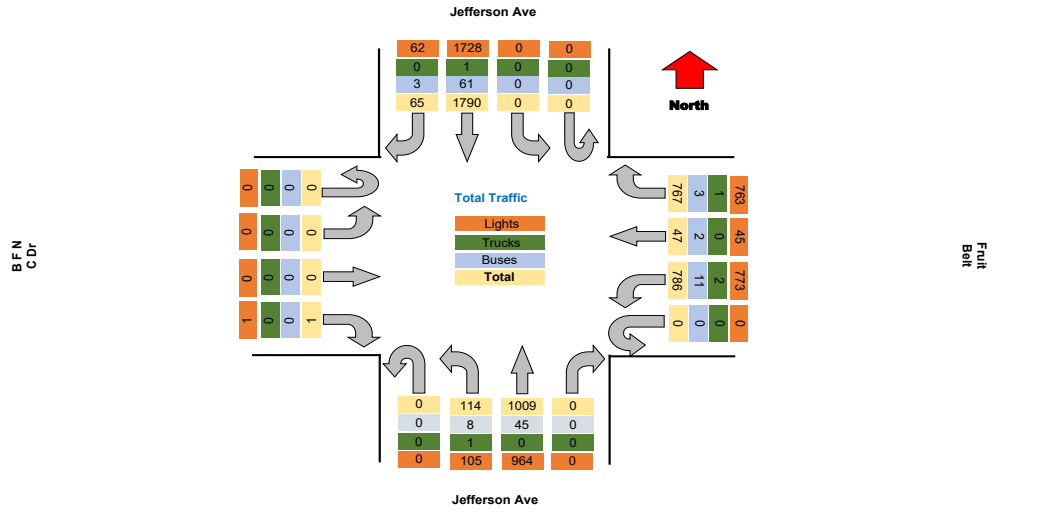

**Turning Movement Peak Hour Data (AM)**

7:30:00 AM

Leg Direction	Jefferson Ave					Fruit Belt					Jefferson Ave					B F N C Dr					Total					
	Right	Thru	Left	U-Turn	App Total	Peds CW	Peds CCW	Right	Thru	Left	U-Turn	App Total	Peds CW	Peds CCW	Right	Thru	Left	U-Turn	App Total	Peds CW		Peds CCW				
7:30:00 AM	5	67	0	0	72	0	0	86	3	51	0	140	0	0	0	60	7	0	67	0	0	1	0	2	280	
7:45:00 AM	3	90	0	0	93	0	0	104	10	55	0	169	0	0	0	90	16	0	106	1	0	0	0	1	0	368
8:00:00 AM	6	115	0	0	121	0	0	90	6	59	0	155	0	0	0	69	7	0	76	0	0	0	0	0	352	
8:15:00 AM	4	83	0	0	87	0	0	70	1	61	0	132	0	0	0	52	6	0	58	0	0	0	0	0	277	
<b>Grand Total</b>	<b>18</b>	<b>355</b>	<b>0</b>	<b>0</b>	<b>373</b>	<b>0</b>	<b>0</b>	<b>350</b>	<b>20</b>	<b>226</b>	<b>0</b>	<b>536</b>	<b>0</b>	<b>0</b>	<b>0</b>	<b>271</b>	<b>36</b>	<b>0</b>	<b>307</b>	<b>1</b>	<b>0</b>	<b>0</b>	<b>1</b>	<b>1</b>	<b>2</b>	<b>1277</b>
<b>% Approach</b>	4.8%	95.2%	0.0%	0.0%	0.0%	0.0%	0.0%	58.7%	3.4%	37.9%	0.0%	0.0%	0.0%	0.0%	0.0%	88.3%	11.7%	0.0%	0.0%	0.0%	0.0%	0.0%	0.0%	0.0%	0.0%	0.0%
<b>% Total</b>	1.4%	27.8%	0.0%	0.0%	28.2%	0.0%	0.0%	27.4%	1.6%	17.7%	0.0%	46.7%	0.0%	0.0%	0.0%	21.2%	2.8%	0.0%	24.0%	0.0%	0.0%	0.1%	0.0%	0.0%	0.0%	
<b>PHF</b>	0.750	0.772	0.000	0.000	0.771	0.000	0.000	0.841	0.500	0.926	0.000	0.882	0.000	0.000	0.000	0.753	0.563	0.000	0.724	0.000	0.000	0.250	0.000	0.000	0.250	0.868
<b>Lights</b>	16	327	0	0	343	0	0	350	19	219	0	588	0	0	0	253	31	0	284	0	0	0	1	0	0	1216
<b>% Lights</b>	88.9%	92.1%	0.0%	0.0%	92.0%	0.0%	0.0%	100.0%	95.0%	96.9%	0.0%	98.7%	0.0%	0.0%	0.0%	93.4%	86.1%	0.0%	92.5%	0.0%	0.0%	100.0%	0.0%	0.0%	100.0%	95.2%
<b>Trucks</b>	0	0	0	0	0	0	0	0	0	2	0	2	0	0	0	0	0	0	0	0	0	0	0	0	0	2
<b>% Trucks</b>	0.0%	0.0%	0.0%	0.0%	0.0%	0.0%	0.0%	0.0%	0.0%	0.9%	0.0%	0.3%	0.0%	0.0%	0.0%	0.0%	0.0%	0.0%	0.0%	0.0%	0.0%	0.0%	0.0%	0.0%	0.0%	0.2%
<b>Buses</b>	2	28	0	0	30	0	0	0	1	5	0	6	0	0	0	18	5	0	23	0	0	0	0	0	0	59
<b>% Buses</b>	11.1%	7.9%	0.0%	0.0%	8.0%	0.0%	0.0%	0.0%	5.0%	2.2%	0.0%	0.0%	0.0%	0.0%	0.0%	6.8%	13.9%	0.0%	0.0%	0.0%	0.0%	0.0%	0.0%	0.0%	0.0%	4.8%
<b>Pedestrians</b>	0	0	0	0	0	0	0	0	0	0	0	0	0	0	0	1	0	0	0	0	0	0	0	1	2	0
<b>% Pedestrians</b>	0.0%	0.0%	0.0%	0.0%	0.0%	0.0%	0.0%	0.0%	0.0%	0.0%	0.0%	0.0%	0.0%	0.0%	0.0%	0.4%	0.0%	0.0%	0.0%	0.0%	0.0%	0.0%	100.0%	100.0%	100.0%	0.8%
<b>Bicycles on Crosswalk</b>	0	0	0	0	0	0	0	0	0	0	0	0	0	0	0	0	0	0	0	0	0	0	0	0	0	0
<b>% Bicycles on Crosswalk</b>	0.0%	0.0%	0.0%	0.0%	0.0%	0.0%	0.0%	0.0%	0.0%	0.0%	0.0%	0.0%	0.0%	0.0%	0.0%	0.0%	0.0%	0.0%	0.0%	0.0%	0.0%	0.0%	0.0%	0.0%	0.0%	0.0%

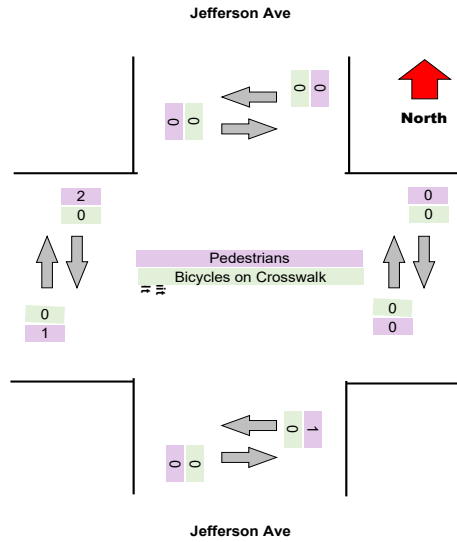
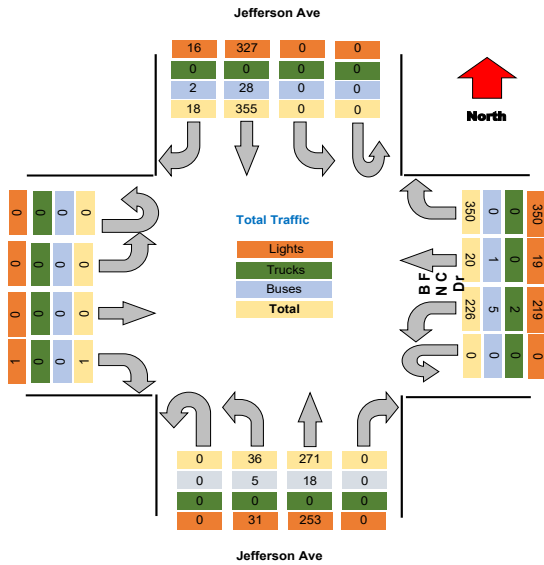



**Turning Movement Peak Hour Data (PM)**

4:15:00 PM

Leg Direction	Jefferson Ave					Fruit Belt					Jefferson Ave					B F N C Dr					Total								
	Southbound					Westbound					Northbound					Eastbound													
Start Time	Right	Thru	Left	U-Turn	App Total	Peds CW	Peds CCW	Right	Thru	Left	U-Turn	App Total	Peds CW	Peds CCW	Right	Thru	Left	U-Turn	App Total	Peds CW	Peds CCW	Right	Thru	Left	U-Turn	App Total	Peds CW	Peds CCW	
4:15:00 PM	6	184	0	0	190	0	0	23	4	60	0	87	0	0	0	72	10	0	82	0	0	0	0	0	0	0	2	1	359
4:30:00 PM	4	192	0	0	196	0	0	27	3	45	0	75	0	0	0	72	11	0	83	0	0	0	0	0	0	1	0	354	
4:45:00 PM	3	146	0	0	149	0	0	16	2	64	0	82	0	0	0	67	8	0	75	0	0	0	0	0	0	0	0	306	
5:00:00 PM	4	154	0	0	158	0	0	22	2	40	0	64	0	0	0	76	10	0	86	0	0	0	0	0	0	0	0	316	
<b>Grand Total</b>	<b>17</b>	<b>685</b>	<b>0</b>	<b>0</b>	<b>703</b>	<b>0</b>	<b>0</b>	<b>88</b>	<b>11</b>	<b>209</b>	<b>0</b>	<b>308</b>	<b>0</b>	<b>0</b>	<b>0</b>	<b>297</b>	<b>39</b>	<b>0</b>	<b>336</b>	<b>0</b>	<b>0</b>	<b>0</b>	<b>0</b>	<b>0</b>	<b>0</b>	<b>3</b>	<b>1</b>	<b>1337</b>	
% Approach	2.4%	97.6%	0.0%	0.0%	0.0%	0.0%	0.0%	28.6%	3.6%	67.9%	0.0%	0.0%	0.0%	0.0%	0.0%	88.0%	12.0%	0.0%	0.0%	0.0%	0.0%	#DIV/0!	#DIV/0!	#DIV/0!	#DIV/0!	0.0%	0.0%	0.0%	
% Total	1.3%	51.3%	0.0%	0.0%	52.6%	0.0%	0.0%	6.6%	0.8%	15.6%	0.0%	23.0%	0.0%	0.0%	0.0%	21.5%	2.9%	0.0%	24.4%	0.0%	0.0%	0.0%	0.0%	0.0%	0.0%	0.0%	0.0%	2.2%	
PHF	0.708	0.893	0.000	0.000	0.897	0.000	0.000	0.815	0.688	0.816	0.000	0.885	0.000	0.000	0.000	0.944	0.886	0.000	0.848	0.000	0.000	0.000	0.000	0.000	0.000	0.000	0.000	0.931	
Lights	17	670	0	0	687	0	0	86	11	207	0	304	0	0	0	278	38	0	316	0	0	0	0	0	0	0	0	1307	
% Lights	100.0%	97.7%	0.0%	0.0%	97.7%	0.0%	0.0%	97.7%	100.0%	99.0%	0.0%	98.7%	0.0%	0.0%	0.0%	96.0%	97.4%	0.0%	96.9%	0.0%	0.0%	0.0%	0.0%	0.0%	0.0%	0.0%	0.0%	97.8%	
Trucks	0	0	0	0	0	0	0	0	0	0	0	0	0	0	0	0	0	0	0	0	0	0	0	0	0	0	0	0	
% Trucks	0.0%	0.0%	0.0%	0.0%	0.0%	0.0%	0.0%	0.0%	0.0%	0.0%	0.0%	0.0%	0.0%	0.0%	0.0%	0.0%	0.0%	0.0%	0.0%	0.0%	0.0%	0.0%	0.0%	0.0%	0.0%	0.0%	0.0%	0.0%	
Buses	0	16	0	0	16	0	0	2	0	2	0	4	0	0	0	9	1	0	10	0	0	0	0	0	0	0	0	30	
% Buses	0.0%	2.3%	0.0%	0.0%	0.0%	0.0%	0.0%	2.3%	0.0%	1.0%	0.0%	0.0%	0.0%	0.0%	0.0%	3.1%	2.6%	0.0%	0.0%	0.0%	0.0%	0.0%	0.0%	0.0%	0.0%	0.0%	0.0%	2.2%	
Pedestrians	0	0	0	0	0	0	0	0	0	0	0	0	1	0	0	0	0	0	0	0	0	0	0	0	0	1	1	0	
% Pedestrians	0.0%	0.0%	0.0%	0.0%	0.0%	0.0%	0.0%	0.0%	0.0%	0.0%	0.0%	0.0%	100.0%	0.0%	0.0%	0.0%	0.0%	0.0%	0.0%	0.0%	0.0%	0.0%	0.0%	0.0%	0.0%	0.0%	33.3%	100.0%	0.0%
Bicycles on Crosswalk	0	0	0	0	0	0	0	0	0	0	0	0	0	0	0	0	0	0	0	0	0	0	0	0	0	0	2	0	
% Bicycles on Crosswalk	0.0%	0.0%	0.0%	0.0%	0.0%	0.0%	0.0%	0.0%	0.0%	0.0%	0.0%	0.0%	0.0%	0.0%	0.0%	0.0%	0.0%	0.0%	0.0%	0.0%	0.0%	0.0%	0.0%	0.0%	0.0%	66.7%	0.0%	0.0%	

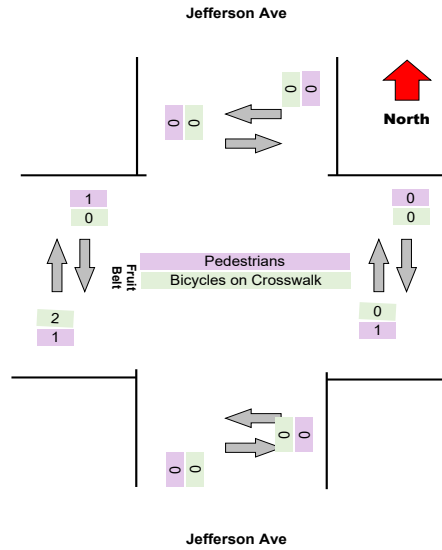
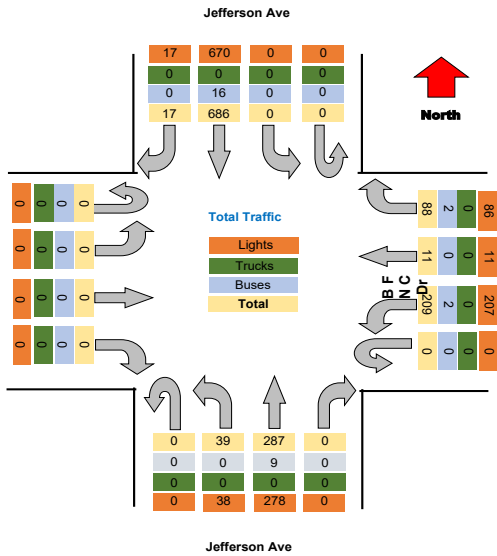

Project : VBH Malta NY  
Site : Site 4  
Location : 42.948550, -73.790036

TSTData.com

Survey Date : 2021-04-28, Wednesday

Project	LaBella
Project Code	LaBella
Site Name	11
Legs and Movements	All Processed Legs & Move
Bin Size	15 minutes
Survey Date	2021-11-04, Thursday
Location	11
Latitude and Longitude	42.897816, -78.853982

	Start	End	PHF
Forced Peak AM	2021/11/04 07:30:00	2021/11/04 08:30:00	0.86
Forced Peak PM	2021/11/04 16:30:00	2021/11/04 17:30:00	0.97
AM Peak	2021/11/04 07:30:00	2021/11/04 08:30:00	0.86
PM Peak	2021/11/04 16:15:00	2021/11/04 17:15:00	0.9

### Turning Movement Data

Leg Direction	Jefferson Ave										Fruit Belt										Jefferson Ave										B F N C Dr										Total
	Southbound					Westbound					Northbound					Eastbound					Eastbound					Eastbound															
Start Time	Right	Thru	Left	U-Turn	App Total	Peds CV	Peds CCV	Right	Thru	Left	U-Turn	App Total	Peds CV	Peds CCV	Right	Thru	Left	U-Turn	App Total	Peds CV	Peds CCV	Right	Thru	Left	U-Turn	App Total	Peds CV	Peds CCV	Total												
6:30:00 AM	0	40	0	0	40	0	0	44	0	17	0	61	0	0	0	29	3	0	32	0	0	0	0	0	0	0	0	0	0	133											
6:45:00 AM	3	32	0	0	35	0	0	73	2	36	0	111	0	0	0	44	3	0	47	0	0	0	0	0	0	0	0	0	0	193											
Hourly Total	3	72	0	0	75	0	0	117	2	53	0	172	0	0	0	73	6	0	79	0	0	0	0	0	0	0	0	0	0	326											
7:00:00 AM	2	52	0	0	54	0	0	45	0	24	0	69	0	0	0	44	4	0	48	0	0	0	0	0	0	0	0	0	0	171											
7:15:00 AM	2	44	0	0	46	0	0	68	2	36	0	106	1	0	0	51	6	0	57	0	0	0	0	0	0	0	0	1	0	210											
7:30:00 AM	5	66	0	0	71	0	0	90	2	59	0	151	0	0	0	61	13	0	74	0	0	0	0	0	0	0	0	0	1	296											
7:45:00 AM	4	93	0	0	97	0	0	110	6	50	0	166	0	0	0	88	19	0	107	0	0	0	0	0	0	0	0	0	0	370											
Hourly Total	13	255	0	0	268	0	0	313	10	169	0	492	1	0	0	244	42	0	287	0	0	0	0	0	0	0	1	1	1047												
8:00:00 AM	2	94	0	0	96	0	0	77	6	43	0	126	1	0	0	84	13	0	97	0	0	0	0	0	0	0	0	0	1	320											
8:15:00 AM	3	92	0	0	95	0	0	65	5	60	0	130	1	0	0	58	8	0	67	0	0	0	0	0	0	0	1	0	292												
Hourly Total	5	186	0	0	191	0	0	142	11	103	0	256	2	0	0	142	21	0	163	0	0	0	0	0	0	0	1	1	612												
4:00:00 PM	5	212	0	0	217	0	0	24	2	63	0	89	0	0	0	52	2	0	54	0	0	0	63	0	0	0	0	2	0	360											
4:15:00 PM	5	174	0	0	179	0	0	24	1	74	0	99	0	0	0	78	6	0	84	0	0	0	0	0	0	0	0	0	0	362											
4:30:00 PM	8	162	0	0	170	0	0	21	4	44	0	69	2	2	0	66	15	0	81	0	0	0	0	0	0	0	0	0	0	320											
4:45:00 PM	4	148	0	0	152	0	0	20	2	57	0	79	0	0	0	66	5	0	71	2	0	0	0	0	0	0	0	2	0	302											
Hourly Total	22	696	0	0	718	0	0	89	9	238	0	336	2	2	0	252	28	0	280	2	0	0	0	0	0	0	2	2	1344												
5:00:00 PM	5	151	0	0	156	0	0	22	3	59	0	84	0	1	0	66	9	0	75	0	0	2	2	0	0	2	2	1	317												
5:15:00 PM	4	136	0	0	140	0	0	17	3	54	0	74	0	1	0	70	13	0	83	0	0	0	0	0	0	0	0	0	0	297											
5:30:00 PM	9	125	0	0	134	0	0	22	0	43	0	65	0	1	0	63	9	0	72	0	0	0	0	0	0	0	0	1	0	271											
5:45:00 PM	4	117	0	0	121	0	0	19	0	51	0	70	1	0	0	61	9	0	70	0	0	0	0	0	0	0	0	0	1	261											
Hourly Total	22	529	0	0	551	0	0	80	6	207	0	293	1	3	0	280	40	0	300	0	0	2	2	0	0	2	3	2	1146												
Grand Total	65	1738	0	0	1803	0	0	741	38	770	0	1549	6	6	0	981	137	0	1121	2	0	2	2	0	0	2	7	6	4475												
% Approach	3.6%	96.4%	0.0%	0.0%	0.0%	0.0%	0.0%	47.8%	2.5%	49.7%	0.0%	0.0%	0.0%	0.0%	0.0%	87.5%	12.2%	0.0%	0.0%	0.0%	0.0%	100.0%	0.0%	0.0%	0.0%	0.0%	0.0%	0.0%	0.0%	0.0%											
% Total	1.5%	38.8%	0.0%	0.0%	40.3%	0.0%	0.0%	16.6%	0.8%	17.2%	0.0%	34.6%	0.0%	0.0%	0.0%	21.9%	3.1%	0.0%	25.1%	0.0%	0.0%	0.0%	0.0%	0.0%	0.0%	0.0%	0.0%	0.0%	0.0%	0.0%											
Lights	62	1678	0	0	1740	0	0	736	35	757	0	1528	0	0	0	932	132	0	1064	0	0	2	2	0	0	2	0	0	4334												
% Lights	95.4%	96.5%	0.0%	0.0%	96.3%	0.0%	0.0%	99.3%	92.1%	98.3%	0.0%	98.6%	0.0%	0.0%	0.0%	95.0%	96.4%	0.0%	94.9%	0.0%	0.0%	100.0%	0.0%	0.0%	0.0%	100.0%	0.0%	0.0%	96.8%												
Trucks	0	0	0	0	0	0	0	1	0	0	0	1	0	0	0	4	0	0	4	0	0	0	0	0	0	0	0	0	5												
% Trucks	0.0%	0.0%	0.0%	0.0%	0.0%	0.0%	0.0%	0.1%	0.0%	0.0%	0.0%	0.1%	0.0%	0.0%	0.0%	0.4%	0.0%	0.0%	0.4%	0.0%	0.0%	0.0%	0.0%	0.0%	0.0%	0.0%	0.0%	0.0%	0.1%												
Buses	3	69	0	0	72	0	0	4	3	13	0	20	0	0	0	44	5	0	49	0	0	0	0	0	0	0	0	0	0	131											
% Buses	4.6%	3.4%	0.0%	0.0%	0.0%	0.0%	0.0%	0.0%	7.9%	1.7%	0.0%	0.0%	0.0%	0.0%	0.0%	4.5%	3.6%	0.0%	0.0%	0.0%	0.0%	0.0%	0.0%	0.0%	0.0%	0.0%	0.0%	0.0%	2.9%												
Pedestrians	0	0	0	0	0	0	0	0	0	0	0	0	6	4	0	0	0	0	0	2	0	0	0	0	0	0	0	6	5	0											
% Pedestrians	0.0%	0.0%	0.0%	0.0%	0.0%	0.0%	0.0%	0.0%	0.0%	0.0%	0.0%	0.0%	100.0%	80.0%	0.0%	0.0%	0.0%	0.0%	0.0%	100.0%	0.0%	0.0%	0.0%	0.0%	0.0%	0.0%	0.0%	85.7%	83.3%	0.0%											
Bicycles on Crosswalk	0	0	0	0	0	0	0	0	0	0	0	0	0	1	0	0	0	0	0	0	0	0	0	0	0	0	0	1	1	0											
% Bicycles on Crosswalk	0.0%	0.0%	0.0%	0.0%	0.0%	0.0%	0.0%	0.0%	0.0%	0.0%	0.0%	0.0%	0.0%	20.0%	0.0%	0.0%	0.0%	0.0%	0.0%	0.0%	0.0%	0.0%	0.0%	0.0%	0.0%	0.0%	0.0%	14.3%	16.7%	0.0%											

### Turning Movement Data Plot

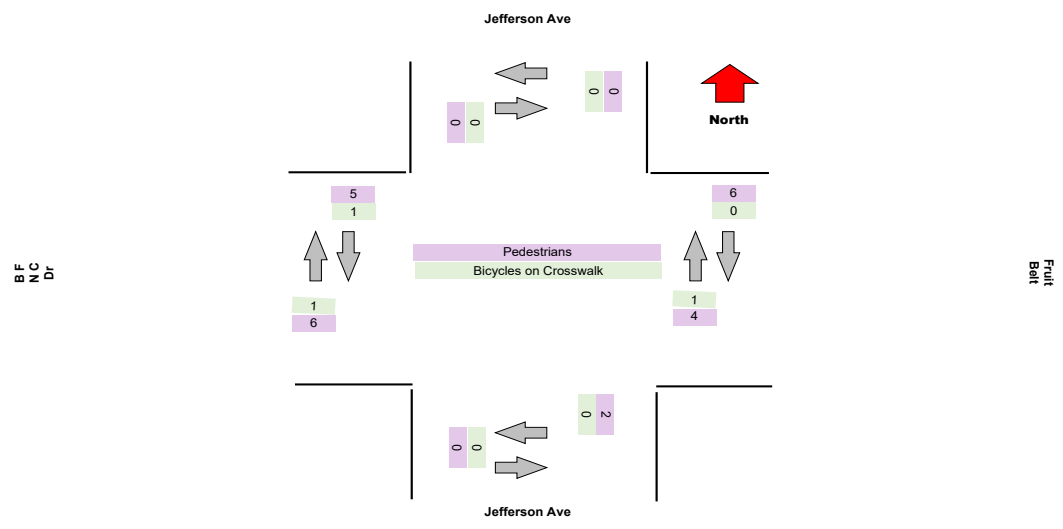
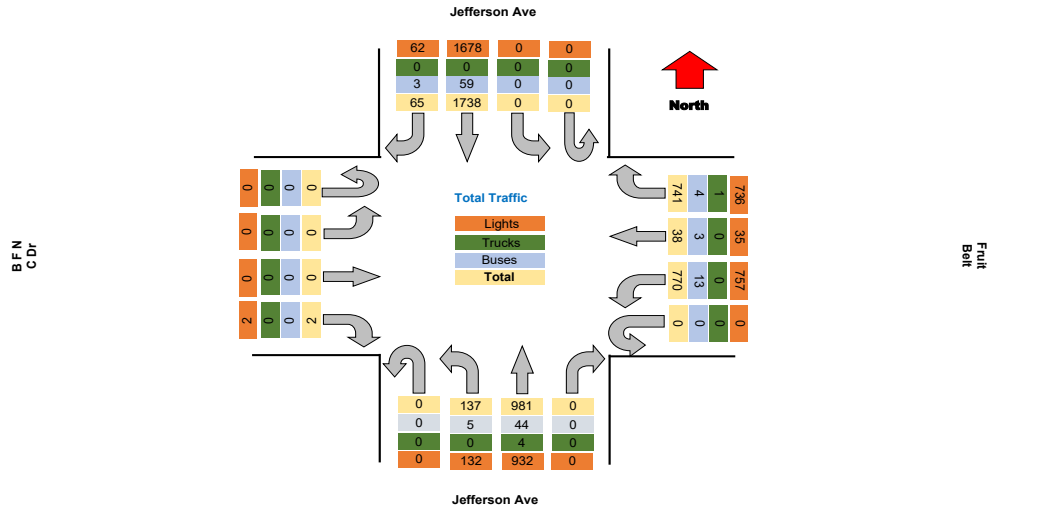

Project : VBH Malta NY  
Site : Site 4  
Location : 42.948550, -73.790036

TSTData.com

Survey Date : 2021-04-28, Wednesday

### Turning Movement Peak Hour Data (AM)

7:30:00 AM

Leg Direction	Jefferson Ave					Fruit Belt					Jefferson Ave					B F N C Dr					Total		
	Southbound		Westbound			Northbound		Eastbound															
Start Time	Right	Thru	Left	U-Turn	App Total	Peds CW	Peds CCW	Right	Thru	Left	U-Turn	App Total	Peds CW	Peds CCW	Right	Thru	Left	U-Turn	App Total	Peds CW	Peds CCW		
7:30:00 AM	5	66	0	0	71	0	0	90	2	59	0	151	0	0	0	61	13	0	74	0	0	1	296
7:45:00 AM	4	93	0	0	97	0	0	110	6	50	0	166	0	0	0	88	19	0	107	0	0	0	370
8:00:00 AM	2	94	0	0	96	0	0	77	6	43	0	126	1	0	0	84	13	0	98	0	0	0	320
8:15:00 AM	3	92	0	0	95	0	0	65	5	60	0	130	1	0	0	58	8	0	67	0	0	0	292
<b>Grand Total</b>	<b>14</b>	<b>345</b>	<b>0</b>	<b>0</b>	<b>359</b>	<b>0</b>	<b>0</b>	<b>342</b>	<b>19</b>	<b>212</b>	<b>0</b>	<b>573</b>	<b>2</b>	<b>0</b>	<b>0</b>	<b>291</b>	<b>53</b>	<b>0</b>	<b>346</b>	<b>0</b>	<b>0</b>	<b>1</b>	<b>1278</b>
% Approach	3.9%	96.1%	0.0%	0.0%	0.0%	0.0%	0.0%	59.7%	3.3%	37.0%	0.0%	0.0%	0.0%	0.0%	0.0%	84.1%	15.3%	0.0%	0.0%	0.0%	0.0%	0.0%	0.0%
% Total	1.1%	27.0%	0.0%	0.0%	28.1%	0.0%	0.0%	26.8%	1.5%	16.6%	0.0%	44.8%	0.0%	0.0%	0.0%	22.8%	4.1%	0.0%	27.1%	0.0%	0.0%	0.0%	0.0%
PHF	0.700	0.918	0.000	0.000	0.925	0.000	0.000	0.777	0.792	0.883	0.000	0.863	0.000	0.000	0.000	0.827	0.697	0.000	0.808	0.000	0.000	0.000	0.864
Lights	12	320	0	0	332	0	0	342	17	207	0	566	0	0	0	272	49	0	321	0	0	0	1219
% Lights	85.7%	92.8%	0.0%	0.0%	92.5%	0.0%	0.0%	100.0%	89.5%	97.6%	0.0%	98.8%	0.0%	0.0%	0.0%	93.5%	92.5%	0.0%	92.8%	0.0%	0.0%	0.0%	95.4%
Trucks	0	0	0	0	0	0	0	0	0	0	0	0	0	0	0	2	0	0	2	0	0	0	2
% Trucks	0.0%	0.0%	0.0%	0.0%	0.0%	0.0%	0.0%	0.0%	0.0%	0.0%	0.0%	0.0%	0.0%	0.0%	0.0%	0.7%	0.0%	0.0%	0.6%	0.0%	0.0%	0.0%	0.2%
Buses	2	25	0	0	27	0	0	0	2	5	0	7	0	0	0	17	4	0	21	0	0	0	55
% Buses	14.3%	7.2%	0.0%	0.0%	0.0%	0.0%	0.0%	0.0%	10.5%	2.4%	0.0%	0.0%	0.0%	0.0%	0.0%	5.8%	7.5%	0.0%	0.0%	0.0%	0.0%	0.0%	4.3%
Pedestrians	0	0	0	0	0	0	0	0	0	0	0	0	2	0	0	0	0	0	0	0	0	1	2
% Pedestrians	0.0%	0.0%	0.0%	0.0%	0.0%	0.0%	0.0%	0.0%	0.0%	0.0%	0.0%	0.0%	100.0%	0.0%	0.0%	0.0%	0.0%	0.0%	0.0%	0.0%	0.0%	0.0%	100.0%
Bicycles on Crosswalk	0	0	0	0	0	0	0	0	0	0	0	0	0	0	0	0	0	0	0	0	0	0	0
% Bicycles on Crosswalk	0.0%	0.0%	0.0%	0.0%	0.0%	0.0%	0.0%	0.0%	0.0%	0.0%	0.0%	0.0%	0.0%	0.0%	0.0%	0.0%	0.0%	0.0%	0.0%	0.0%	0.0%	0.0%	0.0%

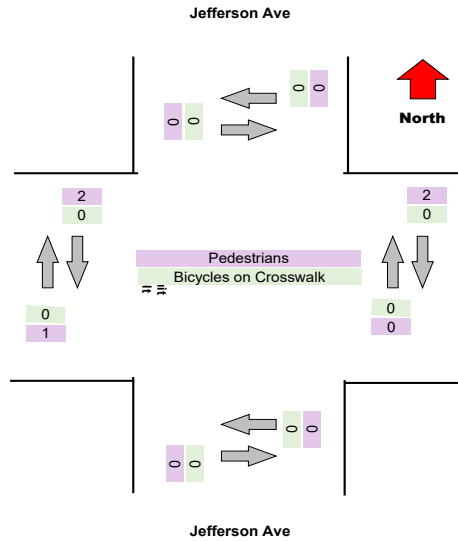
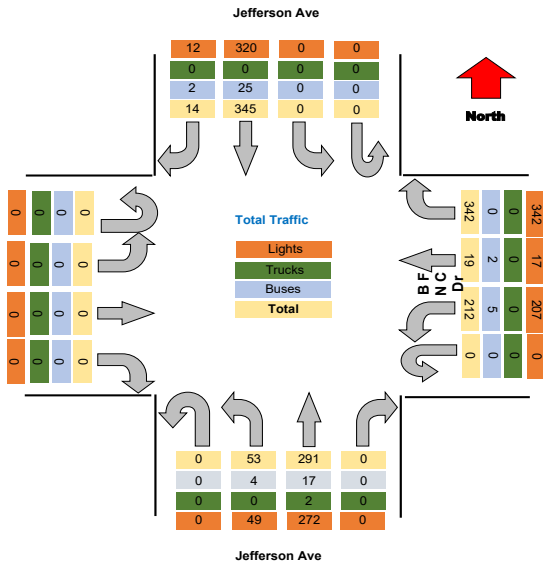

**Turning Movement Peak Hour Data (PM)**

4:15:00 PM

Leg Direction	Jefferson Ave						Fruit Belt						Jefferson Ave						B F N C Dr						Total					
	Southbound			Northbound			Westbound			Eastbound			Northbound			Eastbound														
Start Time	Right	Thru	Left	U-Turn	App Total	Peds CW	Peds CCW	Right	Thru	Left	U-Turn	App Total	Peds CW	Peds CCW	Right	Thru	Left	U-Turn	App Total	Peds CW	Peds CCW	Right	Thru	Left	U-Turn	App Total	Peds CW	Peds CCW		
4:15:00 PM	5	174	0	0	179	0	0	24	1	74	0	99	0	0	0	78	6	0	84	0	0	0	0	0	0	0	0	0	0	
4:30:00 PM	8	162	0	0	170	0	0	21	4	44	0	69	2	2	0	66	15	0	81	0	0	0	0	0	0	0	0	0		
4:45:00 PM	4	148	0	0	152	0	0	20	2	57	0	79	0	0	0	66	5	0	71	2	0	0	0	0	0	0	2	2		
5:00:00 PM	5	151	0	0	156	0	0	22	3	59	0	84	0	0	0	66	9	0	75	0	0	2	0	0	2	2	1	317		
<b>Grand Total</b>	<b>22</b>	<b>635</b>	<b>0</b>	<b>0</b>	<b>657</b>	<b>0</b>	<b>0</b>	<b>87</b>	<b>10</b>	<b>234</b>	<b>0</b>	<b>331</b>	<b>2</b>	<b>2</b>	<b>0</b>	<b>276</b>	<b>35</b>	<b>0</b>	<b>311</b>	<b>2</b>	<b>0</b>	<b>2</b>	<b>0</b>	<b>0</b>	<b>2</b>	<b>2</b>	<b>3</b>	<b>1381</b>		
% Approach	3.3%	96.7%	0.0%	0.0%	0.0%	0.0%	0.0%	28.3%	3.0%	70.7%	0.0%	0.0%	0.0%	0.0%	0.0%	88.7%	11.3%	0.0%	0.0%	0.0%	0.0%	100.0%	0.0%	0.0%	0.0%	0.0%	0.0%	0.0%	0.0%	
% Total	1.7%	48.8%	0.0%	0.0%	50.5%	0.0%	0.0%	6.7%	0.8%	18.0%	0.0%	25.4%	0.0%	0.0%	0.0%	21.2%	2.7%	0.0%	23.9%	0.0%	0.0%	0.2%	0.0%	0.0%	0.0%	0.2%	0.0%	0.0%		
PHF	0.688	0.912	0.000	0.000	0.918	0.000	0.000	0.906	0.625	0.791	0.000	0.836	0.000	0.000	0.000	0.885	0.583	0.000	0.826	0.000	0.000	0.250	0.000	0.000	0.000	0.250	0.000	0.000	0.898	
Lights	22	620	0	0	642	0	0	85	10	229	0	324	0	0	0	264	35	0	299	0	0	2	0	0	0	2	2	3		
% Lights	100.0%	97.6%	0.0%	0.0%	97.7%	0.0%	0.0%	97.7%	100.0%	97.9%	0.0%	97.9%	0.0%	0.0%	0.0%	95.7%	100.0%	0.0%	96.1%	0.0%	0.0%	100.0%	0.0%	0.0%	100.0%	0.0%	0.0%	0.0%	97.4%	
Trucks	0	0	0	0	0	0	0	0	0	0	0	0	0	0	1	0	0	0	1	0	0	0	0	0	0	0	0	0	1	
% Trucks	0.0%	0.0%	0.0%	0.0%	0.0%	0.0%	0.0%	0.0%	0.0%	0.0%	0.0%	0.0%	0.0%	0.0%	0.4%	0.0%	0.0%	0.3%	0.0%	0.0%	0.0%	0.0%	0.0%	0.0%	0.0%	0.0%	0.0%	0.1%		
Buses	0	15	0	0	15	0	0	2	0	5	0	7	0	0	0	10	0	0	10	0	0	0	0	0	0	0	0	0	32	
% Buses	0.0%	2.4%	0.0%	0.0%	2.3%	0.0%	0.0%	2.3%	0.0%	2.1%	0.0%	2.1%	0.0%	0.0%	0.0%	3.6%	0.0%	0.0%	3.2%	0.0%	0.0%	0.0%	0.0%	0.0%	0.0%	0.0%	0.0%	0.0%	2.5%	
Pedestrians	0	0	0	0	0	0	0	0	0	0	0	2	3	0	0	0	0	0	2	0	0	0	0	0	0	0	2	3	0	
% Pedestrians	0.0%	0.0%	0.0%	0.0%	0.0%	0.0%	0.0%	0.0%	0.0%	0.0%	0.0%	0.6%	0.9%	100.0%	0.0%	0.0%	0.0%	0.6%	0.6%	100.0%	0.0%	0.0%	0.0%	0.0%	0.0%	0.0%	0.0%	100.0%	100.0%	0.0%
Bicycles on Crosswalk	0	0	0	0	0	0	0	0	0	0	0	0	0	0	0	0	0	0	0	0	0	0	0	0	0	0	0	0	0	
% Bicycles on Crosswalk	0.0%	0.0%	0.0%	0.0%	0.0%	0.0%	0.0%	0.0%	0.0%	0.0%	0.0%	0.0%	0.0%	0.0%	0.0%	0.0%	0.0%	0.0%	0.0%	0.0%	0.0%	0.0%	0.0%	0.0%	0.0%	0.0%	0.0%	0.0%	0.0%	

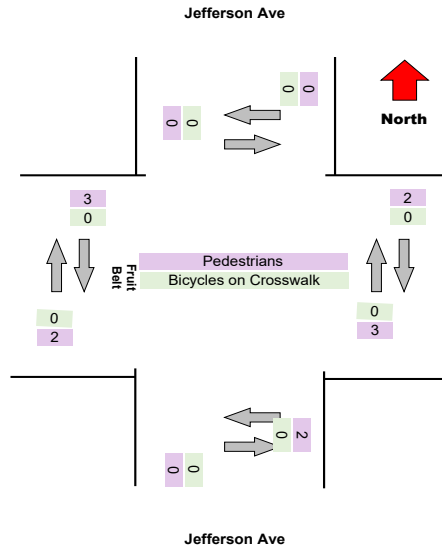
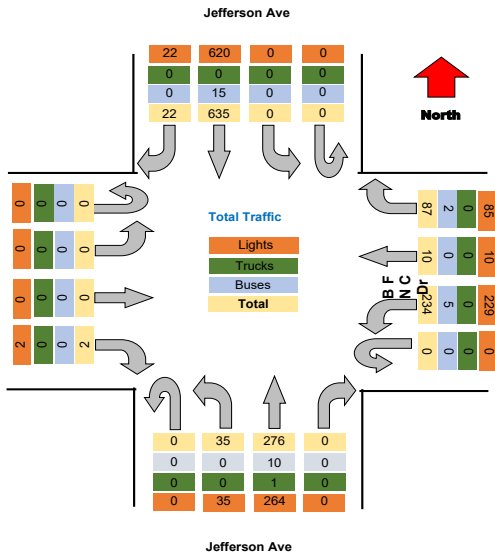



Project : VBH Malta NY  
 Site : Site 4  
 Location : 42.948550, -73.790036  
 Survey Date : 2021-04-28, Wednesday

### Turning Movement Data Plot

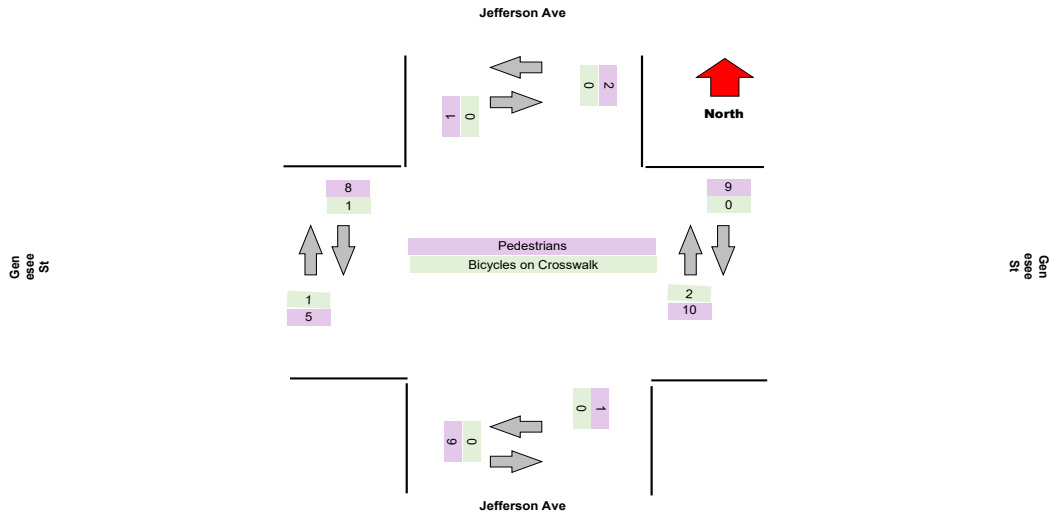
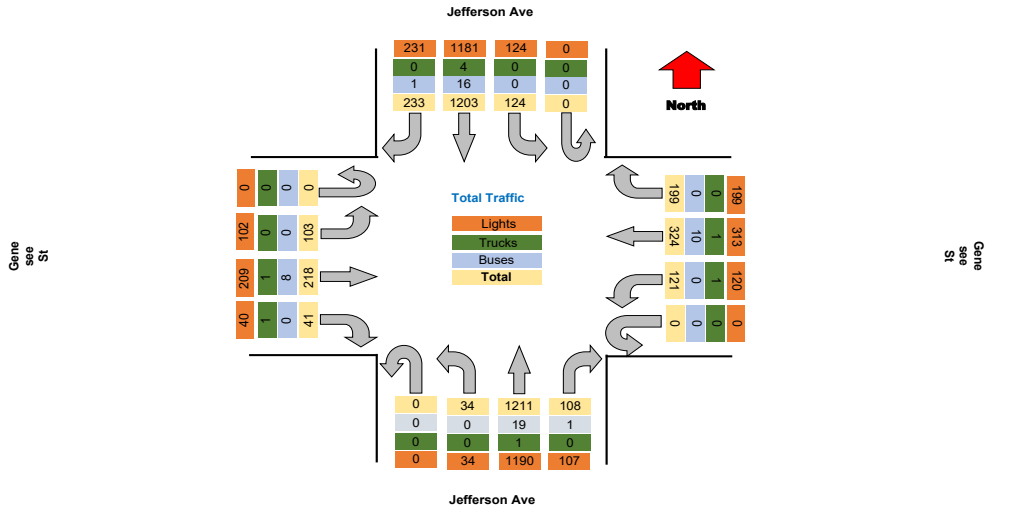

Project : VBH Malta NY  
Site : Site 4  
Location : 42.948550, -73.790036  
Survey Date : 2021-04-28, Wednesday

TSTData.com

**Turning Movement Peak Hour Data (AM)**

7:30:00 AM

Leg Direction	Jefferson Ave					Genesee St					Jefferson Ave					Genesee St					Total								
	Southbound		Northbound			Westbound		Eastbound			Northbound		Eastbound			Northbound		Eastbound											
Start Time	Right	Thru	Left	U-Turn	App Total	Peds CW	Peds CCW	Right	Thru	Left	U-Turn	App Total	Peds CW	Peds CCW	Right	Thru	Left	U-Turn	App Total	Peds CW	Peds CCW	Right	Thru	Left	U-Turn	App Total	Peds CW	Peds CCW	
7:30:00 AM	6	44	4	0	54	0	0	13	19	1	0	33	0	0	4	79	1	0	84	0	2	1	4	1	0	6	2	0	177
7:45:00 AM	6	65	7	0	78	0	0	14	20	10	0	44	0	0	2	59	2	0	63	0	2	2	11	4	0	17	0	0	202
8:00:00 AM	11	67	3	0	81	0	0	11	22	9	0	42	0	0	0	68	4	0	72	0	0	0	12	3	0	15	0	1	210
8:15:00 AM	7	68	8	0	83	0	0	15	26	5	0	46	1	1	6	49	2	0	59	0	2	0	13	0	0	13	0	0	201
<b>Grand Total</b>	<b>30</b>	<b>244</b>	<b>22</b>	<b>0</b>	<b>296</b>	<b>0</b>	<b>0</b>	<b>53</b>	<b>87</b>	<b>25</b>	<b>0</b>	<b>155</b>	<b>1</b>	<b>1</b>	<b>12</b>	<b>255</b>	<b>9</b>	<b>0</b>	<b>273</b>	<b>0</b>	<b>6</b>	<b>3</b>	<b>40</b>	<b>8</b>	<b>0</b>	<b>51</b>	<b>2</b>	<b>1</b>	<b>790</b>
<b>% Approach</b>	10.1%	82.4%	7.4%	0.0%	<b>0.0%</b>	0.0%	0.0%	32.1%	52.7%	15.2%	0.0%	<b>0.0%</b>	0.0%	0.0%	4.3%	91.7%	3.2%	0.0%	<b>0.0%</b>	0.0%	0.0%	5.9%	75.4%	15.7%	0.0%	<b>0.0%</b>	0.0%	0.0%	17.7%
<b>% Total</b>	3.8%	30.9%	2.8%	0.0%	<b>37.5%</b>	0.0%	0.0%	6.7%	11.0%	3.2%	0.0%	<b>20.9%</b>	0.0%	0.0%	1.5%	32.3%	1.1%	0.0%	<b>35.2%</b>	0.0%	0.0%	0.4%	5.1%	1.0%	0.0%	<b>6.5%</b>	0.0%	0.0%	1.8%
<b>PHF</b>	0.682	0.897	0.688	0.000	<b>0.892</b>	0.000	0.000	0.883	0.837	0.625	0.000	<b>0.897</b>	0.000	0.000	0.500	0.807	0.563	0.000	<b>0.827</b>	0.000	0.000	0.375	0.769	0.500	0.000	<b>0.750</b>	0.000	0.000	0.940
<b>Lights</b>	29	238	22	0	<b>289</b>	0	0	53	85	24	0	<b>162</b>	0	0	12	252	9	0	<b>273</b>	0	0	3	37	8	0	<b>48</b>	0	0	<b>772</b>
<b>% Lights</b>	96.7%	97.5%	100.0%	0.0%	<b>97.6%</b>	0.0%	0.0%	100.0%	97.7%	96.0%	0.0%	<b>98.2%</b>	0.0%	0.0%	100.0%	98.8%	100.0%	0.0%	<b>98.2%</b>	0.0%	0.0%	100.0%	92.5%	100.0%	0.0%	<b>94.1%</b>	0.0%	0.0%	<b>97.7%</b>
<b>Trucks</b>	0	0	0	0	<b>0</b>	0	0	0	0	1	0	<b>1</b>	0	0	0	0	0	0	<b>0</b>	0	0	0	1	0	0	<b>1</b>	0	0	<b>2</b>
<b>% Trucks</b>	0.0%	0.0%	0.0%	0.0%	<b>0.0%</b>	0.0%	0.0%	0.0%	0.0%	4.0%	0.0%	<b>0.6%</b>	0.0%	0.0%	0.0%	0.0%	0.0%	0.0%	<b>0.0%</b>	0.0%	0.0%	0.0%	2.5%	0.0%	0.0%	<b>2.0%</b>	0.0%	0.0%	<b>0.3%</b>
<b>Buses</b>	0	5	0	0	<b>5</b>	0	0	0	2	0	0	<b>2</b>	0	0	0	3	0	0	<b>3</b>	0	0	0	2	0	0	<b>2</b>	0	0	<b>12</b>
<b>% Buses</b>	0.0%	2.0%	0.0%	0.0%	<b>0.0%</b>	0.0%	0.0%	0.0%	2.3%	0.0%	0.0%	<b>0.0%</b>	0.0%	0.0%	0.0%	1.2%	0.0%	0.0%	<b>0.0%</b>	0.0%	0.0%	0.0%	5.0%	0.0%	0.0%	<b>0.0%</b>	0.0%	0.0%	<b>1.5%</b>
<b>Pedestrians</b>	0	0	0	0	<b>0</b>	0	0	0	0	0	0	<b>0</b>	1	1	0	0	0	0	<b>0</b>	0	6	0	0	0	0	<b>0</b>	2	1	<b>0</b>
<b>% Pedestrians</b>	0.0%	0.0%	0.0%	0.0%	<b>0.0%</b>	0.0%	0.0%	0.0%	0.0%	0.0%	0.0%	<b>0.0%</b>	100.0%	100.0%	0.0%	0.0%	0.0%	0.0%	<b>0.0%</b>	0.0%	100.0%	0.0%	0.0%	0.0%	0.0%	<b>0.0%</b>	100.0%	100.0%	<b>0.0%</b>
<b>Bicycles on Crosswalk</b>	0	0	0	0	<b>0</b>	0	0	0	0	0	0	<b>0</b>	0	0	0	0	0	0	<b>0</b>	0	0	0	0	0	0	<b>0</b>	0	0	<b>0</b>
<b>% Bicycles on Crosswalk</b>	0.0%	0.0%	0.0%	0.0%	<b>0.0%</b>	0.0%	0.0%	0.0%	0.0%	0.0%	0.0%	<b>0.0%</b>	0.0%	0.0%	0.0%	0.0%	0.0%	0.0%	<b>0.0%</b>	0.0%	0.0%	0.0%	0.0%	0.0%	0.0%	<b>0.0%</b>	0.0%	0.0%	<b>0.0%</b>

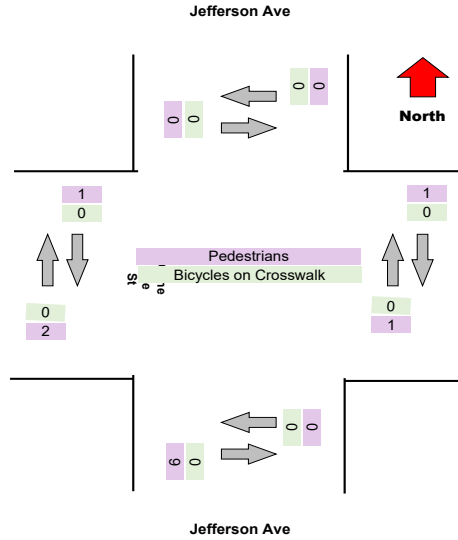
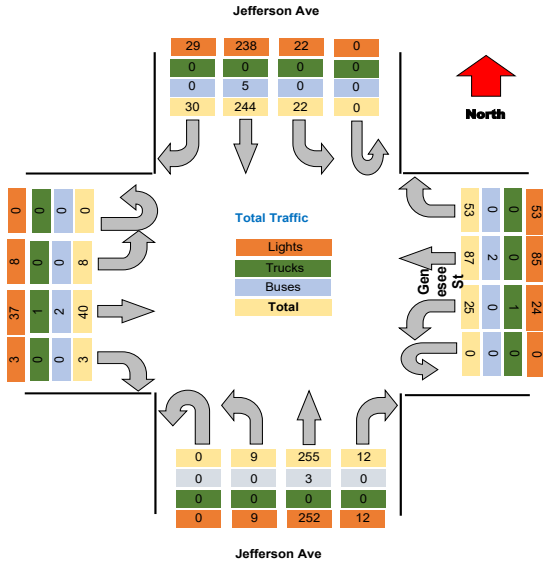



Project : VBH Malta NY  
Site : Site 4  
Location : 42.948550, -73.790036

TSTData.com

Survey Date : 2021-04-28, Wednesday

### Turning Movement Peak Hour Data (PM)

4:15:00 PM

Leg Direction	Jefferson Ave								Genesee St								Jefferson Ave								Genesee St								Total
	Southbound				Northbound				Westbound				Eastbound				Northbound				Eastbound												
	Right	Thru	Left	U-Turn	App Total	Peds CW	Peds CCW		Right	Thru	Left	U-Turn	App Total	Peds CW	Peds CCW		Right	Thru	Left	U-Turn	App Total	Peds CW	Peds CCW		Right	Thru	Left	U-Turn	App Total	Peds CW	Peds CCW		
4:15:00 PM	19	111	11	0	141	0	0	17	20	14	0	51	1	1	4	88	6	0	98	0	0	6	17	13	0	36	0	0	326				
4:30:00 PM	14	119	7	0	140	0	0	14	26	9	0	49	0	4	7	91	1	0	99	0	0	4	19	9	0	32	0	0	326				
4:45:00 PM	21	114	7	0	142	0	0	15	16	10	0	41	2	1	17	96	2	0	115	1	0	5	16	7	0	28	2	0	343				
5:00:00 PM	18	84	16	0	118	0	0	13	19	8	0	41	0	0	12	117	2	0	131	0	0	6	31	16	0	53	1	1	1315				
<b>Grand Total</b>	<b>72</b>	<b>428</b>	<b>41</b>	<b>0</b>	<b>541</b>	<b>0</b>	<b>0</b>	<b>59</b>	<b>81</b>	<b>42</b>	<b>0</b>	<b>182</b>	<b>3</b>	<b>6</b>	<b>40</b>	<b>392</b>	<b>11</b>	<b>0</b>	<b>443</b>	<b>1</b>	<b>0</b>	<b>21</b>	<b>83</b>	<b>45</b>	<b>0</b>	<b>149</b>	<b>3</b>	<b>1</b>	<b>1315</b>				
% Approach	13.3%	79.1%	7.6%	0.0%	0.0%	0.0%	0.0%	32.4%	44.5%	23.1%	0.0%	0.0%	0.0%	0.0%	9.0%	98.5%	2.5%	0.0%	0.0%	0.0%	0.0%	14.1%	55.7%	30.2%	0.0%	0.0%	0.0%	0.0%	0.0%				
% Total	5.5%	32.5%	3.1%	0.0%	41.1%	0.0%	0.0%	4.5%	6.2%	3.2%	0.0%	13.8%	0.0%	0.0%	3.0%	29.8%	0.8%	0.0%	33.7%	0.0%	0.0%	1.6%	6.3%	3.4%	0.0%	11.3%	0.0%	0.0%					
PHF	0.857	0.899	0.641	0.000	0.952	0.000	0.000	0.868	0.779	0.750	0.000	0.892	0.000	0.000	0.588	0.838	0.458	0.000	0.845	0.000	0.000	0.875	0.669	0.703	0.000	0.703	0.000	0.000	0.958				
Lights	72	422	41	0	535	0	0	59	78	42	0	179	0	0	40	386	11	0	437	0	0	21	81	44	0	146	0	0	1297				
% Lights	100.0%	98.6%	100.0%	0.0%	98.9%	0.0%	0.0%	100.0%	96.3%	100.0%	0.0%	98.4%	0.0%	0.0%	100.0%	98.5%	100.0%	0.0%	98.6%	0.0%	0.0%	100.0%	97.6%	97.8%	0.0%	98.0%	0.0%	0.0%	98.6%				
Trucks	0	1	0	0	1	0	0	0	0	0	0	0	0	0	0	0	0	0	0	0	0	0	0	0	0	0	0	0	0	1			
% Trucks	0.0%	0.2%	0.0%	0.0%	0.2%	0.0%	0.0%	0.0%	0.0%	0.0%	0.0%	0.0%	0.0%	0.0%	0.0%	0.0%	0.0%	0.0%	0.0%	0.0%	0.0%	0.0%	0.0%	0.0%	0.0%	0.0%	0.0%	0.0%	0.1%				
Buses	0	4	0	0	4	0	0	0	3	0	0	3	0	0	0	5	0	0	5	0	0	0	2	0	0	0	2	0	0	14			
% Buses	0.0%	0.9%	0.0%	0.0%	0.0%	0.0%	0.0%	0.0%	3.7%	0.0%	0.0%	0.0%	0.0%	0.0%	0.0%	1.3%	0.0%	0.0%	0.0%	0.0%	0.0%	0.0%	2.4%	0.0%	0.0%	0.0%	0.0%	0.0%	1.1%				
Pedestrians	0	0	0	0	0	0	0	0	0	0	0	3	6	0	0	0	0	0	1	0	0	0	0	0	0	0	0	2	1	0			
% Pedestrians	0.0%	0.0%	0.0%	0.0%	0.0%	0.0%	0.0%	0.0%	0.0%	0.0%	0.0%	0.0%	100.0%	100.0%	0.0%	0.0%	0.0%	0.0%	0.0%	0.0%	0.0%	0.0%	0.0%	0.0%	0.0%	0.0%	0.0%	60.7%	100.0%	0.0%			
Bicycles on Crosswalk	0	0	0	0	0	0	0	0	0	0	0	0	0	0	0	0	0	0	0	0	0	0	0	0	0	0	0	1	0	0			
% Bicycles on Crosswalk	0.0%	0.0%	0.0%	0.0%	0.0%	0.0%	0.0%	0.0%	0.0%	0.0%	0.0%	0.0%	0.0%	0.0%	0.0%	0.0%	0.0%	0.0%	0.0%	0.0%	0.0%	0.0%	0.0%	0.0%	0.0%	0.0%	0.0%	33.3%	0.0%	0.0%			

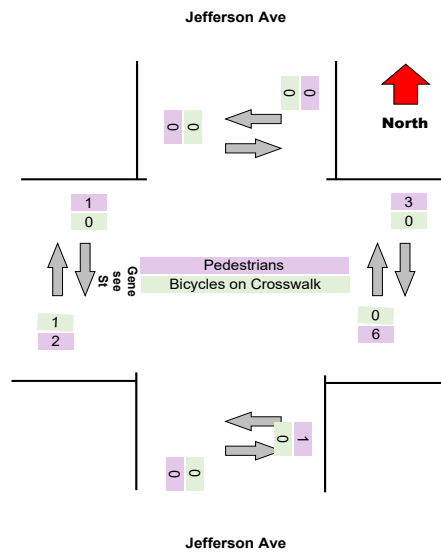
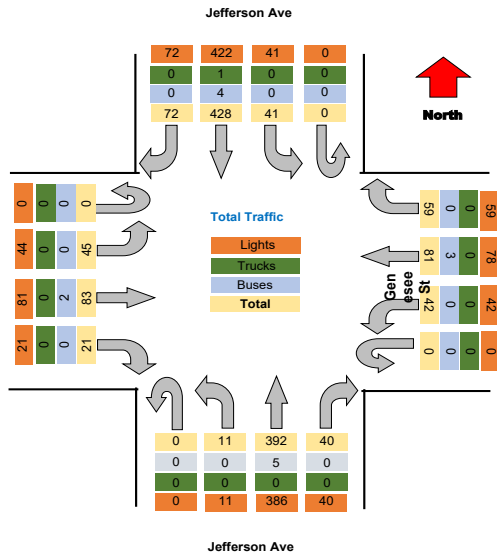

Project : VBH Malta NY  
 Site : Site 4  
 Location : 42.948550, -73.790036

TSTData.com

Survey Date : 2021-04-28, Wednesday

Project	LaBella
Project Code	LaBella
Site Name	12
Legs and Movements	All Processed Legs & Move
Bin Size	15 minutes
Survey Date	2021-11-03, Wednesday
Location	12
Latitude and Longitude	42.896155, -78.853968

	Start	End	PHF
Forced Peak AM	2021/11/03 07:30:00	2021/11/03 08:30:00	0.89
Forced Peak PM	2021/11/03 16:30:00	2021/11/03 17:30:00	0.94
AM Peak	2021/11/03 07:30:00	2021/11/03 08:30:00	0.89
PM Peak	2021/11/03 16:15:00	2021/11/03 17:15:00	0.93

### Turning Movement Data

Leg Direction	Jefferson Ave					Genesee St					Jefferson Ave					Genesee St					Total									
	Southbound					Westbound					Northbound					Eastbound														
Start Time	Right	Thru	Left	U-Turn	App Total	Peds CW	Peds CCW	Right	Thru	Left	U-Turn	App Total	Peds CW	Peds CCW	Right	Thru	Left	U-Turn	App Total	Peds CW	Peds CCW	Right	Thru	Left	U-Turn	App Total	Peds CW	Peds CCW	Total	
6:30:00 AM	5	33	0	0	38	0	0	3	10	2	0	15	0	0	3	39	1	0	43	0	0	1	5	4	0	10	0	1	106	
6:45:00 AM	4	46	3	0	53	0	0	16	14	6	0	36	0	0	5	50	0	0	55	0	0	0	4	5	0	9	0	1	153	
Hourly Total	9	79	3	0	91	0	0	19	24	8	0	51	0	0	8	89	1	0	98	0	0	1	9	9	0	19	0	2	259	
7:00:00 AM	7	45	4	0	56	1	0	12	17	11	0	39	2	0	3	58	0	0	63	0	0	3	6	2	0	11	0	0	160	
7:15:00 AM	11	60	5	0	76	0	0	11	13	3	0	27	1	0	4	77	1	0	83	2	0	4	6	5	0	15	1	1	201	
7:30:00 AM	11	75	7	0	93	0	0	18	28	4	0	50	0	0	3	94	3	0	100	0	2	0	10	8	0	18	0	1	261	
7:45:00 AM	12	96	6	0	114	0	0	22	45	11	0	78	0	1	7	117	0	0	125	0	0	2	16	10	0	28	0	0	345	
Hourly Total	41	276	22	0	339	1	0	63	103	19	0	185	3	1	17	346	4	0	371	2	2	9	38	25	0	72	1	2	967	
8:00:00 AM	21	111	3	0	135	0	1	16	40	8	0	65	0	0	8	84	4	0	96	0	0	4	28	8	0	40	0	0	336	
8:15:00 AM	16	94	9	0	119	0	0	10	37	10	0	57	0	0	4	83	0	0	87	0	0	3	19	5	0	27	0	0	290	
Hourly Total	37	205	12	0	254	0	1	26	77	18	0	122	0	0	12	167	4	0	183	0	0	7	47	13	0	67	0	0	626	
4:00:00 PM	26	122	8	0	156	0	0	14	34	8	0	56	0	0	13	123	1	0	137	1	0	2	45	15	0	62	0	1	411	
4:15:00 PM	23	125	14	0	162	0	0	16	40	8	0	64	0	0	6	135	3	0	144	2	0	11	26	11	0	48	3	4	418	
4:30:00 PM	24	124	12	0	160	1	0	24	29	16	0	71	0	0	8	109	1	0	118	0	0	8	29	8	0	45	0	0	394	
4:45:00 PM	26	103	9	0	139	0	0	17	24	11	0	52	0	0	15	108	3	0	126	1	0	3	30	8	0	41	1	0	357	
Hourly Total	99	474	43	0	616	1	0	71	127	45	0	243	0	0	42	475	8	0	525	4	0	24	130	42	0	196	4	5	1580	
5:00:00 PM	30	110	9	0	149	0	0	11	25	9	0	45	1	0	13	133	3	0	149	0	0	6	25	9	0	40	1	0	383	
5:15:00 PM	30	108	11	0	149	0	0	9	33	7	0	49	2	0	6	100	2	0	108	3	1	5	26	15	0	46	2	1	352	
5:30:00 PM	29	90	12	0	131	0	0	12	22	9	0	43	0	1	10	114	5	0	129	1	0	5	18	10	0	33	1	0	336	
5:45:00 PM	24	88	11	0	123	0	0	9	24	12	0	45	1	0	8	87	4	0	99	1	0	5	19	8	0	32	0	0	299	
Hourly Total	113	396	43	0	552	0	0	41	104	37	0	182	4	1	37	434	14	0	485	5	1	21	88	42	0	151	4	1	1370	
Grand Total	299	1430	123	0	1852	2	1	220	435	127	0	783	7	2	116	1511	31	0	1662	11	3	62	312	131	0	505	9	10	4502	
% Approach	16.1%	77.2%	6.6%	0.0%	0.0%	0.0%	0.0%	28.1%	55.6%	16.2%	0.0%	0.0%	0.0%	0.0%	7.0%	90.9%	1.9%	0.0%	0.0%	0.0%	0.0%	12.3%	61.8%	25.9%	0.0%	0.0%	0.0%	0.0%	0.0%	
% Total	6.2%	29.8%	2.6%	0.0%	38.6%	0.0%	0.0%	4.6%	8.1%	2.6%	0.0%	16.3%	0.0%	0.0%	2.4%	31.5%	0.6%	0.0%	34.6%	0.0%	0.0%	1.3%	6.5%	2.7%	0.0%	10.5%	0.0%	0.0%	0.0%	
Lights	298	1363	116	0	1777	0	0	212	417	117	0	746	0	0	113	1458	30	0	1601	0	0	57	294	127	0	478	0	0	4602	
% Lights	99.7%	95.3%	94.3%	0.0%	96.0%	0.0%	0.0%	95.4%	95.9%	92.1%	0.0%	95.3%	0.0%	0.0%	97.4%	96.5%	96.8%	0.0%	96.3%	0.0%	0.0%	91.9%	94.2%	96.9%	0.0%	94.7%	0.0%	0.0%	95.8%	
Trucks	0	3	0	0	3	0	0	0	2	1	0	3	0	0	0	3	1	0	4	0	0	0	0	0	0	0	0	0	0	10
% Trucks	0.0%	0.2%	0.0%	0.0%	0.2%	0.0%	0.0%	0.0%	0.5%	0.8%	0.0%	0.4%	0.0%	0.0%	0.0%	0.2%	3.2%	0.0%	0.2%	0.0%	0.0%	0.0%	0.0%	0.0%	0.0%	0.0%	0.0%	0.0%	0.2%	
Buses	1	64	7	0	72	0	0	8	15	7	0	30	0	0	3	50	0	0	53	0	0	5	18	3	0	26	0	0	181	
% Buses	0.3%	4.5%	5.7%	0.0%	0.0%	0.0%	0.0%	0.0%	3.4%	5.5%	0.0%	0.0%	0.0%	0.0%	2.6%	3.3%	0.0%	0.0%	0.0%	0.0%	0.0%	8.1%	5.8%	2.3%	0.0%	0.0%	0.0%	0.0%	3.9%	
Pedestrians	0	0	0	0	0	2	0	0	0	0	0	0	7	2	0	0	0	0	0	0	10	3	0	0	0	0	7	10	0	
% Pedestrians	0.0%	0.0%	0.0%	0.0%	0.0%	100.0%	0.0%	0.0%	0.0%	0.0%	0.0%	0.0%	100.0%	100.0%	0.0%	0.0%	0.0%	0.0%	0.0%	0.0%	90.8%	100.0%	0.0%	0.0%	0.0%	0.0%	0.0%	77.3%	100.0%	0.0%
Bicycles on Crosswalk	0	0	0	0	0	0	1	0	0	0	0	0	0	0	0	0	0	0	0	1	0	0	0	0	0	0	2	0	0	
% Bicycles on Crosswalk	0.0%	0.0%	0.0%	0.0%	0.0%	0.0%	100.0%	0.0%	0.0%	0.0%	0.0%	0.0%	0.0%	0.0%	0.0%	0.0%	0.0%	0.0%	0.0%	0.0%	9.1%	0.0%	0.0%	0.0%	0.0%	0.0%	0.0%	0.0%	23.3%	0.0%

Project : VBH Malta NY  
 Site : Site 4  
 Location : 42.948550, -73.790036  
 Survey Date : 2021-04-28, Wednesday

### Turning Movement Data Plot

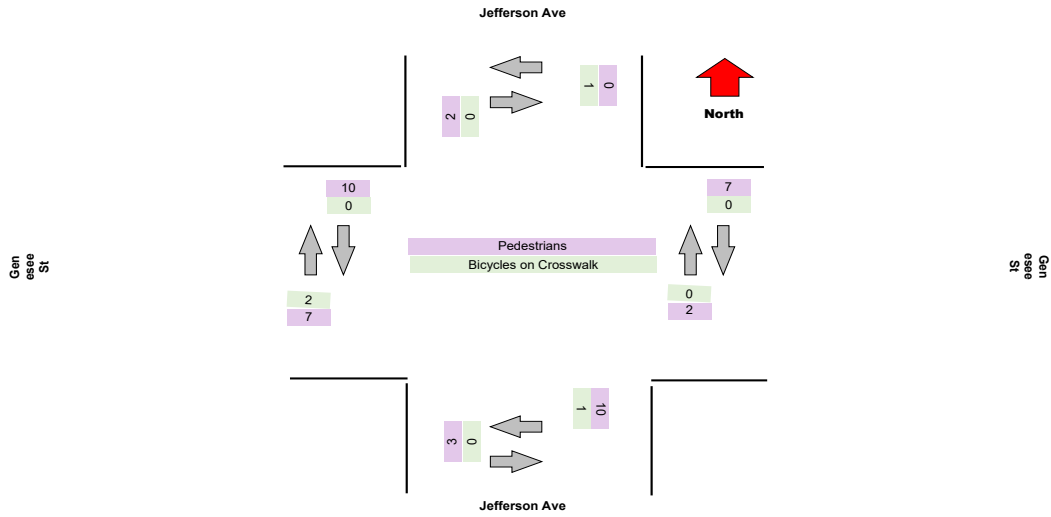
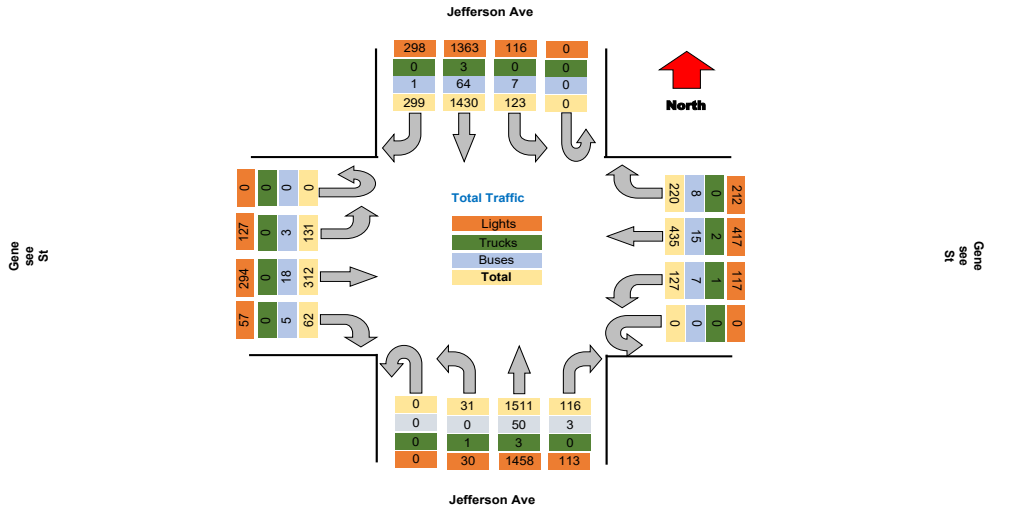

**Turning Movement Peak Hour Data (AM)**

7:30:00 AM

Leg Direction	Jefferson Ave					Genesee St					Jefferson Ave					Genesee St					Total								
	Right	Thru	Left	U-Turn	App Total	Peds CW	Peds CCW	Right	Thru	Left	U-Turn	App Total	Peds CW	Peds CCW	Right	Thru	Left	U-Turn	App Total	Peds CW		Peds CCW							
7:30:00 AM	11	75	7	0	93	0	0	18	28	4	0	50	0	0	3	94	3	0	100	0	2	0	10	8	0	18	0	1	261
7:45:00 AM	12	96	6	0	114	0	0	22	45	11	0	78	0	1	7	117	0	0	125	0	0	2	16	10	0	28	0	0	345
8:00:00 AM	21	111	3	0	135	0	1	16	40	6	0	65	0	0	8	84	4	0	96	0	0	4	26	8	0	40	0	0	336
8:15:00 AM	65	94	9	0	119	0	0	10	37	10	0	57	0	0	4	83	0	0	87	0	0	3	19	5	0	27	0	0	290
<b>Grand Total</b>	<b>60</b>	<b>375</b>	<b>25</b>	<b>0</b>	<b>461</b>	<b>0</b>	<b>1</b>	<b>65</b>	<b>150</b>	<b>33</b>	<b>0</b>	<b>250</b>	<b>0</b>	<b>1</b>	<b>22</b>	<b>378</b>	<b>7</b>	<b>0</b>	<b>408</b>	<b>0</b>	<b>2</b>	<b>9</b>	<b>73</b>	<b>31</b>	<b>0</b>	<b>113</b>	<b>0</b>	<b>1</b>	<b>1232</b>
<b>% Approach</b>	13.0%	81.6%	5.4%	0.0%	<b>0.0%</b>	0.0%	0.0%	26.4%	60.0%	13.2%	0.0%	<b>0.0%</b>	0.0%	0.0%	5.4%	92.6%	1.7%	0.0%	<b>0.0%</b>	0.0%	0.0%	8.0%	64.6%	27.4%	0.0%	<b>0.0%</b>	0.0%	0.0%	8.0%
<b>% Total</b>	4.9%	30.5%	2.0%	0.0%	<b>37.4%</b>	0.0%	0.0%	5.4%	12.2%	2.7%	0.0%	<b>20.3%</b>	0.0%	0.0%	1.8%	30.7%	0.6%	0.0%	<b>33.1%</b>	0.0%	0.0%	0.7%	5.9%	2.5%	0.0%	<b>9.2%</b>	0.0%	0.0%	6.1%
<b>PHF</b>	0.714	0.847	0.694	0.000	<b>0.854</b>	0.000	0.000	0.750	0.833	0.750	0.000	<b>0.801</b>	0.000	0.000	0.688	0.808	0.438	0.000	<b>0.816</b>	0.000	0.000	0.563	0.652	0.775	0.000	<b>0.706</b>	0.000	0.000	<b>0.893</b>
<b>Lights</b>	60	345	21	0	426	0	0	62	146	30	0	238	0	0	20	355	7	0	382	0	0	8	66	29	0	103	0	0	1149
<b>% Lights</b>	100.0%	91.8%	84.0%	0.0%	<b>92.4%</b>	0.0%	0.0%	83.9%	97.3%	90.9%	0.0%	<b>95.2%</b>	0.0%	0.0%	80.9%	93.9%	100.0%	0.0%	<b>93.6%</b>	0.0%	0.0%	88.9%	90.4%	93.5%	0.0%	<b>91.2%</b>	0.0%	0.0%	<b>93.3%</b>
<b>Trucks</b>	0	2	0	0	2	0	0	0	1	1	0	2	0	0	0	2	0	0	2	0	0	0	0	0	0	0	0	0	6
<b>% Trucks</b>	0.0%	0.5%	0.0%	0.0%	<b>0.4%</b>	0.0%	0.0%	0.0%	0.7%	3.0%	0.0%	<b>0.8%</b>	0.0%	0.0%	0.0%	0.5%	0.0%	0.0%	<b>0.5%</b>	0.0%	0.0%	0.0%	0.0%	0.0%	0.0%	<b>0.0%</b>	0.0%	0.0%	<b>0.5%</b>
<b>Buses</b>	0	29	4	0	33	0	0	4	3	2	0	9	0	0	2	21	0	0	23	0	0	1	7	2	0	10	0	0	75
<b>% Buses</b>	0.0%	7.7%	16.0%	0.0%	<b>0.0%</b>	0.0%	0.0%	6.1%	2.0%	6.1%	0.0%	<b>0.0%</b>	0.0%	0.0%	9.1%	5.6%	0.0%	0.0%	<b>0.0%</b>	0.0%	0.0%	11.1%	9.6%	6.5%	0.0%	<b>0.0%</b>	0.0%	0.0%	<b>6.1%</b>
<b>Pedestrians</b>	0	0	0	0	0	0	0	0	0	0	0	0	1	0	0	0	0	0	0	0	2	0	0	0	0	0	0	1	0
<b>% Pedestrians</b>	0.0%	0.0%	0.0%	0.0%	<b>0.0%</b>	0.0%	0.0%	0.0%	0.0%	0.0%	0.0%	<b>0.0%</b>	100.0%	0.0%	0.0%	0.0%	0.0%	0.0%	<b>0.0%</b>	0.0%	100.0%	0.0%	0.0%	0.0%	0.0%	<b>0.0%</b>	0.0%	100.0%	<b>0.0%</b>
<b>Bicycles on Crosswalk</b>	0	0	0	0	0	0	1	0	0	0	0	0	0	0	0	0	0	0	0	0	0	0	0	0	0	0	0	0	0
<b>% Bicycles on Crosswalk</b>	0.0%	0.0%	0.0%	0.0%	<b>0.0%</b>	0.0%	100.0%	0.0%	0.0%	0.0%	0.0%	<b>0.0%</b>	0.0%	0.0%	0.0%	0.0%	0.0%	0.0%	<b>0.0%</b>	0.0%	0.0%	0.0%	0.0%	0.0%	0.0%	<b>0.0%</b>	0.0%	0.0%	<b>0.0%</b>

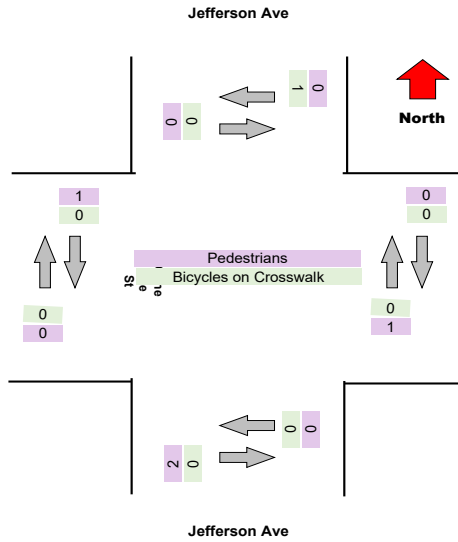
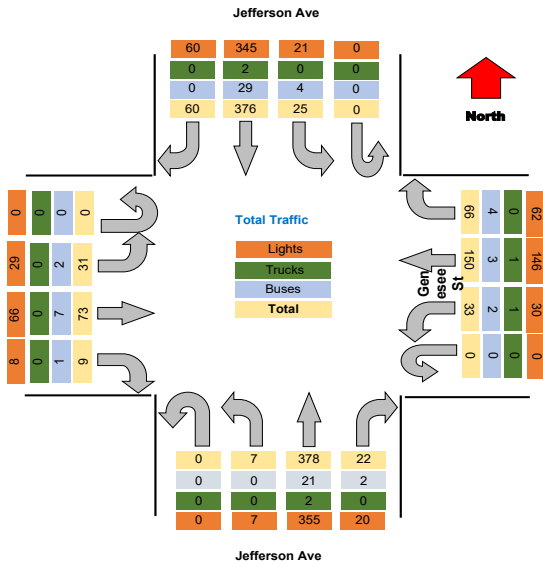

**Turning Movement Peak Hour Data (PM)**

4:15:00 PM

Leg Direction	Jefferson Ave										Genesee St										Total									
	Southbound					Westbound					Northbound					Eastbound														
	Right	Thru	Left	U-Turn	App Total	Peds CW	Peds CCW	Right	Thru	Left	U-Turn	App Total	Peds CW	Peds CCW	Right	Thru	Left	U-Turn	App Total	Peds CW		Peds CCW								
4:15:00 PM	23	125	14	0	162	0	0	16	40	8	0	64	0	0	6	135	3	0	144	2	0	11	26	11	0	48	3	4	418	
4:30:00 PM	24	124	12	0	160	1	0	24	29	18	0	71	0	0	8	109	1	0	118	0	0	8	29	8	0	45	0	0	394	
4:45:00 PM	26	103	9	0	138	0	0	17	24	11	0	52	0	0	15	108	3	0	126	1	0	3	30	8	0	41	1	0	357	
5:00:00 PM	30	116	9	0	149	0	0	11	25	9	0	45	1	0	13	133	3	0	149	0	0	6	25	9	0	40	1	0	383	
<b>Grand Total</b>	<b>103</b>	<b>462</b>	<b>44</b>	<b>0</b>	<b>609</b>	<b>1</b>	<b>0</b>	<b>68</b>	<b>118</b>	<b>46</b>	<b>0</b>	<b>232</b>	<b>1</b>	<b>0</b>	<b>42</b>	<b>495</b>	<b>10</b>	<b>0</b>	<b>537</b>	<b>3</b>	<b>0</b>	<b>29</b>	<b>110</b>	<b>36</b>	<b>0</b>	<b>174</b>	<b>5</b>	<b>4</b>	<b>1552</b>	
% Approach	16.9%	75.9%	7.2%	0.0%	0.0%	0.0%	0.0%	29.3%	50.9%	19.8%	0.0%	0.0%	0.0%	0.0%	7.8%	90.3%	1.9%	0.0%	0.0%	0.0%	0.0%	16.1%	63.2%	20.7%	0.0%	0.0%	0.0%	0.0%	0.0%	
% Total	6.6%	29.8%	2.8%	0.0%	38.2%	0.0%	0.0%	4.4%	7.6%	3.0%	0.0%	14.9%	0.0%	0.0%	2.7%	31.3%	0.6%	0.0%	34.6%	0.0%	0.0%	1.8%	7.1%	2.3%	0.0%	11.2%	0.0%	0.0%	0.0%	
PHF	0.858	0.924	0.786	0.000	0.940	0.000	0.000	0.708	0.738	0.639	0.000	0.817	0.000	0.000	0.700	0.898	0.833	0.000	0.801	0.000	0.000	0.636	0.917	0.818	0.000	0.906	0.000	0.000	0.928	
Lights	103	445	43	0	591	0	0	66	110	41	0	217	0	0	42	474	9	0	525	0	0	25	106	36	0	167	0	0	1500	
% Lights	100.0%	96.3%	97.7%	0.0%	97.0%	0.0%	0.0%	97.1%	93.2%	89.1%	0.0%	93.5%	0.0%	0.0%	100.0%	97.7%	90.0%	0.0%	97.8%	0.0%	0.0%	89.3%	96.4%	100.0%	0.0%	96.0%	0.0%	0.0%	96.6%	
Trucks	0	0	0	0	0	0	0	0	1	0	0	1	0	0	0	0	1	0	1	0	0	0	0	0	0	0	0	0	2	
% Trucks	0.0%	0.0%	0.0%	0.0%	0.0%	0.0%	0.0%	0.0%	0.8%	0.0%	0.0%	0.4%	0.0%	0.0%	0.0%	0.0%	10.0%	0.0%	0.2%	0.0%	0.0%	0.0%	0.0%	0.0%	0.0%	0.0%	0.0%	0.0%	0.1%	
Buses	0	17	1	0	18	0	0	2	6	3	0	11	0	0	0	11	0	0	11	0	0	3	4	0	0	7	0	0	47	
% Buses	0.0%	3.7%	2.3%	0.0%	0.0%	0.0%	0.0%	2.9%	5.1%	6.5%	0.0%	0.0%	0.0%	0.0%	0.0%	2.3%	0.0%	0.0%	0.0%	0.0%	0.0%	10.7%	3.8%	0.0%	0.0%	0.0%	0.0%	0.0%	3.0%	
Pedestrians	0	0	0	0	0	1	0	0	0	0	0	0	1	0	0	0	0	0	0	0	2	0	0	0	0	0	3	4	0	
% Pedestrians	0.0%	0.0%	0.0%	0.0%	0.0%	100.0%	0.0%	0.0%	0.0%	0.0%	0.0%	0.0%	100.0%	0.0%	0.0%	0.0%	0.0%	0.0%	0.0%	0.0%	66.7%	0.0%	0.0%	0.0%	0.0%	0.0%	0.0%	100.0%	0.0%	
Bicycles on Crosswalk	0	0	0	0	0	0	0	0	0	0	0	0	0	0	0	0	0	0	0	1	0	0	0	0	0	0	2	0	0	
% Bicycles on Crosswalk	0.0%	0.0%	0.0%	0.0%	0.0%	0.0%	0.0%	0.0%	0.0%	0.0%	0.0%	0.0%	0.0%	0.0%	0.0%	0.0%	0.0%	0.0%	0.0%	33.3%	0.0%	0.0%	0.0%	0.0%	0.0%	0.0%	0.0%	40.0%	0.0%	0.0%

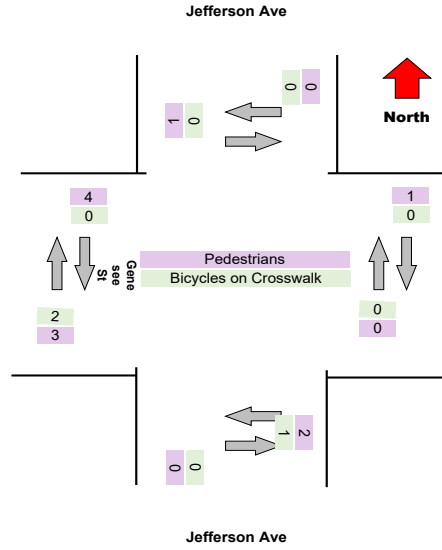
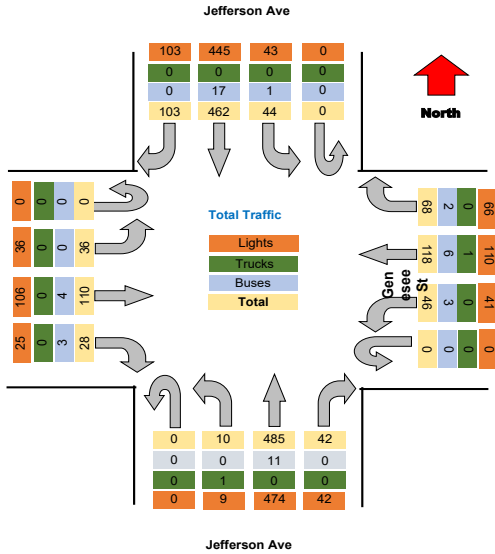

Survey Date : 2021-04-28, Wednesday

Project	LaBella
Project Code	LaBella
Site Name	12
Legs and Movements	All Processed Legs & Move
Bin Size	15 minutes
Survey Date	2021-11-04, Thursday
Location	12
Latitude and Longitude	42.896155, -78.853968

	Start	End	PHF
Forced Peak AM	2021/11/04 07:30:00	2021/11/04 08:30:00	0.92
Forced Peak PM	2021/11/04 16:30:00	2021/11/04 17:30:00	0.96
AM Peak	2021/11/04 07:30:00	2021/11/04 08:30:00	0.92
PM Peak	2021/11/04 16:15:00	2021/11/04 17:15:00	0.92

### Turning Movement Data

Leg Direction	Jefferson Ave Southbound						Genesee St Westbound						Jefferson Ave Northbound						Genesee St Eastbound						Total				
	Right	Thru	Left	U-Turn	App Total	Peds CV	Peds CCV	Right	Thru	Left	U-Turn	App Total	Peds CV	Peds CCV	Right	Thru	Left	U-Turn	App Total	Peds CV	Peds CCV	Right	Thru	Left		U-Turn	App Total	Peds CV	Peds CCV
	Start Time																												
6:30:00 AM	9	33	3	0	45	0	0	4	10	4	0	18	0	0	2	47	0	0	49	0	0	1	6	9	0	16	1	1	128
6:45:00 AM	6	43	6	0	55	0	0	12	21	6	0	39	0	0	4	49	0	0	53	0	0	0	6	9	0	15	0	0	162
Hourly Total	15	76	9	0	100	0	0	16	31	10	0	57	0	0	6	96	0	0	102	0	0	1	12	18	0	31	1	1	230
7:00:00 AM	6	37	3	0	46	0	0	8	17	0	0	23	0	0	4	57	1	0	62	0	0	1	8	6	0	15	0	0	146
7:15:00 AM	9	54	3	0	66	0	0	10	24	2	0	36	0	0	4	66	1	0	71	0	0	1	13	3	0	17	0	1	190
7:30:00 AM	10	80	6	0	96	0	0	18	35	8	0	61	0	0	2	92	1	0	95	0	1	2	15	7	0	24	2	2	276
7:45:00 AM	8	84	7	0	99	0	1	22	38	11	0	72	0	0	8	111	2	0	121	0	0	2	10	4	0	16	0	0	308
Hourly Total	33	255	19	0	307	0	1	56	114	21	0	192	0	0	18	326	5	0	349	0	1	6	46	20	0	72	2	3	920
8:00:00 AM	20	92	3	0	115	0	0	17	33	5	0	55	1	0	8	110	0	0	119	0	0	4	27	7	0	38	0	0	327
8:15:00 AM	17	98	8	0	123	0	0	12	29	5	0	46	1	0	6	83	4	0	94	0	0	1	22	3	0	26	1	0	289
Hourly Total	37	190	11	0	238	0	0	29	62	10	0	101	2	0	14	193	4	0	213	0	0	5	49	10	0	64	1	0	616
4:00:00 PM	24	131	17	0	172	0	0	7	31	16	0	54	0	0	11	86	2	0	99	0	1	11	39	13	0	63	0	0	388
4:15:00 PM	33	134	12	0	179	0	0	18	39	15	0	72	0	2	10	110	4	0	124	0	2	5	25	12	0	42	0	0	417
4:30:00 PM	21	107	11	0	139	0	0	12	25	7	0	44	2	0	9	137	5	0	151	1	0	10	35	5	0	50	0	0	384
4:45:00 PM	23	102	11	0	136	0	0	11	32	16	0	59	2	2	11	117	2	0	130	0	0	1	32	8	0	41	1	1	366
Hourly Total	101	474	51	0	628	0	0	48	127	54	0	229	4	4	41	450	13	0	504	1	3	27	131	38	0	196	1	1	1555
5:00:00 PM	32	97	3	0	132	0	0	18	19	22	0	59	0	1	12	113	3	0	128	0	0	8	36	10	0	54	0	1	373
5:15:00 PM	28	104	10	0	142	0	0	13	25	12	0	50	0	0	8	100	2	0	110	0	0	3	31	10	0	44	0	0	346
5:30:00 PM	15	96	9	0	120	1	2	13	20	10	0	43	0	1	17	111	9	0	137	0	1	2	26	5	0	33	0	4	333
5:45:00 PM	18	110	5	0	133	0	0	18	31	12	0	61	1	0	5	89	5	0	99	0	2	8	18	8	0	34	0	3	327
Hourly Total	83	407	27	0	527	1	2	62	95	56	0	213	1	2	42	413	19	0	474	0	3	21	111	33	0	165	0	8	1379
Grand Total	279	1402	117	0	1798	1	3	211	429	151	0	792	7	6	121	1478	41	0	1642	1	7	60	349	119	0	528	5	13	4780
% Approach	15.5%	78.0%	6.5%	0.0%	0.0%	0.0%	0.0%	26.6%	54.2%	19.1%	0.0%	0.0%	0.0%	0.0%	7.4%	90.0%	2.5%	0.0%	0.0%	0.0%	0.0%	11.4%	66.1%	22.5%	0.0%	0.0%	0.0%	0.0%	0.0%
% Total	5.9%	29.5%	2.5%	0.0%	37.8%	0.0%	0.0%	4.4%	30.0%	3.2%	0.0%	16.6%	0.0%	0.0%	2.5%	31.1%	0.9%	0.0%	34.5%	0.0%	0.0%	1.3%	7.3%	2.5%	0.0%	11.1%	0.0%	0.0%	0.0%
Lights	277	1336	112	0	1725	0	0	205	414	139	0	758	0	0	117	1429	40	0	1586	0	0	58	325	113	0	496	0	0	4565
% Lights	99.3%	95.3%	95.7%	0.0%	95.9%	0.0%	0.0%	97.2%	96.9%	92.1%	0.0%	95.7%	0.0%	0.0%	96.7%	96.7%	97.8%	0.0%	96.6%	0.0%	0.0%	96.7%	93.1%	95.0%	0.0%	93.9%	0.0%	0.0%	95.9%
Trucks	0	0	0	0	0	0	0	1	0	11	0	2	0	0	1	4	0	0	5	0	0	0	3	0	0	3	0	0	10
% Trucks	0.0%	0.0%	0.0%	0.0%	0.0%	0.0%	0.0%	0.5%	0.0%	0.7%	0.0%	0.3%	0.0%	0.0%	0.8%	0.3%	0.0%	0.0%	0.3%	0.0%	0.0%	0.0%	0.9%	0.0%	0.0%	0.6%	0.0%	0.0%	0.2%
Buses	2	64	5	0	71	0	0	5	15	11	0	31	0	0	3	44	1	0	48	0	0	2	20	6	0	28	0	0	178
% Buses	0.7%	4.6%	4.3%	0.0%	0.0%	0.0%	0.0%	0.0%	3.5%	7.3%	0.0%	0.0%	0.0%	0.0%	2.5%	3.0%	2.4%	0.0%	0.0%	0.0%	0.0%	3.3%	5.7%	5.0%	0.0%	0.0%	0.0%	3.7%	
Pedestrians	0	0	0	0	0	1	2	0	0	0	0	0	7	6	0	0	0	0	0	1	7	0	0	0	0	0	5	12	0
% Pedestrians	0.0%	0.0%	0.0%	0.0%	0.0%	100.0%	66.7%	0.0%	0.0%	0.0%	0.0%	0.0%	100.0%	100.0%	0.0%	0.0%	0.0%	0.0%	0.0%	0.0%	100.0%	0.0%	0.0%	0.0%	0.0%	0.0%	0.0%	62.3%	0.0%
Bicycles on Crosswalk	0	0	0	0	0	0	1	0	0	0	0	0	0	0	0	0	0	0	0	0	0	0	0	0	0	0	0	1	0
% Bicycles on Crosswalk	0.0%	0.0%	0.0%	0.0%	0.0%	0.0%	33.3%	0.0%	0.0%	0.0%	0.0%	0.0%	0.0%	0.0%	0.0%	0.0%	0.0%	0.0%	0.0%	0.0%	0.0%	0.0%	0.0%	0.0%	0.0%	0.0%	0.0%	7.7%	0.0%

Project : VBH Malta NY  
 Site : Site 4  
 Location : 42.948550, -73.790036  
 Survey Date : 2021-04-28, Wednesday

### Turning Movement Data Plot

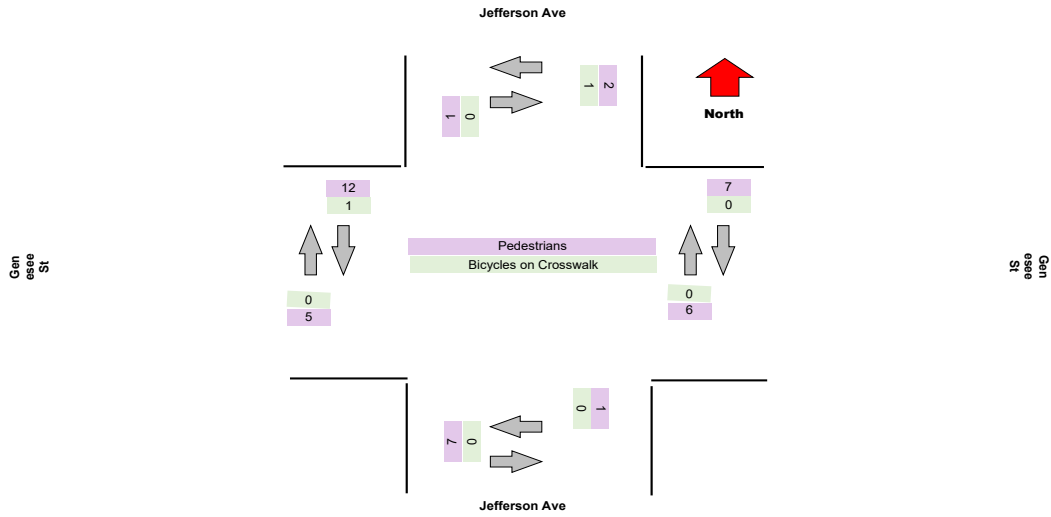
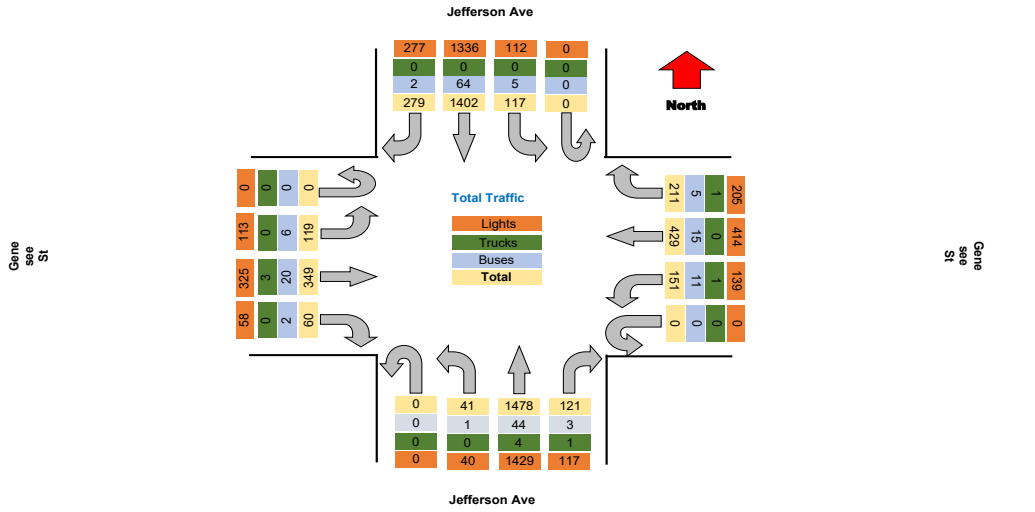

Project : VBH Malta NY  
Site : Site 4  
Location : 42.948550, -73.790036  
Survey Date : 2021-04-28, Wednesday

TSTData.com

**Turning Movement Peak Hour Data (AM)**

7:30:00 AM

Leg Direction	Jefferson Ave				Genesee St				Jefferson Ave				Genesee St				Total														
	Right	Thru	Left	U-Turn	Right	Thru	Left	U-Turn	Right	Thru	Left	U-Turn	Right	Thru	Left	U-Turn															
Start Time	Right	Thru	Left	U-Turn	App Total	Peds CW	Peds CCW	Right	Thru	Left	U-Turn	App Total	Peds CW	Peds CCW	Right	Thru	Left	U-Turn	App Total	Peds CW	Peds CCW	Total									
7:30:00 AM	10	80	6	0	96	0	0	18	35	8	0	61	0	0	2	92	1	0	95	0	1	2	15	7	0	24	2	2	276		
7:45:00 AM	8	84	7	0	99	0	1	22	38	11	0	72	0	0	8	111	2	0	121	0	0	2	10	4	0	16	0	0	308		
8:00:00 AM	20	92	3	0	115	0	0	17	33	5	0	55	1	0	8	110	0	0	119	0	0	4	27	7	0	38	0	0	327		
8:15:00 AM	17	98	8	0	123	0	0	12	29	5	0	46	1	0	6	83	4	0	94	0	0	1	22	3	0	26	1	0	289		
Grand Total	55	354	24	0	433	0	1	69	135	29	0	234	2	0	24	395	7	0	429	0	1	9	74	21	0	104	3	2	1280		
% Approach	12.7%	81.8%	5.5%	0.0%	0.0%	0.0%	0.0%	29.5%	57.7%	12.4%	0.0%	0.0%	0.0%	0.0%	5.6%	92.3%	1.6%	0.0%	0.0%	0.0%	0.0%	8.7%	71.2%	20.2%	0.0%	0.0%	0.0%	0.0%	0.0%		
% Total	4.6%	29.5%	2.0%	0.0%	36.1%	0.0%	0.0%	5.8%	11.3%	2.4%	0.0%	19.5%	0.0%	0.0%	2.0%	33.0%	0.6%	0.0%	35.8%	0.0%	0.0%	0.8%	6.2%	1.8%	0.0%	8.7%	0.0%	0.0%	0.0%		
PHF	0.688	0.903	0.750	0.000	0.880	0.000	0.000	0.784	0.888	0.659	0.000	0.813	0.000	0.000	0.750	0.892	0.438	0.000	0.886	0.000	0.000	0.563	0.685	0.750	0.000	0.684	0.000	0.000	0.917		
Lights	55	328	20	0	403	0	0	66	133	25	0	224	0	0	22	374	7	0	403	0	0	8	69	19	0	96	0	0	1126		
% Lights	100.0%	92.7%	83.3%	0.0%	93.1%	0.0%	0.0%	95.7%	98.5%	86.2%	0.0%	95.7%	0.0%	0.0%	91.7%	94.4%	100.0%	0.0%	93.9%	0.0%	0.0%	88.9%	93.2%	90.5%	0.0%	92.3%	0.0%	0.0%	93.8%		
Trucks	0	0	0	0	0	0	0	1	0	1	0	2	0	0	1	2	0	0	3	0	0	0	2	0	0	2	0	0	7		
% Trucks	0.0%	0.0%	0.0%	0.0%	0.0%	0.0%	0.0%	1.4%	0.0%	3.4%	0.0%	0.9%	0.0%	0.0%	4.2%	0.5%	0.0%	0.0%	0.7%	0.0%	0.0%	0.0%	2.7%	0.0%	0.0%	1.9%	0.0%	0.0%	0.6%		
Buses	0	26	4	0	30	0	0	2	2	3	0	7	0	0	1	20	0	0	21	0	0	1	3	2	0	6	0	0	64		
% Buses	0.0%	7.3%	16.7%	0.0%	0.0%	0.0%	0.0%	2.9%	1.5%	10.3%	0.0%	0.0%	0.0%	0.0%	4.2%	5.1%	0.0%	0.0%	0.0%	0.0%	0.0%	11.1%	4.1%	9.5%	0.0%	0.0%	0.0%	0.0%	5.3%		
Pedestrians	0	0	0	0	0	0	0	0	0	0	0	2	0	0	0	0	0	0	0	0	1	0	0	0	0	0	0	3	2	0	
% Pedestrians	0.0%	0.0%	0.0%	0.0%	0.0%	0.0%	0.0%	0.0%	0.0%	0.0%	0.0%	0.8%	0.0%	0.0%	0.0%	0.0%	0.0%	0.0%	0.0%	0.0%	100.0%	0.0%	0.0%	0.0%	0.0%	0.0%	0.0%	0.9%	100.0%	100.0%	0.0%
Bicycles on Crosswalk	0	0	0	0	0	0	1	0	0	0	0	0	0	0	0	0	0	0	0	0	0	0	0	0	0	0	0	0	0		
% Bicycles on Crosswalk	0.0%	0.0%	0.0%	0.0%	0.0%	0.0%	100.0%	0.0%	0.0%	0.0%	0.0%	0.0%	0.0%	0.0%	0.0%	0.0%	0.0%	0.0%	0.0%	0.0%	0.0%	0.0%	0.0%	0.0%	0.0%	0.0%	0.0%	0.0%	0.0%	0.0%	

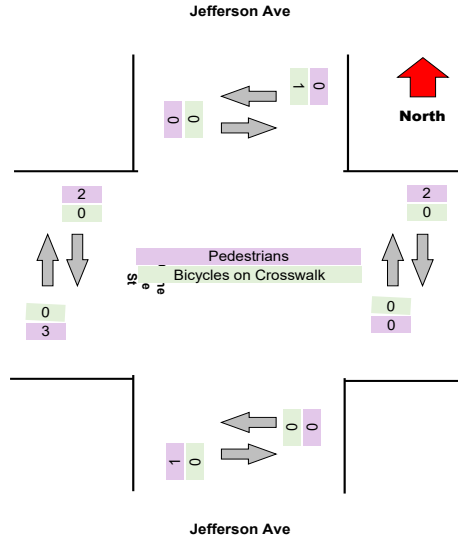
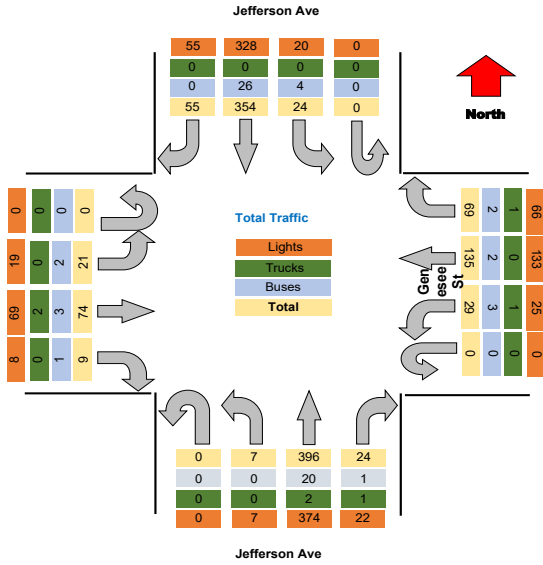



Project : VBH Malta NY  
Site : Site 4  
Location : 42.948550, -73.790036

TSTData.com

Survey Date : 2021-04-28, Wednesday

### Turning Movement Peak Hour Data (PM)

4:15:00 PM

Leg Direction	Jefferson Ave				Genesee St				Jefferson Ave				Genesee St				Total				
	Southbound		Northbound		Westbound		Eastbound		Northbound		Southbound		Westbound		Eastbound						
Start Time	Right	Thru	Left	U-Turn	App Total	Peds CW	Peds CCW	Right	Thru	Left	U-Turn	App Total	Peds CW	Peds CCW	Right	Thru	Left	U-Turn	App Total	Peds CW	Peds CCW
4:15:00 PM	33	134	12	0	179	0	0	18	39	15	0	72	0	2	10	110	4	0	124	0	2
4:30:00 PM	21	107	11	0	139	0	0	12	25	7	0	44	2	0	9	137	5	0	151	1	0
4:45:00 PM	23	102	11	0	136	0	0	11	32	16	0	59	2	2	11	117	2	0	130	0	0
5:00:00 PM	32	97	3	0	132	0	0	18	19	22	0	59	0	0	12	113	3	0	128	0	0
<b>Grand Total</b>	<b>109</b>	<b>440</b>	<b>37</b>	<b>0</b>	<b>586</b>	<b>0</b>	<b>0</b>	<b>59</b>	<b>115</b>	<b>60</b>	<b>0</b>	<b>234</b>	<b>2</b>	<b>2</b>	<b>42</b>	<b>477</b>	<b>14</b>	<b>0</b>	<b>533</b>	<b>1</b>	<b>2</b>
% Approach	18.6%	75.1%	6.3%	0.0%	0.0%	0.0%	0.0%	25.2%	49.1%	25.6%	0.0%	0.0%	0.0%	0.0%	7.9%	89.5%	2.6%	0.0%	0.0%	0.0%	0.0%
% Total	7.1%	28.6%	2.4%	0.0%	38.1%	0.0%	0.0%	3.8%	7.5%	3.9%	0.0%	15.2%	0.0%	0.0%	2.7%	31.0%	0.9%	0.0%	34.6%	0.0%	0.0%
PHF	0.826	0.821	0.771	0.000	0.818	0.000	0.000	0.819	0.737	0.682	0.000	0.813	0.000	0.000	0.875	0.870	0.700	0.000	0.882	0.000	0.000
Lights	108	421	37	0	566	0	0	58	109	55	0	222	0	0	42	465	14	0	521	0	0
% Lights	99.1%	95.7%	100.0%	0.0%	96.6%	0.0%	0.0%	98.3%	94.8%	91.7%	0.0%	94.9%	0.0%	0.0%	100.0%	97.6%	100.0%	0.0%	97.7%	0.0%	0.0%
Trucks	0	0	0	0	0	0	0	0	0	0	0	0	0	0	0	1	0	0	1	0	0
% Trucks	0.0%	0.0%	0.0%	0.0%	0.0%	0.0%	0.0%	0.0%	0.0%	0.0%	0.0%	0.0%	0.0%	0.0%	0.0%	0.2%	0.0%	0.0%	0.2%	0.0%	0.0%
Buses	1	19	0	0	20	0	0	1	6	5	0	12	0	0	0	10	0	0	10	0	0
% Buses	0.9%	4.3%	0.0%	0.0%	0.0%	0.0%	0.0%	1.7%	5.2%	8.3%	0.0%	0.0%	0.0%	0.0%	0.0%	2.1%	0.0%	0.0%	0.0%	0.0%	0.0%
Pedestrians	0	0	0	0	0	0	0	0	0	0	0	4	5	0	0	0	0	0	1	2	0
% Pedestrians	0.0%	0.0%	0.0%	0.0%	0.0%	0.0%	0.0%	0.0%	0.0%	0.0%	0.0%	100.0%	100.0%	0.0%	0.0%	0.0%	0.0%	0.0%	0.6%	100.0%	100.0%
Bicycles on Crosswalk	0	0	0	0	0	0	0	0	0	0	0	0	0	0	0	0	0	0	0	0	0
% Bicycles on Crosswalk	0.0%	0.0%	0.0%	0.0%	0.0%	0.0%	0.0%	0.0%	0.0%	0.0%	0.0%	0.0%	0.0%	0.0%	0.0%	0.0%	0.0%	0.0%	0.0%	0.0%	0.0%

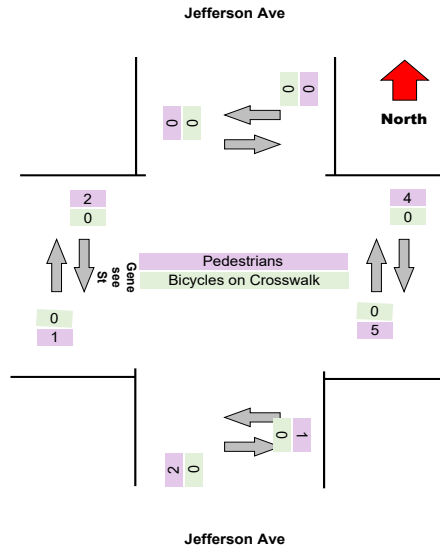
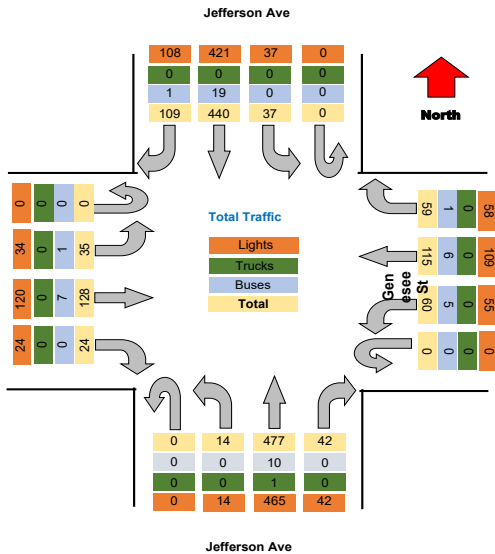

Project : VBH Malta NY  
 Site : Site 4  
 Location : 42.948550, -73.790036

TSTData.com

Survey Date : 2021-04-28, Wednesday

Project	Labella
Project Code	Labella
Site Name	13
Legs and Movements	All Processed Legs & Move
Bin Size	15 minutes
Survey Date	2021-10-26, Tuesday
Location	13
Latitude and Longitude	42.900130, -78.844602

	Start	End	PHF
Forced Peak AM	2021/10/26 07:30:00	2021/10/26 08:30:00	0.81
Forced Peak PM	2021/10/26 16:30:00	2021/10/26 17:30:00	0.88
AM Peak	2021/10/26 07:30:00	2021/10/26 08:30:00	0.81
PM Peak	2021/10/26 16:30:00	2021/10/26 17:30:00	0.88

### Turning Movement Data

Leg Direction	Herman St Southbound					Genesee St Westbound					Herman St Northbound					Genesee St Eastbound					Total														
	Right	Thru	Left	U-Turn	App Total	Right	Thru	Left	U-Turn	App Total	Right	Thru	Left	U-Turn	App Total	Right	Thru	Left	U-Turn	App Total															
	Peds	CV	Peds	CV	Peds	CV	Peds	CV	Peds	CV	Peds	CV	Peds	CV	Peds	CV	Peds	CV	Peds	CV		Peds	CV												
Start Time	1	7	3	0	11	0	0	0	1	21	0	0	0	22	0	0	0	0	0	5	2	0	7	0	0	0	1	14	2	0	17	0	0	57	
6:30:00 AM	3	16	3	0	22	0	0	0	1	53	1	0	0	55	0	0	0	0	0	0	6	2	0	8	0	0	0	0	17	2	0	19	0	0	104
6:45:00 AM	4	23	6	0	33	0	0	0	2	74	1	0	0	77	0	0	0	0	0	0	11	4	0	15	0	0	1	31	4	0	36	0	0	161	
Hourly Total	2	13	2	0	17	0	0	0	0	39	1	0	0	40	1	0	0	0	0	7	1	0	8	1	2	1	23	0	0	24	0	0	90		
7:00:00 AM	1	9	2	0	12	0	0	0	2	36	1	0	0	39	0	0	0	0	0	1	8	3	0	12	1	1	1	20	2	0	23	1	0	86	
7:15:00 AM	2	16	3	0	21	1	0	0	2	73	1	0	0	76	0	0	0	0	0	2	12	1	0	15	0	0	0	18	1	0	19	0	0	131	
7:30:00 AM	5	24	3	0	32	0	0	0	3	100	4	0	0	107	0	0	0	0	0	3	19	7	0	29	0	0	2	37	0	0	39	0	0	207	
7:45:00 AM	10	62	10	0	82	1	0	0	7	248	7	0	0	262	1	0	0	0	0	6	46	12	0	65	2	3	4	98	3	0	105	1	0	514	
Hourly Total	11	21	5	0	37	0	0	0	4	98	5	0	0	105	0	0	0	0	0	0	14	4	0	18	0	0	3	55	2	0	60	0	0	220	
8:00:00 AM	3	21	6	0	30	1	0	0	3	75	1	0	0	79	0	0	0	0	0	1	10	2	0	13	0	0	0	32	0	0	32	0	0	154	
8:15:00 AM	14	42	11	0	67	1	0	0	7	171	6	0	0	184	0	0	0	0	0	1	24	6	0	31	0	0	3	87	2	0	92	0	0	374	
Hourly Total	1	37	9	0	47	0	0	0	7	69	2	0	0	78	0	0	0	0	0	4	31	7	0	42	0	0	6	86	1	0	93	0	0	260	
4:00:00 PM	3	26	11	0	40	0	0	0	6	77	5	0	0	88	0	0	0	0	0	3	25	5	0	33	0	0	2	58	1	0	61	0	0	222	
4:15:00 PM	5	39	9	0	53	0	2	0	1	57	2	0	0	60	0	1	0	0	0	11	19	7	0	37	0	0	7	97	2	0	106	0	0	256	
4:30:00 PM	4	33	3	0	40	2	1	0	5	58	4	0	0	67	0	0	0	0	0	6	23	8	0	37	0	0	3	78	1	0	82	0	0	226	
4:45:00 PM	13	135	32	0	180	2	3	0	19	261	13	0	0	293	0	1	0	0	0	24	98	27	0	149	0	0	18	319	5	0	342	0	0	964	
Hourly Total	3	35	7	0	45	0	0	0	3	60	4	0	0	67	0	0	0	0	0	9	17	9	0	35	0	0	4	72	1	0	77	0	0	224	
5:00:00 PM	3	29	5	0	37	0	1	0	6	47	5	0	0	58	0	0	0	0	0	6	20	5	0	31	0	0	5	82	3	0	70	0	0	196	
5:15:00 PM	4	34	6	0	44	0	1	0	7	53	5	0	0	65	0	0	0	0	0	6	20	4	0	30	0	0	2	44	0	0	46	0	0	185	
5:30:00 PM	1	33	7	0	41	0	0	0	4	63	4	0	0	71	0	0	0	0	0	8	24	5	0	37	0	0	3	36	2	0	41	0	0	190	
5:45:00 PM	11	131	25	0	167	0	2	0	20	223	18	0	0	261	0	0	0	0	0	29	81	23	0	133	0	0	14	214	6	0	234	0	0	795	
Hourly Total	52	393	84	0	529	4	5	0	55	977	45	0	0	1077	1	1	0	0	0	60	260	72	0	393	2	3	40	749	20	0	809	1	0	2898	
Grand Total	9.8%	74.3%	15.9%	0.0%	0.0%	0.0%	0.0%	0.0%	5.1%	90.7%	4.2%	0.0%	0.0%	0.0%	0.0%	0.0%	0.0%	0.0%	15.3%	66.2%	18.3%	0.0%	0.0%	0.0%	0.0%	0.0%	4.9%	92.6%	2.5%	0.0%	0.0%	0.0%	0.0%	0.0%	
% Approach	1.9%	14.0%	3.0%	0.0%	18.8%	0.0%	0.0%	0.0%	2.0%	34.8%	1.6%	0.0%	0.0%	0.0%	0.0%	0.0%	0.0%	0.0%	2.1%	9.3%	2.6%	0.0%	14.0%	0.0%	0.0%	1.4%	26.7%	0.7%	0.0%	28.8%	0.0%	0.0%	0.0%		
% Total	48	388	80	0	516	0	0	0	51	941	43	0	0	1035	0	0	0	0	0	55	253	71	0	379	0	0	37	707	15	0	759	0	0	2689	
Lights	92.3%	98.7%	95.2%	0.0%	97.5%	0.0%	0.0%	0.0%	92.7%	96.3%	95.6%	0.0%	96.1%	0.0%	0.0%	0.0%	0.0%	0.0%	91.7%	97.3%	98.6%	0.0%	96.4%	0.0%	0.0%	92.5%	94.4%	75.0%	0.0%	93.8%	0.0%	0.0%	95.6%		
% Lights	0	0	0	0	0	0	0	0	0	2	0	0	2	0	0	0	0	0	0	0	0	0	0	0	0	0	0	0	0	0	0	0	2		
Trucks	0.0%	0.0%	0.0%	0.0%	0.0%	0.0%	0.0%	0.0%	0.0%	0.2%	0.0%	0.0%	0.2%	0.0%	0.0%	0.0%	0.0%	0.0%	0.0%	0.0%	0.0%	0.0%	0.0%	0.0%	0.0%	0.0%	0.0%	0.0%	0.0%	0.0%	0.0%	0.0%	0.0%	0.1%	
% Trucks	4	5	4	0	13	0	0	0	4	34	2	0	0	40	0	0	0	0	5	7	1	0	13	0	0	3	42	5	0	50	0	0	116		
Buses	7.7%	1.3%	4.8%	0.0%	0.0%	0.0%	0.0%	0.0%	0.0%	3.5%	4.4%	0.0%	0.0%	0.0%	0.0%	0.0%	0.0%	0.0%	8.3%	2.7%	1.4%	0.0%	0.0%	0.0%	0.0%	7.5%	5.6%	25.0%	0.0%	0.0%	0.0%	4.1%			
% Buses	0	0	0	0	0	4	4	0	0	0	0	0	0	1	1	0	0	0	0	0	0	0	0	0	2	2	0	0	0	0	1	0	0		
Pedestrians	0.0%	0.0%	0.0%	0.0%	0.0%	100.0%	80.0%	0.0%	0.0%	0.0%	0.0%	0.0%	0.0%	0.0%	0.0%	100.0%	100.0%	0.0%	0.0%	0.0%	0.0%	0.0%	0.0%	0.0%	0.0%	100.0%	66.7%	0.0%	0.0%	0.0%	0.0%	0.0%	0.0%		
% Pedestrians	0	0	0	0	0	0	1	0	0	0	0	0	0	0	0	0	0	0	0	0	0	0	0	0	0	0	0	0	0	0	0	0	0		
Bicycles on Crosswalk	0.0%	0.0%	0.0%	0.0%	0.0%	0.0%	20.0%	0.0%	0.0%	0.0%	0.0%	0.0%	0.0%	0.0%	0.0%	0.0%	0.0%	0.0%	0.0%	0.0%	0.0%	0.0%	0.0%	0.0%	0.0%	0.0%	0.0%	0.0%	0.0%	0.0%	0.0%	0.0%	0.0%		
% Bicycles on Crosswalk																																			

Project : VBH Malta NY  
 Site : Site 4  
 Location : 42.948550, -73.790036  
 Survey Date : 2021-04-28, Wednesday

### Turning Movement Data Plot

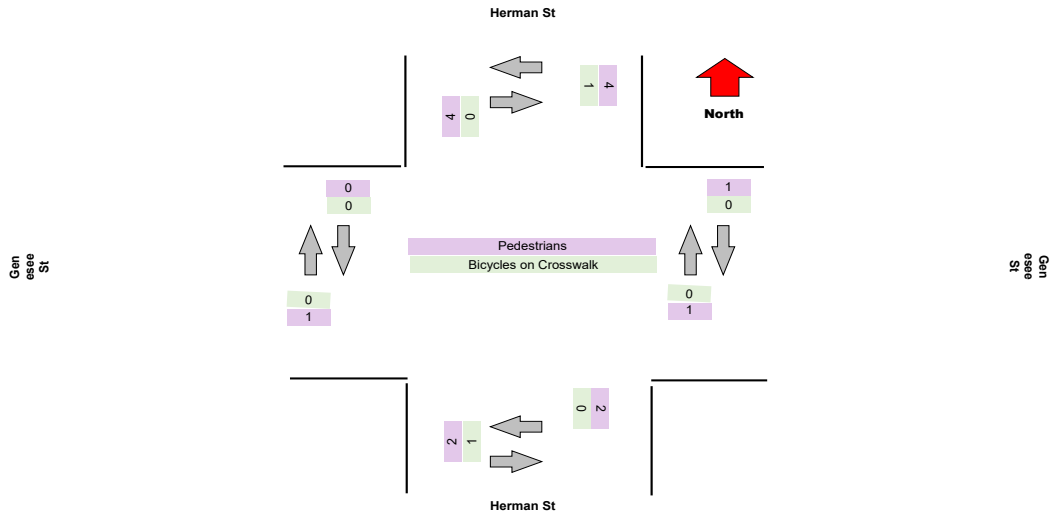
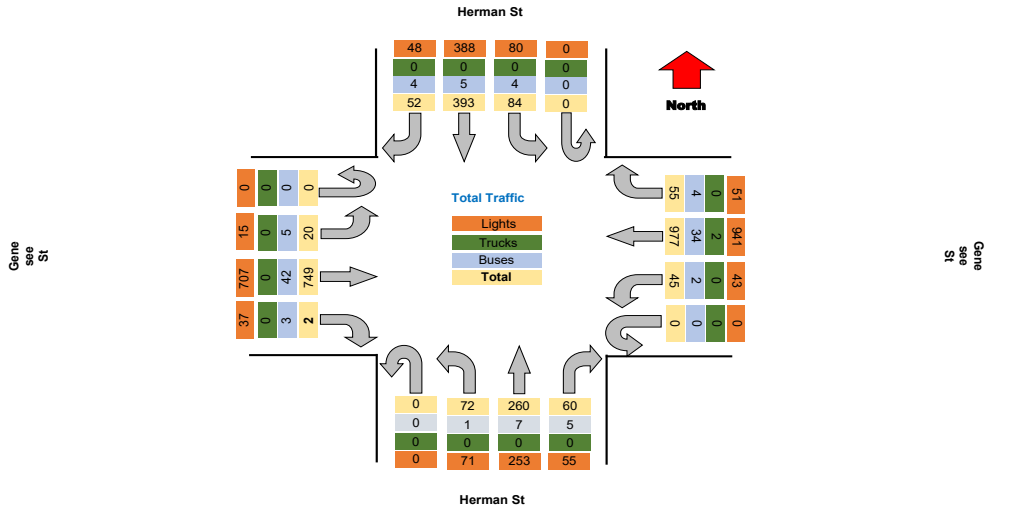

Project : VBH Malta NY  
Site : Site 4  
Location : 42.948550, -73.790036

TSTData.com

Survey Date : 2021-04-28, Wednesday

**Turning Movement Peak Hour Data (AM)**

7:30:00 AM

Leg Direction	Herman St Southbound					Genesee St Westbound					Herman St Northbound					Genesee St Eastbound					Total						
	Right	Thru	Left	U-Turn	App Total	Peds CW	Peds CCW	Right	Thru	Left	U-Turn	App Total	Peds CW	Peds CCW	Right	Thru	Left	U-Turn	App Total	Peds CW		Peds CCW					
7:30:00 AM	2	16	3	0	21	1	0	2	73	1	0	76	0	0	2	12	1	0	15	0	0	19	0	0	131		
7:45:00 AM	5	24	3	0	32	0	0	3	100	4	0	107	0	0	3	19	7	0	29	0	0	2	37	0	0	207	
8:00:00 AM	11	21	5	0	37	0	0	4	96	5	0	105	0	0	0	14	4	0	18	0	0	3	55	2	0	60	
8:15:00 AM	3	21	6	0	30	1	0	3	75	1	0	79	0	0	1	10	2	0	13	0	0	0	32	0	0	32	
<b>Grand Total</b>	<b>21</b>	<b>82</b>	<b>17</b>	<b>0</b>	<b>120</b>	<b>2</b>	<b>0</b>	<b>12</b>	<b>344</b>	<b>11</b>	<b>0</b>	<b>357</b>	<b>0</b>	<b>0</b>	<b>6</b>	<b>55</b>	<b>14</b>	<b>0</b>	<b>75</b>	<b>0</b>	<b>0</b>	<b>5</b>	<b>142</b>	<b>3</b>	<b>0</b>	<b>712</b>	
% Approach	17.5%	68.3%	14.2%	0.0%	0.0%	0.0%	0.0%	14.2%	85.8%	0.0%	0.0%	0.0%	0.0%	0.0%	45.1%	41.7%	13.2%	0.0%	0.0%	0.0%	0.0%	0.0%	66.2%	33.8%	0.0%	0.0%	0.0%
% Total	2.9%	11.5%	2.4%	0.0%	16.8%	0.0%	0.0%	1.7%	48.3%	1.5%	0.0%	51.5%	0.0%	0.0%	0.8%	7.7%	2.0%	0.0%	10.5%	0.0%	0.0%	0.7%	19.9%	0.4%	0.0%	21.1%	
PHF	0.477	0.854	0.708	0.000	0.811	0.000	0.000	0.750	0.880	0.550	0.000	0.857	0.000	0.000	0.500	0.724	0.500	0.000	0.647	0.000	0.000	0.417	0.645	0.375	0.000	0.625	
Lights	20	81	17	0	118	0	0	11	331	11	0	353	0	0	4	51	14	0	69	0	0	5	127	2	0	134	
% Lights	95.2%	98.8%	100.0%	0.0%	98.3%	0.0%	0.0%	91.7%	96.2%	100.0%	0.0%	96.2%	0.0%	0.0%	66.7%	92.7%	100.0%	0.0%	92.0%	0.0%	0.0%	100.0%	89.4%	66.7%	0.0%	89.3%	
Trucks	0	0	0	0	0	0	0	0	1	0	0	1	0	0	0	0	0	0	0	0	0	0	0	0	0	0	1
% Trucks	0.0%	0.0%	0.0%	0.0%	0.0%	0.0%	0.0%	0.0%	0.3%	0.0%	0.0%	0.3%	0.0%	0.0%	0.0%	0.0%	0.0%	0.0%	0.0%	0.0%	0.0%	0.0%	0.0%	0.0%	0.0%	0.0%	0.1%
Buses	1	1	0	0	2	0	0	1	12	0	0	13	0	0	2	4	0	0	6	0	0	0	15	1	0	16	
% Buses	4.8%	1.2%	0.0%	0.0%	0.0%	0.0%	0.0%	8.3%	3.5%	0.0%	0.0%	0.0%	0.0%	0.0%	33.3%	7.3%	0.0%	0.0%	0.0%	0.0%	0.0%	0.0%	10.6%	33.3%	0.0%	0.0%	
Pedestrians	0	0	0	0	0	2	0	0	0	0	0	0	0	0	0	0	0	0	0	0	0	0	0	0	0	0	
% Pedestrians	0.0%	0.0%	0.0%	0.0%	0.0%	100.0%	0.0%	0.0%	0.0%	0.0%	0.0%	0.0%	0.0%	0.0%	0.0%	0.0%	0.0%	0.0%	0.0%	0.0%	0.0%	0.0%	0.0%	0.0%	0.0%	0.0%	
Bicycles on Crosswalk	0	0	0	0	0	0	0	0	0	0	0	0	0	0	0	0	0	0	0	0	0	0	0	0	0	0	
% Bicycles on Crosswalk	0.0%	0.0%	0.0%	0.0%	0.0%	0.0%	0.0%	0.0%	0.0%	0.0%	0.0%	0.0%	0.0%	0.0%	0.0%	0.0%	0.0%	0.0%	0.0%	0.0%	0.0%	0.0%	0.0%	0.0%	0.0%	0.0%	

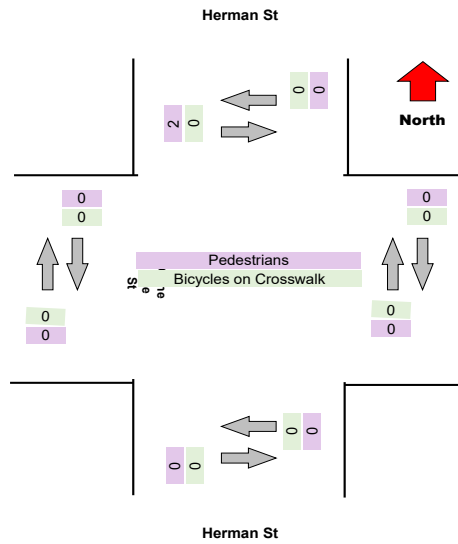
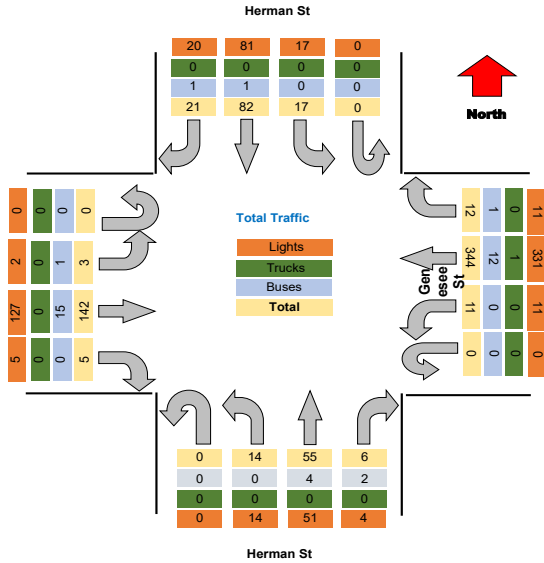

**Turning Movement Peak Hour Data (PM)**

4:30:00 PM

Leg Direction	Herman St				Genesee St				Herman St				Genesee St				Total												
	Southbound				Westbound				Northbound				Eastbound																
	Right	Thru	Left	U-Turn	App Total	Peds CW	Peds CCW	Right	Thru	Left	U-Turn	App Total	Peds CW	Peds CCW	Right	Thru		Left	U-Turn	App Total	Peds CW	Peds CCW							
4:30:00 PM	5	39	9	0	53	0	2	1	57	2	0	60	0	1	11	19	7	0	37	0	0	7	97	2	0	106	0	0	256
4:45:00 PM	4	33	3	0	40	2	1	5	58	4	0	67	0	0	6	23	8	0	37	0	0	3	78	1	0	82	0	0	226
5:00:00 PM	3	35	7	0	45	0	0	3	60	4	0	67	0	0	9	17	9	0	35	0	0	4	72	1	0	77	0	0	224
5:15:00 PM	3	29	5	0	37	0	0	6	47	5	0	58	0	0	6	20	5	0	31	0	0	5	62	3	0	70	0	0	196
<b>Grand Total</b>	15	136	24	0	175	2	3	15	222	15	0	252	0	1	32	79	29	0	140	0	0	19	309	7	0	335	3	0	992
% Approach	8.6%	77.7%	13.7%	0.0%	0.0%	0.0%	0.0%	14.2%	85.8%	0.0%	0.0%	0.0%	0.0%	0.0%	45.1%	41.7%	13.2%	0.0%	0.0%	0.0%	0.0%	0.0%	66.2%	33.8%	0.0%	0.0%	0.0%	0.0%	0.0%
% Total	1.7%	15.1%	2.7%	0.0%	19.4%	0.0%	0.0%	1.7%	24.6%	1.7%	0.0%	27.9%	0.0%	0.0%	3.5%	8.8%	3.2%	0.0%	15.5%	0.0%	0.0%	2.1%	34.3%	0.8%	0.0%	37.1%	0.0%	0.0%	
PHF	0.750	0.872	0.667	0.000	0.825	0.000	0.000	0.625	0.925	0.750	0.000	0.940	0.000	0.000	0.727	0.859	0.806	0.000	0.846	0.000	0.000	0.679	0.796	0.583	0.000	0.790	0.000	0.000	0.881
Lights	15	133	23	0	171	0	0	15	213	14	0	242	0	0	29	79	29	0	137	0	0	17	300	6	0	323	0	0	873
% Lights	100.0%	97.8%	95.8%	0.0%	97.7%	0.0%	0.0%	100.0%	95.9%	93.3%	0.0%	96.0%	0.0%	0.0%	90.6%	100.0%	100.0%	0.0%	97.9%	0.0%	0.0%	89.5%	97.1%	85.7%	0.0%	96.4%	0.0%	0.0%	96.8%
Trucks	0	0	0	0	0	0	0	0	0	0	0	0	0	0	0	0	0	0	0	0	0	0	0	0	0	0	0	0	0
% Trucks	0.0%	0.0%	0.0%	0.0%	0.0%	0.0%	0.0%	0.0%	0.0%	0.0%	0.0%	0.0%	0.0%	0.0%	0.0%	0.0%	0.0%	0.0%	0.0%	0.0%	0.0%	0.0%	0.0%	0.0%	0.0%	0.0%	0.0%	0.0%	0.0%
Buses	0	3	1	0	4	0	0	0	9	1	0	10	0	0	3	0	0	0	3	0	0	2	9	1	0	12	0	0	29
% Buses	0.0%	2.2%	4.2%	0.0%	0.0%	0.0%	0.0%	0.0%	4.1%	6.7%	0.0%	0.0%	0.0%	0.0%	9.4%	0.0%	0.0%	0.0%	0.0%	0.0%	0.0%	10.5%	2.9%	14.3%	0.0%	0.0%	0.0%	0.0%	3.2%
Pedestrians	0	0	0	0	0	2	3	0	0	0	0	0	1	1	0	0	0	0	0	0	0	0	0	0	0	0	0	0	0
% Pedestrians	0.0%	0.0%	0.0%	0.0%	0.0%	100.0%	75.0%	0.0%	0.0%	0.0%	0.0%	0.0%	0.0%	100.0%	0.0%	0.0%	0.0%	0.0%	0.0%	0.0%	0.0%	0.0%	0.0%	0.0%	0.0%	0.0%	0.0%	0.0%	0.0%
Bicycles on Crosswalk	0	0	0	0	0	0	1	0	0	0	0	0	0	0	0	0	0	0	0	0	0	0	0	0	0	0	0	0	0
% Bicycles on Crosswalk	0.0%	0.0%	0.0%	0.0%	0.0%	0.0%	25.0%	0.0%	0.0%	0.0%	0.0%	0.0%	0.0%	0.0%	0.0%	0.0%	0.0%	0.0%	0.0%	0.0%	0.0%	0.0%	0.0%	0.0%	0.0%	0.0%	0.0%	0.0%	0.0%

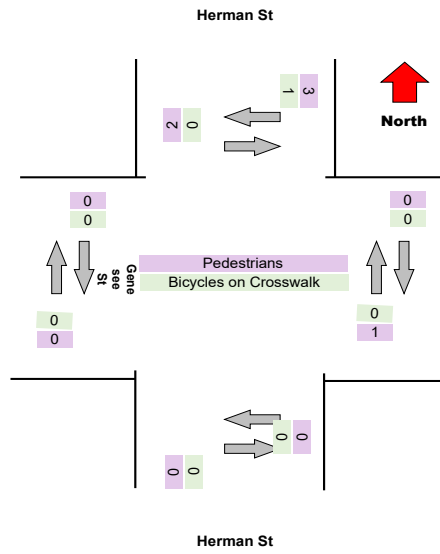
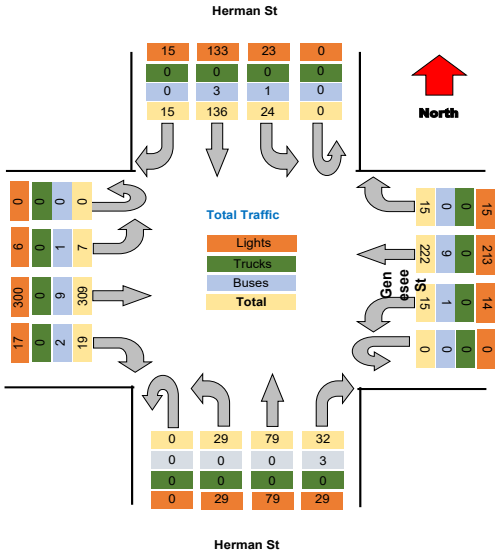



Project : VBH Malta NY  
 Site : Site 4  
 Location : 42.948550, -73.790036  
 Survey Date : 2021-04-28, Wednesday

### Turning Movement Data Plot

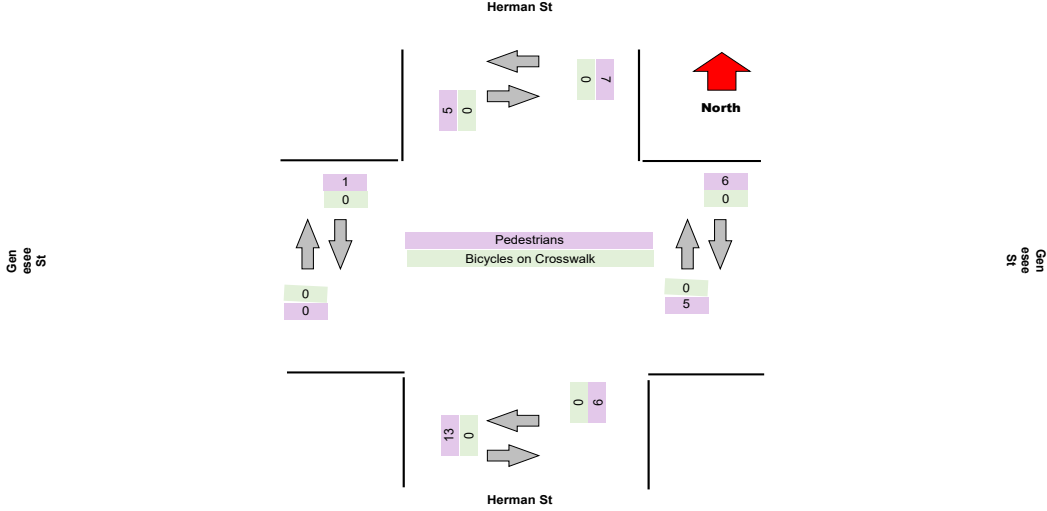
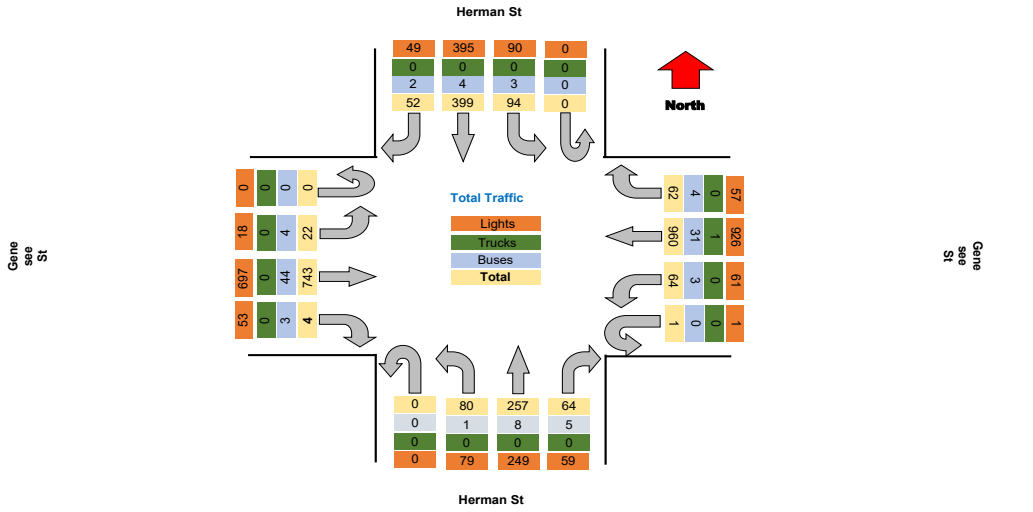

**Turning Movement Peak Hour Data (AM)**

7:30:00 AM

Leg Direction	Herman St Southbound						Genesee St Westbound						Herman St Northbound						Genesee St Eastbound						Total				
	Right	Thru	Left	U-Turn	App Total	Peds CW	Peds CCW	Right	Thru	Left	U-Turn	App Total	Peds CW	Peds CCW	Right	Thru	Left	U-Turn	App Total	Peds CW	Peds CCW	Right	Thru	Left		U-Turn	App Total	Peds CW	Peds CCW
7:30:00 AM	3	16	3	0	22	0	0	5	55	2	0	62	0	0	4	10	1	0	15	0	0	1	26	2	0	29	0	0	128
7:45:00 AM	3	25	4	0	32	0	0	4	99	5	0	108	0	0	3	19	6	0	28	0	0	4	37	0	0	41	0	0	209
8:00:00 AM	2	33	5	0	40	0	0	1	85	4	0	90	0	0	0	18	4	0	22	2	2	1	50	1	0	52	0	0	204
8:15:00 AM	3	21	3	0	27	0	0	4	70	2	0	77	0	0	0	17	4	0	21	0	0	4	36	2	0	42	0	0	167
<b>Grand Total</b>	11	95	15	0	121	0	0	14	309	13	0	337	0	0	7	64	15	0	86	2	2	10	149	5	0	164	0	0	788
% Approach	9.1%	78.5%	12.4%	0.0%	0.0%	0.0%	0.0%	14.2%	85.8%	0.0%	0.0%	0.0%	0.0%	0.0%	45.1%	41.7%	13.2%	0.0%	0.0%	0.0%	0.0%	0.0%	66.2%	33.8%	0.0%	0.0%	0.0%	0.0%	0.0%
% Total	1.6%	13.4%	2.1%	0.0%	17.1%	0.0%	0.0%	2.0%	43.6%	1.8%	0.0%	47.6%	0.0%	0.0%	1.0%	9.0%	2.1%	0.0%	12.1%	0.0%	0.0%	1.4%	21.0%	0.7%	0.0%	23.2%	0.0%	0.0%	0.0%
PHF	0.917	0.720	0.750	0.000	0.756	0.000	0.000	0.700	0.780	0.650	0.000	0.780	0.000	0.000	0.438	0.842	0.625	0.000	0.768	0.000	0.000	0.625	0.745	0.625	0.000	0.788	0.000	0.000	0.847
Lights	11	94	15	0	120	0	0	13	296	13	0	322	0	0	5	60	15	0	80	0	0	9	137	4	0	150	0	0	672
% Lights	100.0%	98.9%	100.0%	0.0%	99.2%	0.0%	0.0%	92.9%	95.8%	100.0%	0.0%	95.5%	0.0%	0.0%	71.4%	93.8%	100.0%	0.0%	93.0%	0.0%	0.0%	90.0%	91.9%	80.0%	0.0%	91.5%	0.0%	0.0%	94.9%
Trucks	0	0	0	0	0	0	0	0	1	0	0	1	0	0	0	0	0	0	0	0	0	0	0	0	0	0	0	0	1
% Trucks	0.0%	0.0%	0.0%	0.0%	0.0%	0.0%	0.0%	0.0%	0.3%	0.0%	0.0%	0.3%	0.0%	0.0%	0.0%	0.0%	0.0%	0.0%	0.0%	0.0%	0.0%	0.0%	0.0%	0.0%	0.0%	0.0%	0.0%	0.0%	0.1%
Buses	0	1	0	0	1	0	0	1	11	0	0	12	0	0	2	4	0	0	6	0	0	1	12	1	0	14	0	0	33
% Buses	0.0%	1.1%	0.0%	0.0%	0.0%	0.0%	0.0%	7.1%	3.6%	0.0%	0.0%	0.0%	0.0%	0.0%	28.6%	6.3%	0.0%	0.0%	0.0%	0.0%	0.0%	10.0%	8.1%	20.0%	0.0%	0.0%	0.0%	4.7%	
Pedestrians	0	0	0	0	0	1	1	0	0	0	0	0	0	0	0	2	3	1	0	0	0	0	0	0	0	0	0	0	0
% Pedestrians	0.0%	0.0%	0.0%	0.0%	0.0%	100.0%	100.0%	0.0%	0.0%	0.0%	0.0%	0.0%	0.0%	0.0%	0.0%	0.0%	0.0%	0.0%	0.0%	0.0%	100.0%	100.0%	0.0%	0.0%	0.0%	0.0%	0.0%	0.0%	0.0%
Bicycles on Crosswalk	0	0	0	0	0	0	0	0	0	0	0	0	0	0	0	0	0	0	0	0	0	0	0	0	0	0	0	0	0
% Bicycles on Crosswalk	0.0%	0.0%	0.0%	0.0%	0.0%	0.0%	0.0%	0.0%	0.0%	0.0%	0.0%	0.0%	0.0%	0.0%	0.0%	0.0%	0.0%	0.0%	0.0%	0.0%	0.0%	0.0%	0.0%	0.0%	0.0%	0.0%	0.0%	0.0%	0.0%

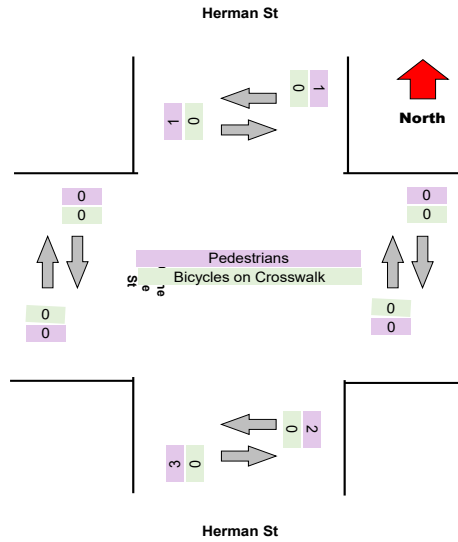
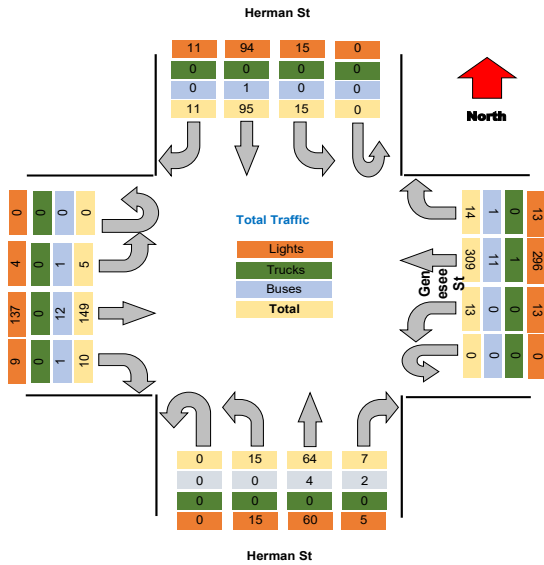



Project : VBH Malta NY  
Site : Site 4  
Location : 42.948550, -73.790036

TSTData.com

Survey Date : 2021-04-28, Wednesday

**Turning Movement Peak Hour Data (PM)**

4:30:00 PM

Leg Direction	Herman St					Genesee St					Herman St					Genesee St					Total					
	Southbound					Westbound					Northbound					Eastbound										
Start Time	Right	Thru	Left	U-Turn	App Total	Peds CW	Peds CCW	Right	Thru	Left	U-Turn	App Total	Peds CW	Peds CCW	Right	Thru	Left	U-Turn	App Total	Peds CW	Peds CCW	Total				
4:30:00 PM	7	43	10	0	60	1	1	8	61	5	0	74	1	1	10	18	8	0	36	1	0	96	0	0	266	
4:45:00 PM	3	36	9	0	48	2	0	5	73	7	0	85	1	2	7	29	6	0	42	1	0	84	0	0	259	
5:00:00 PM	7	26	10	0	43	1	0	4	57	6	1	68	1	1	8	16	6	0	30	5	0	67	0	0	208	
5:15:00 PM	3	27	11	0	41	0	0	5	46	9	0	60	0	0	6	17	8	0	31	0	3	56	0	0	197	
<b>Grand Total</b>	<b>20</b>	<b>132</b>	<b>40</b>	<b>0</b>	<b>192</b>	<b>4</b>	<b>1</b>	<b>22</b>	<b>237</b>	<b>27</b>	<b>1</b>	<b>297</b>	<b>3</b>	<b>4</b>	<b>31</b>	<b>80</b>	<b>28</b>	<b>0</b>	<b>139</b>	<b>7</b>	<b>3</b>	<b>312</b>	<b>0</b>	<b>0</b>	<b>930</b>	
% Approach	10.4%	68.8%	20.8%	0.0%	0.0%	0.0%	0.0%	14.2%	85.8%	0.0%	0.0%	0.0%	0.0%	0.0%	45.1%	41.7%	13.2%	0.0%	0.0%	0.0%	0.0%	0.0%	0.0%	0.0%	0.0%	0.0%
% Total	2.2%	14.2%	4.3%	0.0%	26.6%	0.0%	0.0%	2.4%	25.5%	2.9%	0.1%	30.9%	0.0%	0.0%	3.3%	8.6%	3.0%	0.0%	14.9%	0.0%	0.0%	2.3%	30.4%	0.9%	0.0%	33.5%
PHF	0.714	0.767	0.909	0.000	0.800	0.000	0.000	0.688	0.812	0.750	0.250	0.844	0.000	0.000	0.775	0.690	0.875	0.000	0.827	0.000	0.000	0.750	0.832	0.500	0.000	0.813
Lights	20	130	39	0	189	0	0	22	228	25	1	276	0	0	30	80	28	0	138	0	0	21	268	7	0	296
% Lights	100.0%	98.5%	97.5%	0.0%	98.4%	0.0%	0.0%	100.0%	96.2%	92.6%	100.0%	96.2%	0.0%	0.0%	96.8%	100.0%	100.0%	0.0%	99.3%	0.0%	0.0%	100.0%	94.7%	87.5%	0.0%	94.9%
Trucks	0	0	0	0	0	0	0	0	0	0	0	0	0	0	0	0	0	0	0	0	0	0	0	0	0	0
% Trucks	0.0%	0.0%	0.0%	0.0%	0.0%	0.0%	0.0%	0.0%	0.0%	0.0%	0.0%	0.0%	0.0%	0.0%	0.0%	0.0%	0.0%	0.0%	0.0%	0.0%	0.0%	0.0%	0.0%	0.0%	0.0%	0.0%
Buses	0	2	0	0	2	0	0	0	8	2	0	10	0	0	1	0	0	0	1	0	0	0	14	1	0	15
% Buses	0.0%	1.5%	0.0%	0.0%	0.0%	0.0%	0.0%	0.0%	3.4%	7.4%	0.0%	0.0%	0.0%	0.0%	3.2%	0.0%	0.0%	0.0%	0.0%	0.0%	0.0%	0.0%	4.9%	12.5%	0.0%	0.0%
Pedestrians	0	0	0	0	0	4	3	0	0	0	0	0	3	4	0	0	0	0	0	7	3	0	0	0	0	0
% Pedestrians	0.0%	0.0%	0.0%	0.0%	0.0%	100.0%	100.0%	0.0%	0.0%	0.0%	0.0%	0.0%	100.0%	100.0%	0.0%	0.0%	0.0%	0.0%	0.0%	0.0%	0.0%	0.0%	0.0%	0.0%	0.0%	0.0%
Bicycles on Crosswalk	0	0	0	0	0	0	0	0	0	0	0	0	0	0	0	0	0	0	0	0	0	0	0	0	0	0
% Bicycles on Crosswalk	0.0%	0.0%	0.0%	0.0%	0.0%	0.0%	0.0%	0.0%	0.0%	0.0%	0.0%	0.0%	0.0%	0.0%	0.0%	0.0%	0.0%	0.0%	0.0%	0.0%	0.0%	0.0%	0.0%	0.0%	0.0%	0.0%

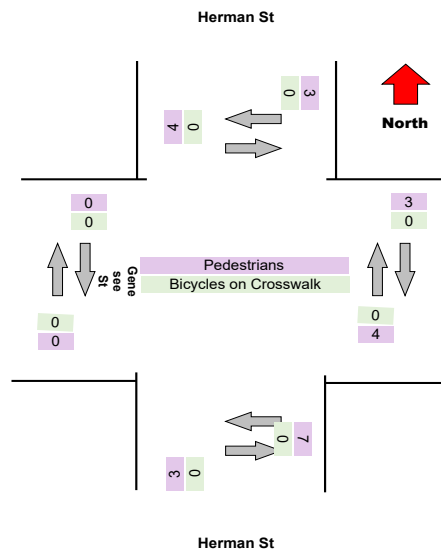
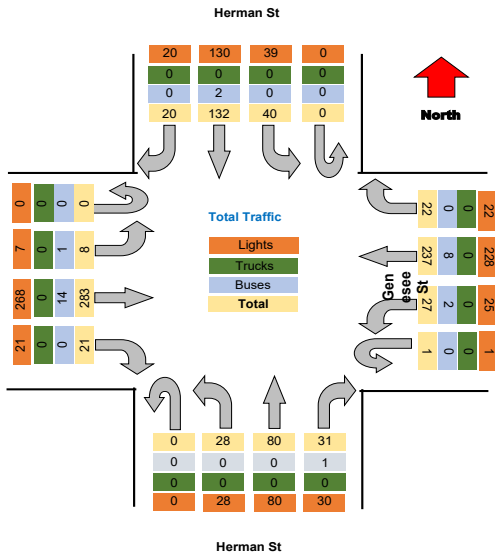



Project : VBH Malta NY  
 Site : Site 4  
 Location : 42.948550, -73.790036  
 Survey Date : 2021-04-28, Wednesday

### Turning Movement Data Plot

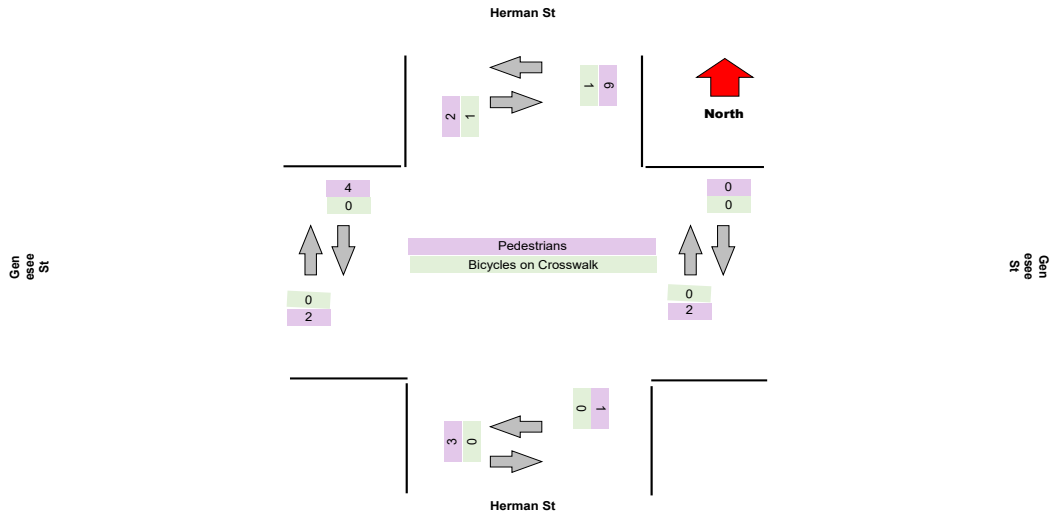
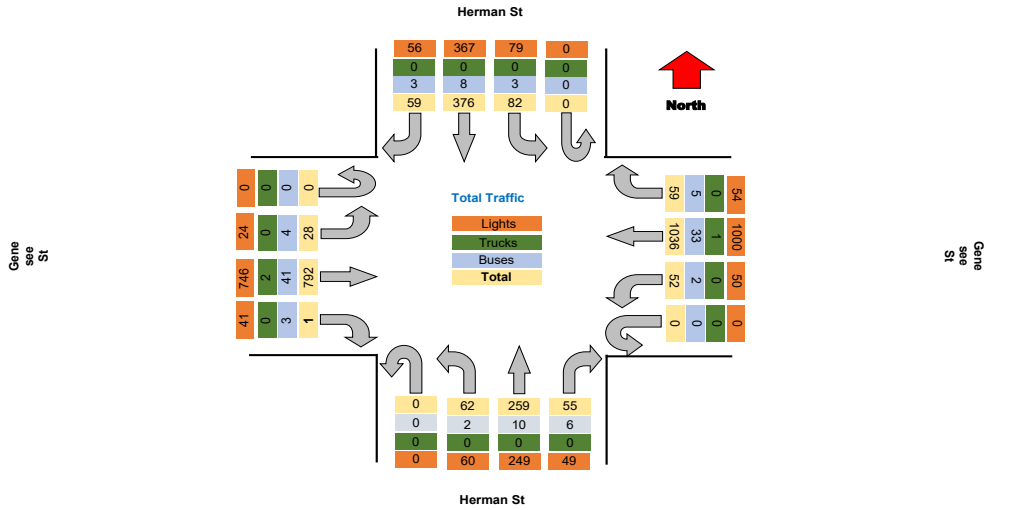

**Turning Movement Peak Hour Data (AM)**

7:30:00 AM

Leg Direction	Herman St						Genesee St						Herman St						Genesee St						Total			
	Southbound			Westbound			Northbound			Eastbound																		
Start Time	Right	Thru	Left	U-Turn	App Total	Peds CW	Peds CCW	Right	Thru	Left	U-Turn	App Total	Peds CW	Peds CCW	Right	Thru	Left	U-Turn	App Total	Peds CW	Peds CCW	Right	Thru	Left	U-Turn	App Total	Peds CW	Peds CCW
7:30:00 AM	1	15	1	0	17	0	0	0	70	1	0	71	0	0	1	7	3	0	11	0	0	1	29	2	0	32	0	0
7:45:00 AM	1	26	5	0	32	0	0	2	103	5	0	110	0	0	2	20	4	0	26	0	0	0	40	1	0	41	0	0
8:00:00 AM	6	20	11	0	37	0	0	3	76	5	0	84	0	0	0	12	6	0	18	0	0	0	60	3	0	63	0	0
8:15:00 AM	2	15	10	0	27	0	0	3	76	1	0	80	0	0	2	11	3	0	16	0	0	2	30	4	0	36	0	0
<b>Grand Total</b>	10	76	27	0	113	0	0	8	325	12	0	345	0	0	5	50	16	0	71	0	0	3	159	10	0	172	0	0
<b>% Approach</b>	8.8%	67.3%	23.9%	0.0%	0.0%	0.0%	0.0%	14.2%	85.8%	0.0%	0.0%	0.0%	0.0%	0.0%	45.1%	41.7%	13.2%	0.0%	0.0%	0.0%	0.0%	0.0%	66.2%	33.8%	0.0%	0.0%	0.0%	0.0%
<b>% Total</b>	1.4%	10.8%	3.9%	0.0%	16.1%	0.0%	0.0%	1.1%	46.4%	1.7%	0.0%	49.2%	0.0%	0.0%	0.7%	7.1%	2.3%	0.0%	10.1%	0.0%	0.0%	0.4%	22.7%	1.4%	0.0%	24.5%	0.0%	0.0%
<b>PHF</b>	0.417	0.731	0.614	0.000	0.764	0.000	0.000	0.667	0.789	0.600	0.000	0.724	0.000	0.000	0.625	0.625	0.667	0.000	0.683	0.000	0.000	0.375	0.663	0.625	0.000	0.683	0.000	0.000
<b>Lights</b>	10	75	27	0	112	0	0	7	312	12	0	331	0	0	3	46	16	0	65	0	0	2	143	9	0	154	0	0
<b>% Lights</b>	100.0%	98.7%	100.0%	0.0%	99.1%	0.0%	0.0%	87.5%	96.0%	100.0%	0.0%	95.9%	0.0%	0.0%	60.0%	92.0%	100.0%	0.0%	91.5%	0.0%	0.0%	66.7%	89.9%	90.0%	0.0%	89.5%	0.0%	0.0%
<b>Trucks</b>	0	0	0	0	0	0	0	0	1	0	0	1	0	0	0	0	0	0	0	0	0	0	2	0	0	2	0	0
<b>% Trucks</b>	0.0%	0.0%	0.0%	0.0%	0.0%	0.0%	0.0%	0.0%	0.3%	0.0%	0.0%	0.3%	0.0%	0.0%	0.0%	0.0%	0.0%	0.0%	0.0%	0.0%	0.0%	0.0%	1.3%	0.0%	0.0%	1.2%	0.0%	0.0%
<b>Buses</b>	0	1	0	0	1	0	0	1	12	0	0	13	0	0	2	4	0	0	6	0	0	1	14	1	0	16	0	0
<b>% Buses</b>	0.0%	1.3%	0.0%	0.0%	0.0%	0.0%	0.0%	12.5%	3.7%	0.0%	0.0%	0.0%	0.0%	0.0%	40.0%	8.0%	0.0%	0.0%	0.0%	0.0%	0.0%	33.3%	8.8%	10.0%	0.0%	0.0%	0.0%	
<b>Pedestrians</b>	0	0	0	0	0	0	0	0	0	0	0	0	0	0	0	0	0	0	0	0	0	0	0	0	0	0	0	0
<b>% Pedestrians</b>	0.0%	0.0%	0.0%	0.0%	0.0%	0.0%	0.0%	0.0%	0.0%	0.0%	0.0%	0.0%	0.0%	0.0%	0.0%	0.0%	0.0%	0.0%	0.0%	0.0%	0.0%	0.0%	0.0%	0.0%	0.0%	0.0%	0.0%	0.0%
<b>Bicycles on Crosswalk</b>	0	0	0	0	0	0	0	0	0	0	0	0	0	0	0	0	0	0	0	0	0	0	0	0	0	0	0	0
<b>% Bicycles on Crosswalk</b>	0.0%	0.0%	0.0%	0.0%	0.0%	0.0%	0.0%	0.0%	0.0%	0.0%	0.0%	0.0%	0.0%	0.0%	0.0%	0.0%	0.0%	0.0%	0.0%	0.0%	0.0%	0.0%	0.0%	0.0%	0.0%	0.0%	0.0%	0.0%

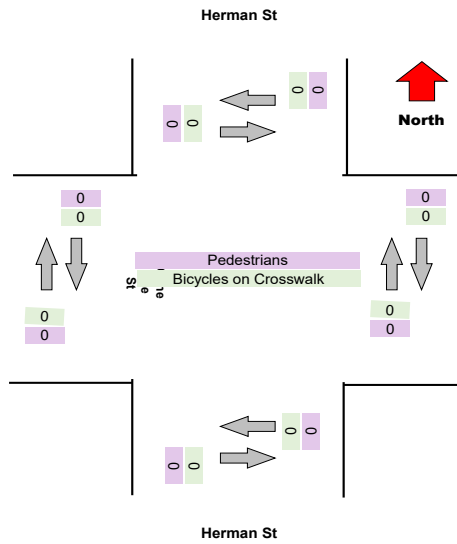
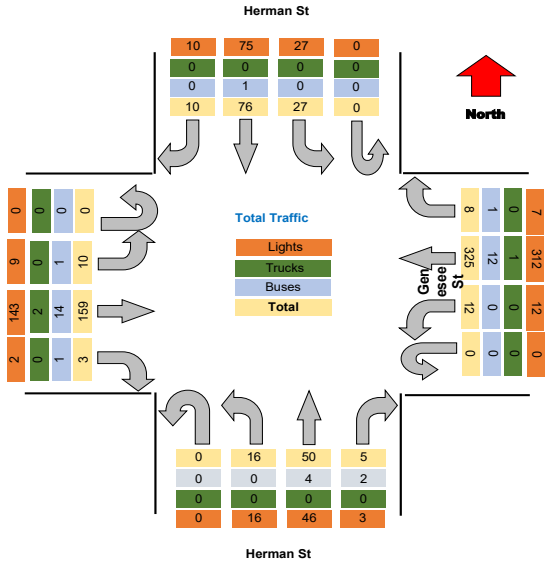

Project : VBH Malta NY  
Site : Site 4  
Location : 42.948550, -73.790036  
Survey Date : 2021-04-28, Wednesday

TSTData.com

**Turning Movement Peak Hour Data (PM)**

4:30:00 PM

Leg Direction	Herman St				Genesee St				Herman St				Genesee St				Total						
	Southbound				Westbound				Northbound				Eastbound										
Start Time	Right	Thru	Left	U-Turn	App Total	Peds CW	Peds CCW	Right	Thru	Left	U-Turn	App Total	Peds CW	Peds CCW	Right	Thru	Left	U-Turn	App Total	Peds CW	Peds CCW	Total	
4:30:00 PM	7	30	10	0	47	0	0	6	85	3	0	94	0	0	9	28	4	0	41	0	0	284	
4:45:00 PM	2	35	11	0	48	0	1	8	62	2	0	72	0	0	3	19	9	0	31	0	0	216	
5:00:00 PM	0	25	5	0	30	0	0	5	67	10	0	82	0	0	3	26	3	0	32	0	0	216	
5:15:00 PM	8	30	4	0	42	1	0	3	84	5	0	92	0	1	5	18	3	0	26	0	1	243	
<b>Grand Total</b>	<b>17</b>	<b>120</b>	<b>30</b>	<b>0</b>	<b>167</b>	<b>1</b>	<b>0</b>	<b>22</b>	<b>298</b>	<b>20</b>	<b>0</b>	<b>340</b>	<b>0</b>	<b>1</b>	<b>20</b>	<b>91</b>	<b>19</b>	<b>0</b>	<b>130</b>	<b>0</b>	<b>0</b>	<b>957</b>	
% Approach	10.2%	71.9%	18.0%	0.0%	0.0%	0.0%	0.0%	14.2%	85.8%	0.0%	0.0%	0.0%	0.0%	0.0%	45.1%	41.7%	13.2%	0.0%	0.0%	0.0%	0.0%	0.0%	0.0%
% Total	1.8%	12.5%	3.1%	0.0%	17.5%	0.0%	0.0%	2.3%	31.1%	2.1%	0.0%	35.5%	0.0%	0.0%	2.1%	9.5%	2.0%	0.0%	13.6%	0.0%	0.0%	2.4%	30.0%
PHF	0.531	0.857	0.682	0.000	0.870	0.000	0.000	0.688	0.876	0.500	0.000	0.904	0.000	0.000	0.556	0.813	0.528	0.000	0.793	0.000	0.000	0.639	0.788
Lights	17	114	29	0	160	0	0	21	287	19	0	327	0	0	17	90	17	0	124	0	0	916	
% Lights	100.0%	95.0%	96.7%	0.0%	95.8%	0.0%	0.0%	95.5%	96.3%	95.0%	0.0%	96.2%	0.0%	0.0%	85.0%	98.0%	89.5%	0.0%	95.4%	0.0%	0.0%	95.7%	
Trucks	0	0	0	0	0	0	0	0	0	0	0	0	0	0	0	0	0	0	0	0	0	0	
% Trucks	0.0%	0.0%	0.0%	0.0%	0.0%	0.0%	0.0%	0.0%	0.0%	0.0%	0.0%	0.0%	0.0%	0.0%	0.0%	0.0%	0.0%	0.0%	0.0%	0.0%	0.0%	0.0%	
Buses	0	5	1	0	6	0	0	1	10	1	0	12	0	0	3	1	2	0	6	0	0	37	
% Buses	0.0%	4.2%	3.3%	0.0%	0.0%	0.0%	0.0%	4.5%	3.4%	5.0%	0.0%	0.0%	0.0%	0.0%	15.0%	1.1%	10.5%	0.0%	0.0%	0.0%	0.0%	3.9%	
Pedestrians	0	0	0	0	0	1	0	0	0	0	0	0	1	0	0	0	0	0	0	3	0	0	
% Pedestrians	0.0%	0.0%	0.0%	0.0%	0.0%	100.0%	0.0%	0.0%	0.0%	0.0%	0.0%	0.0%	100.0%	0.0%	0.0%	0.0%	0.0%	0.0%	0.0%	0.0%	100.0%	0.0%	
Bicycles on Crosswalk	0	0	0	0	0	1	0	0	0	0	0	0	0	0	0	0	0	0	0	0	0	0	
% Bicycles on Crosswalk	0.0%	0.0%	0.0%	0.0%	0.0%	100.0%	0.0%	0.0%	0.0%	0.0%	0.0%	0.0%	0.0%	0.0%	0.0%	0.0%	0.0%	0.0%	0.0%	0.0%	0.0%	0.0%	

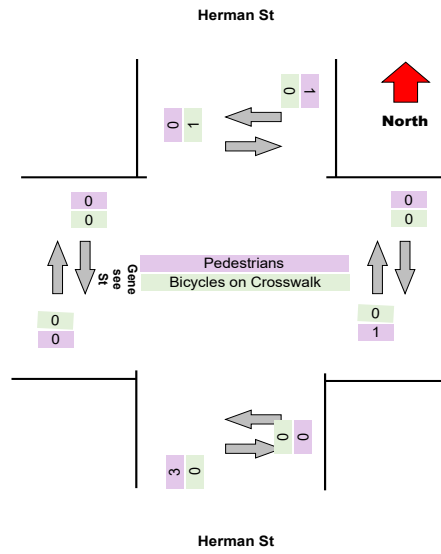
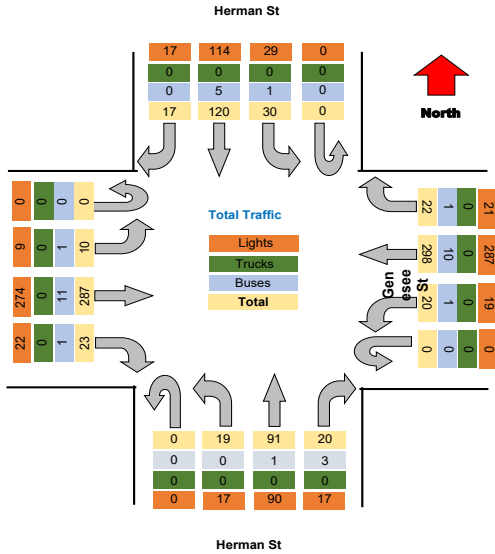



### Turning Movement Data Plot

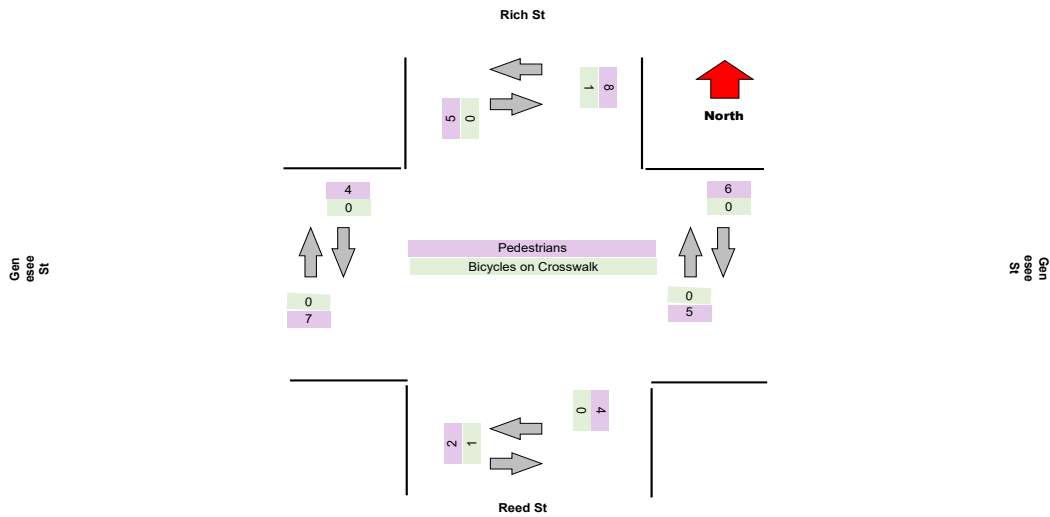
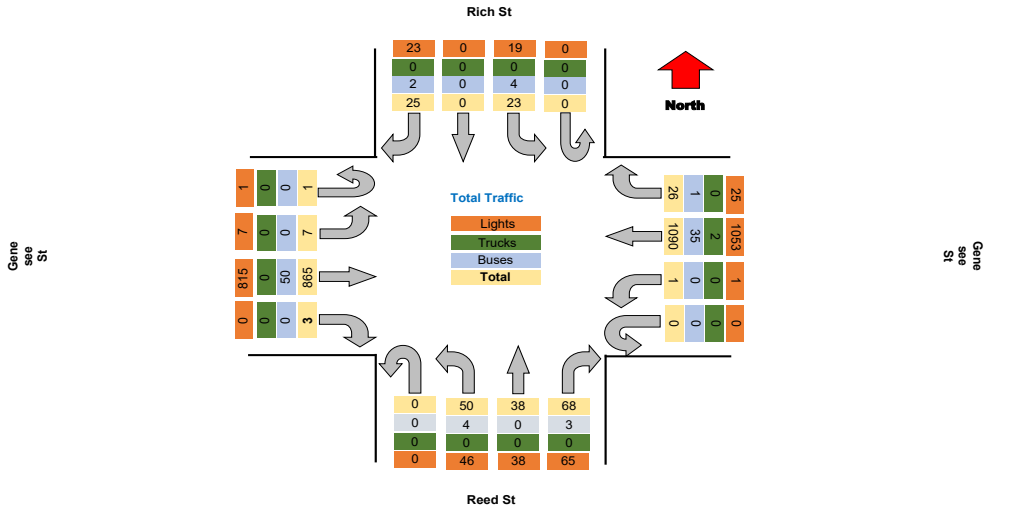

### Turning Movement Peak Hour Data (AM)

7:30:00 AM

Leg Direction	Rich St						Genesee St						Reed St						Genesee St						Total				
	Southbound			Northbound			Westbound			Eastbound			Northbound			Eastbound													
Start Time	Right	Thru	Left	U-Turn	App Total	Peds CW	Peds CCW	Right	Thru	Left	U-Turn	App Total	Peds CW	Peds CCW	Right	Thru	Left	U-Turn	App Total	Peds CW	Peds CCW	Right	Thru	Left	U-Turn	App Total	Peds CW	Peds CCW	
7:30:00 AM	0	0	1	0	1	1	0	2	79	0	0	81	0	0	3	2	6	0	11	0	0	0	23	0	0	23	3	2	116
7:45:00 AM	0	0	1	0	1	1	0	2	100	0	0	102	2	0	2	0	0	0	4	0	0	0	45	0	0	45	0	0	162
8:00:00 AM	2	0	1	0	3	1	0	0	106	0	0	106	0	0	8	0	4	0	12	0	0	0	62	0	0	62	2	0	183
8:15:00 AM	1	0	2	0	3	1	0	3	83	0	0	87	0	0	1	1	2	0	4	0	0	0	38	1	0	39	2	0	133
<b>Grand Total</b>	<b>3</b>	<b>0</b>	<b>5</b>	<b>0</b>	<b>8</b>	<b>3</b>	<b>0</b>	<b>7</b>	<b>368</b>	<b>0</b>	<b>0</b>	<b>378</b>	<b>2</b>	<b>0</b>	<b>14</b>	<b>3</b>	<b>12</b>	<b>0</b>	<b>31</b>	<b>0</b>	<b>0</b>	<b>0</b>	<b>168</b>	<b>1</b>	<b>0</b>	<b>169</b>	<b>3</b>	<b>2</b>	<b>684</b>
% Approach	37.5%	0.0%	62.5%	0.0%	0.0%	0.0%	0.0%	14.2%	85.8%	0.0%	0.0%	0.0%	0.0%	0.0%	45.1%	41.7%	13.2%	0.0%	0.0%	0.0%	0.0%	0.0%	66.2%	33.8%	0.0%	0.0%	0.0%	0.0%	0.0%
% Total	0.5%	0.0%	0.9%	0.0%	1.4%	0.0%	0.0%	1.2%	63.0%	0.0%	0.0%	64.4%	0.0%	0.0%	2.4%	0.5%	2.1%	0.0%	5.3%	0.0%	0.0%	0.0%	28.8%	0.2%	0.0%	28.9%	0.0%	0.0%	0.0%
PHF	0.375	0.000	0.625	0.000	0.667	0.000	0.000	0.583	0.868	0.000	0.000	0.887	0.000	0.000	0.438	0.375	0.500	0.000	0.646	0.000	0.000	0.000	0.677	0.250	0.000	0.681	0.000	0.000	0.798
Lights	3	0	3	0	6	0	0	7	357	0	0	364	0	0	14	3	10	0	27	0	0	0	150	1	0	151	0	0	548
% Lights	100.0%	0.0%	60.0%	0.0%	75.0%	0.0%	0.0%	100.0%	97.0%	0.0%	0.0%	96.8%	0.0%	0.0%	100.0%	100.0%	83.3%	0.0%	87.1%	0.0%	0.0%	0.0%	89.3%	100.0%	0.0%	89.3%	0.0%	0.0%	93.8%
Trucks	0	0	0	0	0	0	0	0	1	0	0	1	0	0	0	0	0	0	0	0	0	0	0	0	0	0	0	0	1
% Trucks	0.0%	0.0%	0.0%	0.0%	0.0%	0.0%	0.0%	0.0%	0.3%	0.0%	0.0%	0.3%	0.0%	0.0%	0.0%	0.0%	0.0%	0.0%	0.0%	0.0%	0.0%	0.0%	0.0%	0.0%	0.0%	0.0%	0.0%	0.0%	0.2%
Buses	0	0	2	0	2	0	0	0	10	0	0	10	0	0	0	0	2	0	2	0	0	0	18	0	0	18	0	0	32
% Buses	0.0%	0.0%	40.0%	0.0%	0.0%	0.0%	0.0%	0.0%	2.7%	0.0%	0.0%	0.0%	0.0%	0.0%	0.0%	0.0%	16.7%	0.0%	0.0%	0.0%	0.0%	0.0%	10.7%	0.0%	0.0%	0.0%	0.0%	0.0%	5.5%
Pedestrians	0	0	0	0	0	3	1	0	0	0	0	0	2	0	0	0	0	0	0	0	0	0	0	0	0	0	5	2	0
% Pedestrians	0.0%	0.0%	0.0%	0.0%	0.0%	100.0%	100.0%	0.0%	0.0%	0.0%	0.0%	0.0%	100.0%	0.0%	0.0%	0.0%	0.0%	0.0%	0.0%	0.0%	0.0%	0.0%	0.0%	0.0%	0.0%	0.0%	100.0%	100.0%	0.0%
Bicycles on Crosswalk	0	0	0	0	0	0	0	0	0	0	0	0	0	0	0	0	0	0	0	0	0	0	0	0	0	0	0	0	0
% Bicycles on Crosswalk	0.0%	0.0%	0.0%	0.0%	0.0%	0.0%	0.0%	0.0%	0.0%	0.0%	0.0%	0.0%	0.0%	0.0%	0.0%	0.0%	0.0%	0.0%	0.0%	0.0%	0.0%	0.0%	0.0%	0.0%	0.0%	0.0%	0.0%	0.0%	0.0%

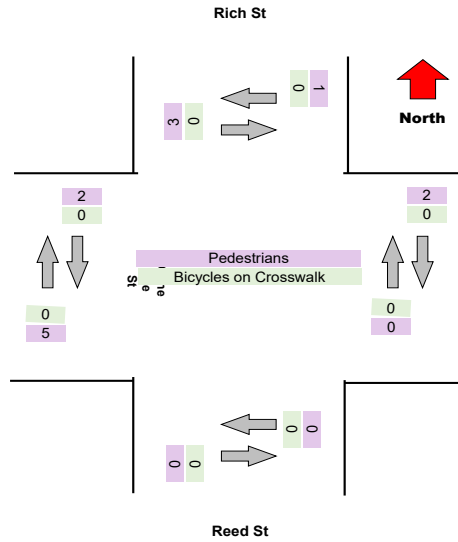
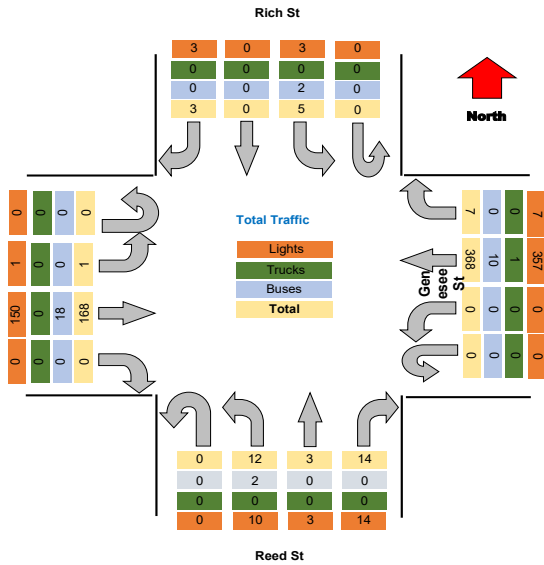



### Turning Movement Peak Hour Data (PM)

4:30:00 PM

Leg Direction	Rich St				Genesee St				Reed St				Genesee St				Total													
	Southbound				Westbound				Northbound				Eastbound																	
Start Time	Right	Thru	Left	U-Turn	App Total	Peds CW	Peds CCW	Right	Thru	Left	U-Turn	App Total	Peds CW	Peds CCW	Right	Thru	Left	U-Turn	App Total	Peds CW	Peds CCW									
4:30:00 PM	2	0	6	0	8	0	1	2	54	0	0	56	0	1	4	4	3	0	11	2	0	0	103	0	0	178				
4:45:00 PM	3	0	0	0	3	0	0	2	77	0	0	79	0	0	8	4	3	0	15	0	0	0	86	1	0	87	0	0	184	
5:00:00 PM	0	0	1	0	1	1	0	2	69	0	0	71	0	0	7	2	6	0	15	0	0	0	85	0	0	85	0	0	172	
5:15:00 PM	5	0	2	0	7	0	0	1	61	1	0	63	0	0	6	6	2	0	14	0	1	0	67	0	0	67	0	0	151	
<b>Grand Total</b>	<b>10</b>	<b>0</b>	<b>9</b>	<b>0</b>	<b>19</b>	<b>1</b>	<b>0</b>	<b>7</b>	<b>251</b>	<b>1</b>	<b>0</b>	<b>259</b>	<b>0</b>	<b>1</b>	<b>25</b>	<b>16</b>	<b>14</b>	<b>0</b>	<b>55</b>	<b>2</b>	<b>1</b>	<b>0</b>	<b>341</b>	<b>1</b>	<b>0</b>	<b>342</b>	<b>0</b>	<b>0</b>	<b>685</b>	
% Approach	52.6%	0.0%	47.4%	0.0%	0.0%	0.0%	0.0%	14.2%	85.8%	0.0%	0.0%	0.0%	0.0%	0.0%	45.1%	41.7%	13.2%	0.0%	0.0%	0.0%	0.0%	0.0%	0.0%	66.2%	33.8%	0.0%	0.0%	0.0%	0.0%	0.0%
% Total	1.5%	0.0%	1.3%	0.0%	2.8%	0.0%	0.0%	1.0%	38.1%	0.1%	0.0%	39.3%	0.0%	0.0%	3.6%	2.3%	2.0%	0.0%	8.0%	0.0%	0.0%	0.0%	0.0%	49.8%	0.1%	0.0%	49.9%	0.0%	0.0%	0.0%
PHF	0.500	0.000	0.375	0.000	0.594	0.000	0.000	0.875	0.847	0.250	0.000	0.851	0.000	0.000	0.781	0.667	0.583	0.000	0.917	0.000	0.000	0.000	0.000	0.828	0.250	0.000	0.830	0.000	0.000	0.931
Lights	8	0	8	0	16	0	0	7	251	1	0	259	0	0	24	16	14	0	54	0	0	0	328	1	0	329	0	0	658	
% Lights	80.0%	0.0%	88.9%	0.0%	84.2%	0.0%	0.0%	100.0%	96.2%	100.0%	0.0%	96.3%	0.0%	0.0%	96.0%	100.0%	100.0%	0.0%	98.2%	0.0%	0.0%	0.0%	0.0%	96.2%	100.0%	0.0%	96.2%	0.0%	0.0%	96.1%
Trucks	0	0	0	0	0	0	0	0	0	0	0	0	0	0	0	0	0	0	0	0	0	0	0	0	0	0	0	0	0	0
% Trucks	0.0%	0.0%	0.0%	0.0%	0.0%	0.0%	0.0%	0.0%	0.0%	0.0%	0.0%	0.0%	0.0%	0.0%	0.0%	0.0%	0.0%	0.0%	0.0%	0.0%	0.0%	0.0%	0.0%	0.0%	0.0%	0.0%	0.0%	0.0%	0.0%	0.0%
Buses	2	0	1	0	3	0	0	0	10	0	0	10	0	0	1	0	0	0	1	0	0	0	13	0	0	13	0	0	27	
% Buses	20.0%	0.0%	11.1%	0.0%	0.0%	0.0%	0.0%	0.0%	3.8%	0.0%	0.0%	0.0%	0.0%	0.0%	4.0%	0.0%	0.0%	0.0%	0.0%	0.0%	0.0%	0.0%	3.8%	0.0%	0.0%	0.0%	0.0%	0.0%	3.9%	
Pedestrians	0	0	0	0	0	1	3	0	0	0	0	0	1	0	0	0	0	0	2	1	0	0	0	0	0	0	0	0	0	
% Pedestrians	0.0%	0.0%	0.0%	0.0%	0.0%	100.0%	75.0%	0.0%	0.0%	0.0%	0.0%	0.0%	100.0%	100.0%	0.0%	0.0%	0.0%	0.0%	0.0%	100.0%	100.0%	0.0%	0.0%	0.0%	0.0%	0.0%	0.0%	0.0%	0.0%	
Bicycles on Crosswalk	0	0	0	0	0	1	0	0	0	0	0	0	0	0	0	0	0	0	0	0	0	0	0	0	0	0	0	0	0	
% Bicycles on Crosswalk	0.0%	0.0%	0.0%	0.0%	0.0%	0.0%	25.0%	0.0%	0.0%	0.0%	0.0%	0.0%	0.0%	0.0%	0.0%	0.0%	0.0%	0.0%	0.0%	0.0%	0.0%	0.0%	0.0%	0.0%	0.0%	0.0%	0.0%	0.0%	0.0%	

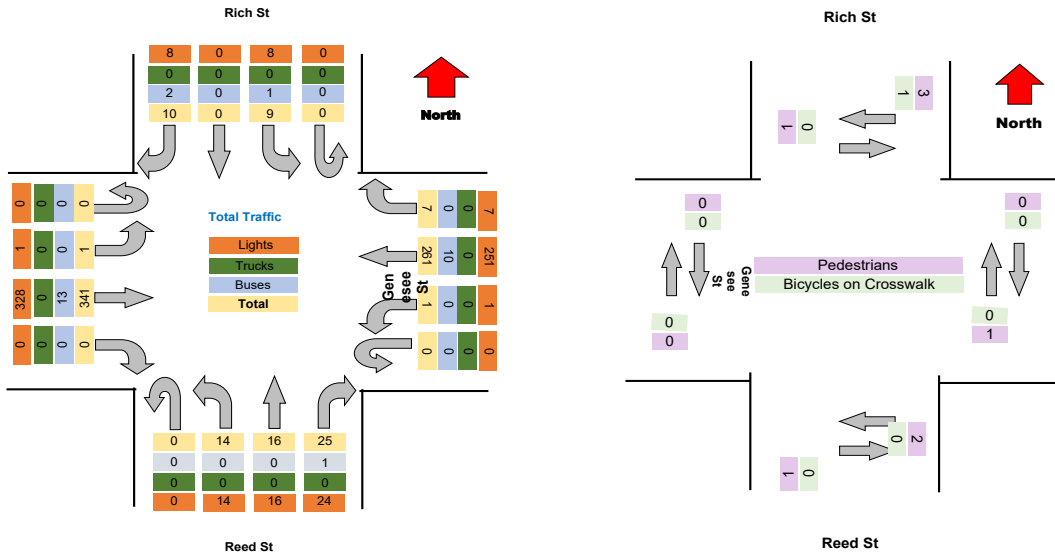



Project : VBH Malta NY  
 Site : Site 4  
 Location : 42.948550, -73.790036  
 Survey Date : 2021-04-28, Wednesday

### Turning Movement Data Plot

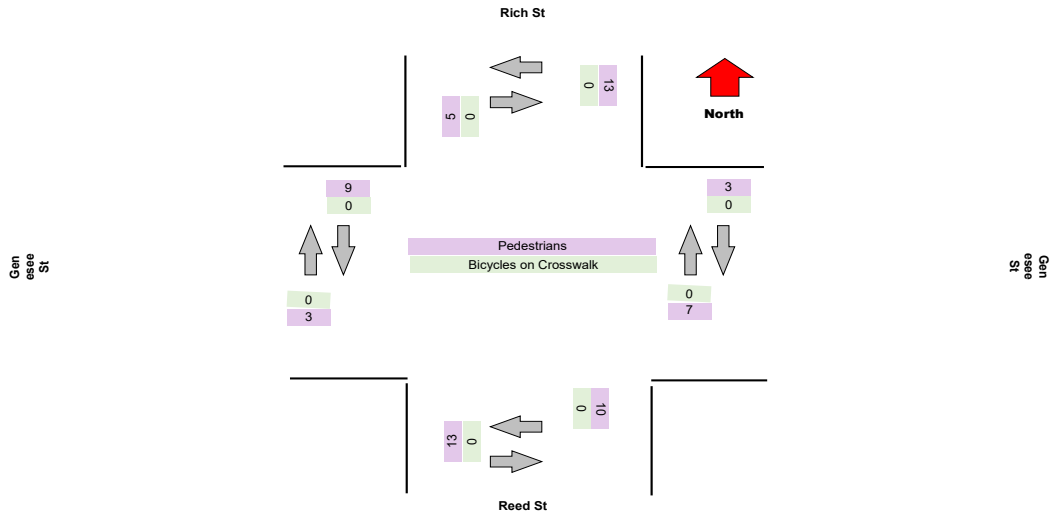
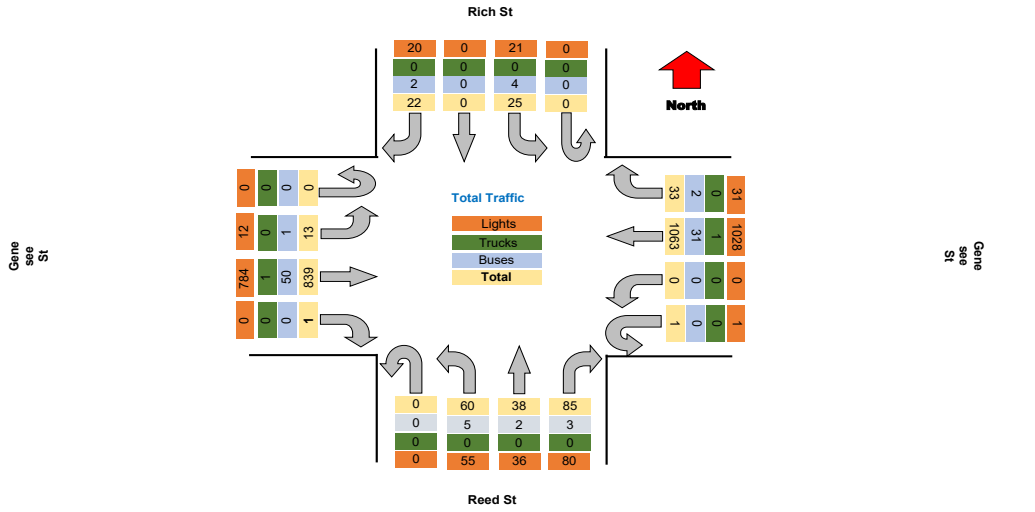

Project : VBH Malta NY  
Site : Site 4  
Location : 42.948550, -73.790036

TSTData.com

Survey Date : 2021-04-28, Wednesday

**Turning Movement Peak Hour Data (AM)**

7:30:00 AM

Leg Direction	Rich St						Genesee St						Reed St						Genesee St						Total				
	Southbound			Westbound			Northbound			Eastbound			Northbound			Eastbound													
Start Time	Right	Thru	Left	U-Turn	App Total	Peds CW	Peds CCW	Right	Thru	Left	U-Turn	App Total	Peds CW	Peds CCW	Right	Thru	Left	U-Turn	App Total	Peds CW	Peds CCW	Right	Thru	Left	U-Turn	App Total	Peds CW	Peds CCW	
7:30:00 AM	1	0	0	0	1	0	0	2	56	0	0	58	0	0	1	2	5	0	8	1	0	0	31	0	0	31	0	0	
7:45:00 AM	2	0	3	0	5	0	0	3	104	0	0	107	1	1	3	0	3	0	6	0	0	0	47	1	0	48	1	0	
8:00:00 AM	0	0	1	0	1	0	0	1	101	0	0	104	0	0	5	2	1	0	8	0	2	0	50	0	0	50	0	0	
8:15:00 AM	0	0	2	0	2	1	0	3	64	0	0	67	0	0	0	2	6	0	8	0	1	0	38	1	0	39	0	0	
<b>Grand Total</b>	<b>3</b>	<b>0</b>	<b>6</b>	<b>0</b>	<b>9</b>	<b>1</b>	<b>0</b>	<b>9</b>	<b>325</b>	<b>0</b>	<b>0</b>	<b>336</b>	<b>1</b>	<b>1</b>	<b>9</b>	<b>9</b>	<b>15</b>	<b>0</b>	<b>32</b>	<b>1</b>	<b>3</b>	<b>0</b>	<b>155</b>	<b>2</b>	<b>0</b>	<b>157</b>	<b>1</b>	<b>0</b>	
% Approach	33.3%	0.0%	66.7%	0.0%	0.0%	0.0%	0.0%	14.2%	85.8%	0.0%	0.0%	0.0%	0.0%	0.0%	45.1%	41.7%	13.2%	0.0%	0.0%	0.0%	0.0%	0.0%	66.2%	33.8%	0.0%	0.0%	0.0%	0.0%	
% Total	0.6%	0.0%	1.1%	0.0%	1.7%	0.0%	0.0%	1.7%	59.6%	0.0%	0.0%	61.7%	0.0%	0.0%	1.7%	1.1%	2.8%	0.0%	5.9%	0.0%	0.0%	0.0%	30.5%	0.4%	0.0%	30.8%	0.0%	0.0%	
PHF	0.375	0.000	0.500	0.000	0.450	0.000	0.000	0.750	0.781	0.000	0.000	0.785	0.000	0.000	0.450	0.750	0.625	0.000	1.000	0.000	0.000	0.000	0.830	0.500	0.000	0.840	0.000	0.000	
Lights	3	0	5	0	8	0	0	9	314	0	0	323	0	0	9	5	12	0	26	0	0	0	150	2	0	152	0	0	
% Lights	100.0%	0.0%	83.3%	0.0%	88.9%	0.0%	0.0%	100.0%	96.6%	0.0%	0.0%	96.1%	0.0%	0.0%	100.0%	83.3%	80.0%	0.0%	81.3%	0.0%	0.0%	0.0%	90.4%	100.0%	0.0%	90.5%	0.0%	0.0%	
Trucks	0	0	0	0	0	0	0	0	1	0	0	1	0	0	0	0	0	0	0	0	0	0	1	0	0	1	0	0	
% Trucks	0.0%	0.0%	0.0%	0.0%	0.0%	0.0%	0.0%	0.0%	0.3%	0.0%	0.0%	0.3%	0.0%	0.0%	0.0%	0.0%	0.0%	0.0%	0.0%	0.0%	0.0%	0.0%	0.6%	0.0%	0.0%	0.6%	0.0%	0.0%	
Buses	0	0	1	0	1	0	0	0	9	0	0	9	0	0	0	1	3	0	4	0	0	0	15	0	0	15	0	0	
% Buses	0.0%	0.0%	16.7%	0.0%	0.0%	0.0%	0.0%	0.0%	2.8%	0.0%	0.0%	0.0%	0.0%	0.0%	0.0%	16.7%	20.0%	0.0%	0.0%	0.0%	0.0%	0.0%	9.0%	0.0%	0.0%	0.0%	0.0%	0.0%	
Pedestrians	0	0	0	0	0	1	2	0	0	0	0	0	1	1	0	0	0	0	0	1	3	0	0	0	0	0	1	0	
% Pedestrians	0.0%	0.0%	0.0%	0.0%	0.0%	100.0%	100.0%	0.0%	0.0%	0.0%	0.0%	0.0%	100.0%	100.0%	0.0%	0.0%	0.0%	0.0%	0.0%	0.0%	100.0%	100.0%	0.0%	0.0%	0.0%	0.0%	0.0%	100.0%	0.0%
Bicycles on Crosswalk	0	0	0	0	0	0	0	0	0	0	0	0	0	0	0	0	0	0	0	0	0	0	0	0	0	0	0	0	
% Bicycles on Crosswalk	0.0%	0.0%	0.0%	0.0%	0.0%	0.0%	0.0%	0.0%	0.0%	0.0%	0.0%	0.0%	0.0%	0.0%	0.0%	0.0%	0.0%	0.0%	0.0%	0.0%	0.0%	0.0%	0.0%	0.0%	0.0%	0.0%	0.0%	0.0%	

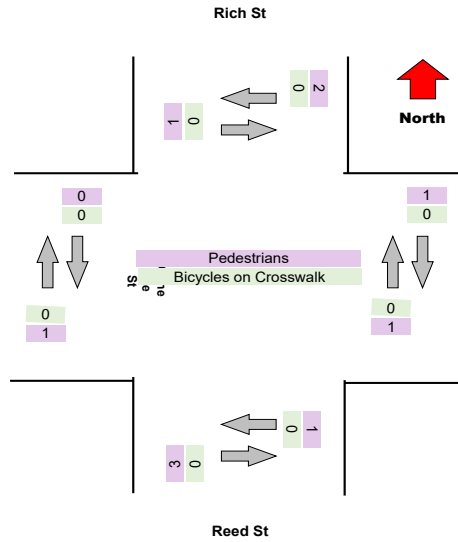
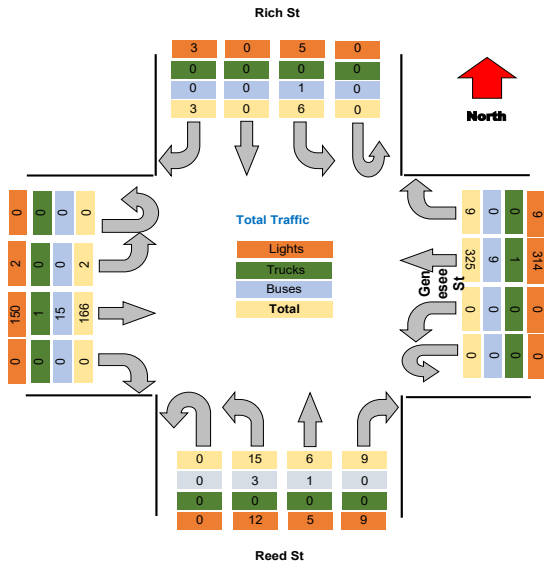

**Turning Movement Peak Hour Data (PM)**

4:30:00 PM

Leg Direction	Rich St				Genesee St				Reed St				Genesee St				Total									
	Southbound				Westbound				Northbound				Eastbound													
Start Time	Right	Thru	Left	U-Turn	App Total	Peds CW	Peds CCW	Right	Thru	Left	U-Turn	App Total	Peds CW	Peds CCW	Right	Thru	Left	U-Turn	App Total	Peds CW	Peds CCW					
4:30:00 PM	3	0	4	0	7	1	1	3	81	0	1	85	0	0	9	7	1	0	17	0	0	92	1	1	202	
4:45:00 PM	5	0	3	0	8	2	1	3	73	0	0	76	0	0	8	1	8	0	17	1	0	0	84	1	0	186
5:00:00 PM	1	0	3	0	4	1	0	3	60	0	0	63	0	0	7	7	6	0	20	1	0	0	77	2	0	166
5:15:00 PM	2	0	1	0	3	0	0	2	61	0	0	63	0	0	8	0	2	0	10	0	0	0	65	1	0	142
<b>Grand Total</b>	<b>11</b>	<b>0</b>	<b>11</b>	<b>0</b>	<b>22</b>	<b>4</b>	<b>2</b>	<b>11</b>	<b>275</b>	<b>0</b>	<b>1</b>	<b>287</b>	<b>0</b>	<b>0</b>	<b>32</b>	<b>15</b>	<b>17</b>	<b>0</b>	<b>64</b>	<b>2</b>	<b>0</b>	<b>0</b>	<b>319</b>	<b>5</b>	<b>0</b>	<b>696</b>
% Approach	50.0%	0.0%	50.0%	0.0%	0.0%	0.0%	0.0%	14.2%	85.8%	0.0%	0.0%	0.0%	0.0%	0.0%	45.1%	41.7%	13.2%	0.0%	0.0%	0.0%	0.0%	0.0%	66.2%	33.8%	0.0%	0.0%
% Total	1.6%	0.0%	1.6%	0.0%	3.2%	0.0%	0.0%	1.6%	39.5%	0.0%	0.1%	41.2%	0.0%	0.0%	4.6%	2.2%	2.4%	0.0%	8.2%	0.0%	0.0%	0.0%	45.7%	0.7%	0.0%	46.4%
PHF	0.550	0.000	0.688	0.000	0.688	0.000	0.000	0.917	0.849	0.000	0.250	0.844	0.000	0.000	0.889	0.536	0.531	0.000	0.800	0.000	0.000	0.000	0.864	0.625	0.000	0.868
Lights	9	0	10	0	19	0	0	11	265	0	1	277	0	0	30	14	17	0	61	0	0	0	300	5	0	662
% Lights	81.8%	0.0%	90.9%	0.0%	86.4%	0.0%	0.0%	100.0%	96.4%	0.0%	100.0%	96.5%	0.0%	0.0%	93.8%	93.3%	100.0%	0.0%	95.3%	0.0%	0.0%	0.0%	94.3%	100.0%	0.0%	94.4%
Trucks	0	0	0	0	0	0	0	0	0	0	0	0	0	0	0	0	0	0	0	0	0	0	0	0	0	0
% Trucks	0.0%	0.0%	0.0%	0.0%	0.0%	0.0%	0.0%	0.0%	0.0%	0.0%	0.0%	0.0%	0.0%	0.0%	0.0%	0.0%	0.0%	0.0%	0.0%	0.0%	0.0%	0.0%	0.0%	0.0%	0.0%	0.0%
Buses	2	0	1	0	3	0	0	0	9	0	0	9	0	0	2	1	0	0	3	0	0	0	15	0	0	30
% Buses	18.2%	0.0%	9.1%	0.0%	0.0%	0.0%	0.0%	0.0%	3.3%	0.0%	0.0%	0.0%	0.0%	0.0%	6.3%	6.7%	0.0%	0.0%	0.0%	0.0%	0.0%	0.0%	4.7%	0.0%	0.0%	0.0%
Pedestrians	0	0	0	0	0	4	2	0	0	0	0	0	0	0	0	0	0	0	0	2	0	0	0	0	0	5
% Pedestrians	0.0%	0.0%	0.0%	0.0%	0.0%	100.0%	100.0%	0.0%	0.0%	0.0%	0.0%	0.0%	0.0%	0.0%	0.0%	0.0%	0.0%	0.0%	0.0%	0.0%	100.0%	0.0%	0.0%	0.0%	0.0%	100.0%
Bicycles on Crosswalk	0	0	0	0	0	0	0	0	0	0	0	0	0	0	0	0	0	0	0	0	0	0	0	0	0	0
% Bicycles on Crosswalk	0.0%	0.0%	0.0%	0.0%	0.0%	0.0%	0.0%	0.0%	0.0%	0.0%	0.0%	0.0%	0.0%	0.0%	0.0%	0.0%	0.0%	0.0%	0.0%	0.0%	0.0%	0.0%	0.0%	0.0%	0.0%	0.0%

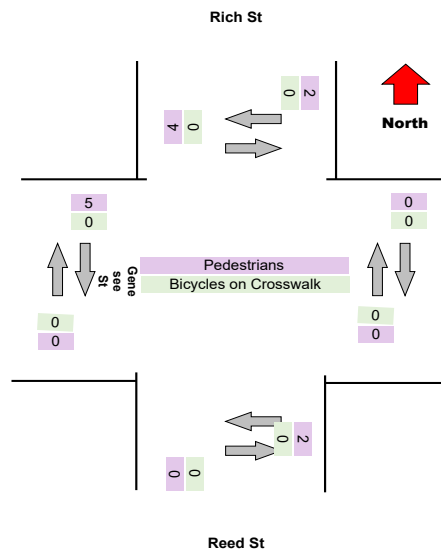
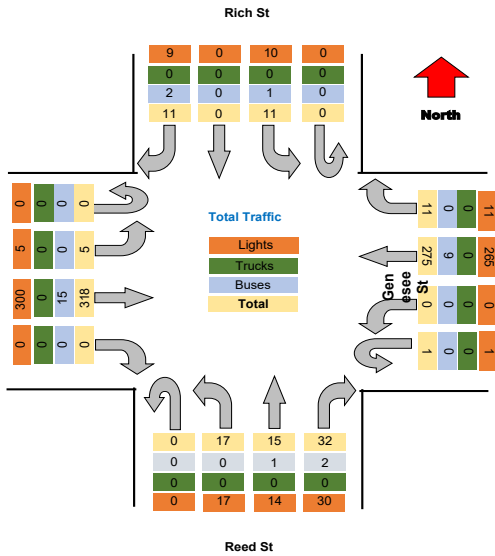



Project : VBH Malta NY  
 Site : Site 4  
 Location : 42.948550, -73.790036  
 Survey Date : 2021-04-28, Wednesday

### Turning Movement Data Plot

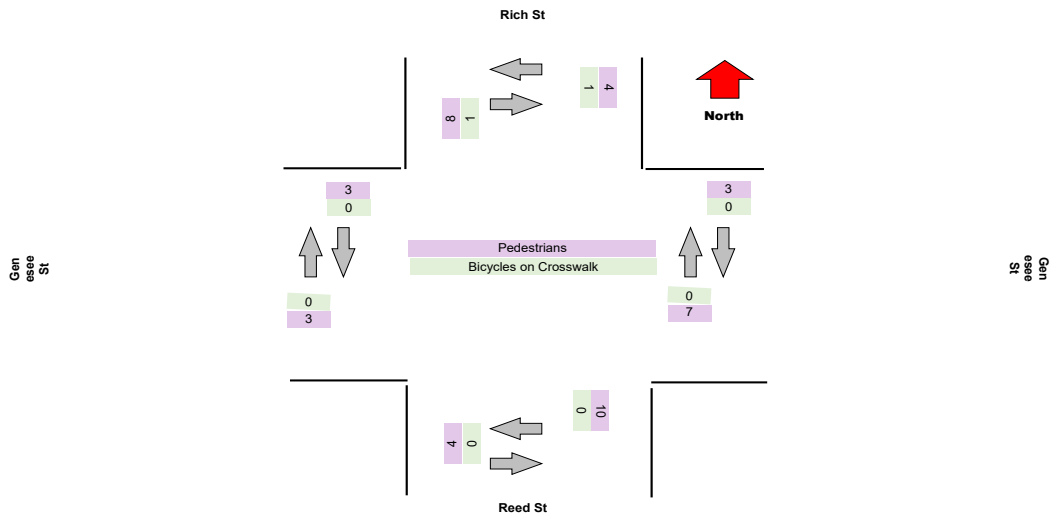
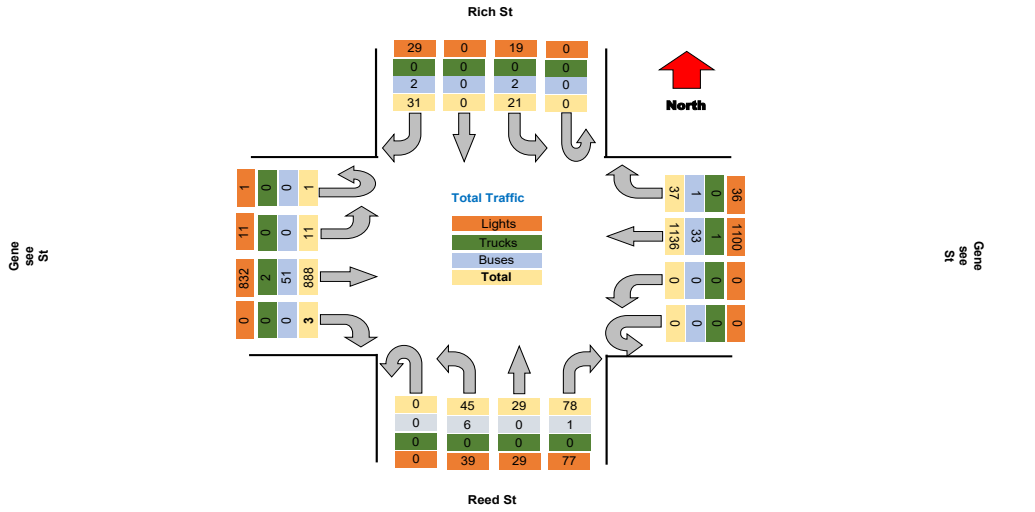

Project : VBH Malta NY  
Site : Site 4  
Location : 42.948550, -73.790036

TSTData.com

Survey Date : 2021-04-28, Wednesday

### Turning Movement Peak Hour Data (AM)

7:30:00 AM

Leg Direction	Rich St						Genesee St						Reed St						Genesee St						Total			
	Southbound			Northbound			Westbound			Eastbound			Northbound			Eastbound												
Start Time	Right	Thru	Left	U-Turn	App Total	Peds CW	Peds CCW	Right	Thru	Left	U-Turn	App Total	Peds CW	Peds CCW	Right	Thru	Left	U-Turn	App Total	Peds CW	Peds CCW	Right	Thru	Left	U-Turn	App Total	Peds CW	Peds CCW
7:30:00 AM	1	0	1	0	2	0	0	3	68	0	0	71	0	0	3	1	2	0	6	0	0	0	33	0	0	33	0	0
7:45:00 AM	0	0	2	0	2	0	0	3	105	0	0	108	1	1	0	0	5	0	7	0	1	0	41	0	0	41	0	0
8:00:00 AM	2	0	0	0	2	0	0	2	86	0	0	88	0	0	3	0	0	0	3	1	0	0	69	1	0	70	0	0
8:15:00 AM	1	0	1	0	2	0	0	1	84	0	0	85	0	0	2	2	2	0	6	0	0	0	43	1	0	44	0	0
<b>Grand Total</b>	<b>4</b>	<b>0</b>	<b>4</b>	<b>0</b>	<b>8</b>	<b>0</b>	<b>0</b>	<b>9</b>	<b>343</b>	<b>0</b>	<b>0</b>	<b>352</b>	<b>1</b>	<b>1</b>	<b>8</b>	<b>3</b>	<b>9</b>	<b>0</b>	<b>22</b>	<b>1</b>	<b>1</b>	<b>0</b>	<b>185</b>	<b>2</b>	<b>0</b>	<b>188</b>	<b>3</b>	<b>0</b>
% Approach	50.0%	0.0%	50.0%	0.0%	0.0%	0.0%	0.0%	14.2%	85.8%	0.0%	0.0%	0.0%	0.0%	0.0%	45.1%	41.7%	13.2%	0.0%	0.0%	0.0%	0.0%	0.0%	66.2%	33.8%	0.0%	0.0%	0.0%	0.0%
% Total	0.7%	0.0%	0.7%	0.0%	1.4%	0.0%	0.0%	1.6%	60.2%	0.0%	0.0%	61.8%	0.0%	0.0%	1.4%	0.5%	1.6%	0.0%	3.9%	0.0%	0.0%	0.0%	32.6%	0.4%	0.0%	33.0%	0.0%	0.0%
PHF	0.500	0.000	0.500	0.000	1.000	0.000	0.000	0.750	0.817	0.000	0.000	0.815	0.000	0.000	0.667	0.375	0.450	0.000	0.786	0.000	0.000	0.000	0.674	0.500	0.000	0.671	0.000	0.000
Lights	4	0	3	0	7	0	0	9	332	0	0	341	0	0	8	3	6	0	17	0	0	0	167	2	0	169	0	0
% Lights	100.0%	0.0%	75.0%	0.0%	87.5%	0.0%	0.0%	100.0%	96.8%	0.0%	0.0%	96.9%	0.0%	0.0%	100.0%	100.0%	66.7%	0.0%	77.3%	0.0%	0.0%	0.0%	89.8%	100.0%	0.0%	89.9%	0.0%	0.0%
Trucks	0	0	0	0	0	0	0	0	1	0	0	1	0	0	0	0	0	0	0	0	0	0	2	0	0	2	0	0
% Trucks	0.0%	0.0%	0.0%	0.0%	0.0%	0.0%	0.0%	0.0%	0.3%	0.0%	0.0%	0.3%	0.0%	0.0%	0.0%	0.0%	0.0%	0.0%	0.0%	0.0%	0.0%	0.0%	1.1%	0.0%	0.0%	1.1%	0.0%	0.0%
Buses	0	0	1	0	1	0	0	0	10	0	0	10	0	0	0	0	3	0	3	0	0	0	17	0	0	17	0	0
% Buses	0.0%	0.0%	25.0%	0.0%	0.0%	0.0%	0.0%	0.0%	2.9%	0.0%	0.0%	0.0%	0.0%	0.0%	0.0%	0.0%	33.3%	0.0%	0.0%	0.0%	0.0%	9.1%	0.0%	0.0%	0.0%	0.0%	0.0%	
Pedestrians	0	0	0	0	0	0	0	0	0	0	0	1	1	1	0	0	0	0	1	1	1	0	0	0	0	0	0	0
% Pedestrians	0.0%	0.0%	0.0%	0.0%	0.0%	0.0%	0.0%	0.0%	0.0%	0.0%	0.0%	0.0%	100.0%	100.0%	0.0%	0.0%	0.0%	0.0%	0.0%	100.0%	100.0%	0.0%	0.0%	0.0%	0.0%	0.0%	0.0%	0.0%
Bicycles on Crosswalk	0	0	0	0	0	0	0	0	0	0	0	0	0	0	0	0	0	0	0	0	0	0	0	0	0	0	0	0
% Bicycles on Crosswalk	0.0%	0.0%	0.0%	0.0%	0.0%	0.0%	0.0%	0.0%	0.0%	0.0%	0.0%	0.0%	0.0%	0.0%	0.0%	0.0%	0.0%	0.0%	0.0%	0.0%	0.0%	0.0%	0.0%	0.0%	0.0%	0.0%	0.0%	0.0%

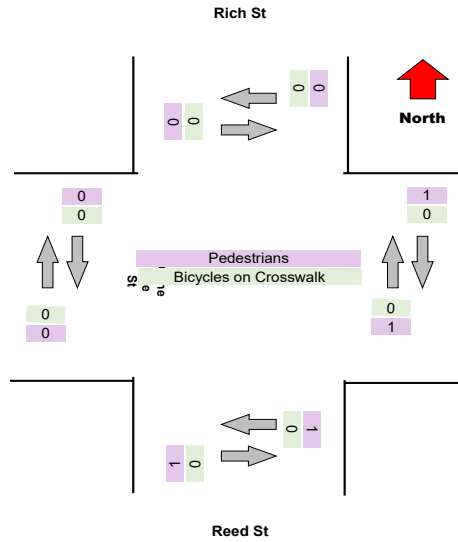
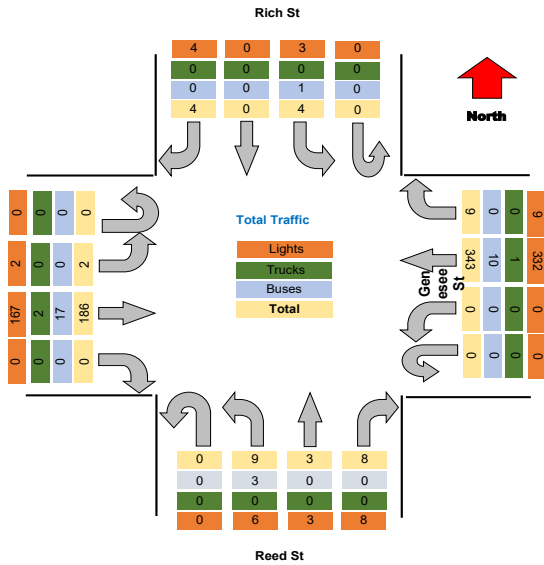



### Turning Movement Peak Hour Data (PM)

4:30:00 PM

Leg Direction	Rich St					Genesee St					Reed St					Genesee St					Total									
	Southbound					Westbound					Northbound					Eastbound														
Start Time	Right	Thru	Left	U-Turn	App Total	Peds CW	Peds CCW	Right	Thru	Left	U-Turn	App Total	Peds CW	Peds CCW	Right	Thru	Left	U-Turn	App Total	Peds CW	Peds CCW	Right	Thru	Left	U-Turn	App Total	Peds CW	Peds CCW		
4:30:00 PM	5	0	5	0	10	1	0	4	85	0	0	89	0	0	6	6	5	0	17	1	2	0	98	0	0	98	0	0	214	
4:45:00 PM	2	0	2	0	4	0	0	3	75	0	0	78	0	0	5	1	2	0	8	2	0	0	74	0	0	74	0	0	164	
5:00:00 PM	3	0	2	0	5	2	0	4	87	0	0	91	0	0	5	2	4	0	11	0	0	0	65	3	0	68	0	0	175	
5:15:00 PM	2	0	1	0	3	3	0	2	85	0	0	87	0	0	5	3	4	0	13	2	1	0	80	0	0	80	1	1	183	
Grand Total	12	0	10	0	22	6	0	13	332	0	0	345	0	0	22	12	15	0	49	3	3	0	317	3	0	320	1	1	738	
% Approach	54.5%	0.0%	45.5%	0.0%	0.0%	0.0%	0.0%	14.2%	85.8%	0.0%	0.0%	0.0%	0.0%	0.0%	45.1%	41.7%	13.2%	0.0%	0.0%	0.0%	0.0%	0.0%	66.2%	33.8%	0.0%	0.0%	0.0%	0.0%	0.0%	
% Total	1.6%	0.0%	1.4%	0.0%	3.0%	0.0%	0.0%	1.8%	45.1%	0.0%	0.0%	46.9%	0.0%	0.0%	3.0%	1.6%	2.0%	0.0%	6.7%	0.0%	0.0%	0.0%	43.1%	0.4%	0.0%	43.5%	0.0%	0.0%	0.0%	
PHF	0.600	0.000	0.500	0.000	0.550	0.000	0.000	0.813	0.954	0.000	0.000	0.948	0.000	0.000	0.917	0.500	0.750	0.000	0.721	0.000	0.000	0.000	0.809	0.250	0.000	0.816	0.000	0.000	0.860	
Lights	10	0	10	0	20	0	0	13	321	0	0	334	0	0	22	12	15	0	49	0	0	0	300	3	0	303	0	0	706	
% Lights	83.3%	0.0%	100.0%	0.0%	90.9%	0.0%	0.0%	100.0%	96.7%	0.0%	0.0%	96.8%	0.0%	0.0%	100.0%	100.0%	100.0%	0.0%	100.0%	0.0%	0.0%	0.0%	94.6%	100.0%	0.0%	94.7%	0.0%	0.0%	95.9%	
Trucks	0	0	0	0	0	0	0	0	0	0	0	0	0	0	0	0	0	0	0	0	0	0	0	0	0	0	0	0	0	
% Trucks	0.0%	0.0%	0.0%	0.0%	0.0%	0.0%	0.0%	0.0%	0.0%	0.0%	0.0%	0.0%	0.0%	0.0%	0.0%	0.0%	0.0%	0.0%	0.0%	0.0%	0.0%	0.0%	0.0%	0.0%	0.0%	0.0%	0.0%	0.0%	0.0%	
Buses	2	0	0	0	2	0	0	0	10	0	0	10	0	0	0	0	0	0	0	0	0	0	15	0	0	15	0	0	27	
% Buses	16.7%	0.0%	0.0%	0.0%	0.0%	0.0%	0.0%	0.0%	3.0%	0.0%	0.0%	0.0%	0.0%	0.0%	0.0%	0.0%	0.0%	0.0%	0.0%	0.0%	0.0%	0.0%	4.7%	0.0%	0.0%	0.0%	0.0%	0.0%	3.7%	
Pedestrians	0	0	0	0	0	5	2	0	0	0	0	0	0	0	0	0	0	0	5	3	0	0	0	0	0	0	1	1	0	
% Pedestrians	0.0%	0.0%	0.0%	0.0%	0.0%	83.3%	100.0%	0.0%	0.0%	0.0%	0.0%	0.0%	0.0%	0.0%	0.0%	0.0%	0.0%	0.0%	0.0%	100.0%	100.0%	0.0%	0.0%	0.0%	0.0%	0.0%	0.0%	100.0%	100.0%	0.0%
Bicycles on Crosswalk	0	0	0	0	0	1	0	0	0	0	0	0	0	0	0	0	0	0	0	0	0	0	0	0	0	0	0	0	0	
% Bicycles on Crosswalk	0.0%	0.0%	0.0%	0.0%	0.0%	16.7%	0.0%	0.0%	0.0%	0.0%	0.0%	0.0%	0.0%	0.0%	0.0%	0.0%	0.0%	0.0%	0.0%	0.0%	0.0%	0.0%	0.0%	0.0%	0.0%	0.0%	0.0%	0.0%	0.0%	

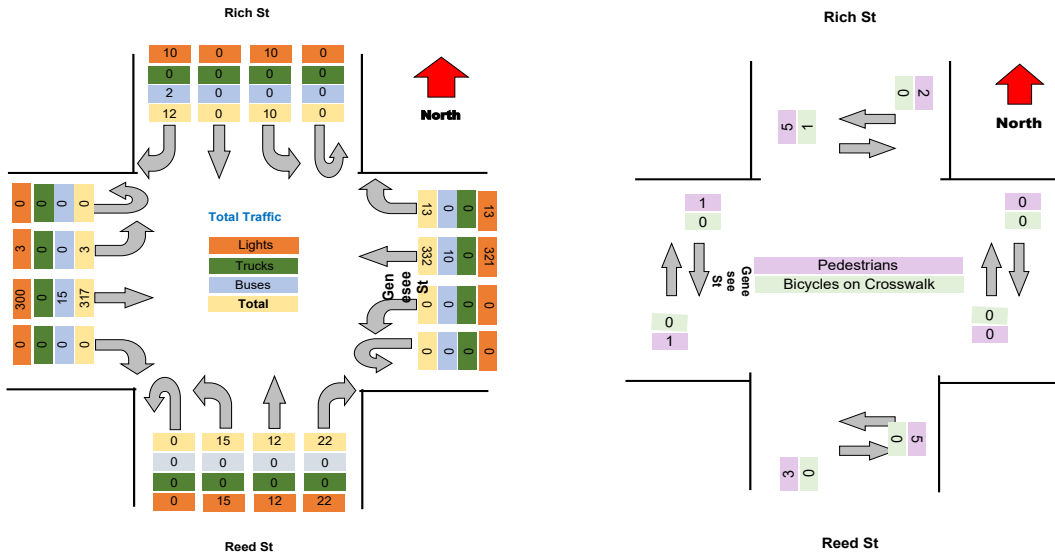



Project : VBH Malta NY  
 Site : Site 4  
 Location : 42.948550, -73.790036  
 Survey Date : 2021-04-28, Wednesday

### Turning Movement Data Plot

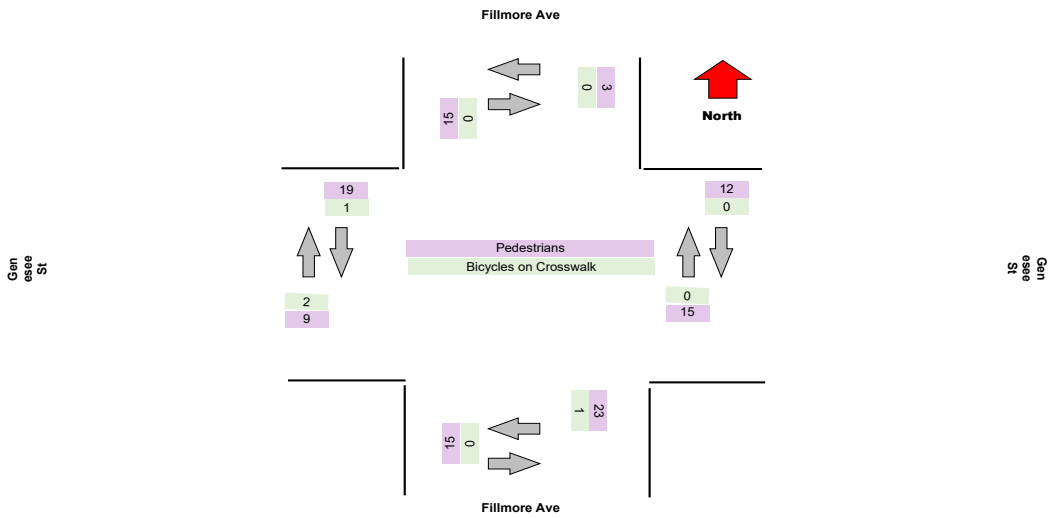
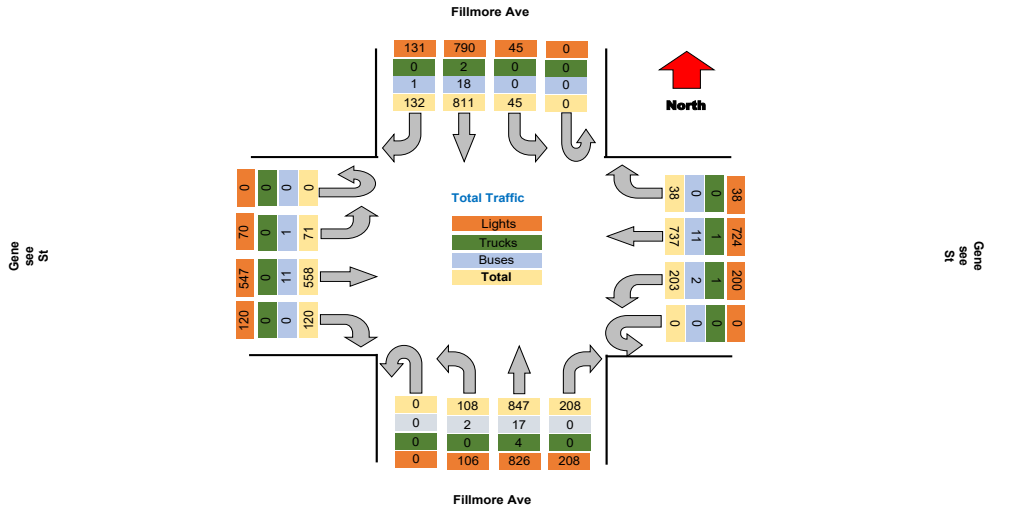

Turning Movement Peak Hour Data (AM)

7:30:00 AM

Leg Direction	Fillmore Ave						Genesee St						Fillmore Ave						Genesee St						Total					
	Southbound			Northbound			Westbound			Eastbound			Northbound			Eastbound														
Start Time	Right	Thru	Left	U-Turn	App Total	Peds CW	Peds CCW	Right	Thru	Left	U-Turn	App Total	Peds CW	Peds CCW	Right	Thru	Left	U-Turn	App Total	Peds CW	Peds CCW	Right	Thru	Left	U-Turn	App Total	Peds CW	Peds CCW		
7:30:00 AM	2	46	1	0	49	0	0	2	46	7	0	55	1	0	6	31	5	0	43	0	0	2	13	2	0	17	0	0	164	
7:45:00 AM	5	50	0	0	55	2	0	1	48	10	0	59	1	0	13	42	6	0	62	0	0	5	22	2	0	29	0	0	206	
8:00:00 AM	4	45	1	0	50	1	0	3	45	11	0	59	2	0	8	33	7	0	50	1	0	13	21	5	0	39	0	1	198	
8:15:00 AM	9	60	1	0	70	0	0	0	44	5	0	50	0	0	6	32	5	0	43	3	1	5	23	2	0	30	0	0	193	
<b>Grand Total</b>	<b>20</b>	<b>201</b>	<b>3</b>	<b>0</b>	<b>224</b>	<b>3</b>	<b>0</b>	<b>6</b>	<b>183</b>	<b>33</b>	<b>0</b>	<b>223</b>	<b>4</b>	<b>0</b>	<b>33</b>	<b>138</b>	<b>23</b>	<b>0</b>	<b>198</b>	<b>4</b>	<b>1</b>	<b>25</b>	<b>79</b>	<b>11</b>	<b>0</b>	<b>115</b>	<b>3</b>	<b>1</b>	<b>780</b>	
% Approach	8.9%	89.7%	1.3%	0.0%	0.0%	0.0%	0.0%	2.7%	82.1%	14.8%	0.0%	0.0%	0.0%	0.0%	16.7%	69.7%	11.6%	0.0%	0.0%	0.0%	0.0%	21.7%	65.7%	9.8%	0.0%	0.0%	0.0%	0.0%	0.0%	
% Total	2.6%	26.4%	0.4%	0.0%	28.6%	0.0%	0.0%	0.8%	24.1%	4.3%	0.0%	29.3%	0.0%	0.0%	4.3%	18.2%	3.0%	0.0%	26.1%	0.0%	0.0%	3.3%	10.4%	1.4%	0.0%	15.1%	0.0%	0.0%	0.0%	
PHF	0.556	0.838	0.750	0.000	0.800	0.000	0.000	0.500	0.953	0.750	0.000	0.945	0.000	0.000	0.635	0.821	0.821	0.000	0.798	0.000	0.000	0.481	0.859	0.550	0.000	0.737	0.000	0.000	0.927	
Lights	20	194	3	0	217	0	0	6	181	32	0	219	0	0	33	129	22	0	184	0	0	25	75	10	0	110	0	0	730	
% Lights	100.0%	96.5%	100.0%	0.0%	96.9%	0.0%	0.0%	100.0%	98.9%	97.0%	0.0%	98.2%	0.0%	0.0%	100.0%	93.5%	95.7%	0.0%	92.9%	0.0%	0.0%	100.0%	94.9%	90.9%	0.0%	95.7%	0.0%	0.0%	96.1%	
Trucks	0	0	0	0	0	0	0	0	1	1	0	2	0	0	0	2	0	0	2	0	0	0	0	0	0	0	0	0	4	
% Trucks	0.0%	0.0%	0.0%	0.0%	0.0%	0.0%	0.0%	0.0%	0.5%	3.0%	0.0%	0.9%	0.0%	0.0%	0.0%	1.4%	0.0%	0.0%	1.0%	0.0%	0.0%	0.0%	0.0%	0.0%	0.0%	0.0%	0.0%	0.0%	0.5%	
Buses	0	6	0	0	6	0	0	0	1	0	0	1	0	0	0	7	1	0	8	0	0	0	4	1	0	5	0	0	20	
% Buses	0.0%	3.0%	0.0%	0.0%	0.0%	0.0%	0.0%	0.0%	0.5%	0.0%	0.0%	0.0%	0.0%	0.0%	0.0%	5.1%	4.3%	0.0%	0.0%	0.0%	0.0%	0.0%	5.1%	9.1%	0.0%	0.0%	0.0%	0.0%	2.6%	
Pedestrians	0	0	0	0	0	3	1	0	0	0	0	4	0	0	0	0	0	0	4	1	0	0	0	0	0	0	0	1	0	
% Pedestrians	0.0%	0.0%	0.0%	0.0%	0.0%	100.0%	100.0%	0.0%	0.0%	0.0%	0.0%	0.0%	100.0%	0.0%	0.0%	0.0%	0.0%	0.0%	0.0%	0.0%	100.0%	100.0%	0.0%	0.0%	0.0%	0.0%	0.0%	0.0%	100.0%	0.0%
Bicycles on Crosswalk	0	0	0	0	0	0	0	0	0	0	0	0	0	0	0	0	0	0	0	0	0	0	0	0	0	0	0	0	0	
% Bicycles on Crosswalk	0.0%	0.0%	0.0%	0.0%	0.0%	0.0%	0.0%	0.0%	0.0%	0.0%	0.0%	0.0%	0.0%	0.0%	0.0%	0.0%	0.0%	0.0%	0.0%	0.0%	0.0%	0.0%	0.0%	0.0%	0.0%	0.0%	0.0%	0.0%	0.0%	

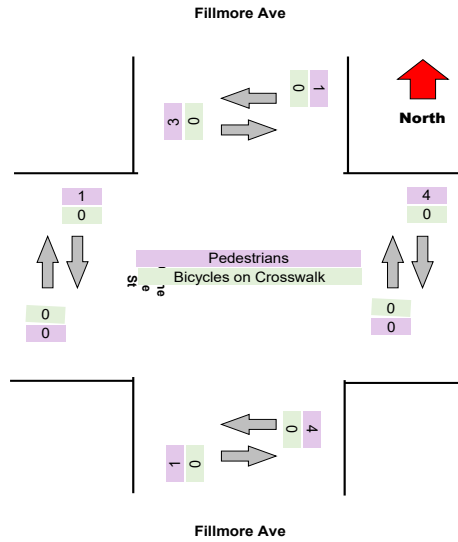
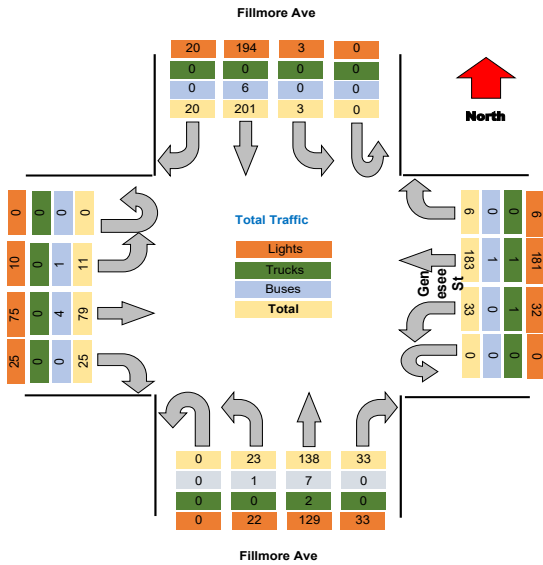

Project : VBH Malta NY  
Site : Site 4  
Location : 42.948550, -73.790036

TSTData.com

Survey Date : 2021-04-28, Wednesday

### Turning Movement Peak Hour Data (PM)

4:15:00 PM

Leg Direction	Fillmore Ave										Genesee St										Total	
	Southbound					Westbound					Northbound					Eastbound						
	Right	Thru	Left	U-Turn	App Total	Peds CW	Peds CCW	Right	Thru	Left	U-Turn	App Total	Peds CW	Peds CCW	Right	Thru	Left	U-Turn	App Total	Peds CW		Peds CCW
4:15:00 PM	12	72	4	0	88	0	1	6	50	17	0	73	0	1	18	71	9	0	98	1	0	322
4:30:00 PM	7	71	5	0	83	1	0	5	61	14	0	80	0	1	11	87	14	0	112	1	1	351
4:45:00 PM	12	67	5	0	84	2	0	5	54	18	0	77	1	2	21	64	5	0	90	1	4	318
5:00:00 PM	11	59	3	0	73	2	0	2	60	25	0	87	0	0	23	69	9	0	121	1	2	364
<b>Grand Total</b>	<b>42</b>	<b>269</b>	<b>17</b>	<b>0</b>	<b>328</b>	<b>5</b>	<b>1</b>	<b>18</b>	<b>225</b>	<b>74</b>	<b>0</b>	<b>317</b>	<b>1</b>	<b>4</b>	<b>73</b>	<b>311</b>	<b>37</b>	<b>0</b>	<b>421</b>	<b>4</b>	<b>7</b>	<b>1382</b>
% Approach	12.8%	82.0%	5.2%	0.0%	0.0%	0.0%	0.0%	5.7%	71.0%	23.3%	0.0%	0.0%	0.0%	0.0%	17.3%	73.9%	8.8%	0.0%	0.0%	0.0%	0.0%	0.0%
% Total	3.1%	19.9%	1.3%	0.0%	24.3%	0.0%	0.0%	1.3%	16.6%	5.5%	0.0%	23.4%	0.0%	0.0%	5.4%	23.0%	2.7%	0.0%	31.1%	0.0%	0.0%	0.0%
PHF	0.875	0.934	0.850	0.000	0.932	0.000	0.000	0.750	0.922	0.740	0.000	0.911	0.000	0.000	0.793	0.874	0.661	0.000	0.870	0.000	0.000	0.929
Lights	41	263	17	0	321	0	0	18	223	73	0	314	0	0	73	308	37	0	418	0	0	1336
% Lights	97.6%	97.8%	100.0%	0.0%	97.9%	0.0%	0.0%	100.0%	99.1%	98.6%	0.0%	99.1%	0.0%	0.0%	100.0%	99.0%	100.0%	0.0%	99.3%	0.0%	0.0%	98.8%
Trucks	0	1	0	0	1	0	0	0	0	0	0	0	0	0	0	1	0	0	1	0	0	2
% Trucks	0.0%	0.4%	0.0%	0.0%	0.3%	0.0%	0.0%	0.0%	0.0%	0.0%	0.0%	0.0%	0.0%	0.0%	0.0%	0.3%	0.0%	0.0%	0.2%	0.0%	0.0%	0.1%
Buses	1	5	0	0	6	0	0	0	2	1	0	3	0	0	0	2	0	0	2	0	0	14
% Buses	2.4%	1.9%	0.0%	0.0%	0.0%	0.0%	0.0%	0.0%	0.9%	1.4%	0.0%	0.0%	0.0%	0.0%	0.0%	0.6%	0.0%	0.0%	0.0%	0.0%	0.0%	1.0%
Pedestrians	0	0	0	0	0	5	1	0	0	0	0	1	4	0	0	0	0	0	3	7	0	7
% Pedestrians	0.0%	0.0%	0.0%	0.0%	0.0%	100.0%	100.0%	0.0%	0.0%	0.0%	0.0%	0.0%	100.0%	100.0%	0.0%	0.0%	0.0%	0.0%	0.0%	75.0%	100.0%	0.0%
Bicycles on Crosswalk	0	0	0	0	0	0	0	0	0	0	0	0	0	0	0	0	0	0	1	0	1	0
% Bicycles on Crosswalk	0.0%	0.0%	0.0%	0.0%	0.0%	0.0%	0.0%	0.0%	0.0%	0.0%	0.0%	0.0%	0.0%	0.0%	0.0%	0.0%	0.0%	0.0%	0.0%	25.0%	0.0%	0.0%

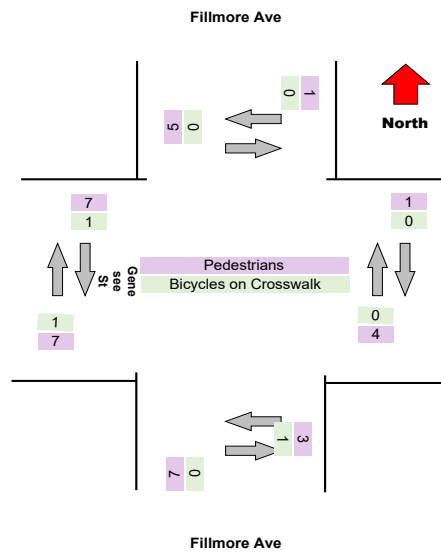
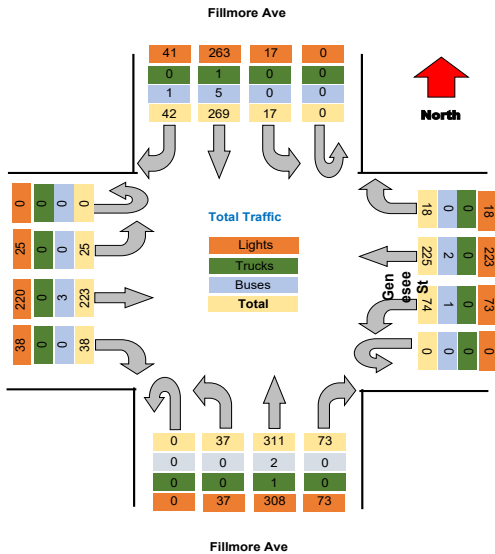



### Turning Movement Data Plot

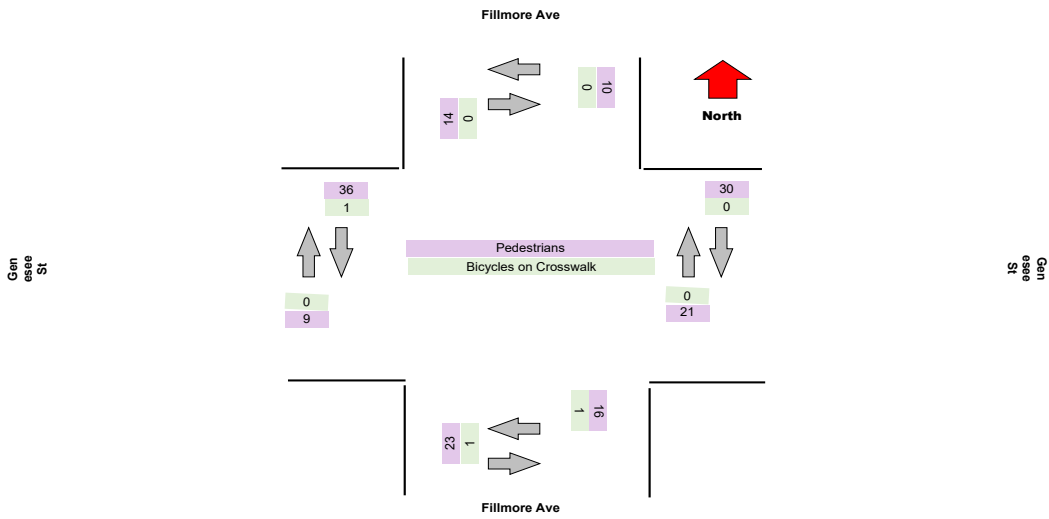
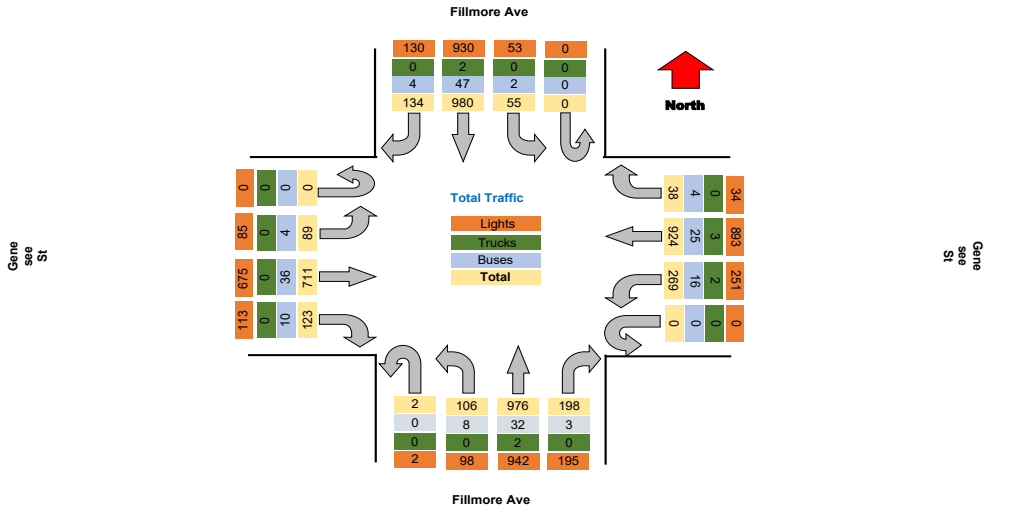

### Turning Movement Peak Hour Data (AM)

7:30:00 AM

Leg Direction	Fillmore Ave					Genesee St					Fillmore Ave					Genesee St					Total
	Southbound		Westbound			Northbound		Eastbound			Northbound		Eastbound								
Start Time	Right	Thru	Left	U-Turn	App Total	Peds CW	Peds CCW	Right	Thru	Left	U-Turn	App Total	Peds CW	Peds CCW	Right	Thru	Left	U-Turn	App Total	Peds CW	Peds CCW
7:30:00 AM	8	41	0	0	49	1	1	2	62	19	0	84	0	0	8	50	2	0	60	0	1
7:45:00 AM	7	78	2	0	87	0	0	4	85	26	0	115	0	0	9	65	13	0	87	0	1
8:00:00 AM	6	69	5	0	80	3	0	0	69	21	0	90	7	2	13	73	10	0	105	3	2
8:15:00 AM	5	75	3	0	83	0	0	2	69	16	0	85	0	0	7	63	14	0	84	1	2
<b>Grand Total</b>	<b>26</b>	<b>263</b>	<b>10</b>	<b>0</b>	<b>299</b>	<b>4</b>	<b>1</b>	<b>8</b>	<b>296</b>	<b>62</b>	<b>0</b>	<b>357</b>	<b>7</b>	<b>2</b>	<b>37</b>	<b>251</b>	<b>39</b>	<b>0</b>	<b>336</b>	<b>4</b>	<b>6</b>
% Approach	8.7%	88.0%	3.3%	0.0%	0.0%	0.0%	0.0%	2.1%	76.5%	21.2%	0.0%	0.0%	0.0%	0.0%	11.0%	74.7%	11.6%	0.0%	0.0%	0.0%	0.0%
% Total	2.1%	21.6%	0.8%	0.0%	24.5%	0.0%	0.0%	0.7%	24.3%	6.7%	0.0%	31.8%	0.0%	0.0%	3.0%	20.6%	3.2%	0.0%	27.6%	0.0%	0.0%
PHF	0.813	0.843	0.500	0.000	0.859	0.000	0.000	0.500	0.871	0.788	0.000	0.841	0.000	0.000	0.712	0.860	0.696	0.000	0.800	0.000	0.000
Lights	25	246	10	0	281	0	0	6	289	71	0	366	0	0	36	238	36	0	310	0	0
% Lights	86.2%	93.5%	100.0%	0.0%	94.0%	0.0%	0.0%	75.0%	97.6%	86.6%	0.0%	94.6%	0.0%	0.0%	87.3%	94.8%	92.3%	0.0%	92.3%	0.0%	0.0%
Trucks	0	0	0	0	0	0	0	0	2	2	0	4	0	0	0	0	0	0	0	0	0
% Trucks	0.0%	0.0%	0.0%	0.0%	0.0%	0.0%	0.0%	0.0%	0.7%	2.4%	1.0%	1.0%	0.0%	0.0%	0.0%	0.0%	0.0%	0.0%	0.0%	0.0%	0.0%
Buses	1	16	0	0	17	0	0	2	5	9	0	16	0	0	1	13	3	0	17	0	0
% Buses	3.8%	6.1%	0.0%	0.0%	5.7%	0.0%	0.0%	25.0%	1.7%	11.0%	0.0%	4.5%	0.0%	0.0%	2.7%	5.2%	7.7%	0.0%	5.1%	0.0%	0.0%
Pedestrians	0	0	0	0	0	4	1	0	0	0	0	7	2	0	0	0	0	0	0	4	6
% Pedestrians	0.0%	0.0%	0.0%	0.0%	0.0%	100.0%	100.0%	0.0%	0.0%	0.0%	0.0%	0.0%	100.0%	100.0%	0.0%	0.0%	0.0%	0.0%	0.0%	100.0%	100.0%
Bicycles on Crosswalk	0	0	0	0	0	0	0	0	0	0	0	0	0	0	0	0	0	0	0	0	0
% Bicycles on Crosswalk	0.0%	0.0%	0.0%	0.0%	0.0%	0.0%	0.0%	0.0%	0.0%	0.0%	0.0%	0.0%	0.0%	0.0%	0.0%	0.0%	0.0%	0.0%	0.0%	0.0%	0.0%

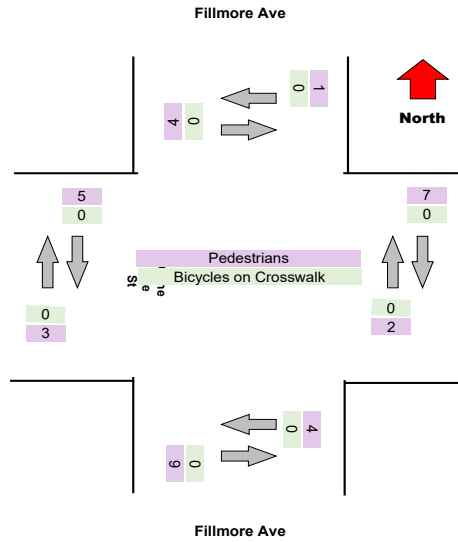
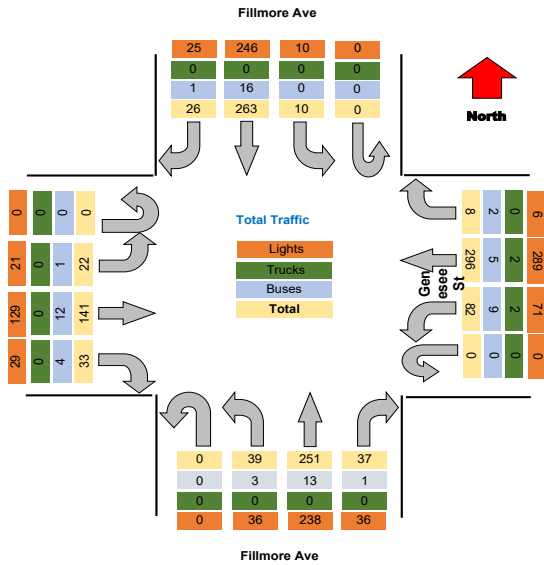



Project : VBH Malta NY  
Site : Site 4  
Location : 42.948550, -73.790036

TSTData.com

Survey Date : 2021-04-28, Wednesday

**Turning Movement Peak Hour Data (PM)**

4:15:00 PM

Leg Direction	Fillmore Ave					Genesee St					Fillmore Ave					Genesee St					Total	
	Southbound					Westbound					Northbound					Eastbound						
Start Time	Right	Thru	Left	U-Turn	App Total	Peds CW	Peds CCW	Right	Thru	Left	U-Turn	App Total	Peds CW	Peds CCW	Right	Thru	Left	U-Turn	App Total	Peds CW	Peds CCW	Total
4:15:00 PM	8	74	3	0	85	0	1	3	60	23	0	86	2	5	20	78	8	0	106	0	5	362
4:30:00 PM	14	81	3	0	98	0	0	5	77	15	0	97	2	1	23	97	5	0	125	2	1	416
4:45:00 PM	20	85	8	0	113	4	0	4	87	17	0	88	2	4	14	94	6	0	114	1	0	404
5:00:00 PM	9	89	4	0	102	1	0	3	98	16	0	77	3	1	22	75	5	0	102	1	2	349
<b>Grand Total</b>	<b>51</b>	<b>309</b>	<b>18</b>	<b>0</b>	<b>378</b>	<b>6</b>	<b>1</b>	<b>15</b>	<b>262</b>	<b>71</b>	<b>0</b>	<b>348</b>	<b>8</b>	<b>11</b>	<b>79</b>	<b>344</b>	<b>24</b>	<b>0</b>	<b>447</b>	<b>4</b>	<b>8</b>	<b>1531</b>
% Approach	13.5%	81.7%	4.8%	0.0%	0.0%	0.0%	0.0%	4.3%	75.3%	20.4%	0.0%	0.0%	0.0%	0.0%	17.7%	77.0%	5.4%	0.0%	0.0%	0.0%	0.0%	13.4%
% Total	3.3%	20.2%	1.2%	0.0%	24.7%	0.0%	0.0%	1.0%	17.1%	4.6%	0.0%	22.7%	0.0%	0.0%	5.2%	22.5%	1.6%	0.0%	29.2%	0.0%	0.0%	3.1%
PHF	0.638	0.909	0.563	0.000	0.836	0.000	0.000	0.750	0.851	0.772	0.000	0.897	0.000	0.000	0.859	0.887	0.750	0.000	0.894	0.000	0.000	0.857
Lights	48	296	18	0	362	0	0	13	251	68	0	332	0	0	77	339	23	0	439	0	0	1472
% Lights	84.1%	95.8%	100.0%	0.0%	95.8%	0.0%	0.0%	86.7%	95.8%	95.8%	0.0%	95.4%	0.0%	0.0%	87.5%	98.5%	95.8%	0.0%	98.2%	0.0%	0.0%	93.8%
Trucks	0	2	0	0	2	0	0	0	0	0	0	0	0	0	0	1	0	0	1	0	0	3
% Trucks	0.0%	0.6%	0.0%	0.0%	0.5%	0.0%	0.0%	0.0%	0.0%	0.0%	0.0%	0.0%	0.0%	0.0%	0.0%	0.3%	0.0%	0.0%	0.2%	0.0%	0.0%	0.2%
Buses	3	11	0	0	14	0	0	2	8	3	0	13	0	0	2	4	1	0	7	0	0	53
% Buses	5.9%	3.6%	0.0%	0.0%	0.0%	0.0%	0.0%	13.3%	3.1%	4.2%	0.0%	0.0%	0.0%	0.0%	2.5%	1.2%	4.2%	0.0%	0.0%	0.0%	0.0%	6.3%
Pedestrians	0	0	0	0	0	5	4	0	0	0	0	0	9	11	0	0	0	0	0	4	7	0
% Pedestrians	0.0%	0.0%	0.0%	0.0%	0.0%	100.0%	100.0%	0.0%	0.0%	0.0%	0.0%	0.0%	100.0%	100.0%	0.0%	0.0%	0.0%	0.0%	0.0%	0.9%	100.0%	87.5%
Bicycles on Crosswalk	0	0	0	0	0	0	0	0	0	0	0	0	0	0	0	0	0	0	0	0	1	0
% Bicycles on Crosswalk	0.0%	0.0%	0.0%	0.0%	0.0%	0.0%	0.0%	0.0%	0.0%	0.0%	0.0%	0.0%	0.0%	0.0%	0.0%	0.0%	0.0%	0.0%	0.0%	0.0%	12.5%	0.0%

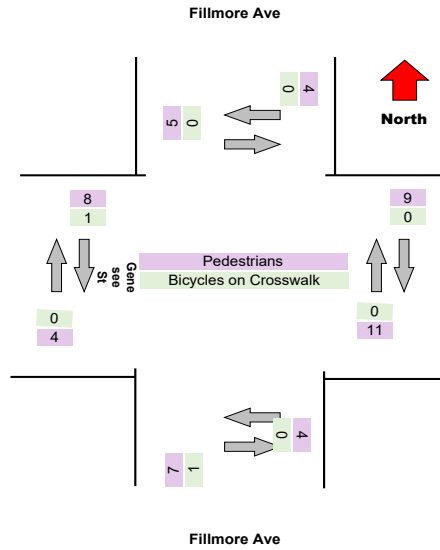
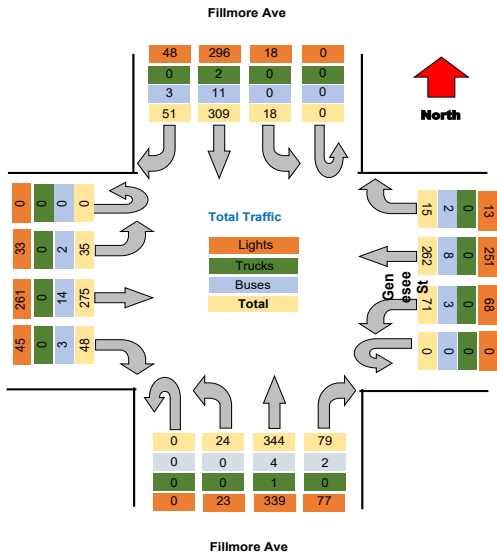

Project : VBH Malta NY  
 Site : Site 4  
 Location : 42.948550, -73.790036

TSTData.com

Survey Date : 2021-04-28, Wednesday

Project	LaBella
Project Code	LaBella
Site Name	15
Legs and Movements	All Processed Legs & Move
Bin Size	15 minutes
Survey Date	2021-11-04, Thursday
Location	15
Latitude and Longitude	42.902329, -78.839303

	Start	End	PHF
Forced Peak AM	2021/11/04 07:30:00	2021/11/04 08:30:00	0.87
Forced Peak PM	2021/11/04 16:30:00	2021/11/04 17:30:00	0.95
AM Peak	2021/11/04 07:30:00	2021/11/04 08:30:00	0.87
PM Peak	2021/11/04 16:15:00	2021/11/04 17:15:00	0.95

### Turning Movement Data

Leg Direction	Fillmore Ave							Genesee St							Fillmore Ave							Genesee St							Total	
	Southbound			Northbound				Westbound			Eastbound				Northbound			Southbound												
Start Time	Right	Thru	Left	U-Turn	App Total	Peds CV	Peds CCV	Right	Thru	Left	U-Turn	App Total	Peds CV	Peds CCV	Right	Thru	Left	U-Turn	App Total	Peds CV	Peds CCV	Right	Thru	Left	U-Turn	App Total	Peds CV	Peds CCV		
6:30:00 AM	1	24	0	0	25	0	1	0	26	6	0	33	0	0	6	19	3	0	28	0	0	5	7	3	0	15	1	2	101	
6:45:00 AM	2	40	2	0	44	0	0	0	44	4	0	48	0	1	2	17	5	0	25	0	0	3	16	1	0	20	0	0	137	
Hourly Total	3	64	2	0	69	0	1	0	70	10	0	81	0	1	8	36	8	0	53	0	2	5	23	4	0	35	1	2	238	
7:00:00 AM	2	32	1	0	35	0	0	0	37	10	0	47	0	0	6	35	2	0	43	0	2	2	20	0	0	22	0	0	143	
7:15:00 AM	0	32	1	0	33	0	2	0	33	4	0	37	0	2	4	35	5	0	42	1	0	2	20	1	0	23	0	3	167	
7:30:00 AM	10	44	1	0	55	1	0	1	70	19	0	90	0	0	4	46	1	0	51	0	1	8	29	2	0	39	1	0	235	
7:45:00 AM	5	71	1	0	77	0	0	3	82	23	0	118	0	1	12	55	8	0	75	0	0	6	31	7	0	44	0	0	315	
Hourly Total	17	179	4	0	200	1	2	4	232	56	0	294	12	3	26	171	16	0	228	1	3	18	100	10	0	128	1	3	850	
8:00:00 AM	13	84	3	0	100	3	1	0	59	19	0	79	2	3	19	59	10	0	83	1	5	5	50	9	0	64	2	2	336	
8:15:00 AM	6	72	3	0	81	0	1	0	55	14	0	70	0	0	9	55	9	0	73	2	0	8	37	8	0	53	0	1	277	
Hourly Total	19	156	6	0	181	3	2	0	114	33	0	149	2	3	28	114	19	0	166	3	5	13	87	17	0	117	2	3	613	
4:00:00 PM	6	92	2	0	100	2	4	3	58	18	0	79	3	4	19	76	13	0	108	1	1	19	81	15	0	115	0	6	402	
4:15:00 PM	10	78	6	0	94	1	2	6	84	11	0	101	0	2	15	79	17	0	111	2	2	18	74	5	0	97	0	3	403	
4:30:00 PM	14	77	1	0	92	2	1	4	86	17	0	97	1	0	14	93	6	0	113	0	2	11	82	7	0	100	1	2	392	
4:45:00 PM	12	86	3	0	101	0	1	5	89	13	0	102	0	0	20	70	7	0	97	3	3	14	74	7	0	95	3	3	371	
Hourly Total	42	333	12	0	387	5	8	18	268	59	0	345	4	6	68	318	43	0	429	6	8	62	311	34	0	497	4	16	1568	
5:00:00 PM	10	87	5	0	102	0	1	10	89	24	0	103	2	1	20	84	6	0	110	1	0	6	81	9	0	78	1	4	363	
5:15:00 PM	11	82	6	0	99	1	0	7	74	18	0	99	2	0	16	72	6	0	94	2	0	9	71	5	0	85	0	0	387	
5:30:00 PM	7	77	6	0	90	0	1	4	51	19	0	74	3	2	22	60	6	0	88	1	2	8	64	5	0	77	1	1	329	
5:45:00 PM	17	64	6	0	87	1	2	5	69	12	0	86	1	0	16	70	10	0	86	2	2	14	47	8	0	69	0	2	338	
Hourly Total	45	280	23	0	328	2	4	26	263	73	0	362	8	3	74	286	28	0	388	6	4	39	243	27	0	309	2	7	1387	
Grand Total	126	992	47	0	1165	11	17	48	947	231	0	1231	26	16	204	925	114	0	1284	16	22	140	764	92	0	996	19	31	4686	
% Approach	10.8%	85.2%	4.0%	0.0%	0.0%	0.0%	0.0%	3.9%	76.9%	18.8%	0.0%	0.0%	0.0%	0.0%	16.1%	73.2%	9.0%	0.0%	0.0%	0.0%	0.0%	14.1%	76.7%	9.2%	0.0%	0.0%	0.0%	0.0%	0.0%	
% Total	2.7%	21.3%	1.0%	0.0%	25.0%	0.0%	0.0%	1.0%	20.3%	5.0%	0.0%	26.4%	0.0%	0.0%	4.4%	19.9%	2.4%	0.0%	27.1%	0.0%	0.0%	3.0%	16.4%	2.0%	0.0%	21.4%	0.0%	0.0%	0.0%	
Lights	123	944	45	0	1112	0	0	46	919	215	0	1180	0	0	196	878	105	0	1179	0	0	130	724	87	0	941	0	0	4412	
% Lights	97.6%	95.2%	95.7%	0.0%	95.5%	0.0%	0.0%	95.9%	97.0%	93.1%	0.0%	95.9%	0.0%	0.0%	96.1%	94.9%	92.1%	0.0%	93.3%	0.0%	0.0%	92.9%	94.8%	94.6%	0.0%	94.5%	0.0%	0.0%	94.8%	
Trucks	0	5	0	0	5	0	0	0	1	0	0	1	0	0	1	7	0	0	8	0	0	0	4	0	0	4	0	0	16	
% Trucks	0.0%	0.5%	0.0%	0.0%	0.4%	0.0%	0.0%	0.0%	0.1%	0.0%	0.0%	0.1%	0.0%	0.0%	0.5%	0.8%	0.0%	0.0%	0.6%	0.0%	0.0%	0.0%	0.5%	0.0%	0.0%	0.4%	0.0%	0.0%	0.4%	
Buses	3	43	2	0	48	0	0	2	27	16	0	45	0	0	7	40	9	0	56	0	0	9	36	5	0	50	0	0	199	
% Buses	2.4%	4.3%	4.3%	0.0%	0.0%	0.0%	0.0%	0.0%	2.9%	6.9%	0.0%	0.0%	0.0%	0.0%	3.4%	4.3%	7.9%	0.0%	0.0%	0.0%	0.0%	6.4%	4.7%	5.4%	0.0%	0.0%	0.0%	0.0%	4.3%	
Pedestrians	0	0	0	0	0	10	16	0	0	0	0	0	26	16	0	0	0	0	0	16	22	0	0	0	0	0	0	9	30	0
% Pedestrians	0.0%	0.0%	0.0%	0.0%	0.0%	89.8%	84.1%	0.0%	0.0%	0.0%	0.0%	0.0%	100.0%	100.0%	0.0%	0.0%	0.0%	0.0%	0.0%	100.0%	100.0%	0.0%	0.0%	0.0%	0.0%	0.0%	0.0%	80.0%	86.8%	0.0%
Bicycles on Crosswalk	0	0	0	0	0	1	1	0	0	0	0	0	0	0	0	0	0	0	0	0	0	0	0	0	0	0	1	1	0	
% Bicycles on Crosswalk	0.0%	0.0%	0.0%	0.0%	0.0%	9.1%	5.9%	0.0%	0.0%	0.0%	0.0%	0.0%	0.0%	0.0%	0.0%	0.0%	0.0%	0.0%	0.0%	0.0%	0.0%	0.0%	0.0%	0.0%	0.0%	0.0%	0.0%	10.0%	5.2%	0.0%

Project : VBH Malta NY  
 Site : Site 4  
 Location : 42.948550, -73.790036  
 Survey Date : 2021-04-28, Wednesday

### Turning Movement Data Plot

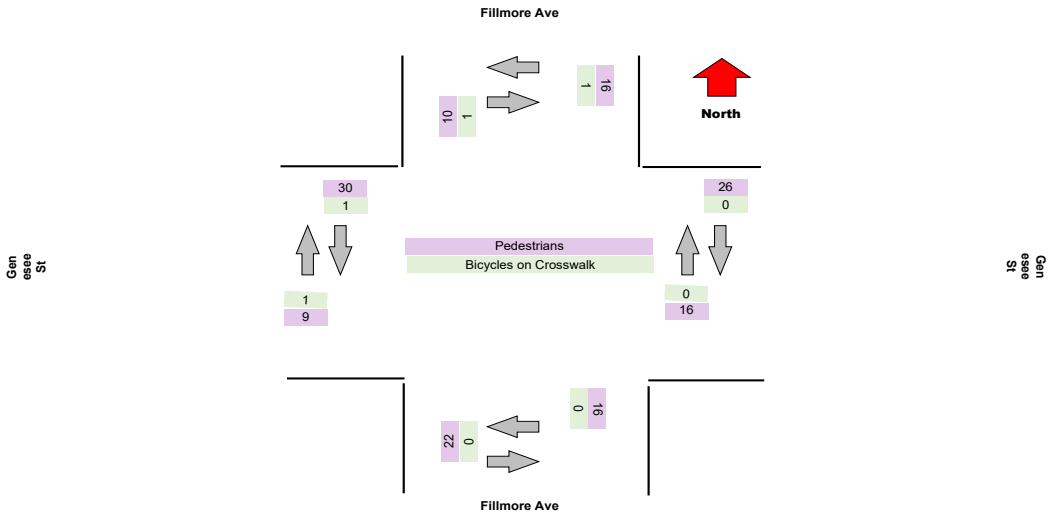
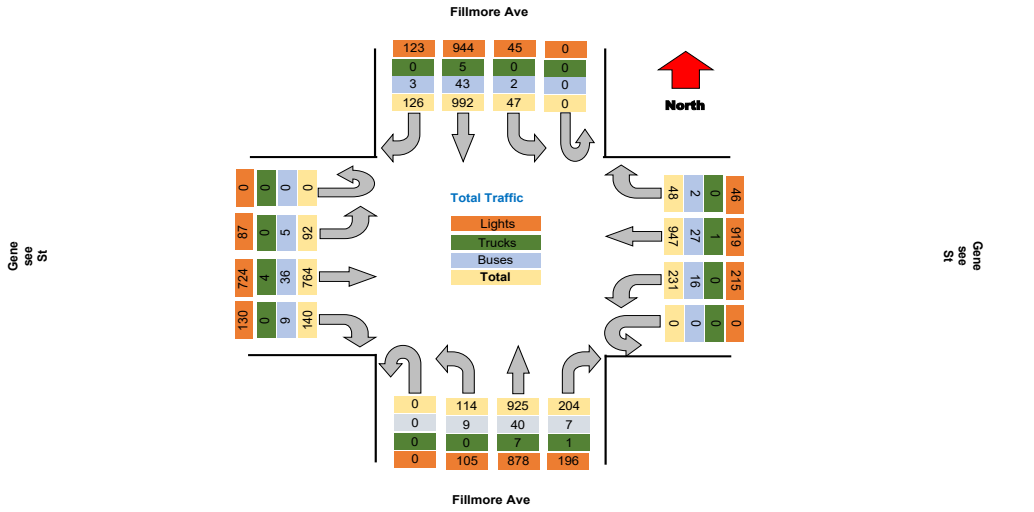

Project : VBH Malta NY  
Site : Site 4  
Location : 42.948550, -73.790036

TSTData.com

Survey Date : 2021-04-28, Wednesday

### Turning Movement Peak Hour Data (AM)

7:30:00 AM

Leg Direction	Fillmore Ave					Genesee St					Fillmore Ave					Genesee St					Total	
	Southbound					Westbound					Northbound					Eastbound						
Start Time	Right	Thru	Left	U-Turn	App Total	Peds CW	Peds CCW	Right	Thru	Left	U-Turn	App Total	Peds CW	Peds CCW	Right	Thru	Left	U-Turn	App Total	Peds CW	Peds CCW	Total
7:30:00 AM	10	44	1	0	55	1	0	1	70	19	0	90	0	0	4	46	1	0	51	0	1	235
7:45:00 AM	5	71	1	0	77	0	0	3	92	23	0	118	0	1	12	55	8	0	76	0	0	316
8:00:00 AM	13	84	3	0	100	3	1	0	59	19	0	79	2	3	19	59	10	0	93	1	5	336
8:15:00 AM	6	72	3	0	81	0	0	0	55	14	0	70	0	0	9	56	9	0	73	2	0	277
<b>Grand Total</b>	<b>34</b>	<b>271</b>	<b>8</b>	<b>0</b>	<b>313</b>	<b>4</b>	<b>1</b>	<b>4</b>	<b>276</b>	<b>75</b>	<b>0</b>	<b>357</b>	<b>2</b>	<b>4</b>	<b>44</b>	<b>215</b>	<b>28</b>	<b>0</b>	<b>293</b>	<b>3</b>	<b>6</b>	<b>1163</b>
% Approach	10.9%	86.6%	2.6%	0.0%	0.0%	0.0%	0.0%	1.1%	77.3%	21.0%	0.0%	0.0%	0.0%	0.0%	15.0%	73.4%	9.6%	0.0%	0.0%	0.0%	0.0%	0.0%
% Total	2.9%	23.3%	0.7%	0.0%	26.9%	0.0%	0.0%	0.3%	23.7%	6.4%	0.0%	30.7%	0.0%	0.0%	3.8%	18.5%	2.4%	0.0%	25.2%	0.0%	0.0%	0.0%
PHF	0.654	0.807	0.667	0.000	0.783	0.000	0.000	0.333	0.750	0.815	0.000	0.756	0.000	0.000	0.579	0.911	0.700	0.000	0.788	0.000	0.000	0.865
Lights	33	255	7	0	295	0	0	3	270	67	0	340	0	0	39	198	25	0	262	0	0	1079
% Lights	87.1%	84.1%	87.5%	0.0%	94.2%	0.0%	0.0%	75.0%	97.8%	89.3%	0.0%	95.2%	0.0%	0.0%	88.6%	92.1%	89.3%	0.0%	89.4%	0.0%	0.0%	92.8%
Trucks	0	1	0	0	1	0	0	0	0	0	0	0	0	0	1	1	0	0	2	0	0	6
% Trucks	0.0%	0.4%	0.0%	0.0%	0.3%	0.0%	0.0%	0.0%	0.0%	0.0%	0.0%	0.0%	0.0%	0.0%	2.3%	0.5%	0.0%	0.0%	0.7%	0.0%	0.0%	0.5%
Buses	1	15	1	0	17	0	0	1	6	8	0	15	0	0	4	16	3	0	23	0	0	70
% Buses	2.9%	5.5%	12.5%	0.0%	0.0%	0.0%	0.0%	25.0%	2.2%	10.7%	0.0%	0.0%	0.0%	0.0%	9.1%	7.4%	10.7%	0.0%	0.0%	0.0%	0.0%	6.0%
Pedestrians	0	0	0	0	0	4	2	0	0	0	0	2	4	0	0	0	0	0	0	3	6	0
% Pedestrians	0.0%	0.0%	0.0%	0.0%	0.0%	100.0%	100.0%	0.0%	0.0%	0.0%	0.0%	0.0%	100.0%	100.0%	0.0%	0.0%	0.0%	0.0%	0.0%	0.0%	100.0%	0.0%
Bicycles on Crosswalk	0	0	0	0	0	0	0	0	0	0	0	0	0	0	0	0	0	0	0	0	0	0
% Bicycles on Crosswalk	0.0%	0.0%	0.0%	0.0%	0.0%	0.0%	0.0%	0.0%	0.0%	0.0%	0.0%	0.0%	0.0%	0.0%	0.0%	0.0%	0.0%	0.0%	0.0%	0.0%	0.0%	0.0%

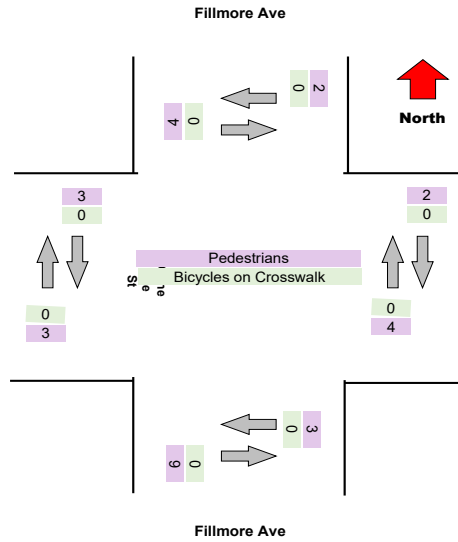
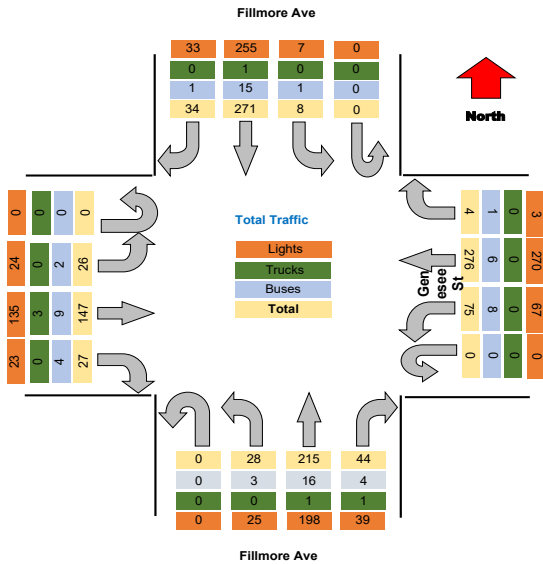

Project : VBH Malta NY  
Site : Site 4  
Location : 42.948550, -73.790036

TSTData.com

Survey Date : 2021-04-28, Wednesday

### Turning Movement Peak Hour Data (PM)

4:15:00 PM

Leg Direction	Fillmore Ave										Genesee St										Total									
	Southbound					Westbound					Northbound					Eastbound														
	Right	Thru	Left	U-Turn	App Total	Peds CW	Peds CCW	Right	Thru	Left	U-Turn	App Total	Peds CW	Peds CCW	Right	Thru	Left	U-Turn	App Total	Peds CW		Peds CCW								
4:15:00 PM	10	78	6	0	94	1	2	6	84	11	0	101	0	2	15	79	17	0	111	2	2	18	74	5	0	97	0	3	403	
4:30:00 PM	14	77	1	0	92	2	1	4	66	17	0	87	1	0	14	93	6	0	113	0	2	11	82	7	0	100	1	2	392	
4:45:00 PM	12	86	3	0	101	0	1	5	60	13	0	78	0	0	20	70	7	0	97	3	3	14	74	7	0	95	3	3	371	
5:00:00 PM	10	57	5	0	72	0	1	10	69	24	0	103	2	1	20	84	6	0	110	1	0	8	61	9	0	78	1	4	363	
<b>Grand Total</b>	<b>46</b>	<b>288</b>	<b>15</b>	<b>0</b>	<b>349</b>	<b>3</b>	<b>5</b>	<b>25</b>	<b>279</b>	<b>85</b>	<b>0</b>	<b>359</b>	<b>3</b>	<b>3</b>	<b>69</b>	<b>335</b>	<b>36</b>	<b>0</b>	<b>431</b>	<b>6</b>	<b>7</b>	<b>51</b>	<b>251</b>	<b>29</b>	<b>0</b>	<b>370</b>	<b>3</b>	<b>12</b>	<b>1529</b>	
% Approach	12.8%	83.0%	4.2%	0.0%	0.0%	0.0%	0.0%	6.8%	75.6%	17.6%	0.0%	0.0%	0.0%	0.0%	16.0%	75.6%	8.4%	0.0%	0.0%	0.0%	0.0%	13.8%	75.6%	7.6%	0.0%	0.0%	0.0%	0.0%		
% Total	3.0%	19.5%	1.0%	0.0%	23.5%	0.0%	0.0%	1.6%	18.2%	4.3%	0.0%	24.1%	0.0%	0.0%	4.5%	21.3%	2.4%	0.0%	28.2%	0.0%	0.0%	3.3%	19.0%	1.8%	0.0%	24.2%	0.0%	0.0%		
PHF	0.821	0.866	0.625	0.000	0.889	0.000	0.000	0.625	0.830	0.677	0.000	0.896	0.000	0.000	0.863	0.876	0.529	0.000	0.854	0.000	0.000	0.708	0.887	0.778	0.000	0.925	0.000	0.000	0.949	
Lights	44	285	15	0	344	0	0	24	273	60	0	357	0	0	66	314	35	0	415	0	0	48	278	27	0	353	0	0	1469	
% Lights	95.7%	95.6%	100.0%	0.0%	95.8%	0.0%	0.0%	96.0%	97.8%	92.3%	0.0%	96.7%	0.0%	0.0%	95.7%	96.3%	97.2%	0.0%	96.3%	0.0%	0.0%	94.1%	95.5%	96.4%	0.0%	95.4%	0.0%	0.0%	96.1%	
Trucks	0	3	0	0	3	0	0	0	0	0	0	0	0	0	0	3	0	0	3	0	0	0	0	0	0	0	0	0	6	
% Trucks	0.0%	1.0%	0.0%	0.0%	0.8%	0.0%	0.0%	0.0%	0.0%	0.0%	0.0%	0.0%	0.0%	0.0%	0.0%	0.9%	0.0%	0.0%	0.7%	0.0%	0.0%	0.0%	0.0%	0.0%	0.0%	0.0%	0.0%	0.0%	0.4%	
Buses	2	10	0	0	12	0	0	1	6	5	0	12	0	0	3	9	1	0	13	0	0	2	13	1	0	16	0	0	53	
% Buses	4.3%	3.4%	0.0%	0.0%	0.0%	0.0%	0.0%	4.0%	2.2%	7.7%	0.0%	0.0%	0.0%	0.0%	4.3%	2.8%	2.8%	0.0%	0.0%	0.0%	0.0%	3.9%	4.5%	3.6%	0.0%	0.0%	0.0%	3.5%		
Pedestrians	0	0	0	0	0	3	5	0	0	0	0	0	3	3	0	0	0	0	6	6	7	0	0	0	0	0	4	11	0	
% Pedestrians	0.0%	0.0%	0.0%	0.0%	0.0%	100.0%	100.0%	0.0%	0.0%	0.0%	0.0%	0.0%	100.0%	100.0%	0.0%	0.0%	0.0%	0.0%	0.0%	0.0%	0.0%	0.0%	0.0%	0.0%	0.0%	0.0%	0.0%	80.0%	91.7%	0.0%
Bicycles on Crosswalk	0	0	0	0	0	0	0	0	0	0	0	0	0	0	0	0	0	0	0	0	0	0	0	0	0	0	1	1	0	
% Bicycles on Crosswalk	0.0%	0.0%	0.0%	0.0%	0.0%	0.0%	0.0%	0.0%	0.0%	0.0%	0.0%	0.0%	0.0%	0.0%	0.0%	0.0%	0.0%	0.0%	0.0%	0.0%	0.0%	0.0%	0.0%	0.0%	0.0%	0.0%	20.0%	8.3%	0.0%	

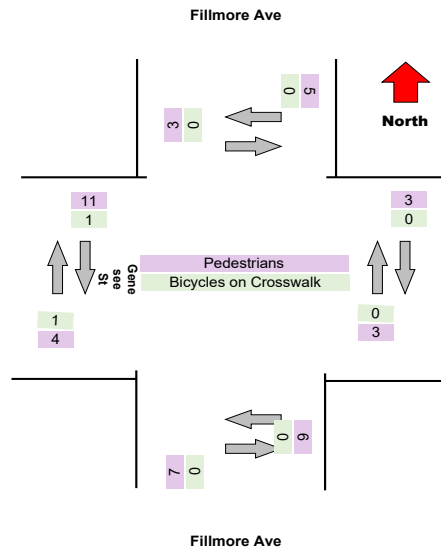
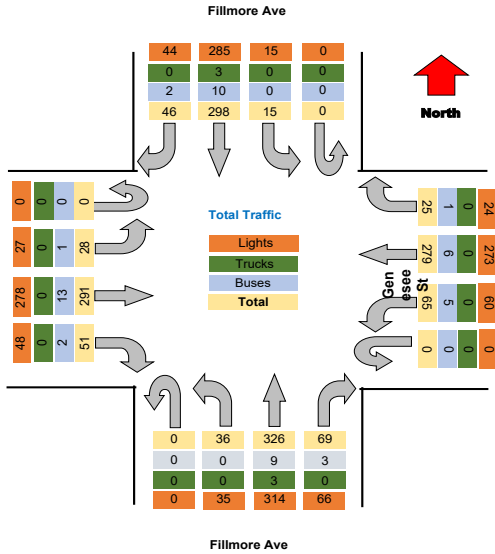



Project : VBH Malta NY  
 Site : Site 4  
 Location : 42.948550, -73.790036  
 Survey Date : 2021-04-28, Wednesday

### Turning Movement Data Plot

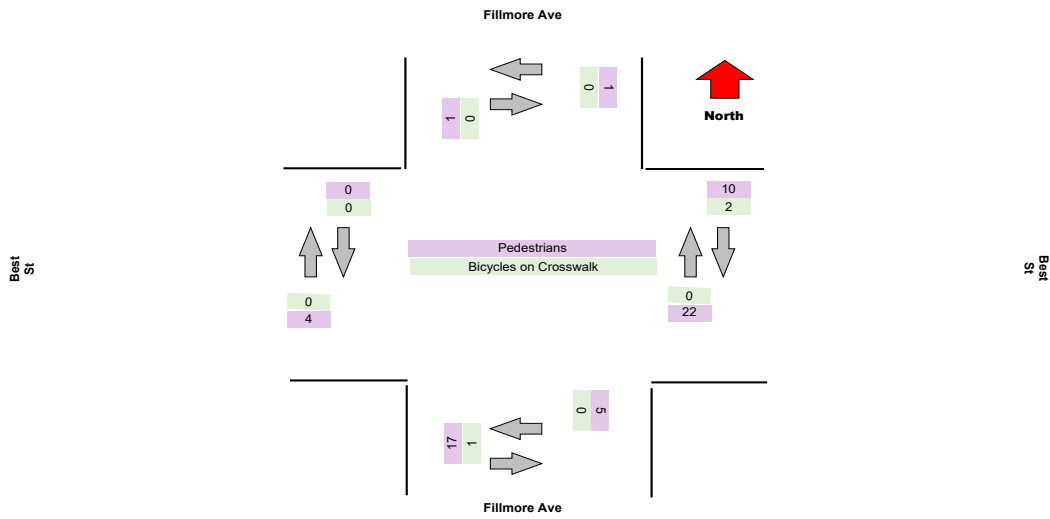
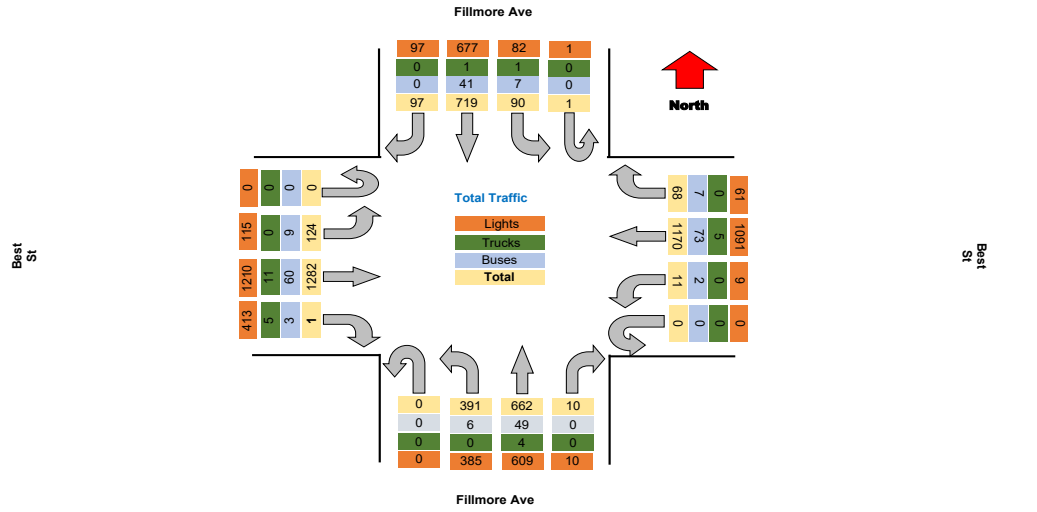

Project : VBH Malta NY  
Site : Site 4  
Location : 42.948550, -73.790036

TSTData.com

Survey Date : 2021-04-28, Wednesday

**Turning Movement Peak Hour Data (AM)**

7:30:00 AM

Leg Direction	Fillmore Ave						Best St						Fillmore Ave						Best St						Total					
	Southbound			Northbound			Westbound			Eastbound			Northbound			Eastbound														
Start Time	Right	Thru	Left	U-Turn	App Total	Peds CW	Peds CCW	Right	Thru	Left	U-Turn	App Total	Peds CW	Peds CCW	Right	Thru	Left	U-Turn	App Total	Peds CW	Peds CCW	Right	Thru	Left	U-Turn	App Total	Peds CW	Peds CCW		
7:30:00 AM	7	28	8	0	43	0	0	4	66	1	0	71	0	4	1	39	15	0	59	0	2	24	45	4	0	73	0	0	246	
7:45:00 AM	7	55	3	0	65	0	0	6	107	0	0	113	4	2	1	39	30	0	76	0	1	34	69	6	0	109	1	0	363	
8:00:00 AM	6	56	8	0	70	1	0	3	78	0	0	81	0	2	0	44	30	0	76	1	1	46	79	8	0	133	0	0	360	
8:15:00 AM	4	54	10	0	68	0	0	3	69	1	0	74	3	1	0	37	29	0	70	2	1	28	65	9	0	102	0	0	334	
<b>Grand Total</b>	<b>24</b>	<b>193</b>	<b>29</b>	<b>0</b>	<b>246</b>	<b>1</b>	<b>0</b>	<b>16</b>	<b>341</b>	<b>2</b>	<b>0</b>	<b>359</b>	<b>7</b>	<b>9</b>	<b>2</b>	<b>159</b>	<b>104</b>	<b>0</b>	<b>281</b>	<b>3</b>	<b>5</b>	<b>132</b>	<b>258</b>	<b>27</b>	<b>0</b>	<b>417</b>	<b>1</b>	<b>0</b>	<b>1383</b>	
<b>% Approach</b>	9.8%	78.5%	11.8%	0.0%	0.0%	0.0%	0.0%	14.2%	85.8%	0.0%	0.0%	0.0%	0.0%	0.0%	45.1%	41.7%	13.2%	0.0%	0.0%	0.0%	0.0%	0.0%	66.2%	33.8%	0.0%	0.0%	0.0%	0.0%	0.0%	
<b>% Total</b>	1.8%	14.8%	2.2%	0.0%	18.8%	0.0%	0.0%	1.2%	26.2%	0.2%	0.0%	27.6%	0.0%	0.0%	0.2%	12.2%	8.0%	0.0%	21.6%	0.0%	0.0%	10.1%	19.8%	2.1%	0.0%	32.0%	0.0%	0.0%	0.0%	
<b>PHF</b>	0.857	0.862	0.725	0.000	0.879	0.000	0.000	0.667	0.787	0.500	0.000	0.794	0.000	0.000	0.500	0.903	0.867	0.000	0.824	0.000	0.000	0.717	0.816	0.750	0.000	0.784	0.000	0.000	0.887	
<b>Lights</b>	24	192	23	0	229	0	0	13	322	1	0	336	0	0	2	142	100	0	244	0	0	131	241	27	0	399	0	0	1208	
<b>% Lights</b>	100.0%	94.3%	79.3%	0.0%	93.1%	0.0%	0.0%	81.3%	94.4%	50.0%	0.0%	93.6%	0.0%	0.0%	100.0%	89.3%	96.2%	0.0%	86.8%	0.0%	0.0%	99.2%	93.4%	100.0%	0.0%	95.7%	0.0%	0.0%	92.7%	
<b>Trucks</b>	0	0	0	0	0	0	0	0	3	0	0	3	0	0	0	2	0	0	2	0	0	1	6	0	0	7	0	0	12	
<b>% Trucks</b>	0.0%	0.0%	0.0%	0.0%	0.0%	0.0%	0.0%	0.0%	0.9%	0.0%	0.0%	0.8%	0.0%	0.0%	0.0%	1.3%	0.0%	0.0%	0.7%	0.0%	0.0%	0.8%	2.3%	0.0%	0.0%	1.7%	0.0%	0.0%	0.9%	
<b>Buses</b>	0	11	6	0	17	0	0	3	15	1	0	19	0	0	0	15	4	0	19	0	0	0	11	0	0	11	0	0	66	
<b>% Buses</b>	0.0%	5.7%	20.7%	0.0%	0.0%	0.0%	0.0%	18.8%	4.4%	50.0%	0.0%	0.0%	0.0%	0.0%	0.0%	9.4%	3.8%	0.0%	0.0%	0.0%	0.0%	0.0%	4.3%	0.0%	0.0%	0.0%	0.0%	0.0%	5.1%	
<b>Pedestrians</b>	0	0	0	0	0	1	0	0	0	0	0	7	9	0	0	0	0	0	3	5	0	0	0	0	0	0	1	0	0	
<b>% Pedestrians</b>	0.0%	0.0%	0.0%	0.0%	0.0%	100.0%	0.0%	0.0%	0.0%	0.0%	0.0%	0.0%	100.0%	100.0%	0.0%	0.0%	0.0%	0.0%	0.0%	100.0%	100.0%	0.0%	0.0%	0.0%	0.0%	0.0%	0.0%	100.0%	0.0%	0.0%
<b>Bicycles on Crosswalk</b>	0	0	0	0	0	0	0	0	0	0	0	0	0	0	0	0	0	0	0	0	0	0	0	0	0	0	0	0	0	
<b>% Bicycles on Crosswalk</b>	0.0%	0.0%	0.0%	0.0%	0.0%	0.0%	0.0%	0.0%	0.0%	0.0%	0.0%	0.0%	0.0%	0.0%	0.0%	0.0%	0.0%	0.0%	0.0%	0.0%	0.0%	0.0%	0.0%	0.0%	0.0%	0.0%	0.0%	0.0%	0.0%	

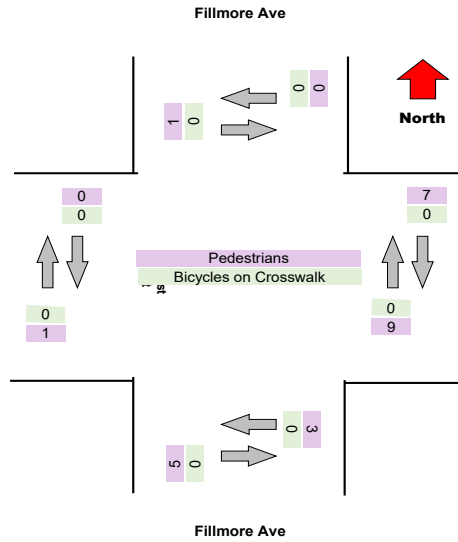
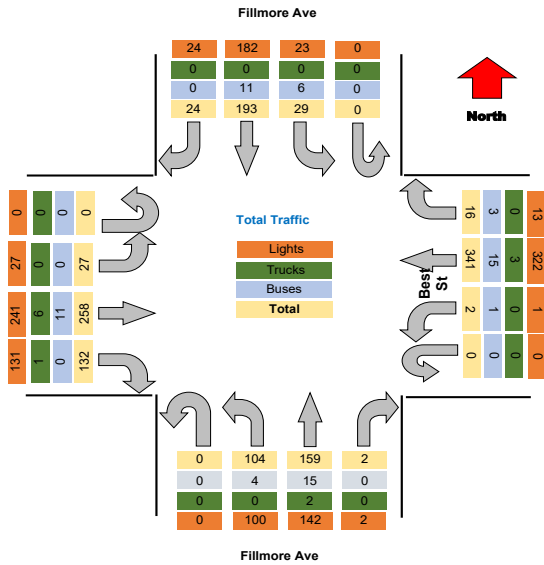



### Turning Movement Peak Hour Data (PM)

4:30:00 PM

Leg Direction	Fillmore Ave						Best St						Fillmore Ave						Best St						Total					
	Southbound			Northbound			Westbound			Eastbound			Northbound			Eastbound														
Start Time	Right	Thru	Left	U-Turn	App Total	Peds CW	Peds CCW	Right	Thru	Left	U-Turn	App Total	Peds CW	Peds CCW	Right	Thru	Left	U-Turn	App Total	Peds CW	Peds CCW	Right	Thru	Left	U-Turn	App Total	Peds CW	Peds CCW		
4:30:00 PM	8	60	7	0	75	0	0	11	82	1	0	94	0	1	4	64	27	0	95	0	1	25	149	8	0	182	1	0	446	
4:45:00 PM	7	66	9	0	82	0	0	3	79	1	0	83	0	2	1	73	33	0	107	0	0	35	118	4	0	151	0	0	423	
5:00:00 PM	7	50	11	0	68	0	0	7	79	2	0	88	1	0	0	48	30	0	78	0	0	29	118	8	0	155	1	0	389	
5:15:00 PM	2	48	3	0	53	0	0	7	62	0	0	69	0	2	1	50	36	0	87	0	1	26	91	8	0	125	0	0	354	
<b>Grand Total</b>	<b>24</b>	<b>224</b>	<b>30</b>	<b>0</b>	<b>278</b>	<b>0</b>	<b>0</b>	<b>28</b>	<b>322</b>	<b>4</b>	<b>0</b>	<b>354</b>	<b>1</b>	<b>6</b>	<b>6</b>	<b>235</b>	<b>126</b>	<b>0</b>	<b>367</b>	<b>0</b>	<b>2</b>	<b>115</b>	<b>470</b>	<b>28</b>	<b>0</b>	<b>613</b>	<b>2</b>	<b>0</b>	<b>1612</b>	
% Approach	8.6%	89.6%	10.8%	0.0%	0.0%	0.0%	0.0%	14.2%	85.8%	0.0%	0.0%	0.0%	0.0%	0.0%	45.1%	41.7%	13.2%	0.0%	0.0%	0.0%	0.0%	0.0%	66.2%	33.8%	0.0%	0.0%	0.0%	0.0%	0.0%	
% Total	1.5%	13.9%	1.9%	0.0%	17.2%	0.0%	0.0%	1.7%	20.0%	0.2%	0.0%	22.0%	0.0%	0.0%	0.4%	14.6%	7.8%	0.0%	22.8%	0.0%	0.0%	7.1%	29.2%	1.7%	0.0%	38.0%	0.0%	0.0%	0.0%	
PHF	0.750	0.848	0.682	0.000	0.848	0.000	0.000	0.636	0.982	0.500	0.000	0.941	0.000	0.000	0.375	0.805	0.875	0.000	0.857	0.000	0.000	0.821	0.789	0.875	0.000	0.842	0.000	0.000	0.904	
Lights	24	214	29	0	267	0	0	27	316	3	0	346	0	0	6	222	125	0	353	0	0	113	451	26	0	590	0	0	1566	
% Lights	100.0%	95.5%	96.7%	0.0%	96.0%	0.0%	0.0%	96.4%	98.1%	75.0%	0.0%	97.7%	0.0%	0.0%	100.0%	94.5%	99.2%	0.0%	96.2%	0.0%	0.0%	98.3%	96.0%	92.9%	0.0%	96.2%	0.0%	0.0%	96.5%	
Trucks	0	1	0	0	1	0	0	0	1	0	0	1	0	0	0	1	0	0	1	0	0	1	0	0	0	1	0	0	4	
% Trucks	0.0%	0.4%	0.0%	0.0%	0.4%	0.0%	0.0%	0.0%	0.3%	0.0%	0.0%	0.3%	0.0%	0.0%	0.0%	0.4%	0.0%	0.0%	0.3%	0.0%	0.0%	0.9%	0.0%	0.0%	0.0%	0.2%	0.0%	0.0%	0.2%	
Buses	0	9	1	0	10	0	0	1	5	1	0	7	0	0	0	12	1	0	13	0	0	1	19	2	0	22	0	0	52	
% Buses	0.0%	4.0%	3.3%	0.0%	3.6%	0.0%	0.0%	3.6%	1.6%	25.0%	0.0%	2.0%	0.0%	0.0%	0.0%	5.1%	0.8%	0.0%	3.6%	0.0%	0.0%	0.9%	4.0%	7.1%	0.0%	3.6%	0.0%	0.0%	3.2%	
Pedestrians	0	0	0	0	0	0	0	0	0	0	0	0	5	0	0	0	0	0	0	2	0	0	0	0	0	0	2	0	0	
% Pedestrians	0.0%	0.0%	0.0%	0.0%	0.0%	100.0%	100.0%	0.0%	0.0%	0.0%	0.0%	0.0%	100.0%	100.0%	0.0%	0.0%	0.0%	0.0%	0.6%	0.0%	0.0%	0.0%	0.0%	0.0%	0.0%	0.0%	0.6%	100.0%	0.0%	0.0%
Bicycles on Crosswalk	0	0	0	0	0	0	0	0	0	0	0	0	1	0	0	0	0	0	0	0	0	0	0	0	0	0	0	0	0	
% Bicycles on Crosswalk	0.0%	0.0%	0.0%	0.0%	0.0%	0.0%	0.0%	0.0%	0.0%	0.0%	0.0%	0.0%	100.0%	100.0%	0.0%	0.0%	0.0%	0.0%	0.0%	0.0%	0.0%	0.0%	0.0%	0.0%	0.0%	0.0%	0.0%	0.0%	0.0%	

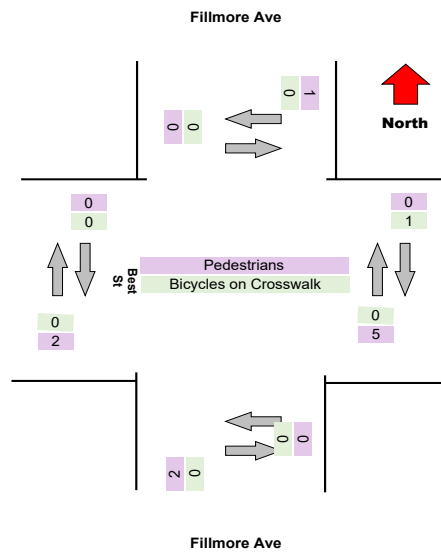
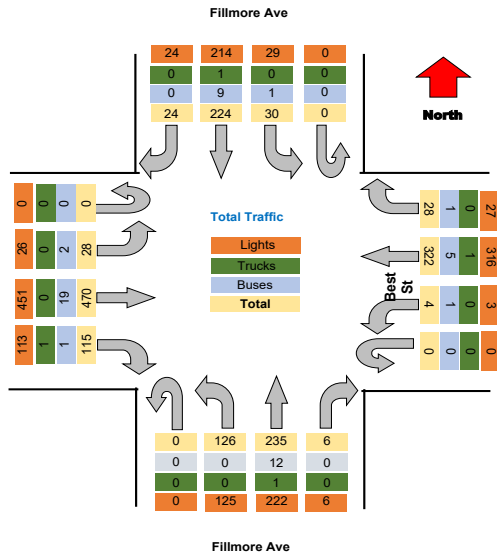



Project : VBH Malta NY  
 Site : Site 4  
 Location : 42.948550, -73.790036

TSTData.com

Survey Date : 2021-04-28, Wednesday

Project	Labella
Project Code	Labella
Site Name	16
Legs and Movements	All Processed Legs & Move
Bin Size	15 minutes
Survey Date	2021-10-27, Wednesday
Location	16
Latitude and Longitude	42.903669, -78.839296

	Start	End	PHF
Forced Peak AM	2021/10/27 07:30:00	2021/10/27 08:30:00	0.93
Forced Peak PM	2021/10/27 16:30:00	2021/10/27 17:30:00	0.93
AM Peak	2021/10/27 07:30:00	2021/10/27 08:30:00	0.93
PM Peak	2021/10/27 16:30:00	2021/10/27 17:30:00	0.93

### Turning Movement Data

Leg Direction	Fillmore Ave										Best St										Fillmore Ave										Best St										Total
	Southbound					Westbound					Northbound					Eastbound					Northbound					Eastbound															
	Right	Thru	Left	U-Turn	App Total	Right	Thru	Left	U-Turn	App Total	Right	Thru	Left	U-Turn	App Total	Right	Thru	Left	U-Turn	App Total	Right	Thru	Left	U-Turn	App Total	Right	Thru	Left	U-Turn	App Total											
6:30:00 AM	3	19	0	0	22	1	46	1	0	48	0	12	4	0	16	15	32	3	0	50	0	0	0	0	0	0	0	0	0	0	136										
6:45:00 AM	1	28	0	0	29	1	88	1	0	90	0	23	11	0	34	14	20	4	0	38	0	0	0	0	0	0	0	0	0	0	171										
Hourly Total	4	47	0	0	51	2	134	2	0	136	0	35	15	0	50	29	52	7	0	88	0	0	0	0	0	0	0	0	0	0	307										
7:00:00 AM	3	33	1	0	37	2	36	2	0	40	1	23	12	0	36	16	25	4	0	45	0	0	0	0	0	0	0	0	0	0	164										
7:15:00 AM	2	23	1	0	26	5	61	2	0	68	4	24	15	0	43	19	37	6	0	62	0	0	0	0	0	0	0	0	0	0	204										
7:30:00 AM	8	31	2	0	41	1	82	0	0	83	3	24	15	0	42	2	39	20	0	61	2	4	0	0	6	31	52	7	0	90	0	0	0	0	285						
7:45:00 AM	3	53	3	0	59	1	98	0	0	99	3	24	15	0	42	2	39	20	0	61	2	4	0	0	6	31	52	7	0	90	0	0	0	0	359						
Hourly Total	16	140	7	0	163	13	277	4	0	294	11	16	8	0	25	8	135	74	0	217	9	97	191	21	0	309	0	0	0	0	0	1012									
8:00:00 AM	6	57	6	0	69	3	83	1	0	87	0	0	38	26	64	4	1	33	80	119	2	0	33	72	5	0	110	2	0	33	72	5	0	359							
8:15:00 AM	5	51	12	0	68	6	97	0	0	103	1	0	0	39	39	0	1	33	72	110	2	0	33	72	5	0	110	2	0	33	72	5	0	360							
Hourly Total	11	108	18	0	137	9	180	1	0	190	1	0	77	65	143	4	2	66	152	229	4	0	66	152	11	0	229	4	0	66	152	11	0	699							
4:00:00 PM	19	86	3	0	108	4	91	1	0	96	4	1	3	50	58	3	0	28	114	14	0	3	28	114	14	0	156	0	3	28	114	14	0	449							
4:15:00 PM	10	63	7	0	80	8	98	0	0	106	2	1	0	67	29	0	1	37	107	7	0	151	3	0	151	3	0	151	3	0	433										
4:30:00 PM	11	48	3	0	62	8	94	1	0	103	4	0	2	66	37	0	105	0	42	116	13	0	42	116	13	0	171	0	4	42	116	13	0	441							
4:45:00 PM	10	64	4	0	78	6	83	0	0	89	0	1	0	50	41	0	91	1	39	98	8	0	39	98	8	0	145	0	0	39	98	8	0	403							
Hourly Total	50	261	17	0	328	0	26	368	2	394	10	3	5	233	143	3	5	146	435	42	0	7	146	435	42	0	623	3	7	146	435	42	0	1726							
5:00:00 PM	14	64	9	0	87	8	98	0	0	103	1	2	51	34	87	0	0	32	95	8	0	126	0	0	126	0	0	126	0	0	402										
5:15:00 PM	9	44	9	0	62	7	101	0	0	108	0	1	47	30	78	2	0	37	95	7	0	139	0	1	139	0	1	139	0	1	387										
5:30:00 PM	12	64	4	0	80	7	86	0	0	93	3	0	0	44	43	0	87	0	29	100	5	0	29	100	5	0	134	1	0	29	100	5	0	394							
5:45:00 PM	9	40	6	0	55	4	81	1	0	86	0	1	38	36	75	0	0	23	79	6	0	108	0	0	108	0	0	108	0	0	324										
Hourly Total	44	212	28	0	284	26	363	1	0	390	3	1	4	180	143	0	327	2	121	359	26	0	121	359	26	0	506	1	1	121	359	26	0	1507							
Grand Total	125	788	70	0	963	76	1300	10	0	1388	25	20	17	660	440	0	1145	14	459	1189	107	0	1755	8	8	1755	8	8	5281												
% Approach	13.0%	79.8%	7.3%	0.0%	0.0%	5.5%	93.7%	0.7%	0.0%	0.0%	0.0%	0.0%	1.5%	57.6%	38.4%	0.0%	0.0%	26.2%	67.7%	6.1%	0.0%	0.0%	0.0%	0.0%	0.0%	0.0%	0.0%	0.0%	0.0%	0.0%											
% Total	2.4%	14.6%	1.3%	0.0%	18.3%	1.4%	24.8%	0.2%	0.0%	26.4%	0.0%	0.0%	0.3%	12.6%	8.4%	0.0%	21.8%	8.7%	22.6%	2.0%	0.0%	0.0%	33.4%	0.0%	0.0%	0.0%	0.0%	0.0%	0.0%												
Lights	123	717	64	0	904	86	1210	8	0	1284	0	0	17	607	434	0	1088	451	1117	97	0	1665	0	0	1665	0	0	4911													
% Lights	98.4%	93.4%	91.4%	0.0%	93.9%	86.8%	93.1%	80.0%	0.0%	92.9%	0.0%	0.0%	100.0%	92.0%	98.8%	0.0%	92.4%	98.3%	93.9%	90.7%	0.0%	94.9%	0.0%	0.0%	94.9%	0.0%	0.0%	93.9%													
Trucks	0	1	0	0	1	0	7	0	0	7	0	0	0	3	1	0	4	1	8	0	0	9	0	0	9	0	0	21													
% Trucks	0.0%	0.1%	0.0%	0.0%	0.1%	0.0%	0.5%	0.0%	0.0%	0.5%	0.0%	0.0%	0.0%	0.5%	0.2%	0.0%	0.3%	0.2%	0.7%	0.0%	0.0%	0.5%	0.0%	0.0%	0.5%	0.0%	0.0%	0.4%													
Buses	2	47	6	0	55	10	83	2	0	95	0	0	0	48	5	0	53	5	63	10	0	78	0	0	78	0	0	281													
% Buses	1.6%	6.1%	8.6%	0.0%	0.0%	0.0%	6.4%	20.0%	0.0%	0.0%	0.0%	0.0%	0.0%	7.3%	1.1%	0.0%	0.0%	1.1%	5.3%	9.3%	0.0%	0.0%	0.0%	0.0%	0.0%	0.0%	0.0%	5.4%													
Pedestrians	0	0	0	0	0	0	0	0	0	0	25	17	0	0	0	0	14	0	0	0	0	7	0	0	7	0	0	0													
% Pedestrians	0.0%	0.0%	0.0%	0.0%	0.0%	0.0%	0.0%	0.0%	0.0%	0.0%	100.0%	85.0%	0.0%	0.0%	0.0%	0.0%	100.0%	0.0%	0.0%	0.0%	0.0%	0.0%	0.0%	0.0%	0.0%	0.0%	87.5%	87.5%													
Bicycles on Crosswalk	0	0	0	0	0	0	0	0	0	0	0	3	0	0	0	0	0	0	0	0	0	1	0	1	1	0	0	0													
% Bicycles on Crosswalk	0.0%	0.0%	0.0%	0.0%	0.0%	0.0%	0.0%	0.0%	0.0%	0.0%	0.0%	15.0%	0.0%	0.0%	0.0%	0.0%	0.0%	0.0%	0.0%	0.0%	0.0%	0.0%	0.0%	0.0%	0.0%	0.0%	12.5%	12.5%													

Project : VBH Malta NY  
 Site : Site 4  
 Location : 42.948550, -73.790036  
 Survey Date : 2021-04-28, Wednesday

### Turning Movement Data Plot

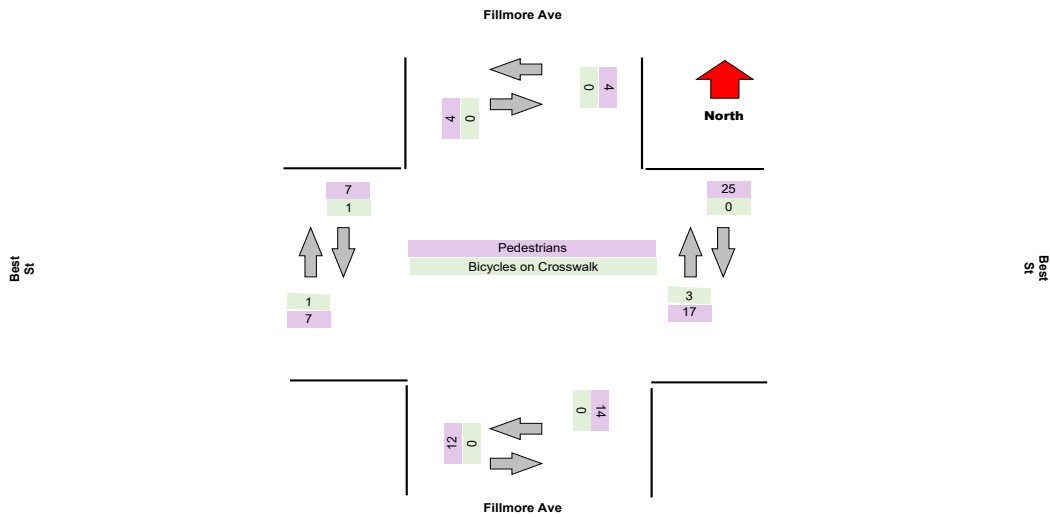
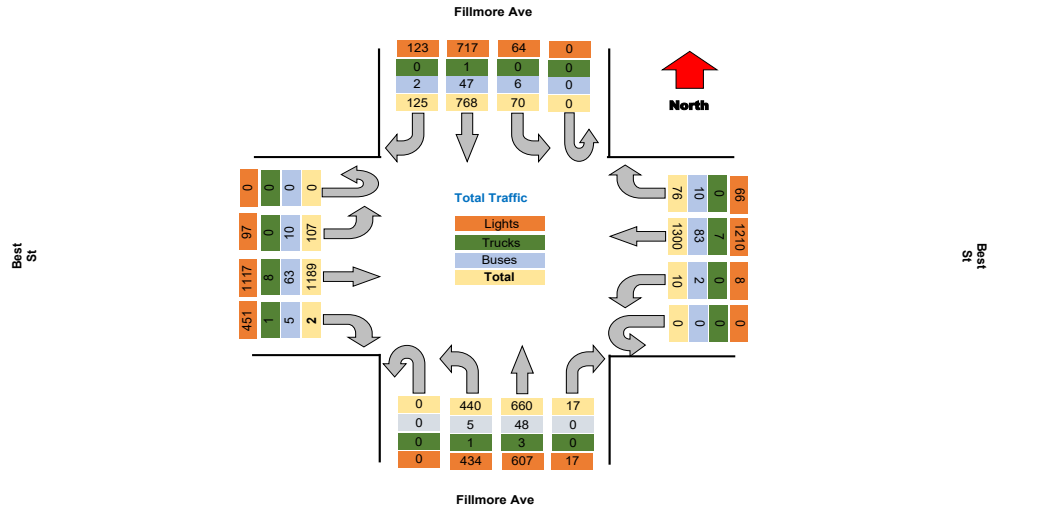

Project : VBH Malta NY  
Site : Site 4  
Location : 42.948550, -73.790036

TSTData.com

Survey Date : 2021-04-28, Wednesday

### Turning Movement Peak Hour Data (AM)

7:30:00 AM

Leg Direction	Fillmore Ave								Best St								Fillmore Ave								Best St								Total
	Southbound				Westbound				Northbound				Eastbound				Northbound				Eastbound												
Start Time	Right	Thru	Left	U-Turn	App Total	Peds CW	Peds CCW	Right	Thru	Left	U-Turn	App Total	Peds CW	Peds CCW	Right	Thru	Left	U-Turn	App Total	Peds CW	Peds CCW	Right	Thru	Left	U-Turn	App Total	Peds CW	Peds CCW					
7:30:00 AM	8	31	2	0	41	1	1	1	82	0	0	84	3	6	2	39	20	0	70	2	4	31	52	7	0	90	0	0	285				
7:45:00 AM	3	53	3	0	59	1	1	5	98	0	0	104	3	3	2	49	27	0	84	1	1	31	77	4	0	112	0	0	359				
8:00:00 AM	6	57	6	0	69	0	0	3	83	1	0	87	0	0	0	38	26	0	64	4	1	33	90	6	0	119	2	0	339				
8:15:00 AM	5	51	12	0	68	0	0	6	87	0	0	103	1	0	0	39	39	0	79	0	1	33	72	5	0	110	2	0	360				
<b>Grand Total</b>	<b>22</b>	<b>192</b>	<b>23</b>	<b>0</b>	<b>237</b>	<b>2</b>	<b>2</b>	<b>15</b>	<b>360</b>	<b>1</b>	<b>0</b>	<b>378</b>	<b>7</b>	<b>9</b>	<b>4</b>	<b>155</b>	<b>112</b>	<b>0</b>	<b>297</b>	<b>7</b>	<b>7</b>	<b>128</b>	<b>281</b>	<b>22</b>	<b>0</b>	<b>431</b>	<b>4</b>	<b>0</b>	<b>1343</b>				
% Approach	9.3%	81.0%	9.7%	0.0%	0.0%	0.0%	0.0%	14.2%	85.8%	0.0%	0.0%	0.0%	0.0%	0.0%	45.1%	41.7%	13.2%	0.0%	0.0%	0.0%	0.0%	0.0%	66.2%	33.8%	0.0%	0.0%	0.0%	0.0%	0.0%				
% Total	1.6%	14.3%	1.7%	0.0%	17.6%	0.0%	0.0%	1.1%	26.8%	0.1%	0.0%	28.1%	0.0%	0.0%	0.3%	12.3%	8.3%	0.0%	22.1%	0.0%	0.0%	9.5%	20.9%	1.6%	0.0%	32.1%	0.0%	0.0%	0.0%				
PHF	0.688	0.842	0.479	0.000	0.859	0.000	0.000	0.625	0.918	0.250	0.000	0.909	0.000	0.000	0.500	0.842	0.718	0.000	0.884	0.000	0.000	0.970	0.878	0.786	0.000	0.905	0.000	0.000	0.933				
Lights	21	177	17	0	215	0	0	11	338	1	0	350	0	0	4	147	109	0	260	0	0	127	265	22	0	414	0	0	1239				
% Trucks	0.0%	0.0%	0.0%	0.0%	0.0%	0.0%	0.0%	0.0%	1.7%	0.0%	0.0%	1.6%	0.0%	0.0%	0.0%	0.6%	0.0%	0.0%	0.3%	0.0%	0.0%	0.0%	1.8%	0.0%	0.0%	1.2%	0.0%	0.0%	0.9%				
Buses	1	14	6	0	21	0	0	4	16	0	0	20	0	0	0	17	3	0	20	0	0	1	11	0	0	12	0	0	73				
% Buses	4.5%	7.3%	26.1%	0.0%	0.0%	0.0%	0.0%	28.7%	4.4%	0.0%	0.0%	0.0%	0.0%	0.0%	0.0%	10.3%	2.7%	0.0%	0.0%	0.0%	0.0%	0.8%	3.9%	0.0%	0.0%	0.0%	0.0%	0.0%	5.4%				
Pedestrians	0	0	0	0	0	2	2	0	0	0	0	7	8	0	0	0	0	0	7	7	0	0	0	0	0	0	4	0	0				
% Pedestrians	0.0%	0.0%	0.0%	0.0%	0.0%	100.0%	100.0%	0.0%	0.0%	0.0%	0.0%	0.0%	100.0%	88.9%	0.0%	0.0%	0.0%	0.0%	0.0%	0.0%	0.0%	0.0%	0.0%	0.0%	0.0%	0.0%	0.0%	100.0%	0.0%				
Bicycles on Crosswalk	0	0	0	0	0	0	0	0	0	0	0	0	1	0	0	0	0	0	0	0	0	0	0	0	0	0	0	0	0				
% Bicycles on Crosswalk	0.0%	0.0%	0.0%	0.0%	0.0%	0.0%	0.0%	0.0%	0.0%	0.0%	0.0%	0.0%	0.0%	11.1%	0.0%	0.0%	0.0%	0.0%	0.0%	0.0%	0.0%	0.0%	0.0%	0.0%	0.0%	0.0%	0.0%	0.0%	0.0%				

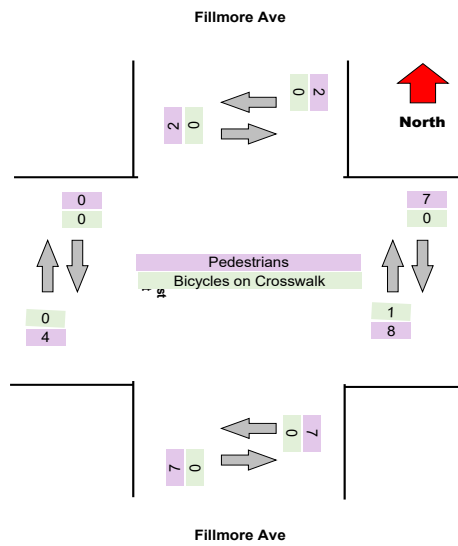
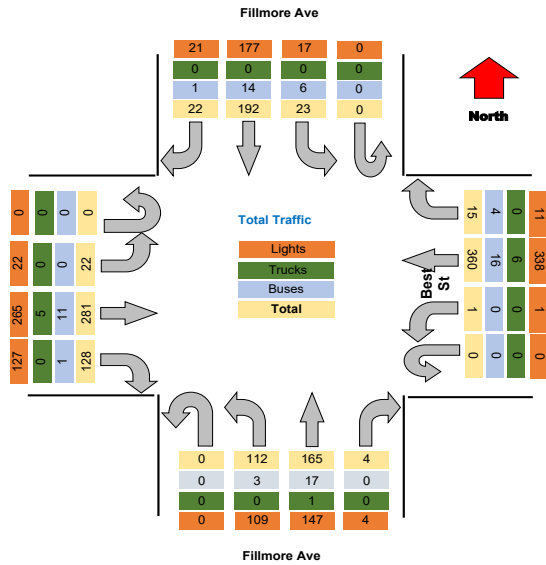

Project : VBH Malta NY  
Site : Site 4  
Location : 42.948550, -73.790036

TSTData.com

Survey Date : 2021-04-28, Wednesday

### Turning Movement Peak Hour Data (PM)

4:30:00 PM

Leg Direction	Fillmore Ave						Best St						Fillmore Ave						Best St						Total				
	Southbound			Westbound			Northbound			Eastbound			Northbound			Eastbound													
Start Time	Right	Thru	Left	U-Turn	App Total	Peds CW	Peds CCW	Right	Thru	Left	U-Turn	App Total	Peds CW	Peds CCW	Right	Thru	Left	U-Turn	App Total	Peds CW	Peds CCW	Right	Thru	Left	U-Turn	App Total	Peds CW	Peds CCW	
4:30:00 PM	11	48	3	0	62	0	1	8	94	1	0	103	4	0	2	66	37	0	105	0	0	42	116	13	0	171	0	4	441
4:45:00 PM	10	64	4	0	78	0	0	6	83	0	0	89	0	1	0	50	41	0	91	1	0	39	98	8	0	145	0	0	403
5:00:00 PM	14	64	9	0	87	0	0	8	95	0	0	103	0	1	2	51	34	0	87	0	0	32	85	8	0	125	0	0	402
5:15:00 PM	9	44	9	0	62	0	0	7	101	0	0	108	0	0	1	47	30	0	78	2	0	37	85	7	0	139	0	1	387
<b>Grand Total</b>	<b>44</b>	<b>220</b>	<b>25</b>	<b>0</b>	<b>289</b>	<b>0</b>	<b>1</b>	<b>29</b>	<b>373</b>	<b>1</b>	<b>0</b>	<b>423</b>	<b>4</b>	<b>1</b>	<b>5</b>	<b>214</b>	<b>142</b>	<b>0</b>	<b>361</b>	<b>3</b>	<b>0</b>	<b>150</b>	<b>394</b>	<b>36</b>	<b>0</b>	<b>580</b>	<b>3</b>	<b>5</b>	<b>1633</b>
% Approach	15.2%	76.1%	8.7%	0.0%	0.0%	0.0%	0.0%	14.2%	85.8%	0.0%	0.0%	0.0%	0.0%	0.0%	45.1%	41.7%	13.2%	0.0%	0.0%	0.0%	0.0%	0.0%	66.2%	33.8%	0.0%	0.0%	0.0%	0.0%	0.0%
% Total	2.7%	13.5%	1.5%	0.0%	17.7%	0.0%	0.0%	1.8%	22.8%	0.1%	0.0%	24.7%	0.0%	0.0%	0.3%	13.1%	8.7%	0.0%	22.1%	0.0%	0.0%	9.2%	24.1%	2.2%	0.0%	35.5%	0.0%	0.0%	
PHF	0.786	0.859	0.694	0.000	0.830	0.000	0.000	0.906	0.923	0.250	0.000	0.933	0.000	0.000	0.625	0.811	0.866	0.000	0.860	0.000	0.000	0.893	0.849	0.692	0.000	0.848	0.000	0.000	0.926
Lights	44	206	25	0	275	0	0	28	365	1	0	394	0	0	5	204	141	0	350	0	0	147	374	32	0	553	0	0	1572
% Lights	100.0%	93.6%	100.0%	0.0%	95.2%	0.0%	0.0%	96.6%	97.9%	100.0%	0.0%	97.8%	0.0%	0.0%	100.0%	95.3%	99.3%	0.0%	97.0%	0.0%	0.0%	98.0%	94.9%	88.9%	0.0%	95.3%	0.0%	0.0%	96.3%
Trucks	0	1	0	0	1	0	0	0	1	0	0	1	0	0	0	1	0	0	1	0	0	1	0	0	0	1	0	0	4
% Trucks	0.0%	0.5%	0.0%	0.0%	0.3%	0.0%	0.0%	0.0%	0.3%	0.0%	0.0%	0.2%	0.0%	0.0%	0.0%	0.5%	0.0%	0.0%	0.3%	0.0%	0.0%	0.7%	0.0%	0.0%	0.0%	0.2%	0.0%	0.0%	0.2%
Buses	0	12	0	0	12	0	0	1	7	0	0	8	0	0	0	9	1	0	10	0	0	1	20	4	0	25	0	0	56
% Buses	0.0%	5.5%	0.0%	0.0%	0.0%	0.0%	0.0%	3.4%	1.9%	0.0%	0.0%	0.0%	0.0%	0.0%	0.0%	4.2%	0.7%	0.0%	0.0%	0.0%	0.0%	0.7%	5.1%	11.1%	0.0%	0.0%	0.0%	0.0%	3.4%
Pedestrians	0	0	0	0	0	1	0	0	0	0	0	4	1	0	0	0	0	0	3	0	0	0	0	0	0	0	0	5	0
% Pedestrians	0.0%	0.0%	0.0%	0.0%	0.0%	100.0%	0.0%	0.0%	0.0%	0.0%	0.0%	0.0%	100.0%	50.0%	0.0%	0.0%	0.0%	0.0%	0.0%	0.0%	100.0%	0.0%	0.0%	0.0%	0.0%	0.0%	0.0%	100.0%	0.0%
Bicycles on Crosswalk	0	0	0	0	0	0	0	0	0	0	0	0	1	0	0	0	0	0	0	0	0	0	0	0	0	0	0	0	0
% Bicycles on Crosswalk	0.0%	0.0%	0.0%	0.0%	0.0%	0.0%	0.0%	0.0%	0.0%	0.0%	0.0%	0.0%	0.0%	50.0%	0.0%	0.0%	0.0%	0.0%	0.0%	0.0%	0.0%	0.0%	0.0%	0.0%	0.0%	0.0%	0.0%	0.0%	0.0%

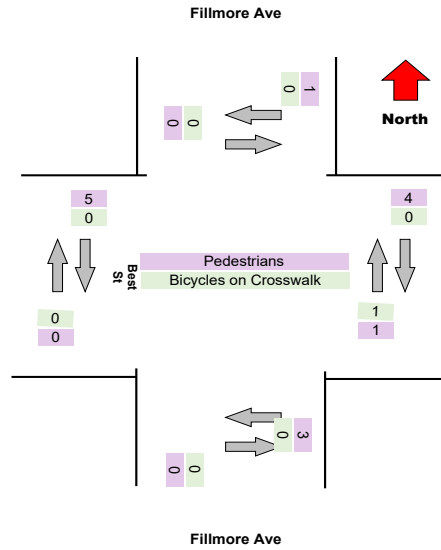
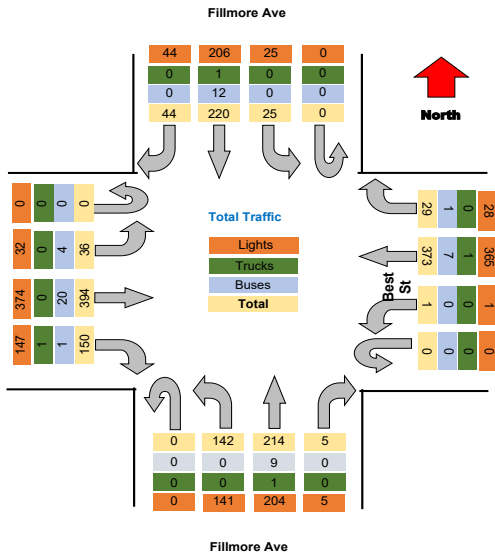

Project : VBH Malta NY  
 Site : Site 4  
 Location : 42.948550, -73.790036

TSTData.com

Survey Date : 2021-04-28, Wednesday

Project	Labella
Project Code	Labella
Site Name	16
Legs and Movements	All Processed Legs & Move
Bin Size	15 minutes
Survey Date	2021-10-28, Thursday
Location	16
Latitude and Longitude	42.903669, -78.839296

	Start	End	PHF
Forced Peak AM	2021/10/28 07:30:00	2021/10/28 08:30:00	0.85
Forced Peak PM	2021/10/28 16:30:00	2021/10/28 17:30:00	0.96
AM Peak	2021/10/28 07:30:00	2021/10/28 08:30:00	0.85
PM Peak	2021/10/28 16:30:00	2021/10/28 17:30:00	0.96

### Turning Movement Data

Leg Direction	Fillmore Ave							Best St							Fillmore Ave							Best St							Total	
	Southbound				Westbound			Northbound				Eastbound			Southbound				Westbound			Northbound				Eastbound				
	Right	Thru	Left	U-Turn	App Total	Peds CV	Peds CCV	Right	Thru	Left	U-Turn	App Total	Peds CV	Peds CCV	Right	Thru	Left	U-Turn	App Total	Peds CV	Peds CCV	Right	Thru	Left	U-Turn	App Total	Peds CV	Peds CCV		
Start Time																														
6:30:00 AM	2	12	1	0	15	0	0	1	45	0	0	46	0	0	0	10	8	0	18	0	0	6	31	2	2	0	39	0	0	118
6:45:00 AM	0	23	0	0	23	0	0	3	61	0	0	64	4	0	0	20	10	0	34	0	0	18	43	8	0	0	69	0	0	190
Hourly Total	2	35	1	0	38	0	0	4	106	0	0	110	4	0	0	30	18	0	52	0	0	24	74	10	2	0	108	0	0	308
7:00:00 AM	9	19	0	0	28	0	0	2	51	0	0	53	1	1	0	13	6	0	21	0	3	13	30	4	0	0	47	0	1	149
7:15:00 AM	5	24	2	0	31	0	0	3	52	0	0	55	4	2	1	22	13	0	42	0	1	16	50	9	0	0	75	0	0	203
7:30:00 AM	7	32	1	0	40	0	1	3	73	1	0	78	1	3	2	61	19	0	86	0	3	22	48	2	0	0	72	0	1	276
7:45:00 AM	9	51	0	0	60	2	0	3	95	0	0	98	3	5	1	46	25	0	80	0	1	40	87	10	0	0	117	0	0	355
Hourly Total	30	126	3	0	159	2	1	11	271	1	0	284	9	11	4	142	63	0	229	0	8	91	195	25	0	0	311	0	2	893
8:00:00 AM	13	64	6	0	83	2	1	4	87	0	0	92	0	3	1	45	36	0	86	1	4	31	100	16	0	0	147	0	0	407
8:15:00 AM	8	54	9	0	71	2	1	3	80	1	0	85	1	0	3	37	27	0	68	2	0	40	70	6	0	0	116	0	0	340
Hourly Total	21	118	15	0	154	4	2	7	167	1	0	177	1	3	4	82	63	0	153	3	4	71	170	22	0	0	263	0	0	747
4:00:00 PM	12	68	6	0	86	1	4	12	91	0	0	103	0	0	2	45	44	0	91	0	1	34	97	10	1	0	142	0	1	422
4:15:00 PM	7	56	13	0	76	1	0	12	91	1	0	104	0	2	2	50	51	0	103	0	1	44	124	13	0	0	181	0	1	464
4:30:00 PM	13	61	7	0	81	0	2	6	102	0	0	108	0	0	0	55	45	0	100	0	2	32	108	10	0	0	150	0	0	439
4:45:00 PM	9	59	15	0	82	1	0	4	94	0	0	99	3	0	3	68	43	0	114	2	3	37	100	7	0	0	144	1	0	438
Hourly Total	41	243	41	0	325	3	6	34	378	1	0	413	3	2	7	218	183	0	408	2	7	147	429	40	1	0	617	1	2	1763
5:00:00 PM	7	46	14	0	67	3	0	12	80	0	0	92	0	3	1	50	26	0	77	2	0	26	110	6	0	0	142	0	0	378
5:15:00 PM	16	65	8	0	89	0	0	6	96	1	0	103	1	0	1	56	33	0	90	1	0	33	100	11	0	0	144	0	0	426
5:30:00 PM	16	61	9	0	86	1	0	9	101	1	0	111	1	0	3	51	33	0	87	0	1	41	101	8	0	0	150	0	0	434
5:45:00 PM	12	48	4	0	64	4	0	6	90	0	0	96	0	1	0	40	34	0	74	0	0	37	82	5	0	0	124	0	2	358
Hourly Total	51	220	35	0	306	8	0	33	367	2	0	402	2	4	5	197	126	0	328	3	1	137	393	30	0	0	560	0	2	1596
Grand Total	145	742	95	0	982	17	9	89	1289	5	0	1386	16	20	20	669	453	0	1170	8	20	470	1281	127	1	0	1899	1	6	5397
% Approach	14.8%	75.6%	8.7%	0.0%	0.0%	0.0%	0.0%	6.4%	93.0%	0.4%	0.0%	0.0%	0.0%	0.0%	1.7%	57.2%	38.7%	0.0%	0.0%	0.0%	0.0%	25.3%	67.8%	6.8%	0.1%	0.0%	0.0%	0.0%	0.0%	0.0%
% Total	2.7%	13.7%	1.8%	0.0%	18.2%	0.0%	0.0%	1.6%	23.9%	0.1%	0.0%	25.7%	0.0%	0.0%	0.4%	12.4%	8.4%	0.0%	21.7%	0.0%	0.0%	8.7%	23.4%	2.4%	0.0%	0.0%	34.4%	0.0%	0.0%	0.0%
Lights	141	694	91	0	926	0	0	82	1206	4	0	1292	0	0	19	614	445	0	1078	0	0	460	1192	116	1	0	1769	0	0	5065
% Lights	97.2%	93.5%	95.9%	0.0%	94.2%	0.0%	0.0%	52.1%	93.6%	80.0%	0.0%	93.2%	0.0%	0.0%	95.0%	91.8%	98.2%	0.0%	92.1%	0.0%	0.0%	97.9%	94.5%	91.3%	###	###	95.2%	0.0%	0.0%	93.9%
Trucks	2	2	0	0	4	0	0	1	3	0	0	4	0	0	0	1	3	0	4	0	0	2	5	2	0	0	9	0	0	21
% Trucks	1.4%	0.3%	0.0%	0.0%	0.4%	0.0%	0.0%	1.1%	0.2%	0.0%	0.0%	0.3%	0.0%	0.0%	0.0%	0.1%	0.7%	0.0%	0.3%	0.0%	0.0%	0.4%	0.4%	1.6%	0.0%	0.0%	0.5%	0.0%	0.0%	0.4%
Buses	1	46	4	0	51	0	0	6	79	1	0	86	0	0	1	47	4	0	52	0	0	6	82	9	0	0	77	0	0	266
% Buses	0.7%	6.2%	4.2%	0.0%	0.0%	0.0%	0.0%	0.0%	6.1%	20.0%	0.0%	0.0%	0.0%	0.0%	5.0%	7.0%	0.9%	0.0%	0.0%	0.0%	0.0%	1.3%	4.9%	7.1%	0.0%	0.0%	0.0%	0.0%	0.0%	4.9%
Pedestrians	0	0	0	0	0	17	9	0	0	0	0	0	18	15	0	0	0	0	0	8	12	0	0	0	0	0	0	1	4	0
% Pedestrians	0.0%	0.0%	0.0%	0.0%	0.0%	100.0%	100.0%	0.0%	0.0%	0.0%	0.0%	0.0%	94.7%	75.0%	0.0%	0.0%	0.0%	0.0%	0.0%	100.0%	60.0%	0.0%	0.0%	0.0%	0.0%	0.0%	0.0%	100.0%	66.7%	0.0%
Bicycles on Crosswalk	0	0	0	0	0	0	0	0	0	0	0	0	1	5	0	0	0	0	0	0	8	0	0	0	0	0	0	0	2	0
% Bicycles on Crosswalk	0.0%	0.0%	0.0%	0.0%	0.0%	0.0%	0.0%	0.0%	0.0%	0.0%	0.0%	0.0%	5.3%	25.0%	0.0%	0.0%	0.0%	0.0%	0.0%	0.0%	40.0%	0.0%	0.0%	0.0%	0.0%	0.0%	0.0%	0.0%	33.3%	0.0%

Project : VBH Malta NY  
 Site : Site 4  
 Location : 42.948550, -73.790036  
 Survey Date : 2021-04-28, Wednesday

### Turning Movement Data Plot

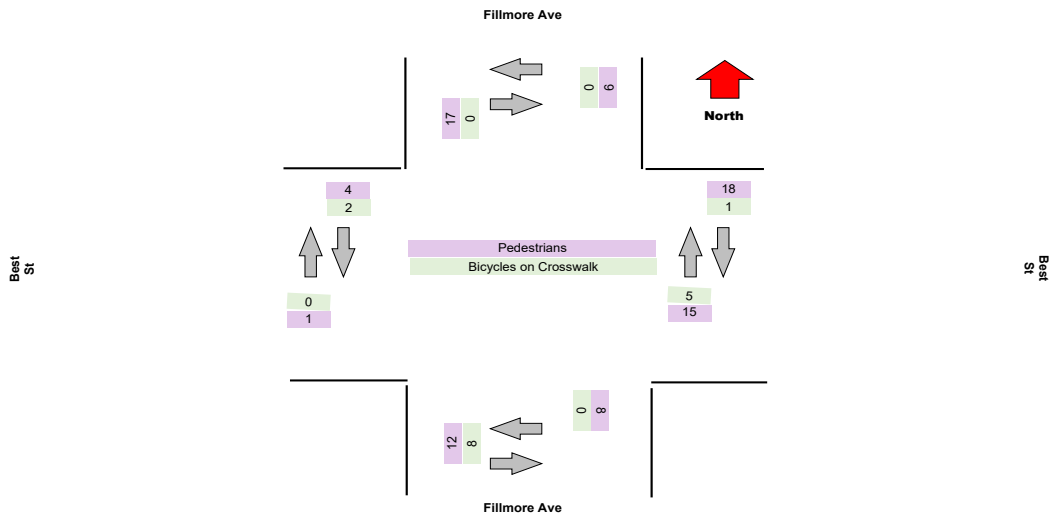
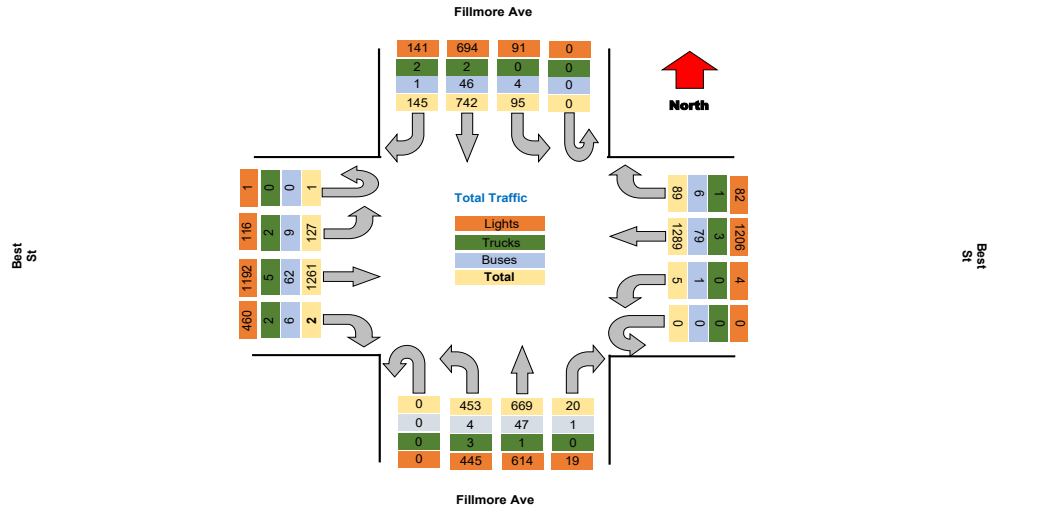

**Turning Movement Peak Hour Data (AM)**

7:30:00 AM

Leg Direction	Fillmore Ave						Best St						Fillmore Ave						Best St						Total					
	Southbound			Westbound			Northbound			Eastbound			Northbound			Eastbound														
Start Time	Right	Thru	Left	U-Turn	App Total	Peds CW	Peds CCW	Right	Thru	Left	U-Turn	App Total	Peds CW	Peds CCW	Right	Thru	Left	U-Turn	App Total	Peds CW	Peds CCW	Right	Thru	Left	U-Turn	App Total	Peds CW	Peds CCW		
7:30:00 AM	7	32	1	0	40	0	1	3	73	1	0	78	1	3	2	61	19	0	86	0	3	22	48	2	0	72	0	1	276	
7:45:00 AM	9	51	0	0	60	2	0	3	95	0	0	98	3	5	1	46	25	0	80	0	1	40	67	10	0	117	0	0	355	
8:00:00 AM	13	64	6	0	83	2	1	4	87	0	0	92	0	3	1	45	36	0	85	1	4	31	100	16	0	147	0	0	407	
8:15:00 AM	8	54	9	0	71	2	1	3	80	1	0	85	1	0	3	37	27	0	68	2	0	40	70	5	0	116	0	0	340	
<b>Grand Total</b>	<b>37</b>	<b>201</b>	<b>16</b>	<b>0</b>	<b>254</b>	<b>6</b>	<b>3</b>	<b>13</b>	<b>335</b>	<b>2</b>	<b>0</b>	<b>353</b>	<b>6</b>	<b>11</b>	<b>7</b>	<b>189</b>	<b>107</b>	<b>0</b>	<b>319</b>	<b>3</b>	<b>8</b>	<b>133</b>	<b>285</b>	<b>34</b>	<b>0</b>	<b>452</b>	<b>3</b>	<b>1</b>	<b>1378</b>	
% Approach	14.6%	79.1%	6.3%	0.0%	0.0%	0.0%	0.0%	14.2%	85.8%	0.0%	0.0%	0.0%	0.0%	0.0%	45.1%	41.7%	13.2%	0.0%	0.0%	0.0%	0.0%	0.0%	66.2%	33.8%	0.0%	0.0%	0.0%	0.0%	0.0%	
% Total	2.7%	14.6%	1.2%	0.0%	18.4%	0.0%	0.0%	0.9%	24.3%	0.1%	0.0%	25.6%	0.0%	0.0%	0.5%	13.7%	7.8%	0.0%	23.1%	0.0%	0.0%	9.7%	20.7%	2.5%	0.0%	32.8%	0.0%	0.0%	0.846	
PHF	0.712	0.785	0.444	0.000	0.765	0.000	0.000	0.813	0.882	0.500	0.000	0.901	0.000	0.000	0.583	0.775	0.743	0.000	0.827	0.000	0.000	0.831	0.713	0.531	0.000	0.769	0.000	0.000	0.846	
Lights	36	189	12	0	237	0	0	10	317	1	0	328	0	0	7	169	103	0	279	0	0	133	274	34	0	441	0	0	1285	
% Lights	87.3%	94.0%	75.0%	0.0%	93.3%	0.0%	0.0%	76.9%	94.6%	50.0%	0.0%	92.9%	0.0%	0.0%	100.0%	89.4%	96.3%	0.0%	87.5%	0.0%	0.0%	100.0%	96.1%	100.0%	0.0%	97.6%	0.0%	0.0%	93.3%	
Trucks	0	0	0	0	0	0	0	1	1	0	0	2	0	0	0	1	1	0	2	0	0	0	4	0	0	4	0	0	8	
% Trucks	0.0%	0.0%	0.0%	0.0%	0.0%	0.0%	0.0%	7.7%	0.3%	0.0%	0.0%	0.6%	0.0%	0.0%	0.0%	0.5%	0.9%	0.0%	0.6%	0.0%	0.0%	0.0%	1.4%	0.0%	0.0%	0.9%	0.0%	0.0%	0.6%	
Buses	1	12	4	0	17	0	0	2	17	1	0	20	0	0	0	19	3	0	22	0	0	0	7	0	0	7	0	0	66	
% Buses	2.7%	6.0%	25.0%	0.0%	0.0%	0.0%	0.0%	15.4%	5.1%	50.0%	0.0%	0.0%	0.0%	0.0%	0.0%	10.1%	2.8%	0.0%	0.0%	0.0%	0.0%	0.0%	2.5%	0.0%	0.0%	0.0%	0.0%	0.0%	4.8%	
Pedestrians	0	0	0	0	0	6	3	0	0	0	0	0	5	11	0	0	0	0	0	3	8	0	0	0	0	0	0	1	0	
% Pedestrians	0.0%	0.0%	0.0%	0.0%	0.0%	100.0%	100.0%	0.0%	0.0%	0.0%	0.0%	0.0%	100.0%	100.0%	0.0%	0.0%	0.0%	0.0%	0.0%	0.9%	100.0%	100.0%	0.0%	0.0%	0.0%	0.0%	0.0%	0.0%	100.0%	0.0%
Bicycles on Crosswalk	0	0	0	0	0	0	0	0	0	0	0	0	0	0	0	0	0	0	0	0	0	0	0	0	0	0	0	0	0	
% Bicycles on Crosswalk	0.0%	0.0%	0.0%	0.0%	0.0%	0.0%	0.0%	0.0%	0.0%	0.0%	0.0%	0.0%	0.0%	0.0%	0.0%	0.0%	0.0%	0.0%	0.0%	0.0%	0.0%	0.0%	0.0%	0.0%	0.0%	0.0%	0.0%	0.0%	0.0%	

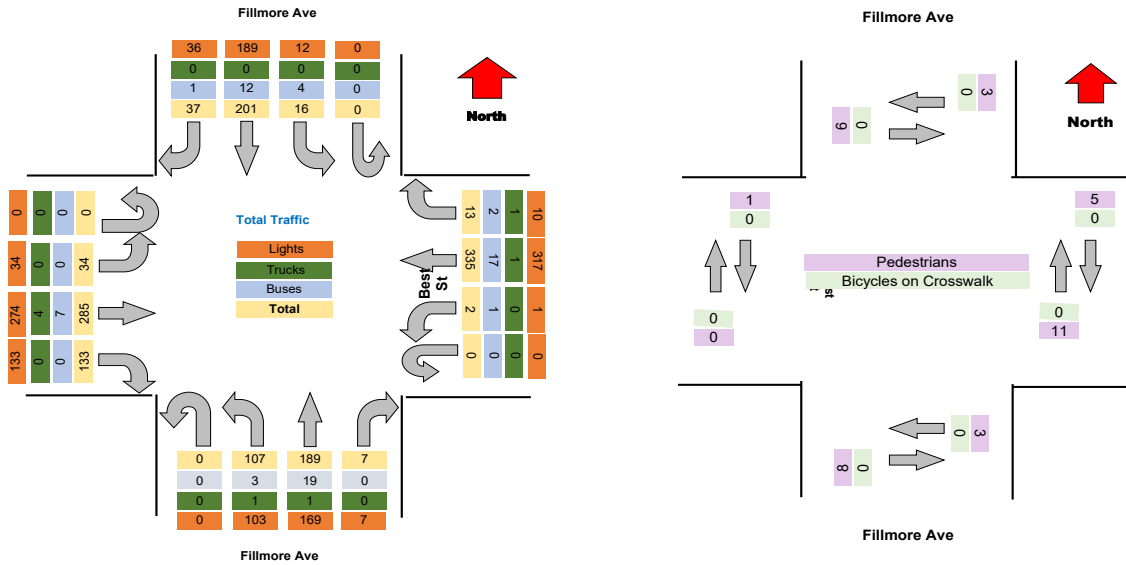



**Turning Movement Peak Hour Data (PM)**

4:30:00 PM

Leg Direction	Fillmore Ave				Best St				Fillmore Ave				Best St				Total				
	Southbound				Westbound				Northbound				Eastbound								
Start Time	Right	Thru	Left	U-Turn	App Total	Peds CW	Peds CCW	Right	Thru	Left	U-Turn	App Total	Peds CW	Peds CCW	Right	Thru	Left	U-Turn	App Total	Peds CW	Peds CCW
4:30:00 PM	13	61	7	0	81	0	2	6	102	0	0	108	0	0	32	108	10	0	150	0	0
4:45:00 PM	9	58	15	0	82	1	0	4	94	0	0	98	3	0	3	68	43	0	114	2	3
5:00:00 PM	7	46	14	0	67	3	0	12	80	0	0	92	0	3	1	50	26	0	77	2	0
5:15:00 PM	46	65	8	0	119	0	0	6	86	1	0	93	1	0	1	56	33	0	90	1	0
<b>Grand Total</b>	<b>45</b>	<b>239</b>	<b>44</b>	<b>0</b>	<b>319</b>	<b>4</b>	<b>2</b>	<b>28</b>	<b>372</b>	<b>1</b>	<b>0</b>	<b>421</b>	<b>4</b>	<b>3</b>	<b>5</b>	<b>229</b>	<b>147</b>	<b>0</b>	<b>381</b>	<b>3</b>	<b>3</b>
% Approach	14.1%	72.1%	13.8%	0.0%	0.0%	0.0%	0.0%	14.2%	85.6%	0.0%	0.0%	0.0%	0.0%	0.0%	45.1%	41.7%	13.2%	0.0%	0.0%	0.0%	0.0%
% Total	2.7%	13.7%	2.6%	0.0%	19.0%	0.0%	0.0%	1.7%	22.1%	0.1%	0.0%	23.9%	0.0%	0.0%	0.3%	13.6%	8.7%	0.0%	22.7%	0.0%	0.0%
PHF	0.703	0.885	0.733	0.000	0.896	0.000	0.000	0.583	0.912	0.250	0.000	0.928	0.000	0.000	0.417	0.842	0.817	0.000	0.836	0.000	0.000
Lights	45	217	44	0	306	0	0	28	366	1	0	395	0	0	5	213	144	0	362	0	0
% Lights	100.0%	94.3%	100.0%	0.0%	95.9%	0.0%	0.0%	100.0%	98.4%	100.0%	0.0%	98.5%	0.0%	0.0%	100.0%	93.0%	98.0%	0.0%	95.0%	0.0%	0.0%
Trucks	0	1	0	0	1	0	0	0	1	0	0	1	0	0	0	0	1	0	1	0	0
% Trucks	0.0%	0.4%	0.0%	0.0%	0.3%	0.0%	0.0%	0.0%	0.3%	0.0%	0.0%	0.2%	0.0%	0.0%	0.0%	0.0%	0.7%	0.0%	0.3%	0.0%	0.0%
Buses	0	12	0	0	12	0	0	0	4	0	0	4	0	0	0	9	1	0	10	0	0
% Buses	0.0%	5.2%	0.0%	0.0%	0.0%	0.0%	0.0%	0.0%	1.1%	0.0%	0.0%	0.0%	0.0%	0.0%	0.0%	3.9%	0.7%	0.0%	0.0%	0.0%	0.0%
Pedestrians	0	0	0	0	0	4	2	0	0	0	0	0	3	0	0	0	0	0	0	5	0
% Pedestrians	0.0%	0.0%	0.0%	0.0%	0.0%	100.0%	100.0%	0.0%	0.0%	0.0%	0.0%	0.0%	75.0%	0.0%	0.0%	0.0%	0.0%	0.0%	0.0%	100.0%	0.0%
Bicycles on Crosswalk	0	0	0	0	0	0	0	0	0	0	0	1	3	0	0	0	0	0	5	0	0
% Bicycles on Crosswalk	0.0%	0.0%	0.0%	0.0%	0.0%	0.0%	0.0%	0.0%	0.0%	0.0%	0.0%	0.0%	25.0%	100.0%	0.0%	0.0%	0.0%	0.0%	0.0%	100.0%	0.0%

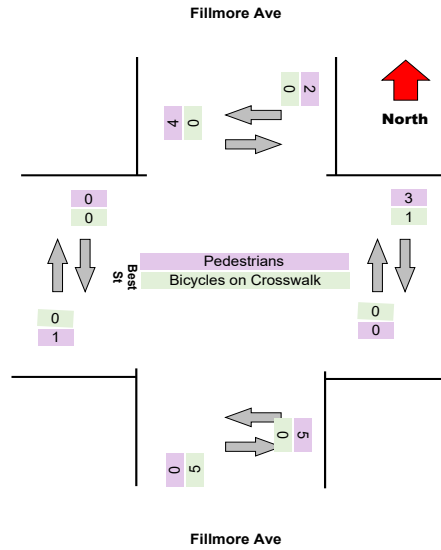
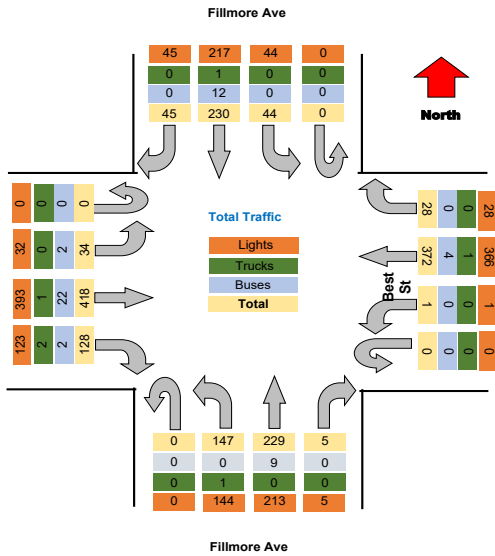

Project	Labella
Project Code	Labella
Site Name	17
Legs and Movements	All Processed Legs & Movements
Bin Size	15 minutes
Survey Date	2021-10-26, Tuesday
Location	17
Latitude and Longitude	42.903886, -78.839296

	Start	End	PHF
Forced Peak AM	2021/10/26 07:30:00	2021/10/26 08:30:00	0.898
Forced Peak PM	2021/10/26 16:30:00	2021/10/26 17:30:00	0.875
AM Peak	2021/10/26 07:30:00	2021/10/26 08:30:00	0.898
PM Peak	2021/10/26 16:30:00	2021/10/26 17:30:00	0.875

Turning Movement Data

Leg Direction	Fillmore Ave Southbound						Fillmore Ave NorthBound						Humboldt Pkwy S Eastbound					
	Right	Thru	U-Turn	App Total	Peds CW	Peds CCW	Thru	Left	U-Turn	App Total	Peds CW	Peds CCW	Right	Left	U-Turn	App Total	Peds CW	
6:30:00 AM	0	28	0	28	0	1	15	0	0	16	0	0	0	0	0	0	0	
6:45:00 AM	0	17	0	17	0	0	21	0	0	21	0	0	0	0	0	0	0	
<b>Hourly Total</b>	0	45	0	45	0	1	36	0	0	37	0	0	0	0	0	0	0	
7:00:00 AM	0	23	0	23	0	0	35	0	0	35	0	0	1	0	0	1	1	
7:15:00 AM	0	41	1	42	0	0	46	0	0	46	2	0	0	1	0	3	1	
7:30:00 AM	0	42	0	42	0	0	51	0	0	51	2	0	0	1	0	3	0	
7:45:00 AM	0	64	0	64	0	0	47	0	0	47	1	0	1	1	0	3	0	
<b>Hourly Total</b>	0	170	1	171	0	0	179	0	0	179	5	0	2	3	0	10	2	
8:00:00 AM	0	68	0	68	1	0	57	0	0	57	0	0	1	2	0	3	0	
8:15:00 AM	0	65	0	65	0	0	50	0	0	50	0	0	3	3	1	7	0	
<b>Hourly Total</b>	0	133	0	133	1	0	107	0	0	107	0	0	4	5	1	10	0	
4:00:00 PM	0	80	0	80	0	0	73	0	0	73	2	0	0	2	0	2	2	
4:15:00 PM	1	70	0	71	0	0	63	0	0	63	0	0	0	1	0	1	0	
4:30:00 PM	0	71	0	71	0	0	80	0	0	80	0	0	2	3	0	5	1	
4:45:00 PM	0	83	0	83	0	0	80	0	0	80	0	0	0	1	0	1	1	
<b>Hourly Total</b>	1	304	0	305	0	0	296	0	0	296	2	0	2	7	0	9	4	
5:00:00 PM	0	68	0	68	0	0	63	1	0	64	0	0	1	2	2	5	1	
5:15:00 PM	0	50	0	50	1	0	63	0	0	63	0	0	1	3	0	4	0	
5:30:00 PM	0	65	0	65	0	0	56	0	0	56	0	0	0	1	0	1	0	
5:45:00 PM	0	61	0	61	0	0	51	0	0	51	0	0	3	2	0	5	0	
<b>Hourly Total</b>	0	244	0	244	1	0	233	1	0	234	0	0	5	8	2	15	1	
<b>Grand Total</b>	1	896	1	898	2	1	851	1	0	853	7	0	13	23	3	44	7	
% Approach	0.1%	99.8%	0.1%	0.0%	0.0%	0.0%	99.8%	0.1%	0.0%	0.0%	0.0%	0.0%	29.5%	52.3%	6.8%	0.0%	0.0%	
% Total	0.1%	49.9%	0.1%	50.0%	0.0%	0.0%	47.4%	0.1%	0.0%	47.5%	0.0%	0.0%	0.7%	1.3%	0.2%	2.5%	0.0%	
Lights	1	847	1	849	0	0	782	1	0	783	0	0	12	23	3	38	0	
% Lights	100.0%	94.5%	100.0%	94.5%	0.0%	0.0%	91.9%	100.0%	0.0%	91.8%	0.0%	0.0%	92.3%	100.0%	100.0%	86.4%	0.0%	
Trucks	0	2	0	2	0	0	4	0	0	4	0	0	0	0	0	0	0	
% Trucks	0.0%	0.2%	0.0%	0.2%	0.0%	0.0%	0.5%	0.0%	0.0%	0.5%	0.0%	0.0%	0.0%	0.0%	0.0%	0.0%	0.0%	
Buses	0	47	0	47	0	0	65	0	0	65	0	0	1	0	0	1	0	
% Buses	0.0%	5.2%	0.0%	0.0%	0.0%	0.0%	0.0%	0.0%	0.0%	0.0%	0.0%	0.0%	7.7%	0.0%	0.0%	0.0%	0.0%	
Pedestrians	0	0	0	0	2	1	0	0	0	0	7	0	0	0	0	0	7	
% Pedestrians	0.0%	0.0%	0.0%	0.0%	100.0%	100.0%	0.0%	0.0%	0.0%	0.0%	100.0%	0.0%	0.0%	0.0%	0.0%	0.0%	100.0%	
% Bicycles on Crosswalk	0.0%	0.0%	0.0%	0.0%	0.0%	0.0%	0.0%	0.0%	0.0%	0.0%	0.0%	0.0%	0.0%	0.0%	0.0%	0.0%	0.0%	

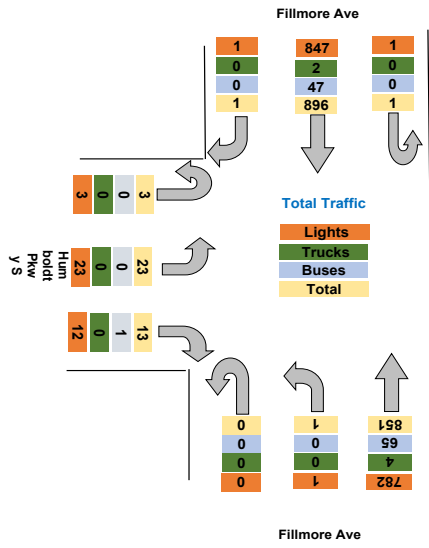

Turning Movement Data Plot

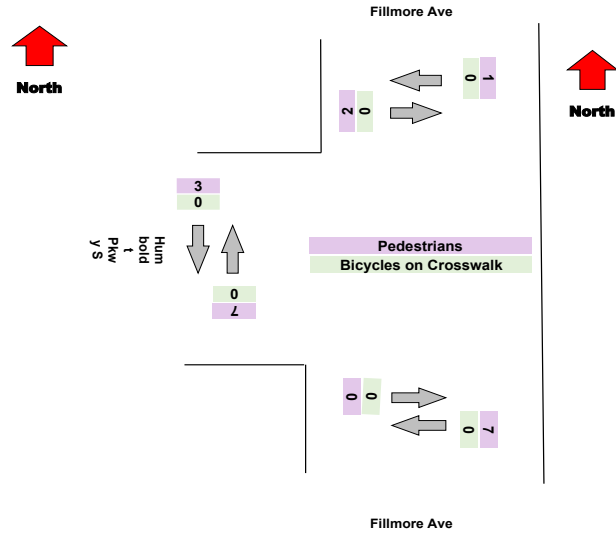

Turning Movement Peak Hour Data (AM)

7:30:00 AM

Leg Direction	Fillmore Ave Southbound						Fillmore Ave NorthBound						Humboldt Pkwy S Eastbound					
	Right	Thru	U-Turn	App Total	Peds CW	Peds CCW	Thru	Left	U-Turn	App Total	Peds CW	Peds CCW	Right	Left	U-Turn	App Total	Peds CW	
7:30:00 AM	0	42	0	42	0	0	51	0	0	51	2	0	0	1	0	0	3	0
7:45:00 AM	0	64	0	64	0	0	47	0	0	47	1	0	1	1	0	3	0	0
8:00:00 AM	0	68	0	68	1	0	57	0	0	57	0	0	1	2	0	3	0	0
8:15:00 AM	0	65	0	65	0	0	50	0	0	50	0	0	3	3	1	7	0	0
<b>Grand Total</b>	0	239	0	239	1	0	205	0	0	205	3	0	5	7	1	16	0	0
% Approach	0.0%	100.0%	0.0%	0.0%	0.0%	0.0%	14.2%	0.0%	0.0%	0.0%	0.0%	0.0%	45.1%	41.7%	0.0%	0.0%	0.0%	0.0%
% Total	0.0%	52.0%	0.0%	52.0%	0.0%	0.0%	44.6%	0.0%	0.0%	44.6%	0.0%	0.0%	1.1%	1.5%	0.2%	3.5%	0.0%	0.0%
PHF	0.000	0.879	0.000	0.879	0.000	0.000	0.899	0.000	0.000	0.899	0.000	0.000	0.417	0.583	0.250	0.571	0.000	0.000
Lights	0	224	0	224	0	0	185	0	0	185	0	0	4	7	1	12	0	0
% Lights	0.0%	93.7%	0.0%	93.7%	0.0%	0.0%	90.2%	0.0%	0.0%	90.2%	0.0%	0.0%	80.0%	100.0%	100.0%	75.0%	0.0%	0.0%
Trucks	0	0	0	0	0	0	2	0	0	2	0	0	0	0	0	0	0	0
% Trucks	0.0%	0.0%	0.0%	0.0%	0.0%	0.0%	1.0%	0.0%	0.0%	1.0%	0.0%	0.0%	0.0%	0.0%	0.0%	0.0%	0.0%	0.0%
Buses	0	15	0	15	0	0	18	0	0	18	0	0	1	0	0	1	0	0
% Buses	0.0%	6.3%	0.0%	6.3%	0.0%	0.0%	8.8%	0.0%	0.0%	8.8%	0.0%	0.0%	20.0%	0.0%	0.0%	6.3%	0.0%	0.0%
Pedestrians	0	0	0	0	1	0	0	0	0	0	3	0	0	0	0	0	0	0
% Pedestrians	0.0%	0.0%	0.0%	0.0%	100.0%	0.0%	0.0%	0.0%	0.0%	100.0%	0.0%	0.0%	0.0%	0.0%	0.0%	0.0%	0.0%	0.0%
Bicycles on Crosswalk	0	0	0	0	0	0	0	0	0	0	0	0	0	0	0	0	0	0
% Bicycles on Crosswalk	0.0%	0.0%	0.0%	0.0%	0.0%	0.0%	0.0%	0.0%	0.0%	0.0%	0.0%	0.0%	0.0%	0.0%	0.0%	0.0%	0.0%	0.0%

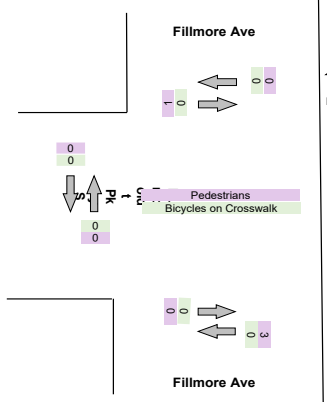
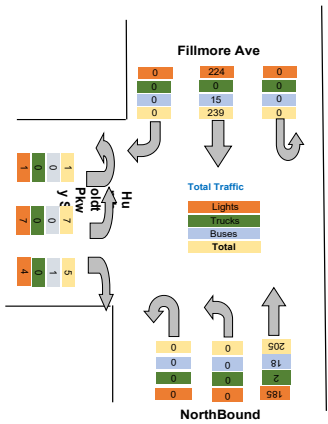

Turning Movement Peak Hour Data (PM)

4:30:00 PM

Leg Direction	Fillmore Ave Southbound						Fillmore Ave Northbound						Humboldt Pkwy S Eastbound					
	Right	Thru	U-Turn	App Total	Peds CW	Peds CCW	Thru	Left	U-Turn	App Total	Peds CW	Peds CCW	Right	Left	U-Turn	App Total	Peds CW	
4:30:00 PM	0	71	0	71	0	0	80	0	0	80	0	0	2	3	0	5	1	
4:45:00 PM	0	83	0	83	0	0	80	0	0	80	0	0	0	1	0	1	1	
5:00:00 PM	0	68	0	68	0	0	63	1	0	64	0	0	1	2	2	5	1	
5:15:00 PM	0	50	0	50	1	0	63	0	0	63	0	0	1	3	0	4	0	
<b>Grand Total</b>	0	272	0	272	1	0	286	1	0	287	0	0	4	9	2	15	3	
% Approach	0.0%	100.0%	0.0%	0.0%	0.0%	0.0%	14.2%	0.0%	0.0%	0.0%	0.0%	0.0%	45.1%	41.7%	0.0%	0.0%	0.0%	
% Total	0.0%	47.4%	0.0%	47.4%	0.0%	0.0%	49.8%	0.2%	0.0%	50.0%	0.0%	0.0%	0.7%	1.6%	0.3%	2.6%	0.0%	
PHF	0.000	0.819	0.000	0.819	0.000	0.000	0.894	0.250	0.000	0.897	0.000	0.000	0.500	0.750	0.250	0.750	0.000	
Lights	0	261	0	261	0	0	270	1	0	271	0	0	4	9	2	15	0	
% Lights	0.0%	96.0%	0.0%	96.0%	0.0%	0.0%	94.4%	100.0%	0.0%	94.4%	0.0%	0.0%	100.0%	100.0%	100.0%	100.0%	0.0%	
Trucks	0	1	0	1	0	0	1	0	0	1	0	0	0	0	0	0	0	
% Trucks	0.0%	0.4%	0.0%	0.4%	0.0%	0.0%	0.3%	0.0%	0.0%	0.3%	0.0%	0.0%	0.0%	0.0%	0.0%	0.0%	0.0%	
Buses	0	10	0	10	0	0	15	0	0	15	0	0	0	0	0	0	0	
% Buses	0.0%	3.7%	0.0%	3.7%	0.0%	0.0%	5.2%	0.0%	0.0%	5.2%	0.0%	0.0%	0.0%	0.0%	0.0%	0.0%	0.0%	
Pedestrians	0	0	0	0	1	0	0	0	0	0	0	0	0	0	0	0	3	
% Pedestrians	0.0%	0.0%	0.0%	0.0%	100.0%	0.0%	0.0%	0.0%	0.0%	0.0%	0.0%	0.0%	0.0%	0.0%	0.0%	0.0%	100.0%	
Bicycles on Crosswalk	0	0	0	0	0	0	0	0	0	0	0	0	0	0	0	0	0	
% Bicycles on Crosswalk	0.0%	0.0%	0.0%	0.0%	0.0%	0.0%	0.0%	0.0%	0.0%	0.0%	0.0%	0.0%	0.0%	0.0%	0.0%	0.0%	0.0%	

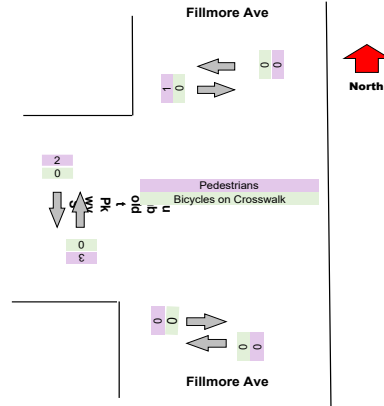
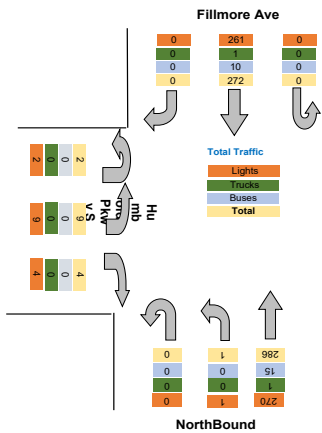

Intersection: Elm St Pine St  
 Location: Kennett Square, PA  
 Site: 01  
 Survey Date: Wednesday, 04-28-2021  
 GPS: 42.948550, -72.790034



Peds CCW	Total
1	44
0	38
1	82
0	59
0	91
0	96
0	114
0	360
0	128
0	122
0	250
0	155
0	135
1	156
1	164
2	610
0	137
0	117
0	122
0	117
0	493
3	1795
0.0%	0.0%
0.0%	0.0%
0	1670
0.0%	93.0%
0	6
0.0%	0.3%
0	113
0.0%	6.3%
3	0
100.0%	0.0%
0.0%	0.0%

Intersection: Elm St Pine St  
 Location: Kennett Square, PA  
 Site: 01  
 Survey Date: Wednesday, 04-28-2021  
 GPS: 42.948550, -72.790034



Peds CCW	<b>Total</b>
0	<b>96</b>
0	<b>114</b>
0	<b>128</b>
0	<b>122</b>
0	<b>460</b>
0.0%	
0.0%	
0.000	<b>0.898</b>
0	<b>421</b>
0.0%	<b>91.5%</b>
0	<b>2</b>
0.0%	<b>0.4%</b>
0	<b>34</b>
0.0%	<b>7.4%</b>
0	<b>0</b>
0.0%	<b>0.0%</b>
0	<b>0</b>
0.0%	<b>0.0%</b>

Intersection: Elm St Pine St  
 Location: Kennett Square, PA  
 Site: 01  
 Survey Date: Wednesday, 04-28-2021  
 GPS: 42.948550, -72.790034



Peds CCW	Total
1	156
1	164
0	137
0	117
2	574
0.0%	
0.0%	
0.000	0.875
0	547
0.0%	95.3%
0	2
0.0%	0.3%
0	25
0.0%	4.4%
2	0
100.0%	0.0%
0	0
0.0%	0.0%



Intersection: Elm St Pine St  
 Location: Kennett Square, PA  
 Site: 01  
 Survey Date: Wednesday, 04-28-2021  
 GPS: 42.948550, -72.790034



TSTData.com

Project	Labella
Project Code	Labella
Site Name	17
Legs and Movements	All Processed Legs & Movements
Bin Size	15 minutes
Survey Date	2021-10-27, Wednesday
Location	17
Latitude and Longitude	42.903886, -78.839296

	Start	End	PHF
Forced Peak AM	2021/10/27 07:30:00	2021/10/27 08:30:00	0.883
Forced Peak PM	2021/10/27 16:30:00	2021/10/27 17:30:00	0.902
AM Peak	2021/10/27 07:30:00	2021/10/27 08:30:00	0.883
PM Peak	2021/10/27 16:30:00	2021/10/27 17:30:00	0.902

Turning Movement Data

Leg Direction	Fillmore Ave Southbound						Fillmore Ave NorthBound						Humboldt Pkwy S Eastbound					
	Right	Thru	U-Turn	App Total	Peds CW	Peds CCW	Thru	Left	U-Turn	App Total	Peds CW	Peds CCW	Right	Left	U-Turn	App Total	Peds CW	Peds CCW
Start Time	0	22	0	22	0	0	14	0	0	14	0	0	0	0	0	0	0	0
6:30:00 AM	0	22	0	22	0	0	14	0	0	14	0	0	0	0	0	0	0	0
6:45:00 AM	0	30	0	30	0	1	30	0	0	31	0	0	0	0	0	0	0	0
Hourly Total	0	52	0	52	0	1	44	0	0	45	0	0	0	0	0	0	0	0
7:00:00 AM	0	36	0	36	0	0	27	0	0	27	0	0	0	0	0	0	0	0
7:15:00 AM	2	25	1	28	1	2	37	0	0	39	0	2	0	1	0	3	1	1
7:30:00 AM	1	40	0	41	0	1	47	0	0	48	0	1	1	1	0	3	0	0
7:45:00 AM	1	59	0	60	0	0	56	0	0	56	1	0	0	0	0	1	2	1
Hourly Total	4	160	1	165	1	3	167	0	0	170	1	3	1	2	0	7	3	2
8:00:00 AM	0	71	0	71	1	4	49	0	0	53	0	0	2	0	0	2	1	1
8:15:00 AM	0	61	0	61	0	0	48	0	0	48	0	0	1	0	0	1	0	0
Hourly Total	0	132	0	132	1	4	97	0	0	101	0	0	3	0	0	3	1	1
4:00:00 PM	0	107	0	107	1	2	72	0	0	72	2	0	2	5	0	7	0	3
4:15:00 PM	0	79	0	79	0	1	80	0	0	80	0	0	1	4	0	5	5	0
4:30:00 PM	0	64	0	64	1	0	85	0	0	85	4	0	2	1	0	3	5	3
4:45:00 PM	0	70	0	70	0	0	66	0	0	66	0	0	2	1	0	3	0	4
Hourly Total	0	320	0	320	2	3	303	0	0	303	6	0	7	11	0	18	10	10
5:00:00 PM	1	84	0	85	0	0	66	0	0	66	0	0	4	3	0	7	0	3
5:15:00 PM	0	60	0	60	0	0	61	0	0	61	0	0	0	0	0	0	2	3
5:30:00 PM	2	80	0	82	0	2	57	0	0	57	0	0	7	3	0	10	3	0
5:45:00 PM	0	47	0	47	0	0	48	0	0	48	1	1	0	3	0	3	0	1
Hourly Total	3	271	0	274	0	2	232	0	0	232	1	1	11	9	0	20	5	7
Grand Total	7	935	1	943	4	13	843	0	0	851	8	4	22	22	0	48	19	20
% Approach	0.7%	99.2%	0.1%	0.0%	0.0%	0.0%	99.1%	0.0%	0.0%	0.0%	0.0%	0.0%	45.8%	45.8%	0.0%	0.0%	0.0%	0.0%
% Total	0.4%	50.8%	0.1%	51.2%	0.0%	0.0%	45.8%	0.0%	0.0%	46.2%	0.0%	0.0%	1.2%	1.2%	0.0%	2.6%	0.0%	0.0%
Lights	7	876	1	884	0	0	770	0	0	770	0	0	22	22	0	44	0	0
% Lights	100.0%	93.7%	100.0%	93.7%	0.0%	0.0%	91.3%	0.0%	0.0%	90.5%	0.0%	0.0%	100.0%	100.0%	0.0%	91.7%	0.0%	0.0%
Trucks	0	1	0	1	0	0	3	0	0	3	0	0	0	0	0	0	0	0
% Trucks	0.0%	0.1%	0.0%	0.1%	0.0%	0.0%	0.4%	0.0%	0.0%	0.4%	0.0%	0.0%	0.0%	0.0%	0.0%	0.0%	0.0%	0.0%
Buses	0	55	0	55	0	0	68	0	0	68	0	0	0	0	0	0	0	0
% Buses	0.0%	5.9%	0.0%	0.0%	0.0%	0.0%	0.0%	0.0%	0.0%	0.0%	0.0%	0.0%	0.0%	0.0%	0.0%	0.0%	0.0%	0.0%
Pedestrians	0	0	0	0	4	13	0	0	0	0	8	4	0	0	0	0	17	15
% Pedestrians	0.0%	0.0%	0.0%	0.0%	100.0%	100.0%	0.0%	0.0%	0.0%	0.0%	100.0%	100.0%	0.0%	0.0%	0.0%	0.0%	89.5%	75.0%
% Bicycles on Crosswalk	0.0%	0.0%	0.0%	0.0%	0.0%	0.0%	0.0%	0.0%	0.0%	0.0%	0.0%	0.0%	0.0%	0.0%	0.0%	0.0%	10.5%	25.0%

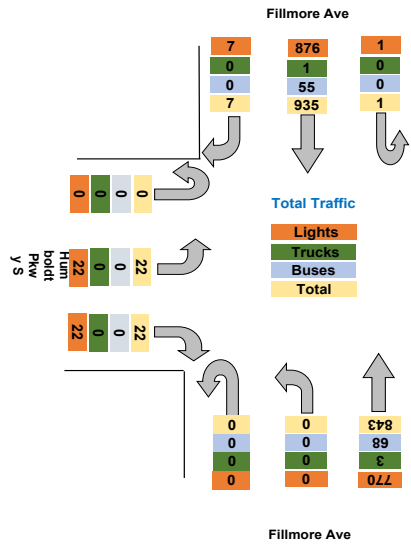

Turning Movement Data Plot

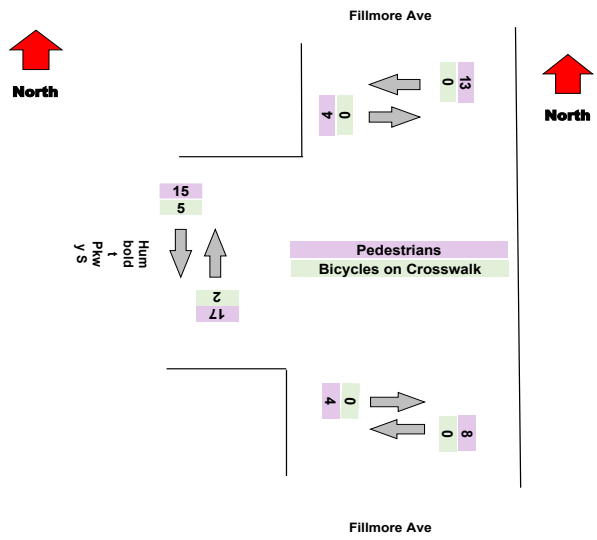

Turning Movement Peak Hour Data (AM)

7:30:00 AM

Leg Direction	Fillmore Ave Southbound						Fillmore Ave NorthBound						Humboldt Pkwy S Eastbound					
	Right	Thru	U-Turn	App Total	Peds CW	Peds CCW	Thru	Left	U-Turn	App Total	Peds CW	Peds CCW	Right	Left	U-Turn	App Total	Peds CW	Peds CCW
7:30:00 AM	1	40	0	41	0	1	47	0	0	48	0	1	1	1	0	3	0	0
7:45:00 AM	1	59	0	60	0	0	56	0	0	56	1	0	0	0	0	1	2	1
8:00:00 AM	0	71	0	71	1	4	49	0	0	53	0	0	2	0	0	2	1	1
8:15:00 AM	0	61	0	61	0	0	48	0	0	48	0	0	1	0	0	1	0	0
<b>Grand Total</b>	<b>2</b>	<b>231</b>	<b>0</b>	<b>233</b>	<b>1</b>	<b>5</b>	<b>200</b>	<b>0</b>	<b>0</b>	<b>205</b>	<b>1</b>	<b>1</b>	<b>4</b>	<b>1</b>	<b>0</b>	<b>7</b>	<b>3</b>	<b>2</b>
% Approach	0.9%	99.1%	0.0%	0.0%	0.0%	0.0%	14.2%	0.0%	0.0%	0.0%	0.0%	0.0%	45.1%	41.7%	0.0%	0.0%	0.0%	0.0%
% Total	0.4%	51.9%	0.0%	52.4%	0.0%	0.0%	44.9%	0.0%	0.0%	46.1%	0.0%	0.0%	0.9%	0.2%	0.0%	1.6%	0.0%	0.0%
PHF	0.500	0.813	0.000	0.820	0.000	0.000	0.893	0.000	0.000	0.915	0.000	0.000	0.500	0.250	0.000	0.583	0.000	0.000
Lights	2	209	0	211	0	0	178	0	0	178	0	0	4	1	0	5	0	0
% Lights	100.0%	90.5%	0.0%	90.6%	0.0%	0.0%	89.0%	0.0%	0.0%	86.8%	0.0%	0.0%	100.0%	100.0%	0.0%	71.4%	0.0%	0.0%
Trucks	0	0	0	0	0	0	1	0	0	1	0	0	0	0	0	0	0	0
% Trucks	0.0%	0.0%	0.0%	0.0%	0.0%	0.0%	0.5%	0.0%	0.0%	0.5%	0.0%	0.0%	0.0%	0.0%	0.0%	0.0%	0.0%	0.0%
Buses	0	21	0	21	0	0	21	0	0	21	0	0	0	0	0	0	0	0
% Buses	0.0%	9.1%	0.0%	0.0%	0.0%	0.0%	10.5%	0.0%	0.0%	0.0%	0.0%	0.0%	0.0%	0.0%	0.0%	0.0%	0.0%	0.0%
Pedestrians	0	0	0	0	1	5	0	0	0	0	1	1	0	0	0	0	2	1
% Pedestrians	0.0%	0.0%	0.0%	0.0%	100.0%	100.0%	0.0%	0.0%	0.0%	0.0%	100.0%	100.0%	0.0%	0.0%	0.0%	0.0%	66.7%	50.0%
Bicycles on Crosswalk	0	0	0	0	0	0	0	0	0	0	0	0	0	0	0	0	1	1
% Bicycles on Crosswalk	0.0%	0.0%	0.0%	0.0%	0.0%	0.0%	0.0%	0.0%	0.0%	0.0%	0.0%	0.0%	0.0%	0.0%	0.0%	0.0%	33.3%	50.0%

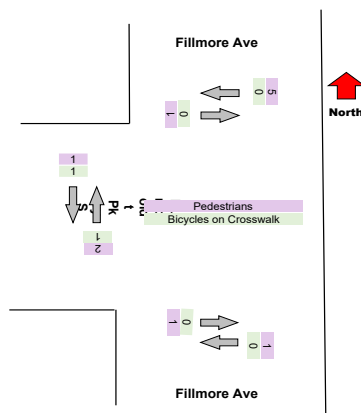
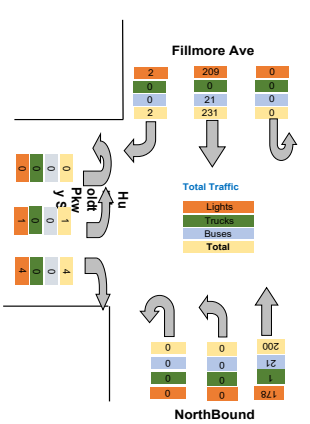

Turning Movement Peak Hour Data (PM)

4:30:00 PM

Leg Direction	Fillmore Ave Southbound						Fillmore Ave Northbound						Humboldt Pkwy S Eastbound					
	Right	Thru	U-Turn	App Total	Peds CW	Peds CCW	Thru	Left	U-Turn	App Total	Peds CW	Peds CCW	Right	Left	U-Turn	App Total	Peds CW	Peds CCW
4:30:00 PM	0	64	0	64	1	0	85	0	0	85	4	0	2	1	0	3	5	3
4:45:00 PM	0	70	0	70	0	0	66	0	0	66	0	0	2	1	0	3	0	4
5:00:00 PM	1	84	0	85	0	0	66	0	0	66	0	0	4	3	0	7	0	3
5:15:00 PM	0	60	0	60	0	0	61	0	0	61	0	0	0	0	0	0	2	3
<b>Grand Total</b>	<b>1</b>	<b>278</b>	<b>0</b>	<b>279</b>	<b>1</b>	<b>0</b>	<b>278</b>	<b>0</b>	<b>0</b>	<b>278</b>	<b>4</b>	<b>0</b>	<b>8</b>	<b>5</b>	<b>0</b>	<b>13</b>	<b>7</b>	<b>13</b>
% Approach	0.4%	99.6%	0.0%	0.0%	0.0%	0.0%	14.2%	0.0%	0.0%	0.0%	0.0%	0.0%	45.1%	41.7%	0.0%	0.0%	0.0%	0.0%
% Total	0.2%	48.8%	0.0%	48.9%	0.0%	0.0%	48.8%	0.0%	0.0%	48.8%	0.0%	0.0%	1.4%	0.9%	0.0%	2.3%	0.0%	0.0%
PHF	0.250	0.827	0.000	0.821	0.000	0.000	0.818	0.000	0.000	0.818	0.000	0.000	0.500	0.417	0.000	0.464	0.000	0.000
Lights	1	265	0	266	0	0	263	0	0	263	0	0	8	5	0	13	0	0
% Lights	100.0%	95.3%	0.0%	95.3%	0.0%	0.0%	94.6%	0.0%	0.0%	94.6%	0.0%	0.0%	100.0%	100.0%	0.0%	100.0%	0.0%	0.0%
Trucks	0	1	0	1	0	0	1	0	0	1	0	0	0	0	0	0	0	0
% Trucks	0.0%	0.4%	0.0%	0.4%	0.0%	0.0%	0.4%	0.0%	0.0%	0.4%	0.0%	0.0%	0.0%	0.0%	0.0%	0.0%	0.0%	0.0%
Buses	0	11	0	11	0	0	14	0	0	14	0	0	0	0	0	0	0	0
% Buses	0.0%	4.0%	0.0%	4.0%	0.0%	0.0%	5.0%	0.0%	0.0%	5.0%	0.0%	0.0%	0.0%	0.0%	0.0%	0.0%	0.0%	0.0%
Pedestrians	0	0	0	0	1	0	0	0	0	4	0	0	0	0	0	0	7	11
% Pedestrians	0.0%	0.0%	0.0%	0.0%	100.0%	0.0%	0.0%	0.0%	0.0%	100.0%	0.0%	0.0%	0.0%	0.0%	0.0%	0.0%	100.0%	84.6%
Bicycles on Crosswalk	0	0	0	0	0	0	0	0	0	0	0	0	0	0	0	0	0	2
% Bicycles on Crosswalk	0.0%	0.0%	0.0%	0.0%	0.0%	0.0%	0.0%	0.0%	0.0%	0.0%	0.0%	0.0%	0.0%	0.0%	0.0%	0.0%	0.0%	15.4%

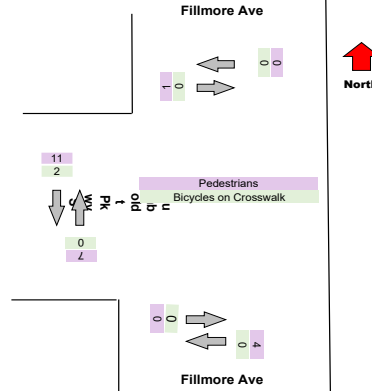
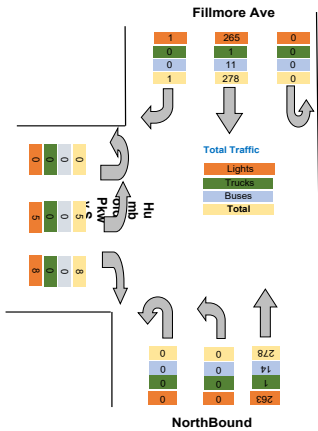

Intersection: Elm St Pine St  
 Location: Kennett Square, PA  
 Site: 01  
 Survey Date: Wednesday, 04-28-2021  
 GPS: 42.948550, -72.790034



<b>Total</b>
36
61
97
63
70
92
117
342
126
110
236
186
164
152
139
641
158
121
149
98
526
1842
0.0%
0.0%
1698
92.2%
4
0.2%
123
6.7%
0
0.0%
0.0%

Intersection: Elm St Pine St  
Location: Kennett Square, PA  
Site: 01  
Survey Date: Wednesday, 04-28-2021  
GPS: 42.948550, -72.790034



Total
92
117
126
110
445
0.883
394
88.5%
1
0.2%
42
9.4%
0
0.0%
0
0.0%

Intersection: Elm St Pine St  
Location: Kennett Square, PA  
Site: 01  
Survey Date: Wednesday, 04-28-2021  
GPS: 42.948550, -72.790034



Total
152
139
158
121
570
0.902
542
95.1%
2
0.4%
25
4.4%
0
0.0%
0
0.0%

Project	Labella
Project Code	Labella
Site Name	17
Legs and Movements	All Processed Legs & Movements
Bin Size	15 minutes
Survey Date	2021-10-28, Thursday
Location	17
Latitude and Longitude	42.903886, -78.839296

	Start	End	PHF
Forced Peak AM	2021/10/28 07:30:00	2021/10/28 08:30:00	0.828
Forced Peak PM	2021/10/28 16:30:00	2021/10/28 17:30:00	0.924
AM Peak	2021/10/28 07:30:00	2021/10/28 08:30:00	0.828
PM Peak	2021/10/28 16:30:00	2021/10/28 17:30:00	0.924

Turning Movement Data

Leg Direction	Fillmore Ave Southbound						Fillmore Ave NorthBound						Humboldt Pkwy S Eastbound					
	Right	Thru	U-Turn	App Total	Peds CW	Peds CCW	Thru	Left	U-Turn	App Total	Peds CW	Peds CCW	Right	Left	U-Turn	App Total	Peds CW	Peds CCW
Start Time																		
6:30:00 AM	0	15	0	15	0	0	13	0	0	13	0	0	0	0	0	0	0	0
6:45:00 AM	0	26	0	26	0	0	30	0	0	30	0	0	0	1	0	1	0	0
<b>Hourly Total</b>	0	41	0	41	0	0	43	0	0	43	0	0	0	1	0	1	0	0
7:00:00 AM	0	25	0	25	0	0	20	0	0	20	1	0	0	0	0	1	1	0
7:15:00 AM	0	33	0	33	0	0	33	0	0	33	0	0	0	0	0	0	1	1
7:30:00 AM	0	41	0	41	0	1	67	0	0	68	0	1	0	0	0	1	1	2
7:45:00 AM	0	60	0	60	2	0	58	0	0	58	1	1	1	2	0	5	0	0
<b>Hourly Total</b>	0	159	0	159	2	1	178	0	0	179	2	2	1	2	0	7	3	3
8:00:00 AM	2	80	0	82	1	0	66	0	0	66	0	3	1	2	0	6	2	1
8:15:00 AM	0	72	0	72	1	1	46	0	0	47	1	1	1	1	0	4	0	0
<b>Hourly Total</b>	2	152	0	154	2	1	112	0	0	113	1	4	2	3	0	10	2	1
4:00:00 PM	0	82	0	82	0	3	67	0	0	67	0	0	1	1	0	2	0	0
4:15:00 PM	0	80	0	80	0	0	75	0	0	75	1	0	1	3	0	4	0	1
4:30:00 PM	0	73	0	73	0	2	71	0	0	71	0	1	3	1	0	4	1	1
4:45:00 PM	0	80	0	80	2	0	79	0	0	79	0	0	1	1	0	2	4	5
<b>Hourly Total</b>	0	315	0	315	2	5	292	0	0	292	1	1	6	6	0	12	5	7
5:00:00 PM	0	68	0	68	0	0	68	0	0	68	0	0	0	5	0	5	0	0
5:15:00 PM	0	88	0	88	0	0	73	0	0	73	0	0	4	2	0	6	2	2
5:30:00 PM	0	80	0	80	0	0	68	0	0	68	0	0	3	1	0	4	0	2
5:45:00 PM	0	65	0	65	0	0	51	0	0	51	0	0	2	2	0	4	0	1
<b>Hourly Total</b>	0	301	0	301	0	0	260	0	0	260	0	0	9	10	0	19	2	5
<b>Grand Total</b>	2	968	0	970	6	7	885	0	0	887	4	7	18	22	0	49	12	16
% Approach	0.2%	99.8%	0.0%	0.0%	0.0%	0.0%	99.8%	0.0%	0.0%	0.0%	0.0%	0.0%	36.7%	44.9%	0.0%	0.0%	0.0%	0.0%
% Total	0.1%	50.8%	0.0%	50.9%	0.0%	0.0%	46.4%	0.0%	0.0%	46.5%	0.0%	0.0%	0.9%	1.2%	0.0%	2.6%	0.0%	0.0%
Lights	2	912	0	914	0	0	812	0	0	812	0	0	18	22	0	40	0	0
% Lights	100.0%	94.2%	0.0%	94.2%	0.0%	0.0%	91.8%	0.0%	0.0%	91.5%	0.0%	0.0%	100.0%	100.0%	0.0%	81.6%	0.0%	0.0%
Trucks	0	4	0	4	0	0	4	0	0	4	0	0	0	0	0	0	0	0
% Trucks	0.0%	0.4%	0.0%	0.4%	0.0%	0.0%	0.5%	0.0%	0.0%	0.5%	0.0%	0.0%	0.0%	0.0%	0.0%	0.0%	0.0%	0.0%
Buses	0	51	0	51	0	0	62	0	0	62	0	0	0	0	0	0	0	0
% Buses	0.0%	5.3%	0.0%	0.0%	0.0%	0.0%	0.0%	0.0%	0.0%	0.0%	0.0%	0.0%	0.0%	0.0%	0.0%	0.0%	0.0%	0.0%
Pedestrians	0	0	0	0	6	7	0	0	0	0	4	7	0	0	0	0	12	16
% Pedestrians	0.0%	0.0%	0.0%	0.0%	100.0%	100.0%	0.0%	0.0%	0.0%	0.0%	100.0%	100.0%	0.0%	0.0%	0.0%	0.0%	100.0%	100.0%
% Bicycles on Crosswalk	0.0%	0.0%	0.0%	0.0%	0.0%	0.0%	0.0%	0.0%	0.0%	0.0%	0.0%	0.0%	0.0%	0.0%	0.0%	0.0%	0.0%	0.0%



Turning Movement Data Plot

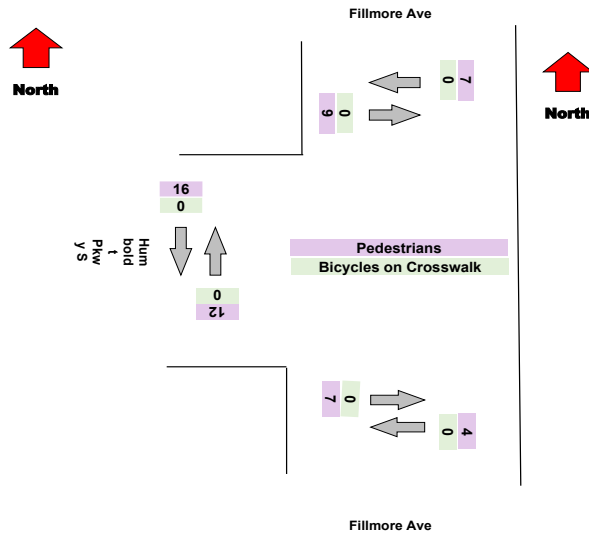
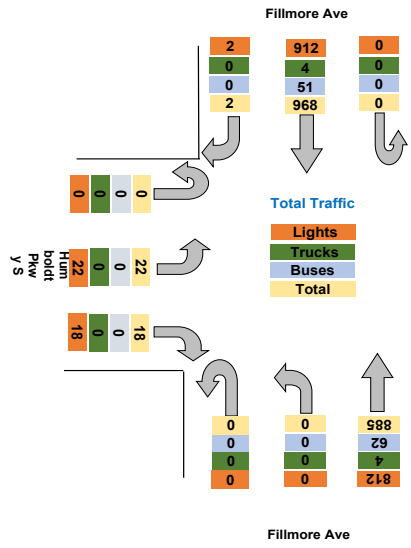

Turning Movement Peak Hour Data (AM)

7:30:00 AM

Leg Direction	Fillmore Ave Southbound						Fillmore Ave Northbound						Humboldt Pkwy S Eastbound					
	Right	Thru	U-Turn	App Total	Peds CW	Peds CCW	Thru	Left	U-Turn	App Total	Peds CW	Peds CCW	Right	Left	U-Turn	App Total	Peds CW	Peds CCW
7:30:00 AM	0	41	0	41	0	1	67	0	0	68	0	1	0	0	0	1	1	2
7:45:00 AM	0	60	0	60	2	0	58	0	0	58	1	1	1	2	0	5	0	0
8:00:00 AM	2	80	0	82	1	0	66	0	0	66	0	3	1	2	0	6	2	1
8:15:00 AM	0	72	0	72	1	1	46	0	0	47	1	1	1	1	0	4	0	0
<b>Grand Total</b>	2	253	0	255	4	2	237	0	0	239	2	6	3	5	0	16	3	3
% Approach	0.8%	99.2%	0.0%	0.0%	0.0%	0.0%	14.2%	0.0%	0.0%	0.0%	0.0%	0.0%	45.1%	41.7%	0.0%	0.0%	0.0%	0.0%
% Total	0.4%	49.6%	0.0%	50.0%	0.0%	0.0%	46.5%	0.0%	0.0%	46.9%	0.0%	0.0%	0.6%	1.0%	0.0%	3.1%	0.0%	0.0%
PHF	0.250	0.791	0.000	0.777	0.000	0.000	0.884	0.000	0.000	0.879	0.000	0.000	0.750	0.625	0.000	0.667	0.000	0.000
Lights	2	236	0	238	0	0	214	0	0	214	0	0	3	5	0	8	0	0
% Lights	100.0%	93.3%	0.0%	93.3%	0.0%	0.0%	90.3%	0.0%	0.0%	89.5%	0.0%	0.0%	100.0%	100.0%	0.0%	50.0%	0.0%	0.0%
Trucks	0	0	0	0	0	0	2	0	0	2	0	0	0	0	0	0	0	0
% Trucks	0.0%	0.0%	0.0%	0.0%	0.0%	0.0%	0.8%	0.0%	0.0%	0.8%	0.0%	0.0%	0.0%	0.0%	0.0%	0.0%	0.0%	0.0%
Buses	0	17	0	17	0	0	21	0	0	21	0	0	0	0	0	0	0	0
% Buses	0.0%	6.7%	0.0%	0.0%	0.0%	0.0%	8.9%	0.0%	0.0%	0.0%	0.0%	0.0%	0.0%	0.0%	0.0%	0.0%	0.0%	0.0%
Pedestrians	0	0	0	0	4	2	0	0	0	2	6	0	0	0	0	3	3	3
% Pedestrians	0.0%	0.0%	0.0%	0.0%	100.0%	100.0%	0.0%	0.0%	0.0%	0.0%	100.0%	100.0%	0.0%	0.0%	0.0%	0.0%	100.0%	100.0%
Bicycles on Crosswalk	0	0	0	0	0	0	0	0	0	0	0	0	0	0	0	0	0	0
% Bicycles on Crosswalk	0.0%	0.0%	0.0%	0.0%	0.0%	0.0%	0.0%	0.0%	0.0%	0.0%	0.0%	0.0%	0.0%	0.0%	0.0%	0.0%	0.0%	0.0%

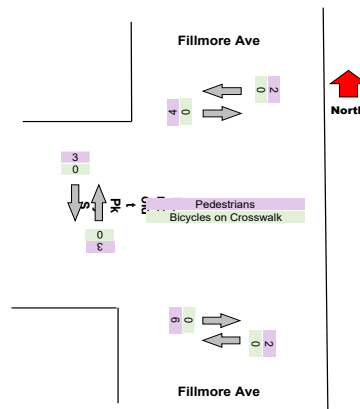
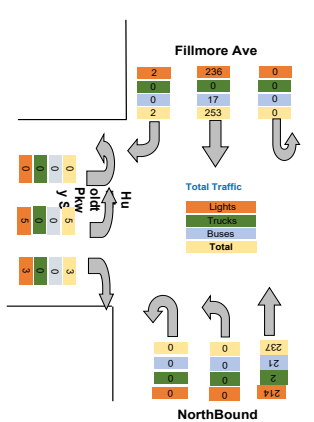

Turning Movement Peak Hour Data (PM)

4:30:00 PM

Leg Direction	Fillmore Ave Southbound						Fillmore Ave NorthBound						Humboldt Pkwy S Eastbound					
	Right	Thru	U-Turn	App Total	Peds CW	Peds CCW	Thru	Left	U-Turn	App Total	Peds CW	Peds CCW	Right	Left	U-Turn	App Total	Peds CW	Peds CCW
4:30:00 PM	0	73	0	73	0	2	71	0	0	71	0	1	3	1	0	4	1	1
4:45:00 PM	0	80	0	80	2	0	79	0	0	79	0	0	1	1	0	2	4	5
5:00:00 PM	0	68	0	68	0	0	68	0	0	68	0	0	0	5	0	5	0	0
5:15:00 PM	0	88	0	88	0	0	73	0	0	73	0	0	4	2	0	6	2	2
<b>Grand Total</b>	0	309	0	309	2	2	291	0	0	291	0	1	8	9	0	17	7	8
% Approach	0.0%	100.0%	0.0%	0.0%	0.0%	0.0%	14.2%	0.0%	0.0%	0.0%	0.0%	0.0%	45.1%	41.7%	0.0%	0.0%	0.0%	0.0%
% Total	0.0%	50.1%	0.0%	50.1%	0.0%	0.0%	47.2%	0.0%	0.0%	47.2%	0.0%	0.0%	1.3%	1.5%	0.0%	2.8%	0.0%	0.0%
PHF	0.000	0.878	0.000	0.878	0.000	0.000	0.921	0.000	0.000	0.921	0.000	0.000	0.500	0.450	0.000	0.708	0.000	0.000
Lights	0	295	0	295	0	0	273	0	0	273	0	0	8	9	0	17	0	0
% Lights	0.0%	95.5%	0.0%	95.5%	0.0%	0.0%	93.8%	0.0%	0.0%	93.8%	0.0%	0.0%	100.0%	100.0%	0.0%	100.0%	0.0%	0.0%
Trucks	0	1	0	1	0	0	0	0	0	0	0	0	0	0	0	0	0	0
% Trucks	0.0%	0.3%	0.0%	0.3%	0.0%	0.0%	0.0%	0.0%	0.0%	0.0%	0.0%	0.0%	0.0%	0.0%	0.0%	0.0%	0.0%	0.0%
Buses	0	13	0	13	0	0	11	0	0	11	0	0	0	0	0	0	0	0
% Buses	0.0%	4.2%	0.0%	4.2%	0.0%	0.0%	3.8%	0.0%	0.0%	3.8%	0.0%	0.0%	0.0%	0.0%	0.0%	0.0%	0.0%	0.0%
Pedestrians	0	0	0	0	2	2	0	0	0	0	1	1	0	0	0	0	7	8
% Pedestrians	0.0%	0.0%	0.0%	0.0%	100.0%	100.0%	0.0%	0.0%	0.0%	0.0%	100.0%	100.0%	0.0%	0.0%	0.0%	0.0%	100.0%	100.0%
Bicycles on Crosswalk	0	0	0	0	0	0	0	0	0	0	0	0	0	0	0	0	0	0
% Bicycles on Crosswalk	0.0%	0.0%	0.0%	0.0%	0.0%	0.0%	0.0%	0.0%	0.0%	0.0%	0.0%	0.0%	0.0%	0.0%	0.0%	0.0%	0.0%	0.0%

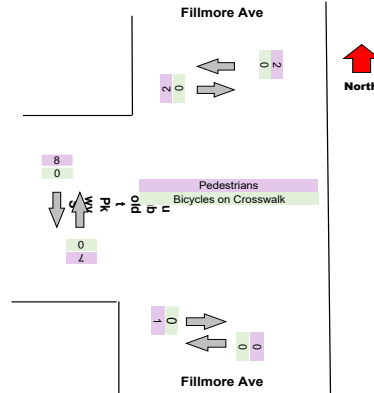
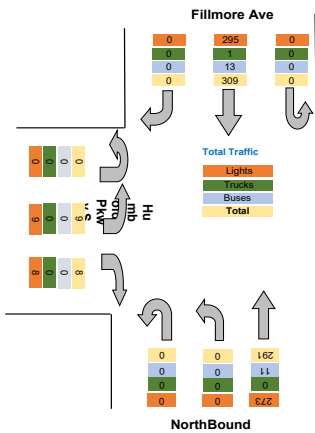

Intersection: Elm St Pine St  
Location: Kennett Square, PA  
Site: 01  
Survey Date: Wednesday, 04-28-2021  
GPS: 42.948550, -72.790034



<b>Total</b>
28
57
85
46
66
110
123
345
154
123
277
151
159
148
161
619
141
167
152
120
580
1906
0.0%
0.0%
1766
92.7%
8
0.4%
113
5.9%
0
0.0%
0.0%

Intersection: Elm St Pine St  
Location: Kennett Square, PA  
Site: 01  
Survey Date: Wednesday, 04-28-2021  
GPS: 42.948550, -72.790034



Total
110
123
154
123
510
0.828
460
90.2%
2
0.4%
38
7.5%
0
0.0%
0
0.0%

Intersection: Elm St Pine St  
Location: Kennett Square, PA  
Site: 01  
Survey Date: Wednesday, 04-28-2021  
GPS: 42.948550, -72.790034



Total
148
161
141
167
617
0.924
586
94.8%
1
0.2%
24
3.9%
0
0.0%
0
0.0%

Project	LaBella
Project Code	LaBella
Site Name	18
Legs and Movements	All Processed Legs & Movements
Bin Size	15 minutes
Survey Date	2021-11-02, Tuesday
Location	18
Latitude and Longitude	42.905776, -78.839064

	Start	End	PHF
Forced Peak AM	2021/11/02 07:30:00	2021/11/02 08:30:00	0.92
Forced Peak PM	2021/11/02 16:30:00	2021/11/02 17:30:00	0.938
AM Peak	2021/11/02 07:30:00	2021/11/02 08:30:00	0.92
PM Peak	2021/11/02 16:15:00	2021/11/02 17:15:00	0.966

Turning Movement Data

Leg Direction	Fillmore Ave Southbound						Fillmore Ave Northbound						Martin Luther King Park Eastbound														
	Right	Thru	U-Turn	App	Total	Peds	CW	Peds	CCW	Thru	Left	U-Turn	App	Total	Peds	CW	Peds	CCW	Right	Left	U-Turn	App	Total	Peds	CW		
6:30:00 AM	1	14	1	16	0	0	0	0	0	17	1	0	18	0	0	0	0	0	0	0	0	0	0	0	0	0	1
6:45:00 AM	0	25	0	25	0	0	0	0	0	24	2	0	26	1	0	0	0	0	2	0	0	0	3	1	0	0	1
<b>Hourly Total</b>	1	39	1	41	0	0	0	0	0	41	3	0	44	1	0	0	0	0	2	0	0	3	2	0	0	2	
7:00:00 AM	0	25	0	25	1	0	0	0	0	27	2	0	29	0	3	0	0	0	4	0	0	0	7	0	0	0	0
7:15:00 AM	0	23	0	23	0	0	0	0	0	30	1	0	31	2	0	0	0	0	2	0	0	0	4	0	0	0	0
7:30:00 AM	0	31	0	31	0	0	0	0	0	30	0	0	30	0	0	0	0	0	0	0	0	0	0	0	1	0	0
7:45:00 AM	0	31	0	31	0	0	0	0	0	35	0	0	35	0	0	0	0	0	0	0	0	0	0	0	0	0	0
<b>Hourly Total</b>	0	110	0	110	1	0	0	0	0	122	3	0	125	2	3	0	0	0	6	0	0	0	11	1	0	0	1
8:00:00 AM	0	37	0	37	0	0	0	0	0	25	0	0	25	1	0	0	0	0	3	0	0	0	4	0	0	0	0
8:15:00 AM	0	42	0	42	0	0	0	0	0	27	0	0	27	0	1	0	0	0	2	0	0	0	3	0	0	0	0
<b>Hourly Total</b>	0	79	0	79	0	0	0	0	0	52	0	0	52	1	1	0	0	0	5	0	0	0	7	0	0	0	0
4:00:00 PM	0	67	0	67	0	0	0	0	0	57	0	0	57	1	0	0	0	0	5	1	0	0	6	0	0	0	0
4:15:00 PM	0	63	0	63	0	0	0	0	0	67	0	0	67	0	1	0	0	0	0	1	0	0	1	0	0	0	0
4:30:00 PM	0	57	0	57	0	0	0	0	0	67	0	0	67	0	0	0	0	0	1	2	0	0	3	1	0	0	0
4:45:00 PM	0	53	0	53	0	0	0	0	0	65	0	0	65	0	0	0	0	0	1	1	0	0	2	0	0	0	0
<b>Hourly Total</b>	0	240	0	240	0	0	0	0	0	256	0	0	256	1	1	0	0	0	7	5	0	0	12	1	0	0	0
5:00:00 PM	0	63	0	63	0	0	0	0	0	66	0	0	66	0	0	0	0	0	2	1	0	0	3	0	0	0	0
5:15:00 PM	0	45	0	45	0	0	0	0	0	66	0	0	66	0	0	0	0	0	4	1	0	0	5	1	0	0	0
5:30:00 PM	0	60	0	60	0	0	0	0	0	42	0	0	42	0	0	0	0	0	6	2	0	0	8	0	0	0	0
5:45:00 PM	1	48	0	49	0	0	0	0	0	48	0	0	48	0	0	0	0	0	8	2	0	0	10	1	0	0	0
<b>Hourly Total</b>	1	216	0	217	0	0	0	0	0	222	0	0	222	0	0	0	0	0	20	6	0	0	26	2	0	0	0
<b>Grand Total</b>	2	684	1	687	1	0	0	0	0	693	6	0	699	5	5	0	0	0	40	11	0	0	59	5	0	0	0
% Approach	0.3%	99.6%	0.1%	0.0%	0.0%	0.0%	0.0%	0.0%	0.0%	99.1%	0.9%	0.0%	0.0%	0.0%	0.0%	0.0%	0.0%	0.0%	67.8%	18.6%	0.0%	0.0%	0.0%	0.0%	0.0%	0.0%	0.0%
% Total	0.1%	47.3%	0.1%	47.5%	0.0%	0.0%	0.0%	0.0%	0.0%	48.0%	0.4%	0.0%	48.4%	0.0%	0.0%	0.0%	0.0%	0.0%	2.8%	0.8%	0.0%	0.0%	4.1%	0.0%	0.0%	0.0%	0.0%
Lights	2	660	1	663	0	0	0	0	0	671	6	0	677	0	0	0	0	0	40	11	0	0	51	0	0	0	0
% Lights	100.0%	96.5%	100.0%	96.5%	0.0%	0.0%	0.0%	0.0%	0.0%	96.8%	100.0%	0.0%	96.9%	0.0%	0.0%	0.0%	0.0%	0.0%	100.0%	100.0%	0.0%	0.0%	86.4%	0.0%	0.0%	0.0%	0.0%
Trucks	0	2	0	2	0	0	0	0	0	3	0	0	3	0	0	0	0	0	0	0	0	0	0	0	0	0	0
% Trucks	0.0%	0.3%	0.0%	0.3%	0.0%	0.0%	0.0%	0.0%	0.0%	0.4%	0.0%	0.0%	0.4%	0.0%	0.0%	0.0%	0.0%	0.0%	0.0%	0.0%	0.0%	0.0%	0.0%	0.0%	0.0%	0.0%	0.0%
Buses	0	22	0	22	0	0	0	0	0	19	0	0	19	0	0	0	0	0	0	0	0	0	0	0	0	0	0
% Buses	0.0%	3.2%	0.0%	0.0%	0.0%	0.0%	0.0%	0.0%	0.0%	0.0%	0.0%	0.0%	0.0%	0.0%	0.0%	0.0%	0.0%	0.0%	0.0%	0.0%	0.0%	0.0%	0.0%	0.0%	0.0%	0.0%	0.0%
Pedestrians	0	0	0	0	1	0	0	0	0	0	0	0	0	5	5	0	0	0	0	0	0	0	0	5	0	0	0
% Pedestrians	0.0%	0.0%	0.0%	0.0%	100.0%	0.0%	0.0%	0.0%	0.0%	0.0%	0.0%	0.0%	0.0%	100.0%	100.0%	0.0%	0.0%	0.0%	0.0%	0.0%	0.0%	0.0%	0.0%	83.3%	0.0%	0.0%	0.0%
Bicycles on Crosswalk	0	0	0	0	0	0	0	0	0	0	0	0	0	0	0	0	0	0	0	0	0	0	0	1	0	0	0
% Bicycles on Crosswalk	0.0%	0.0%	0.0%	0.0%	0.0%	0.0%	0.0%	0.0%	0.0%	0.0%	0.0%	0.0%	0.0%	0.0%	0.0%	0.0%	0.0%	0.0%	0.0%	0.0%	0.0%	0.0%	0.0%	16.7%	0.0%	0.0%	0.0%

Turning Movement Data Plot

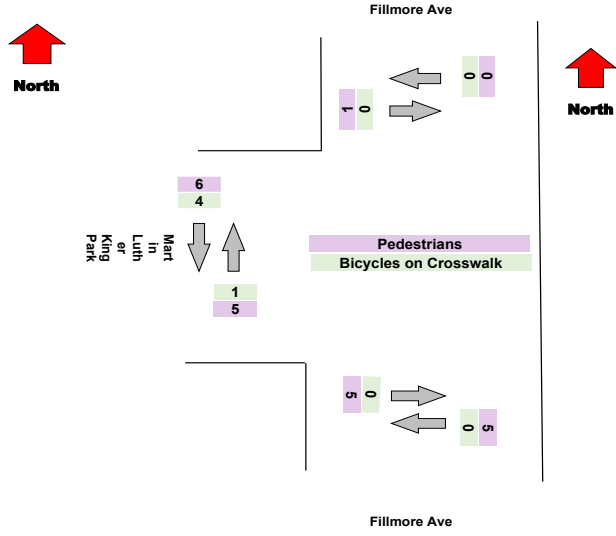
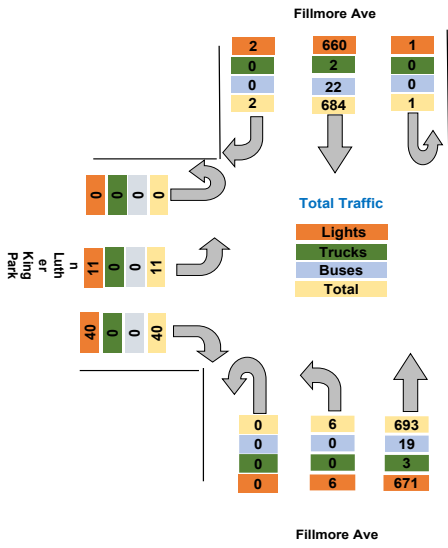



Turning Movement Peak Hour Data (AM)

7:30:00 AM

Leg Direction	Fillmore Ave Southbound						Fillmore Ave NorthBound						Martin Luther King Park Eastbound				
	Right	Thru	U-Turn	App Total	Peds CW	Peds CCW	Thru	Left	U-Turn	App Total	Peds CW	Peds CCW	Right	Left	U-Turn	App Total	Peds CW
Start Time																	
7:30:00 AM	0	31	0	31	0	0	30	0	0	30	0	0	0	0	0	0	1
7:45:00 AM	0	31	0	31	0	0	35	0	0	35	0	0	0	0	0	0	0
8:00:00 AM	0	37	0	37	0	0	25	0	0	25	1	0	3	0	0	4	0
8:15:00 AM	0	42	0	42	0	0	27	0	0	27	0	1	2	0	0	3	0
<b>Grand Total</b>	0	141	0	141	0	0	117	0	0	117	1	1	5	0	0	7	1
% Approach	0.0%	100.0%	0.0%	0.0%	0.0%	0.0%	100.0%	0.0%	0.0%	0.0%	0.0%	0.0%	71.4%	0.0%	0.0%	0.0%	0.0%
% Total	0.0%	53.2%	0.0%	53.2%	0.0%	0.0%	44.2%	0.0%	0.0%	44.2%	0.0%	0.0%	1.9%	0.0%	0.0%	2.6%	0.0%
PHF	0.000	0.839	0.000	0.839	0.000	0.000	0.836	0.000	0.000	0.836	0.000	0.000	0.417	0.000	0.000	0.438	0.000
Lights	0	132	0	132	0	0	109	0	0	109	0	0	5	0	0	5	0
% Lights	0.0%	93.6%	0.0%	93.6%	0.0%	0.0%	93.2%	0.0%	0.0%	93.2%	0.0%	0.0%	100.0%	0.0%	0.0%	71.4%	0.0%
Trucks	0	0	0	0	0	0	1	0	0	1	0	0	0	0	0	0	0
% Trucks	0.0%	0.0%	0.0%	0.0%	0.0%	0.0%	0.9%	0.0%	0.0%	0.9%	0.0%	0.0%	0.0%	0.0%	0.0%	0.0%	0.0%
Buses	0	9	0	9	0	0	7	0	0	7	0	0	0	0	0	0	0
% Buses	0.0%	6.4%	0.0%	6.4%	0.0%	0.0%	6.0%	0.0%	0.0%	6.0%	0.0%	0.0%	0.0%	0.0%	0.0%	0.0%	0.0%
Pedestrians	0	0	0	0	0	0	0	0	0	0	1	1	0	0	0	0	1
% Pedestrians	0.0%	0.0%	0.0%	0.0%	0.0%	0.0%	0.0%	0.0%	0.0%	0.0%	100.0%	100.0%	0.0%	0.0%	0.0%	0.0%	100.0%
Bicycles on Crosswalk	0	0	0	0	0	0	0	0	0	0	0	0	0	0	0	0	0
% Bicycles on Crosswalk	0.0%	0.0%	0.0%	0.0%	0.0%	0.0%	0.0%	0.0%	0.0%	0.0%	0.0%	0.0%	0.0%	0.0%	0.0%	0.0%	0.0%

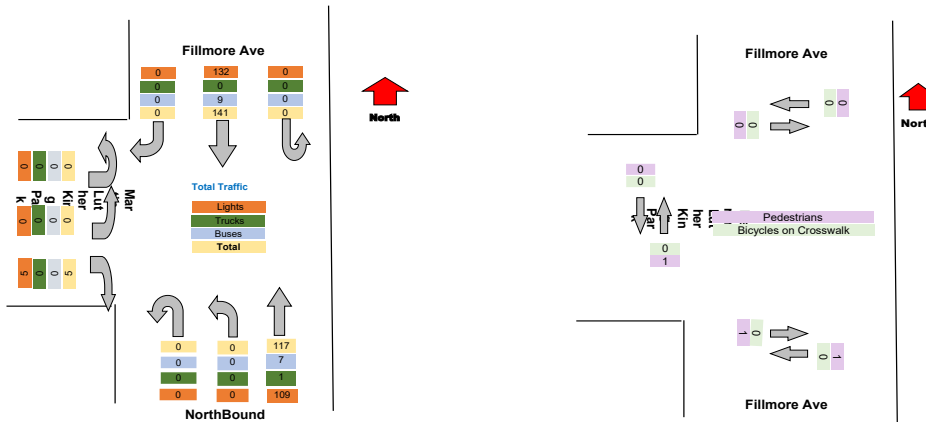

Turning Movement Peak Hour Data (PM)

4:15:00 PM

Leg Direction	Fillmore Ave Southbound						Fillmore Ave NorthBound						Martin Luther King Park Eastbound					
	Right	Thru	U-Turn	App Total	Peds CW	Peds CCW	Thru	Left	U-Turn	App Total	Peds CW	Peds CCW	Right	Left	U-Turn	App Total	Peds CW	
4:15:00 PM	0	63	0	63	0	0	67	0	0	67	0	1	0	1	0	1	0	
4:30:00 PM	0	57	0	57	0	0	67	0	0	67	0	0	1	2	0	3	1	
4:45:00 PM	0	53	0	53	0	0	65	0	0	65	0	0	1	1	0	2	0	
5:00:00 PM	0	63	0	63	0	0	66	0	0	66	0	0	2	1	0	3	0	
<b>Grand Total</b>	0	236	0	236	0	0	265	0	0	265	0	1	4	5	0	9	1	
% Approach	0.0%	100.0%	0.0%	0.0%	0.0%	0.0%	100.0%	0.0%	0.0%	0.0%	0.0%	0.0%	44.4%	55.6%	0.0%	0.0%	0.0%	
% Total	0.0%	46.3%	0.0%	46.3%	0.0%	0.0%	52.0%	0.0%	0.0%	52.0%	0.0%	0.0%	0.8%	1.0%	0.0%	1.8%	0.0%	
PHF	0.000	0.937	0.000	0.937	0.000	0.000	0.989	0.000	0.000	0.989	0.000	0.000	0.500	0.625	0.000	0.750	0.000	
Lights	0	228	0	228	0	0	262	0	0	262	0	0	4	5	0	9	0	
% Lights	0.0%	96.6%	0.0%	96.6%	0.0%	0.0%	98.9%	0.0%	0.0%	98.9%	0.0%	0.0%	100.0%	100.0%	0.0%	100.0%	0.0%	
Trucks	0	2	0	2	0	0	1	0	0	1	0	0	0	0	0	0	0	
% Trucks	0.0%	0.8%	0.0%	0.8%	0.0%	0.0%	0.4%	0.0%	0.0%	0.4%	0.0%	0.0%	0.0%	0.0%	0.0%	0.0%	0.0%	
Buses	0	6	0	6	0	0	2	0	0	2	0	0	0	0	0	0	0	
% Buses	0.0%	2.5%	0.0%	2.5%	0.0%	0.0%	0.8%	0.0%	0.0%	0.8%	0.0%	0.0%	0.0%	0.0%	0.0%	0.0%	0.0%	
Pedestrians	0	0	0	0	0	0	0	0	0	0	1	0	0	0	0	0	1	
% Pedestrians	0.0%	0.0%	0.0%	0.0%	0.0%	0.0%	0.0%	0.0%	0.0%	0.0%	100.0%	0.0%	0.0%	0.0%	0.0%	0.0%	100.0%	
Bicycles on Crosswalk	0	0	0	0	0	0	0	0	0	0	0	0	0	0	0	0	0	
% Bicycles on Crosswalk	0.0%	0.0%	0.0%	0.0%	0.0%	0.0%	0.0%	0.0%	0.0%	0.0%	0.0%	0.0%	0.0%	0.0%	0.0%	0.0%	0.0%	

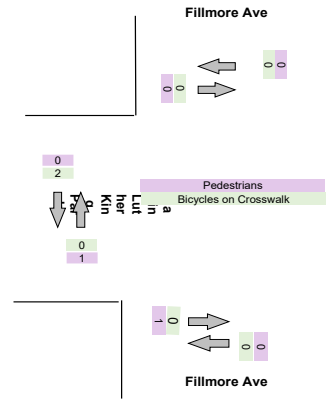
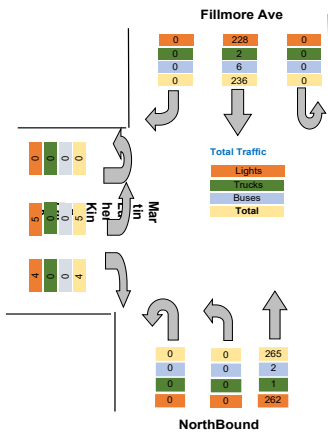

Intersection: Elm St Pine St  
 Location: Kennett Square, PA  
 Site: 01  
 Survey Date: Wednesday, 04-28-2021  
 GPS: 42.948550, -72.790034



Peds CCW	Total
1	34
0	54
1	88
4	61
0	58
0	61
0	66
4	246
0	66
0	72
0	138
1	130
1	131
1	127
0	120
3	508
0	132
1	116
0	110
1	107
2	465
10	1445
0.0%	0.0%
0.0%	0.0%
0	1391
0.0%	96.3%
0	5
0.0%	0.3%
0	41
0.0%	2.8%
6	0
60.0%	0.0%
4	0
40.0%	0.0%

Intersection: Elm St Pine St  
 Location: Kennett Square, PA  
 Site: 01  
 Survey Date: Wednesday, 04-28-2021  
 GPS: 42.948550, -72.790034



Peds CCW	<b>Total</b>
0	<b>61</b>
0	<b>66</b>
0	<b>66</b>
0	<b>72</b>
0	<b>265</b>
0.0%	
0.0%	
0.000	<b>0.920</b>
0	<b>246</b>
0.0%	<b>92.8%</b>
0	<b>1</b>
0.0%	<b>0.4%</b>
0	<b>16</b>
0.0%	<b>6.0%</b>
0	<b>0</b>
0.0%	<b>0.0%</b>
0	<b>0</b>
0.0%	<b>0.0%</b>

Intersection: Elm St Pine St  
 Location: Kennett Square, PA  
 Site: 01  
 Survey Date: Wednesday, 04-28-2021  
 GPS: 42.948550, -72.790034



Peds CCW	Total
1	131
1	127
0	120
0	132
2	510
0.0%	
0.0%	
0.000	0.966
0	499
0.0%	97.8%
0	3
0.0%	0.6%
0	8
0.0%	1.6%
0	0
0.0%	0.0%
2	0
100.0%	0.0%

Project	LaBella
Project Code	LaBella
Site Name	18
Legs and Movements	All Processed Legs & Movements
Bin Size	15 minutes
Survey Date	2021-11-03, Wednesday
Location	18
Latitude and Longitude	42.905776, -78.839064

	Start	End	PHF
Forced Peak AM	2021/11/03 07:30:00	2021/11/03 08:30:00	0.87890625
Forced Peak PM	2021/11/03 16:30:00	2021/11/03 17:30:00	0.866766467
AM Peak	2021/11/03 07:30:00	2021/11/03 08:30:00	0.87890625
PM Peak	2021/11/03 16:15:00	2021/11/03 17:15:00	0.905688623

Turning Movement Data

Leg Direction	Fillmore Ave Southbound						Fillmore Ave NorthBound						Martin Luther King Jr Eastbound			
	Right	Thru	U-Turn	App Total	Peds CW	Peds CCW	Thru	Left	U-Turn	App Total	Peds CW	Peds CCW	Right	Left	U-Turn	App Total
Start Time																
6:30:00 AM	0	19	0	19	0	0	23	0	0	23	0	0	1	1	0	2
6:45:00 AM	0	18	0	18	0	0	21	0	0	21	0	0	1	0	0	1
<b>Hourly Total</b>	0	37	0	37	0	0	44	0	0	44	0	0	2	1	0	3
7:00:00 AM	0	28	0	28	0	0	25	0	0	25	0	0	0	0	0	0
7:15:00 AM	0	30	0	30	1	0	36	0	0	36	0	0	4	1	0	5
7:30:00 AM	0	39	0	39	0	0	48	0	0	48	0	1	1	0	0	2
7:45:00 AM	0	54	0	54	0	0	60	0	0	60	0	0	4	7	0	11
<b>Hourly Total</b>	0	151	0	151	1	0	169	0	0	169	0	1	9	8	0	18
8:00:00 AM	0	54	0	54	0	0	46	0	0	46	0	0	5	3	0	8
8:15:00 AM	0	58	0	58	0	0	65	0	0	65	1	1	3	0	0	5
<b>Hourly Total</b>	0	112	0	112	0	0	111	0	0	111	1	1	8	3	0	13
4:00:00 PM	0	65	0	65	0	0	75	0	0	75	0	0	1	1	0	2
4:15:00 PM	0	68	0	68	0	0	77	0	0	77	0	0	9	1	0	10
4:30:00 PM	0	78	0	78	0	0	70	0	0	70	0	1	3	2	0	5
4:45:00 PM	0	79	0	79	0	0	83	0	0	83	0	5	2	3	0	5
<b>Hourly Total</b>	0	290	0	290	0	0	305	0	0	305	0	6	15	7	0	22
5:00:00 PM	0	62	0	62	0	0	63	0	1	64	0	0	4	0	0	4
5:15:00 PM	0	76	0	76	0	0	48	0	0	48	4	1	4	1	0	5
5:30:00 PM	0	67	0	67	0	0	68	0	0	68	0	0	1	0	0	1
5:45:00 PM	0	52	0	52	0	0	58	0	0	58	0	0	7	0	0	7
<b>Hourly Total</b>	0	257	0	257	0	0	237	0	1	238	4	1	16	1	0	17
<b>Grand Total</b>	0	847	0	847	1	0	866	0	1	867	5	9	50	20	0	73
% Approach	0.0%	100.0%	0.0%	0.0%	0.0%	0.0%	99.9%	0.0%	0.1%	0.0%	0.0%	0.0%	68.5%	27.4%	0.0%	0.0%
% Total	0.0%	47.4%	0.0%	47.4%	0.0%	0.0%	48.5%	0.0%	0.1%	48.5%	0.0%	0.0%	2.8%	1.1%	0.0%	4.1%
Lights	0	801	0	801	0	0	795	0	1	796	0	0	44	12	0	56
% Lights	0.0%	94.6%	0.0%	94.6%	0.0%	0.0%	91.8%	0.0%	100.0%	91.8%	0.0%	0.0%	88.0%	60.0%	0.0%	76.7%
Trucks	0	2	0	2	0	0	2	0	0	2	0	0	0	0	0	0
% Trucks	0.0%	0.2%	0.0%	0.2%	0.0%	0.0%	0.2%	0.0%	0.0%	0.2%	0.0%	0.0%	0.0%	0.0%	0.0%	0.0%
Buses	0	44	0	44	0	0	69	0	0	69	0	0	6	8	0	14
% Buses	0.0%	5.2%	0.0%	5.2%	0.0%	0.0%	7.9%	0.0%	0.0%	7.9%	0.0%	0.0%	12.0%	40.0%	0.0%	19.2%
Pedestrians	0	0	0	0	1	0	0	0	0	0	5	9	0	0	0	0
% Pedestrians	0.0%	0.0%	0.0%	0.0%	100.0%	0.0%	0.0%	0.0%	0.0%	0.0%	100.0%	100.0%	0.0%	0.0%	0.0%	0.0%
Bicycles on Crosswalk	0	0	0	0	0	0	0	0	0	0	0	0	0	0	0	0
% Bicycles on Crosswalk	0.0%	0.0%	0.0%	0.0%	0.0%	0.0%	0.0%	0.0%	0.0%	0.0%	0.0%	0.0%	0.0%	0.0%	0.0%	0.0%

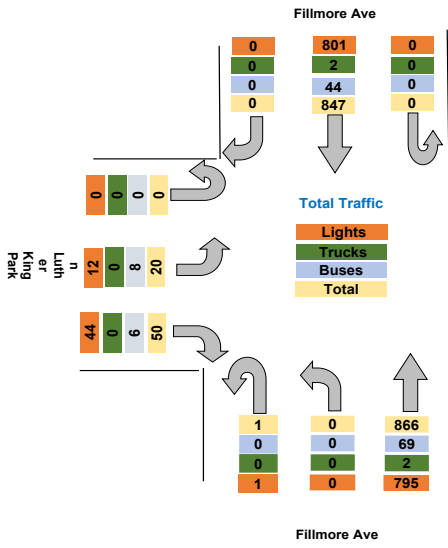

Turning Movement Data Plot

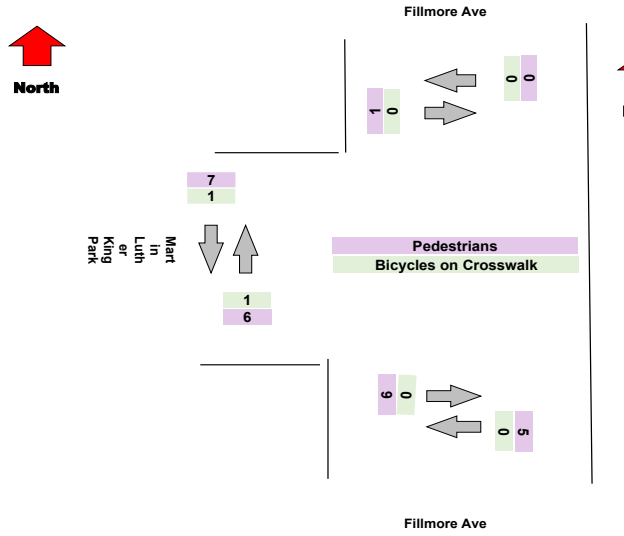

Turning Movement Peak Hour Data (AM)

7:30:00 AM

Leg Direction	Fillmore Ave Southbound						Fillmore Ave NorthBound						Martin Luther King F Eastbound			
	Right	Thru	U-Turn	App Total	Peds CW	Peds CCW	Thru	Left	U-Turn	App Total	Peds CW	Peds CCW	Right	Left	U-Turn	App Total
7:30:00 AM	0	39	0	39	0	0	48	0	0	48	0	1	1	0	0	2
7:45:00 AM	0	54	0	54	0	0	60	0	0	60	0	0	4	7	0	11
8:00:00 AM	0	54	0	54	0	0	46	0	0	46	0	0	5	3	0	8
8:15:00 AM	0	58	0	58	0	0	65	0	0	65	1	1	3	0	0	5
<b>Grand Total</b>	0	205	0	205	0	0	219	0	0	219	1	2	13	10	0	26
% Approach	0.0%	100.0%	0.0%	0.0%	0.0%	0.0%	100.0%	0.0%	0.0%	0.0%	0.0%	0.0%	50.0%	38.5%	0.0%	0.0%
% Total	0.0%	45.6%	0.0%	45.6%	0.0%	0.0%	48.7%	0.0%	0.0%	48.7%	0.0%	0.0%	2.9%	2.2%	0.0%	5.8%
PHF	0.000	0.884	0.000	0.884	0.000	0.000	0.842	0.000	0.000	0.842	0.000	0.000	0.650	0.357	0.000	0.591
Lights	0	192	0	192	0	0	192	0	0	192	0	0	7	2	0	9
% Lights	0.0%	93.7%	0.0%	93.7%	0.0%	0.0%	87.7%	0.0%	0.0%	87.7%	0.0%	0.0%	53.8%	20.0%	0.0%	34.6%
Trucks	0	0	0	0	0	0	0	0	0	0	0	0	0	0	0	0
% Trucks	0.0%	0.0%	0.0%	0.0%	0.0%	0.0%	0.0%	0.0%	0.0%	0.0%	0.0%	0.0%	0.0%	0.0%	0.0%	0.0%
Buses	0	13	0	13	0	0	27	0	0	27	0	0	6	8	0	14
% Buses	0.0%	6.3%	0.0%	6.3%	0.0%	0.0%	12.3%	0.0%	0.0%	12.3%	0.0%	0.0%	46.2%	80.0%	0.0%	51.9%
Pedestrians	0	0	0	0	0	0	0	0	0	0	1	2	0	0	0	0
% Pedestrians	0.0%	0.0%	0.0%	0.0%	0.0%	0.0%	0.0%	0.0%	0.0%	0.0%	100.0%	100.0%	0.0%	0.0%	0.0%	0.0%
Bicycles on Crosswalk	0	0	0	0	0	0	0	0	0	0	0	0	0	0	0	0
% Bicycles on Crosswalk	0.0%	0.0%	0.0%	0.0%	0.0%	0.0%	0.0%	0.0%	0.0%	0.0%	0.0%	0.0%	0.0%	0.0%	0.0%	0.0%

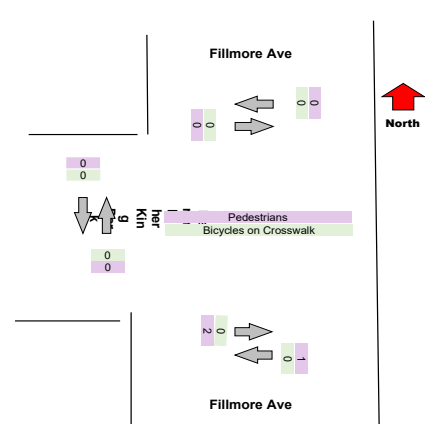
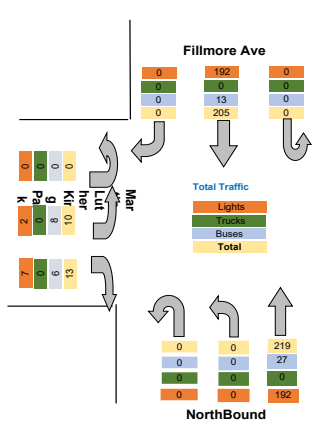



Turning Movement Peak Hour Data (PM)

4:15:00 PM

Leg Direction	Fillmore Ave Southbound						Fillmore Ave NorthBound						Martin Luther King f Eastbound			
	Right	Thru	U-Turn	App Total	Peds CW	Peds CCW	Thru	Left	U-Turn	App Total	Peds CW	Peds CCW	Right	Left	U-Turn	App Total
4:15:00 PM	0	68	0	68	0	0	77	0	0	77	0	0	9	1	0	10
4:30:00 PM	0	78	0	78	0	0	70	0	0	70	0	1	3	2	0	5
4:45:00 PM	0	79	0	79	0	0	83	0	0	83	0	5	2	3	0	5
5:00:00 PM	0	62	0	62	0	0	63	0	1	64	0	0	4	0	0	4
<b>Grand Total</b>	0	287	0	287	0	0	293	0	1	294	0	6	18	6	0	24
% Approach	0.0%	100.0%	0.0%	0.0%	0.0%	0.0%	99.7%	0.0%	0.3%	0.0%	0.0%	0.0%	75.0%	25.0%	0.0%	0.0%
% Total	0.0%	47.4%	0.0%	47.4%	0.0%	0.0%	48.4%	0.0%	0.2%	48.6%	0.0%	0.0%	3.0%	1.0%	0.0%	4.0%
PHF	0.000	0.908	0.000	0.908	0.000	0.000	0.883	0.000	0.250	0.886	0.000	0.000	0.500	0.500	0.000	0.600
Lights	0	272	0	272	0	0	278	0	1	279	0	0	18	6	0	24
% Lights	0.0%	94.8%	0.0%	94.8%	0.0%	0.0%	94.9%	0.0%	100.0%	94.9%	0.0%	0.0%	100.0%	100.0%	0.0%	100.0%
Trucks	0	1	0	1	0	0	1	0	0	1	0	0	0	0	0	0
% Trucks	0.0%	0.3%	0.0%	0.3%	0.0%	0.0%	0.3%	0.0%	0.0%	0.3%	0.0%	0.0%	0.0%	0.0%	0.0%	0.0%
Buses	0	14	0	14	0	0	14	0	0	14	0	0	0	0	0	0
% Buses	0.0%	4.9%	0.0%	4.9%	0.0%	0.0%	4.8%	0.0%	0.0%	4.8%	0.0%	0.0%	0.0%	0.0%	0.0%	0.0%
Pedestrians	0	0	0	0	0	0	0	0	0	0	6	0	0	0	0	0
% Pedestrians	0.0%	0.0%	0.0%	0.0%	0.0%	0.0%	0.0%	0.0%	0.0%	0.0%	100.0%	0.0%	0.0%	0.0%	0.0%	0.0%
Bicycles on Crosswalk	0	0	0	0	0	0	0	0	0	0	0	0	0	0	0	0
% Bicycles on Crosswalk	0.0%	0.0%	0.0%	0.0%	0.0%	0.0%	0.0%	0.0%	0.0%	0.0%	0.0%	0.0%	0.0%	0.0%	0.0%	0.0%

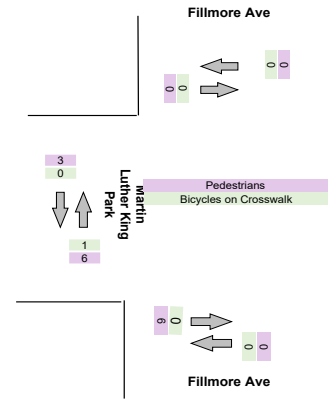
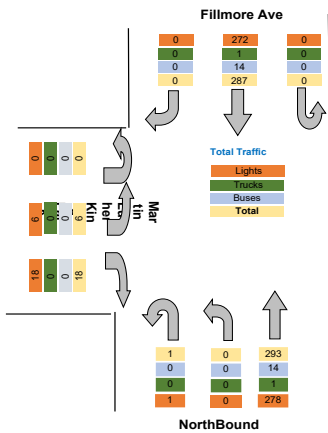

Intersection: Elm St Pine St  
 Location: Kennett Square, PA  
 Site: 01  
 Survey Date: Wednesday, 04-28-2021  
 GPS: 42.948550, -72.790034

Park		
Peds CW	Peds CCW	Total
0	0	44
0	0	40
0	0	84
0	0	53
0	2	71
0	0	89
0	0	125
0	2	338
0	0	108
0	0	128
0	0	236
0	1	142
0	1	155
1	0	153
4	2	167
5	4	617
2	0	130
0	2	129
0	0	136
0	0	117
2	2	512
7	8	1787
0.0%	0.0%	0.0%
0.0%	0.0%	0.0%
0	0	1653
0.0%	0.0%	92.5%
0	0	4
0.0%	0.0%	0.2%
0	0	127
0.0%	0.0%	7.1%
6	7	0
65.7%	67.5%	0.0%
1	1	0
14.3%	12.5%	0.0%

Intersection: Elm St Pine St  
Location: Kennett Square, PA  
Site: 01  
Survey Date: Wednesday, 04-28-2021  
GPS: 42.948550, -72.790034



North

Intersection: Elm St Pine St  
 Location: Kennett Square, PA  
 Site: 01  
 Survey Date: Wednesday, 04-28-2021  
 GPS: 42.948550, -72.790034

Park		
Peds CW	Peds CCW	Total
0	0	89
0	0	125
0	0	108
0	0	128
0	0	450
0.0%	0.0%	
0.0%	0.0%	
0.000	0.000	0.879
0	0	393
0.0%	0.0%	87.3%
0	0	0
0.0%	0.0%	0.0%
0	0	54
0.0%	0.0%	12.0%
0	0	0
0.0%	0.0%	0.0%
0	0	0
0.0%	0.0%	0.0%

Intersection: Elm St Pine St  
 Location: Kennett Square, PA  
 Site: 01  
 Survey Date: Wednesday, 04-28-2021  
 GPS: 42.948550, -72.790034



Park		
Peds CW	Peds CCW	Total
0	1	155
1	0	153
4	2	167
2	0	130
7	3	605
0.0%	0.0%	
0.0%	0.0%	
0.000	0.000	0.906
0	0	575
0.0%	0.0%	95.0%
0	0	2
0.0%	0.0%	0.3%
0	0	28
0.0%	0.0%	4.6%
6	3	0
85.7%	100.0%	0.0%
1	0	0
14.3%	0.0%	0.0%

Project	LaBella
Project Code	LaBella
Site Name	18
Legs and Movements	All Processed Legs & Movements
Bin Size	15 minutes
Survey Date	2021-11-04, Thursday
Location	18
Latitude and Longitude	42.905776, -78.839064

	Start	End	PHF
Forced Peak AM	2021/11/04 07:30:00	2021/11/04 08:30:00	0.838
Forced Peak PM	2021/11/04 16:30:00	2021/11/04 17:30:00	0.944
AM Peak	2021/11/04 07:30:00	2021/11/04 08:30:00	0.838
PM Peak	2021/11/04 16:15:00	2021/11/04 17:15:00	0.952

Turning Movement Data

Leg Direction	Fillmore Ave Southbound					Fillmore Ave Northbound					Martin Luther King Park Eastbound				
	Right	Thru	U-Turn	App Total	Peds CW Peds CCW	Thru	Left	U-Turn	App Total	Peds CW Peds CCW	Right	Left	U-Turn	App Total	Peds CW
Start Time															
6:30:00 AM	0	21	0	21	0 0	16	0	0	16	0 0	1	0	0	1	0
6:45:00 AM	0	23	0	23	0 0	19	0	0	19	0 1	1	0	0	2	0
<b>Hourly Total</b>	0	44	0	44	0 0	35	0	0	35	0 1	2	0	0	3	0
7:00:00 AM	0	25	0	25	0 0	25	0	0	25	0 0	0	0	0	0	1
7:15:00 AM	0	23	0	23	0 0	30	0	0	30	1 0	1	0	0	2	0
7:30:00 AM	0	48	0	48	0 0	40	0	0	40	0 0	1	1	0	2	0
7:45:00 AM	0	53	0	53	0 0	52	0	0	52	0 0	3	5	0	8	0
<b>Hourly Total</b>	0	149	0	149	0 0	147	0	0	147	1 0	5	6	0	12	1
8:00:00 AM	0	70	0	70	0 0	51	0	0	51	0 2	9	4	0	15	0
8:15:00 AM	0	61	0	61	0 0	46	0	0	46	4 0	6	0	0	10	1
<b>Hourly Total</b>	0	131	0	131	0 0	97	0	0	97	4 2	15	4	0	25	1
4:00:00 PM	0	69	0	69	0 0	68	0	0	68	0 0	5	3	0	8	1
4:15:00 PM	0	75	0	75	0 0	75	0	0	75	0 0	3	1	0	4	1
4:30:00 PM	0	62	0	62	0 0	81	0	0	81	0 0	3	0	0	3	0
4:45:00 PM	0	85	0	85	0 0	69	0	0	69	0 1	4	3	0	7	0
<b>Hourly Total</b>	0	291	0	291	0 0	293	0	0	293	0 1	15	7	0	22	2
5:00:00 PM	0	69	0	69	0 0	81	0	0	81	1 0	2	0	0	2	2
5:15:00 PM	0	73	0	73	0 0	75	0	0	75	0 1	1	0	0	1	0
5:30:00 PM	0	66	0	66	0 0	51	0	0	51	0 0	3	0	0	3	0
5:45:00 PM	0	67	0	67	0 0	55	0	0	55	0 0	1	0	0	1	0
<b>Hourly Total</b>	0	275	0	275	0 0	262	0	0	262	1 1	7	0	0	7	2
<b>Grand Total</b>	0	890	0	890	0 0	834	0	0	834	6 5	44	17	0	69	6
% Approach	0.0%	100.0%	0.0%	0.0%	0.0%	100.0%	0.0%	0.0%	0.0%	0.0%	63.8%	24.6%	0.0%	0.0%	0.0%
% Total	0.0%	49.6%	0.0%	49.6%	0.0%	46.5%	0.0%	0.0%	46.5%	0.0%	2.5%	0.9%	0.0%	3.8%	0.0%
Lights	0	842	0	842	0 0	767	0	0	767	0 0	37	10	0	47	0
% Lights	0.0%	94.6%	0.0%	94.6%	0.0%	92.0%	0.0%	0.0%	92.0%	0.0%	84.1%	58.8%	0.0%	68.1%	0.0%
Trucks	0	2	0	2	0 0	1	0	0	1	0 0	0	0	0	0	0
% Trucks	0.0%	0.2%	0.0%	0.2%	0.0%	0.1%	0.0%	0.0%	0.1%	0.0%	0.0%	0.0%	0.0%	0.0%	0.0%
Buses	0	46	0	46	0 0	66	0	0	66	0 0	7	7	0	14	0
% Buses	0.0%	5.2%	0.0%	0.0%	0.0%	0.0%	0.0%	0.0%	0.0%	0.0%	15.9%	41.2%	0.0%	0.0%	0.0%
Pedestrians	0	0	0	0	0 0	0	0	0	0	6 5	0	0	0	0	6
% Pedestrians	0.0%	0.0%	0.0%	0.0%	0.0%	0.0%	0.0%	0.0%	0.0%	100.0%	0.0%	0.0%	0.0%	0.0%	100.0%
Bicycles on Crosswalk	0	0	0	0	0 0	0	0	0	0	0 0	0	0	0	0	0
% Bicycles on Crosswalk	0.0%	0.0%	0.0%	0.0%	0.0%	0.0%	0.0%	0.0%	0.0%	0.0%	0.0%	0.0%	0.0%	0.0%	0.0%

Turning Movement Data Plot

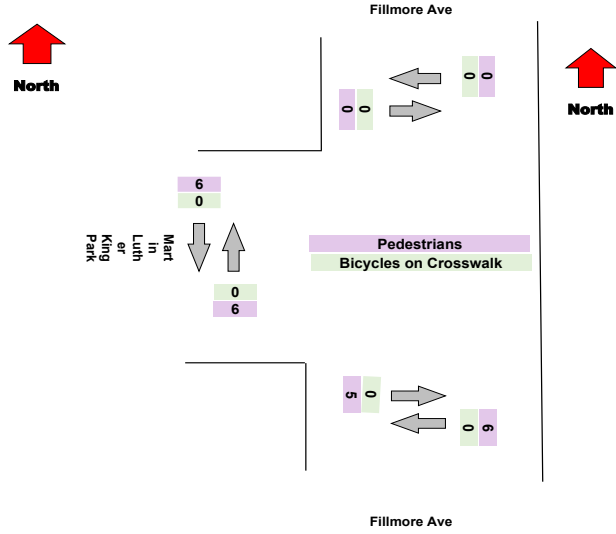
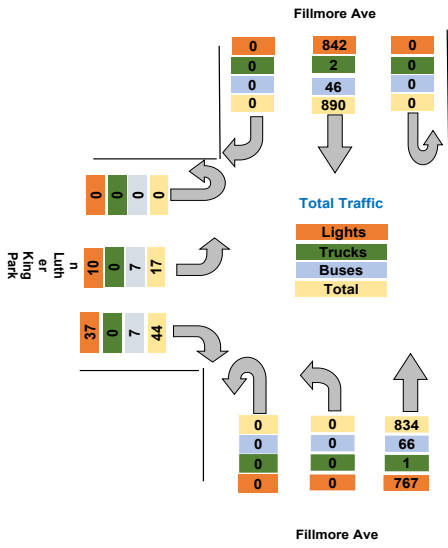

Turning Movement Peak Hour Data (AM)

7:30:00 AM

Leg Direction	Fillmore Ave Southbound						Fillmore Ave NorthBound						Martin Luther King Park Eastbound				
	Right	Thru	U-Turn	App Total	Peds CW	Peds CCW	Thru	Left	U-Turn	App Total	Peds CW	Peds CCW	Right	Left	U-Turn	App Total	Peds CW
7:30:00 AM	0	48	0	48	0	0	40	0	0	40	0	0	1	1	0	2	0
7:45:00 AM	0	53	0	53	0	0	52	0	0	52	0	0	3	5	0	8	0
8:00:00 AM	0	70	0	70	0	0	51	0	0	51	0	2	9	4	0	15	0
8:15:00 AM	0	61	0	61	0	0	46	0	0	46	4	0	6	0	0	10	1
<b>Grand Total</b>	0	232	0	232	0	0	189	0	0	189	4	2	19	10	0	35	1
% Approach	0.0%	100.0%	0.0%	0.0%	0.0%	0.0%	100.0%	0.0%	0.0%	0.0%	0.0%	0.0%	54.3%	28.6%	0.0%	0.0%	0.0%
% Total	0.0%	50.9%	0.0%	50.9%	0.0%	0.0%	41.4%	0.0%	0.0%	41.4%	0.0%	0.0%	4.2%	2.2%	0.0%	7.7%	0.0%
PHF	0.000	0.829	0.000	0.829	0.000	0.000	0.909	0.000	0.000	0.909	0.000	0.000	0.528	0.500	0.000	0.583	0.000
Lights	0	218	0	218	0	0	165	0	0	165	0	0	12	3	0	15	0
% Lights	0.0%	94.0%	0.0%	94.0%	0.0%	0.0%	87.3%	0.0%	0.0%	87.3%	0.0%	0.0%	63.2%	30.0%	0.0%	42.9%	0.0%
Trucks	0	0	0	0	0	0	0	0	0	0	0	0	0	0	0	0	0
% Trucks	0.0%	0.0%	0.0%	0.0%	0.0%	0.0%	0.0%	0.0%	0.0%	0.0%	0.0%	0.0%	0.0%	0.0%	0.0%	0.0%	0.0%
Buses	0	14	0	14	0	0	24	0	0	24	0	0	7	7	0	14	0
% Buses	0.0%	6.0%	0.0%	6.0%	0.0%	0.0%	12.7%	0.0%	0.0%	12.7%	0.0%	0.0%	36.8%	70.0%	0.0%	40.0%	0.0%
Pedestrians	0	0	0	0	0	0	0	0	0	0	4	2	0	0	0	0	1
% Pedestrians	0.0%	0.0%	0.0%	0.0%	0.0%	0.0%	0.0%	0.0%	0.0%	0.0%	100.0%	100.0%	0.0%	0.0%	0.0%	0.0%	100.0%
Bicycles on Crosswalk	0	0	0	0	0	0	0	0	0	0	0	0	0	0	0	0	0
% Bicycles on Crosswalk	0.0%	0.0%	0.0%	0.0%	0.0%	0.0%	0.0%	0.0%	0.0%	0.0%	0.0%	0.0%	0.0%	0.0%	0.0%	0.0%	0.0%

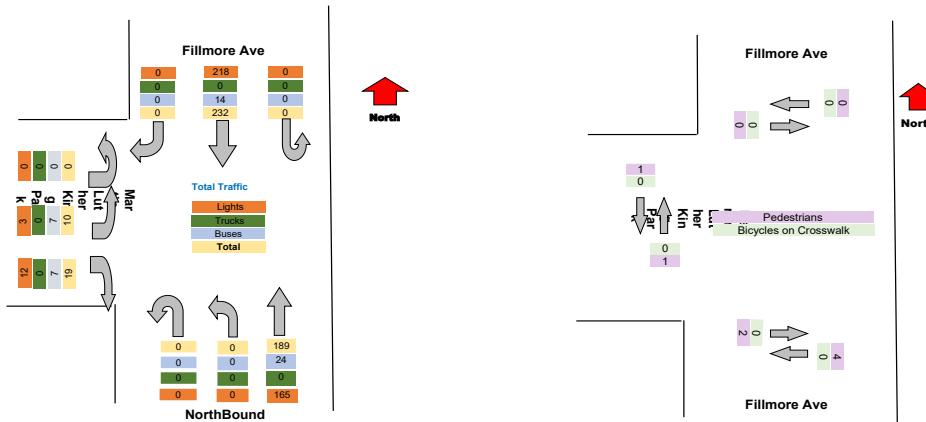



Turning Movement Peak Hour Data (PM)

4:15:00 PM

Leg Direction	Fillmore Ave Southbound						Fillmore Ave NorthBound						Martin Luther King Park Eastbound					
	Right	Thru	U-Turn	App Total	Peds CW	Peds CCW	Thru	Left	U-Turn	App Total	Peds CW	Peds CCW	Right	Left	U-Turn	App Total	Peds CW	
4:15:00 PM	0	75	0	75	0	0	75	0	0	75	0	0	3	1	0	4	1	
4:30:00 PM	0	62	0	62	0	0	81	0	0	81	0	0	3	0	0	3	0	
4:45:00 PM	0	85	0	85	0	0	69	0	0	69	0	1	4	3	0	7	0	
5:00:00 PM	0	69	0	69	0	0	81	0	0	81	1	0	2	0	0	2	2	
<b>Grand Total</b>	0	291	0	291	0	0	306	0	0	306	1	1	12	4	0	16	3	
% Approach	0.0%	100.0%	0.0%	0.0%	0.0%	0.0%	100.0%	0.0%	0.0%	0.0%	0.0%	0.0%	75.0%	25.0%	0.0%	0.0%	0.0%	
% Total	0.0%	47.5%	0.0%	47.5%	0.0%	0.0%	49.9%	0.0%	0.0%	49.9%	0.0%	0.0%	2.0%	0.7%	0.0%	2.6%	0.0%	
PHF	0.000	0.856	0.000	0.856	0.000	0.000	0.944	0.000	0.000	0.944	0.000	0.000	0.750	0.333	0.000	0.571	0.000	
Lights	0	275	0	275	0	0	291	0	0	291	0	0	12	4	0	16	0	
% Lights	0.0%	94.5%	0.0%	94.5%	0.0%	0.0%	95.1%	0.0%	0.0%	95.1%	0.0%	0.0%	100.0%	100.0%	0.0%	100.0%	0.0%	
Trucks	0	1	0	1	0	0	0	0	0	0	0	0	0	0	0	0	0	
% Trucks	0.0%	0.3%	0.0%	0.3%	0.0%	0.0%	0.0%	0.0%	0.0%	0.0%	0.0%	0.0%	0.0%	0.0%	0.0%	0.0%	0.0%	
Buses	0	15	0	15	0	0	15	0	0	15	0	0	0	0	0	0	0	
% Buses	0.0%	5.2%	0.0%	5.2%	0.0%	0.0%	4.9%	0.0%	0.0%	4.9%	0.0%	0.0%	0.0%	0.0%	0.0%	0.0%	0.0%	
Pedestrians	0	0	0	0	0	0	0	0	0	1	1	0	0	0	0	0	3	
% Pedestrians	0.0%	0.0%	0.0%	0.0%	0.0%	0.0%	0.0%	0.0%	0.0%	0.0%	100.0%	100.0%	0.0%	0.0%	0.0%	0.0%	100.0%	
Bicycles on Crosswalk	0	0	0	0	0	0	0	0	0	0	0	0	0	0	0	0	0	
% Bicycles on Crosswalk	0.0%	0.0%	0.0%	0.0%	0.0%	0.0%	0.0%	0.0%	0.0%	0.0%	0.0%	0.0%	0.0%	0.0%	0.0%	0.0%	0.0%	

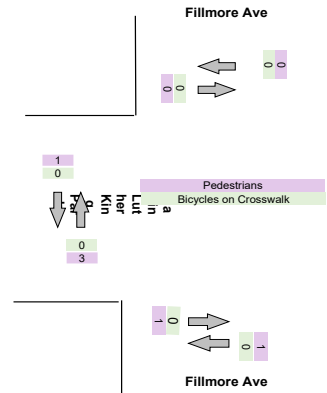
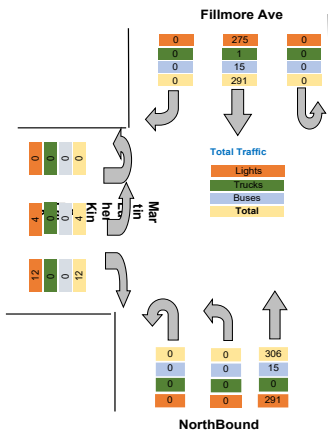

Intersection: Elm St Pine St  
 Location: Kennett Square, PA  
 Site: 01  
 Survey Date: Wednesday, 04-28-2021  
 GPS: 42.948550, -72.790034

Peds CCW	Total
0	38
1	44
1	82
0	50
1	55
1	90
0	113
2	308
0	136
0	117
0	253
0	145
0	154
1	146
0	161
1	606
0	152
0	149
2	120
0	123
2	544
6	1793
0.0%	0.0%
0.0%	0.0%
0	1656
0.0%	92.4%
0	3
0.0%	0.2%
0	126
0.0%	7.0%
6	0
100.0%	0.0%
0	0
0.0%	0.0%

Intersection: Elm St Pine St  
 Location: Kennett Square, PA  
 Site: 01  
 Survey Date: Wednesday, 04-28-2021  
 GPS: 42.948550, -72.790034



Peds CCW	<b>Total</b>
1	<b>90</b>
0	<b>113</b>
0	<b>136</b>
0	<b>117</b>
1	<b>456</b>
0.0%	
0.0%	
0.000	<b>0.838</b>
0	<b>398</b>
0.0%	<b>87.3%</b>
0	<b>0</b>
0.0%	<b>0.0%</b>
0	<b>52</b>
0.0%	<b>11.4%</b>
1	<b>0</b>
100.0%	<b>0.0%</b>
0	<b>0</b>
0.0%	<b>0.0%</b>

Intersection: Elm St Pine St  
 Location: Kennett Square, PA  
 Site: 01  
 Survey Date: Wednesday, 04-28-2021  
 GPS: 42.948550, -72.790034



Peds CCW	Total
0	154
1	146
0	161
0	152
1	613
0.0%	
0.0%	
0.000	0.952
0	582
0.0%	94.9%
0	1
0.0%	0.2%
0	30
0.0%	4.9%
1	0
100.0%	0.0%
0	0
0.0%	0.0%

Project : VBH Malta NY  
Site : Site 4  
Location : 42.948550, -73.790036

TSTData.com

Survey Date : 2021-04-28, Wednesday

Project	LaBella
Project Code	LaBella
Site Name	19
Legs and Movements	All Processed Legs & Move
Bin Size	15 minutes
Survey Date	2021-11-02, Tuesday
Location	19
Latitude and Longitude	42.907282, -78.839084

	Start	End	PHF
Forced Peak AM	2021/11/02 07:30:00	2021/11/02 08:30:00	0.88
Forced Peak PM	2021/11/02 16:30:00	2021/11/02 17:30:00	0.91
AM Peak	2021/11/02 07:30:00	2021/11/02 08:30:00	0.88
PM Peak	2021/11/02 16:15:00	2021/11/02 17:15:00	0.92

### Turning Movement Data

Leg Direction	Fillmore Ave										Northampton St										Total								
	Southbound					Westbound					Northbound					Eastbound													
	Right	Thru	Left	U-Turn	App Total	Peds CV	Peds CCV	Right	Thru	Left	U-Turn	App Total	Peds CV	Peds CCV	Right	Thru	Left	U-Turn	App Total	Peds CV		Peds CCV							
6:30:00 AM	1	15	3	0	19	0	0	1	0	0	0	1	0	0	1	16	1	0	18	0	1	1	3	2	0	6	0	1	44
6:45:00 AM	0	26	1	0	27	0	0	0	2	1	0	3	0	0	3	18	0	0	21	0	1	1	2	0	0	3	1	1	54
Hourly Total	1	41	4	0	46	0	0	1	2	1	0	4	0	0	4	34	1	0	39	0	2	2	5	2	0	9	1	2	98
7:00:00 AM	4	18	0	0	22	0	0	0	9	1	0	6	0	0	1	22	2	0	25	0	0	2	2	0	0	4	0	0	57
7:15:00 AM	2	25	0	0	27	0	0	1	2	1	0	4	0	1	0	29	3	0	33	1	1	0	5	1	0	6	0	0	70
7:30:00 AM	2	28	0	0	30	0	0	0	6	0	0	6	0	0	0	27	1	0	28	0	0	1	8	1	0	10	1	0	74
7:45:00 AM	5	37	1	0	43	0	0	0	4	3	0	7	0	0	2	36	1	0	39	0	0	2	7	0	0	9	0	0	98
Hourly Total	13	108	1	0	122	0	0	1	17	5	0	23	0	1	3	114	7	0	125	1	1	5	22	2	0	29	1	0	299
8:00:00 AM	5	36	0	0	41	0	0	1	6	0	0	7	0	0	0	21	3	0	24	0	0	1	4	3	0	8	0	0	80
8:15:00 AM	3	42	1	0	46	0	0	3	9	0	0	12	0	0	0	23	2	0	25	0	0	0	9	2	0	11	0	1	94
Hourly Total	8	78	1	0	87	0	0	4	15	0	0	19	0	0	0	44	5	0	49	0	0	1	13	5	0	19	0	1	174
4:00:00 PM	8	71	3	0	82	0	1	3	8	0	0	11	1	2	0	50	2	0	52	0	1	7	12	6	0	25	0	1	170
4:15:00 PM	4	62	1	0	67	0	0	0	8	3	0	11	0	0	1	65	7	0	73	0	0	2	15	3	0	20	1	1	171
4:30:00 PM	8	49	1	0	58	0	0	1	7	2	0	10	0	0	2	64	4	0	70	0	0	4	9	5	0	18	1	1	156
4:45:00 PM	9	60	2	0	71	0	0	5	6	2	0	13	0	0	4	63	1	0	68	0	0	2	14	7	0	23	3	1	175
Hourly Total	29	242	7	0	278	0	1	9	29	7	0	45	1	2	7	232	14	0	253	0	1	15	50	21	0	86	4	4	672
5:00:00 PM	15	64	5	0	74	0	0	4	10	3	0	17	0	0	2	67	2	0	71	0	1	9	11	4	0	24	0	1	186
5:15:00 PM	5	49	2	0	56	0	0	4	10	1	0	15	1	0	5	62	7	0	74	0	1	3	11	2	0	16	1	1	161
5:30:00 PM	6	65	1	0	72	0	0	3	6	0	0	9	0	1	0	57	0	0	57	0	0	2	14	6	0	22	0	0	160
5:45:00 PM	6	47	3	0	56	0	0	2	8	1	0	11	2	0	0	48	2	0	50	0	0	2	12	3	0	17	0	1	134
Hourly Total	32	215	11	0	258	0	0	13	34	5	0	52	3	1	7	234	11	0	252	0	2	16	48	15	0	79	1	5	641
Grand Total	83	684	24	0	791	0	1	28	97	18	0	143	4	4	21	668	38	0	728	1	6	39	138	45	0	222	7	12	1884
% Approach	10.5%	86.5%	3.0%	0.0%	0.0%	0.0%	0.0%	19.6%	67.8%	12.6%	0.0%	0.0%	0.0%	0.0%	2.9%	91.8%	5.2%	0.0%	0.0%	0.0%	0.0%	17.6%	62.2%	20.3%	0.0%	0.0%	0.0%	0.0%	0.0%
% Total	4.4%	36.3%	1.3%	0.0%	42.0%	0.0%	0.0%	1.5%	5.1%	1.0%	0.0%	7.6%	0.0%	0.0%	1.1%	35.5%	2.0%	0.0%	38.6%	0.0%	0.0%	2.1%	7.3%	2.4%	0.0%	11.8%	0.0%	0.0%	0.0%
Lights	82	660	24	0	766	0	0	28	95	18	0	141	0	0	21	645	38	0	704	0	0	39	136	44	0	219	0	0	1830
% Lights	98.8%	96.5%	100.0%	0.0%	96.8%	0.0%	0.0%	100.0%	97.9%	100.0%	0.0%	98.6%	0.0%	0.0%	100.0%	96.6%	100.0%	0.0%	96.7%	0.0%	0.0%	100.0%	98.6%	97.8%	0.0%	98.6%	0.0%	0.0%	97.1%
Trucks	0	2	0	0	2	0	0	0	0	0	0	0	0	0	0	2	0	0	2	0	0	0	0	0	0	0	0	0	4
% Trucks	0.0%	0.3%	0.0%	0.0%	0.3%	0.0%	0.0%	0.0%	0.0%	0.0%	0.0%	0.0%	0.0%	0.0%	0.0%	0.3%	0.0%	0.0%	0.3%	0.0%	0.0%	0.0%	0.0%	0.0%	0.0%	0.0%	0.0%	0.0%	0.2%
Buses	1	22	0	0	23	0	0	0	2	0	0	2	0	0	0	20	0	0	20	0	0	0	2	1	0	3	0	0	48
% Buses	1.2%	3.2%	0.0%	0.0%	0.0%	0.0%	0.0%	0.0%	2.1%	0.0%	0.0%	0.0%	0.0%	0.0%	0.0%	3.0%	0.0%	0.0%	0.0%	0.0%	0.0%	0.0%	1.4%	2.2%	0.0%	0.0%	0.0%	0.0%	2.5%
Pedestrians	0	0	0	0	0	0	0	0	0	0	0	0	3	3	0	0	0	0	0	1	6	0	0	0	0	0	6	9	0
% Pedestrians	0.0%	0.0%	0.0%	0.0%	0.0%	0.0%	100.0%	0.0%	0.0%	0.0%	0.0%	0.0%	75.0%	75.0%	0.0%	0.0%	0.0%	0.0%	0.0%	100.0%	100.0%	0.0%	0.0%	0.0%	0.0%	0.0%	85.7%	75.0%	0.0%
Bicycles on Crosswalk	0	0	0	0	0	0	0	0	0	0	0	0	1	1	0	0	0	0	0	0	0	0	0	0	0	0	1	3	0
% Bicycles on Crosswalk	0.0%	0.0%	0.0%	0.0%	0.0%	0.0%	0.0%	0.0%	0.0%	0.0%	0.0%	0.0%	25.0%	25.0%	0.0%	0.0%	0.0%	0.0%	0.0%	0.0%	0.0%	0.0%	0.0%	0.0%	0.0%	0.0%	14.3%	25.0%	0.0%

Project : VBH Malta NY  
 Site : Site 4  
 Location : 42.948550, -73.790036  
 Survey Date : 2021-04-28, Wednesday

### Turning Movement Data Plot

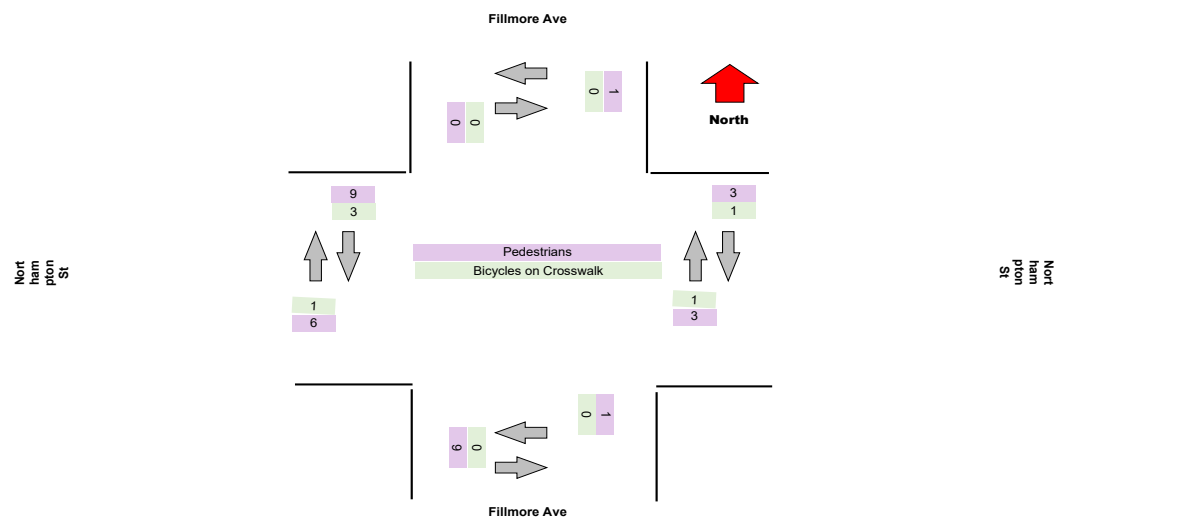
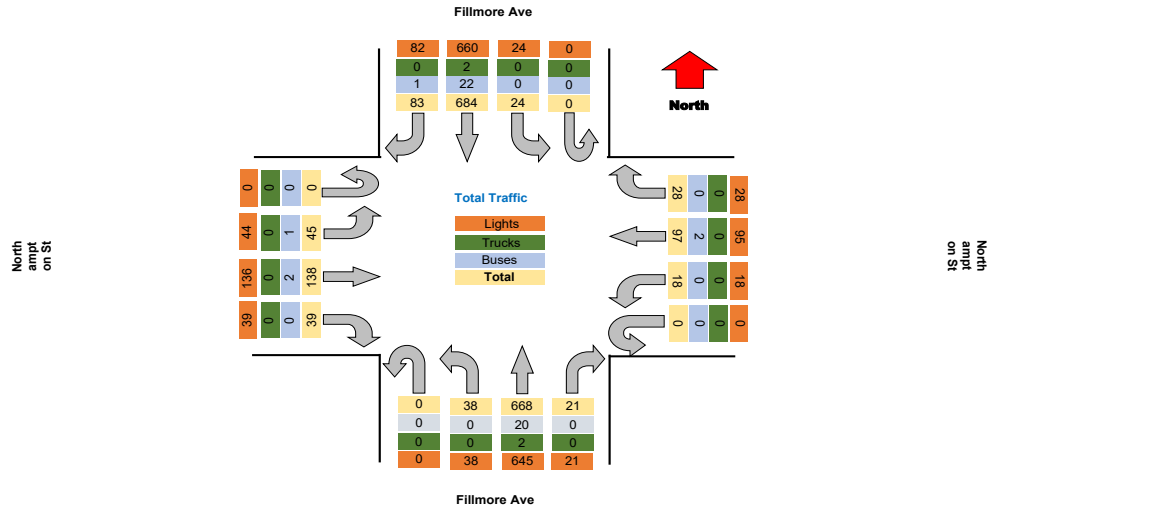

Project : VBH Malta NY  
Site : Site 4  
Location : 42.948550, -73.790036  
Survey Date : 2021-04-28, Wednesday

TSTData.com

**Turning Movement Peak Hour Data (AM)**

7:30:00 AM

Leg Direction	Fillmore Ave				Northampton St				Fillmore Ave				Northampton St				Total						
	Southbound		Northbound		Westbound		Eastbound		Northbound		Southbound		Westbound		Eastbound								
Start Time	Right	Thru	Left	U-Turn	App Total	Peds CW	Peds CCW	Right	Thru	Left	U-Turn	App Total	Peds CW	Peds CCW	Right	Thru	Left	U-Turn	App Total	Peds CW	Peds CCW	Total	
7:30:00 AM	2	28	0	0	30	0	0	0	6	0	0	6	0	0	0	27	1	0	28	0	0	0	74
7:45:00 AM	5	37	1	0	43	0	0	0	4	3	0	7	0	0	2	36	1	0	39	0	0	0	98
8:00:00 AM	5	36	0	0	41	0	0	1	6	0	0	7	0	0	0	21	3	0	24	0	0	0	80
8:15:00 AM	3	42	1	0	46	0	0	3	9	0	0	12	0	0	0	23	2	0	25	0	0	0	94
<b>Grand Total</b>	<b>15</b>	<b>143</b>	<b>2</b>	<b>0</b>	<b>160</b>	<b>0</b>	<b>0</b>	<b>4</b>	<b>25</b>	<b>3</b>	<b>0</b>	<b>32</b>	<b>0</b>	<b>0</b>	<b>2</b>	<b>107</b>	<b>7</b>	<b>0</b>	<b>116</b>	<b>0</b>	<b>0</b>	<b>0</b>	<b>346</b>
% Approach	9.4%	89.4%	1.3%	0.0%	0.0%	0.0%	0.0%	12.5%	78.1%	9.4%	0.0%	0.0%	0.0%	0.0%	1.7%	92.2%	6.0%	0.0%	0.0%	0.0%	0.0%	0.0%	0.0%
% Total	4.3%	41.3%	0.6%	0.0%	46.2%	0.0%	0.0%	1.2%	7.2%	0.9%	0.0%	8.2%	0.0%	0.0%	0.6%	30.9%	2.0%	0.0%	33.5%	0.0%	0.0%	0.0%	0.0%
PHF	0.750	0.851	0.500	0.000	0.870	0.000	0.000	0.333	0.694	0.250	0.000	0.667	0.000	0.000	0.250	0.743	0.583	0.000	0.744	0.000	0.000	0.000	0.883
Lights	15	136	2	0	153	0	0	4	25	3	0	32	0	0	2	98	7	0	107	0	0	0	330
% Lights	100.0%	95.1%	100.0%	0.0%	95.6%	0.0%	0.0%	100.0%	100.0%	100.0%	0.0%	100.0%	0.0%	0.0%	100.0%	91.6%	100.0%	0.0%	92.2%	0.0%	0.0%	0.0%	95.4%
Trucks	0	0	0	0	0	0	0	0	0	0	0	0	0	0	0	0	0	0	0	0	0	0	0
% Trucks	0.0%	0.0%	0.0%	0.0%	0.0%	0.0%	0.0%	0.0%	0.0%	0.0%	0.0%	0.0%	0.0%	0.0%	0.0%	0.0%	0.0%	0.0%	0.0%	0.0%	0.0%	0.0%	0.0%
Buses	0	7	0	0	7	0	0	0	0	0	0	0	0	0	0	9	0	0	9	0	0	0	16
% Buses	0.0%	4.9%	0.0%	0.0%	0.0%	0.0%	0.0%	0.0%	0.0%	0.0%	0.0%	0.0%	0.0%	0.0%	0.0%	8.4%	0.0%	0.0%	0.0%	0.0%	0.0%	0.0%	4.6%
Pedestrians	0	0	0	0	0	0	0	0	0	0	0	0	0	0	0	0	0	0	0	0	0	1	1
% Pedestrians	0.0%	0.0%	0.0%	0.0%	0.0%	0.0%	0.0%	0.0%	0.0%	0.0%	0.0%	0.0%	0.0%	0.0%	0.0%	0.0%	0.0%	0.0%	0.0%	0.0%	0.0%	100.0%	100.0%
Bicycles on Crosswalk	0	0	0	0	0	0	0	0	0	0	0	0	0	0	0	0	0	0	0	0	0	0	0
% Bicycles on Crosswalk	0.0%	0.0%	0.0%	0.0%	0.0%	0.0%	0.0%	0.0%	0.0%	0.0%	0.0%	0.0%	0.0%	0.0%	0.0%	0.0%	0.0%	0.0%	0.0%	0.0%	0.0%	0.0%	0.0%

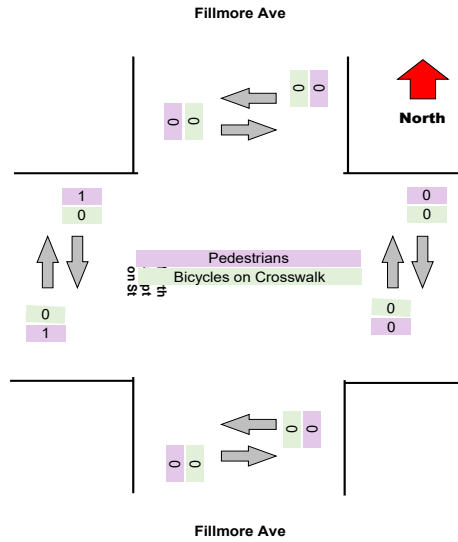
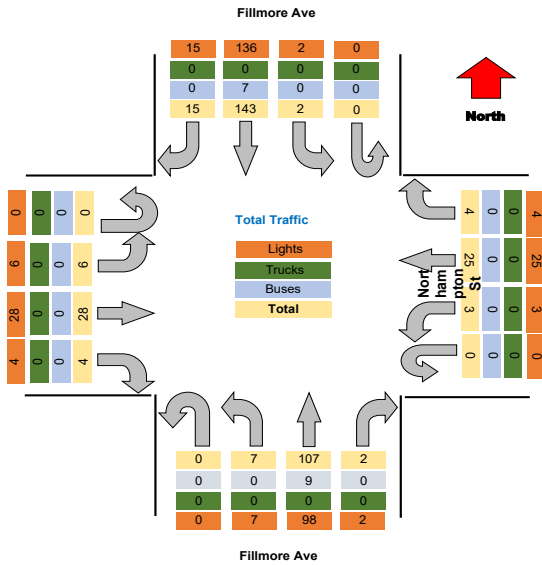

Project : VBH Malta NY  
Site : Site 4  
Location : 42.948550, -73.790036

TSTData.com

Survey Date : 2021-04-28, Wednesday

**Turning Movement Peak Hour Data (PM)**

4:15:00 PM

Leg Direction	Fillmore Ave												Northampton St												Total				
	Southbound						Westbound						Northbound						Eastbound										
	Right	Thru	Left	U-Turn	App Total	Peds CW	Peds CCW	Right	Thru	Left	U-Turn	App Total	Peds CW	Peds CCW	Right	Thru	Left	U-Turn	App Total	Peds CW	Peds CCW	Right	Thru	Left		U-Turn	App Total	Peds CW	Peds CCW
4:15:00 PM	4	62	1	0	67	0	0	0	8	3	0	11	0	0	1	65	7	0	73	0	0	2	15	3	0	20	1	1	171
4:30:00 PM	8	49	1	0	58	0	0	1	7	2	0	10	0	0	2	64	4	0	70	0	0	4	9	5	0	18	1	1	166
4:45:00 PM	9	60	2	0	71	0	0	5	6	2	0	13	0	0	4	63	1	0	68	0	0	2	14	7	0	23	2	1	175
5:00:00 PM	15	54	5	0	74	0	0	4	10	3	0	17	0	0	2	57	2	0	61	0	0	9	11	4	0	24	0	3	168
<b>Grand Total</b>	36	225	9	0	270	0	0	10	31	10	0	51	0	0	9	259	14	0	282	0	0	17	49	19	0	85	4	6	688
% Approach	13.3%	83.3%	3.3%	0.0%	0.0%	0.0%	0.0%	19.6%	60.8%	19.6%	0.0%	0.0%	0.0%	0.0%	3.2%	91.6%	5.0%	0.0%	0.0%	0.0%	0.0%	20.0%	57.6%	22.4%	0.0%	0.0%	0.0%	0.0%	
% Total	5.2%	32.7%	1.3%	0.0%	38.2%	0.0%	0.0%	1.5%	4.5%	1.5%	0.0%	7.4%	0.0%	0.0%	1.3%	37.6%	2.0%	0.0%	41.0%	0.0%	0.0%	2.5%	7.1%	2.8%	0.0%	12.4%	0.0%	0.0%	
PHF	0.600	0.907	0.450	0.000	0.912	0.000	0.000	0.500	0.775	0.833	0.000	0.750	0.000	0.000	0.563	0.966	0.500	0.000	0.866	0.000	0.000	0.472	0.817	0.679	0.000	0.885	0.000	0.000	0.925
Lights	35	217	9	0	261	0	0	10	31	10	0	51	0	0	9	255	14	0	278	0	0	17	48	19	0	84	0	0	674
% Lights	97.2%	96.4%	100.0%	0.0%	96.7%	0.0%	0.0%	100.0%	100.0%	100.0%	0.0%	100.0%	0.0%	0.0%	100.0%	98.5%	100.0%	0.0%	98.6%	0.0%	0.0%	100.0%	98.0%	100.0%	0.0%	98.8%	0.0%	0.0%	98.0%
Trucks	0	1	0	0	1	0	0	0	0	0	0	0	0	0	0	1	0	0	1	0	0	0	0	0	0	0	0	0	2
% Trucks	0.0%	0.4%	0.0%	0.0%	0.4%	0.0%	0.0%	0.0%	0.0%	0.0%	0.0%	0.0%	0.0%	0.0%	0.0%	0.4%	0.0%	0.0%	0.4%	0.0%	0.0%	0.0%	0.0%	0.0%	0.0%	0.0%	0.0%	0.0%	0.3%
Buses	1	7	0	0	8	0	0	0	0	0	0	0	0	0	0	2	0	0	2	0	0	0	1	0	0	1	0	0	11
% Buses	2.8%	3.1%	0.0%	0.0%	0.0%	0.0%	0.0%	0.0%	0.0%	0.0%	0.0%	0.0%	0.0%	0.0%	0.0%	0.8%	0.0%	0.0%	0.0%	0.0%	0.0%	0.0%	2.0%	0.0%	0.0%	0.0%	0.0%	0.0%	1.6%
Pedestrians	0	0	0	0	0	0	0	0	0	0	0	0	0	0	0	0	0	1	0	0	0	0	0	0	4	4	0		
% Pedestrians	0.0%	0.0%	0.0%	0.0%	0.0%	0.0%	0.0%	0.0%	0.0%	0.0%	0.0%	0.0%	0.0%	0.0%	0.0%	0.0%	0.0%	0.0%	0.0%	0.0%	0.0%	0.0%	0.0%	0.0%	0.0%	0.0%	100.0%	66.7%	0.0%
Bicycles on Crosswalk	0	0	0	0	0	0	0	0	0	0	0	0	0	0	0	0	0	0	0	0	0	0	0	0	0	2	0		
% Bicycles on Crosswalk	0.0%	0.0%	0.0%	0.0%	0.0%	0.0%	0.0%	0.0%	0.0%	0.0%	0.0%	0.0%	0.0%	0.0%	0.0%	0.0%	0.0%	0.0%	0.0%	0.0%	0.0%	0.0%	0.0%	0.0%	0.0%	0.0%	0.0%	33.3%	0.0%

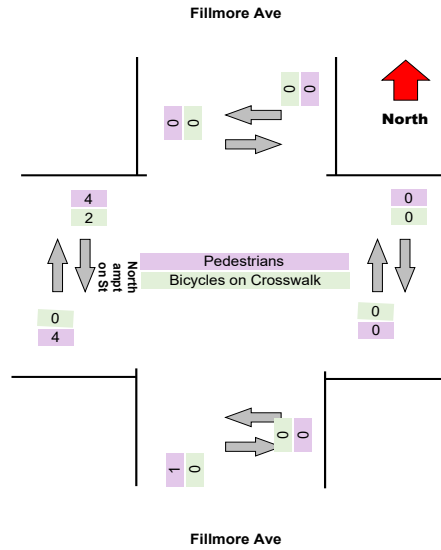
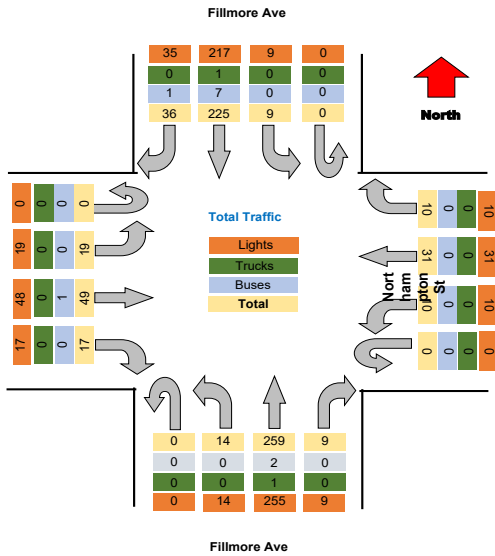





Project : VBH Malta NY  
 Site : Site 4  
 Location : 42.948550, -73.790036  
 Survey Date : 2021-04-28, Wednesday

### Turning Movement Data Plot

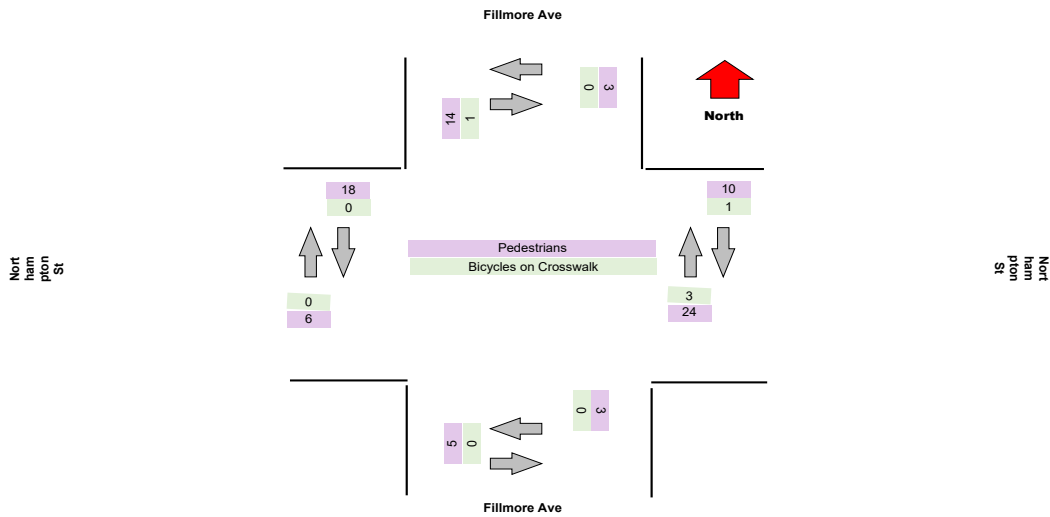
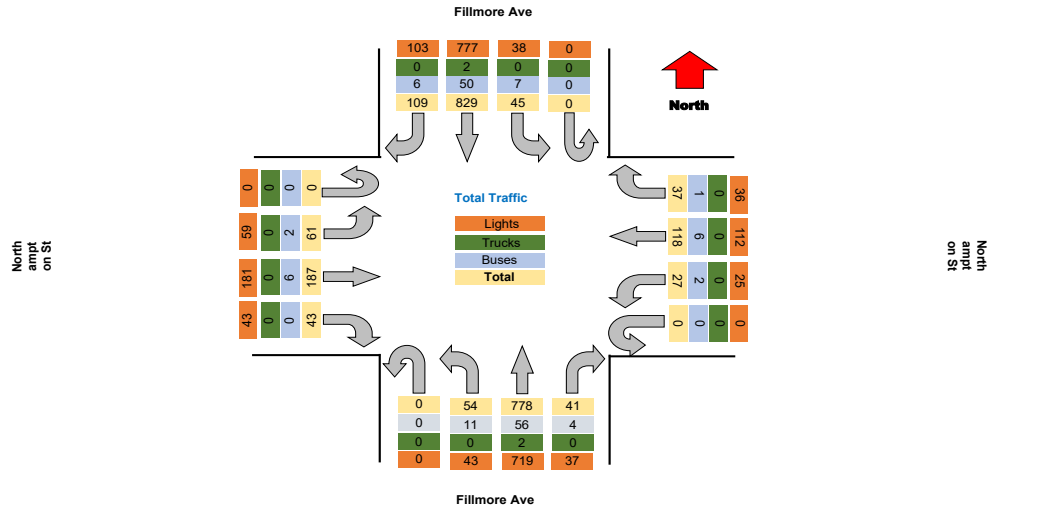

**Turning Movement Peak Hour Data (AM)**

7:30:00 AM

Leg Direction	Fillmore Ave						Northampton St						Fillmore Ave						Northampton St						Total					
	Southbound			Westbound			Northbound			Eastbound			Southbound			Westbound			Northbound			Eastbound								
Start Time	Right	Thru	Left	U-Turn	App Total	Peds CW	Peds CCW	Right	Thru	Left	U-Turn	App Total	Peds CW	Peds CCW	Right	Thru	Left	U-Turn	App Total	Peds CW	Peds CCW	Right	Thru	Left	U-Turn	App Total	Peds CW	Peds CCW		
7:30:00 AM	6	38	2	0	46	3	0	4	5	2	0	11	1	4	7	36	2	0	50	0	1	2	9	1	0	12	0	1	119	
7:45:00 AM	11	56	4	0	71	7	1	6	7	4	0	18	0	6	6	51	2	0	65	0	0	0	15	3	0	18	0	1	172	
8:00:00 AM	9	50	7	0	66	0	0	3	3	1	0	7	0	1	4	42	4	0	51	0	0	2	15	2	0	19	1	0	143	
8:15:00 AM	12	54	3	0	69	4	0	1	7	1	0	9	2	2	1	49	5	0	59	0	1	0	9	5	0	14	0	0	151	
<b>Grand Total</b>	<b>38</b>	<b>198</b>	<b>16</b>	<b>0</b>	<b>252</b>	<b>11</b>	<b>1</b>	<b>14</b>	<b>22</b>	<b>8</b>	<b>0</b>	<b>45</b>	<b>3</b>	<b>13</b>	<b>18</b>	<b>178</b>	<b>13</b>	<b>0</b>	<b>235</b>	<b>0</b>	<b>2</b>	<b>4</b>	<b>46</b>	<b>11</b>	<b>0</b>	<b>63</b>	<b>1</b>	<b>2</b>	<b>585</b>	
<b>% Approach</b>	15.1%	78.6%	6.3%	0.0%	0.0%	0.0%	0.0%	31.1%	48.9%	17.8%	0.0%	0.0%	0.0%	0.0%	8.0%	79.1%	5.8%	0.0%	0.0%	0.0%	0.0%	6.3%	76.2%	17.5%	0.0%	0.0%	0.0%	0.0%	0.0%	
<b>% Total</b>	6.5%	33.8%	2.7%	0.0%	43.1%	0.0%	0.0%	2.4%	3.8%	1.4%	0.0%	7.7%	0.0%	0.0%	3.1%	30.4%	2.2%	0.0%	38.5%	0.0%	0.0%	0.7%	8.2%	1.9%	0.0%	10.8%	0.0%	0.0%	0.0%	
<b>PHF</b>	0.792	0.884	0.571	0.000	0.887	0.000	0.000	0.583	0.786	0.500	0.000	0.625	0.000	0.000	0.643	0.873	0.650	0.000	0.865	0.000	0.000	0.500	0.800	0.550	0.000	0.829	0.000	0.000	0.850	
<b>Lights</b>	37	182	12	0	231	0	0	14	20	8	0	42	0	0	17	156	8	0	181	0	0	4	46	11	0	61	0	0	515	
<b>% Trucks</b>	0.0%	0.0%	0.0%	0.0%	0.0%	0.0%	0.0%	100.0%	90.9%	100.0%	0.0%	93.3%	0.0%	0.0%	0.0%	0.0%	0.0%	0.0%	80.4%	0.0%	0.0%	100.0%	95.8%	100.0%	0.0%	96.8%	0.0%	0.0%	88.0%	
<b>Buses</b>	1	16	4	0	21	0	0	0	2	0	0	2	0	0	1	22	5	0	28	0	0	0	2	0	0	2	0	0	53	
<b>% Buses</b>	2.6%	8.1%	25.0%	0.0%	0.0%	0.0%	0.0%	0.0%	9.1%	0.0%	0.0%	0.0%	0.0%	0.0%	5.6%	12.4%	38.5%	0.0%	0.0%	0.0%	0.0%	0.0%	4.2%	0.0%	0.0%	0.0%	0.0%	0.0%	9.1%	
<b>Pedestrians</b>	0	0	0	0	0	11	1	0	0	0	0	0	3	13	0	0	0	0	0	0	2	0	0	0	0	0	0	1	2	0
<b>% Pedestrians</b>	0.0%	0.0%	0.0%	0.0%	0.0%	100.0%	100.0%	0.0%	0.0%	0.0%	0.0%	0.0%	100.0%	100.0%	0.0%	0.0%	0.0%	0.0%	0.0%	0.0%	100.0%	100.0%	0.0%	0.0%	0.0%	0.0%	0.0%	100.0%	100.0%	0.0%
<b>Bicycles on Crosswalk</b>	0	0	0	0	0	0	0	0	0	0	0	0	0	0	0	0	0	0	0	0	0	0	0	0	0	0	0	0	0	0
<b>% Bicycles on Crosswalk</b>	0.0%	0.0%	0.0%	0.0%	0.0%	0.0%	0.0%	0.0%	0.0%	0.0%	0.0%	0.0%	0.0%	0.0%	0.0%	0.0%	0.0%	0.0%	0.0%	0.0%	0.0%	0.0%	0.0%	0.0%	0.0%	0.0%	0.0%	0.0%	0.0%	0.0%

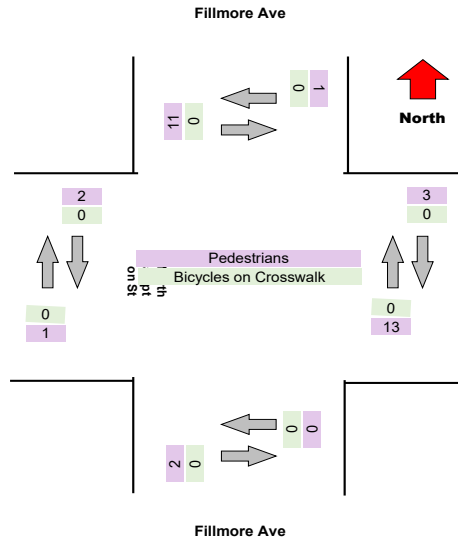
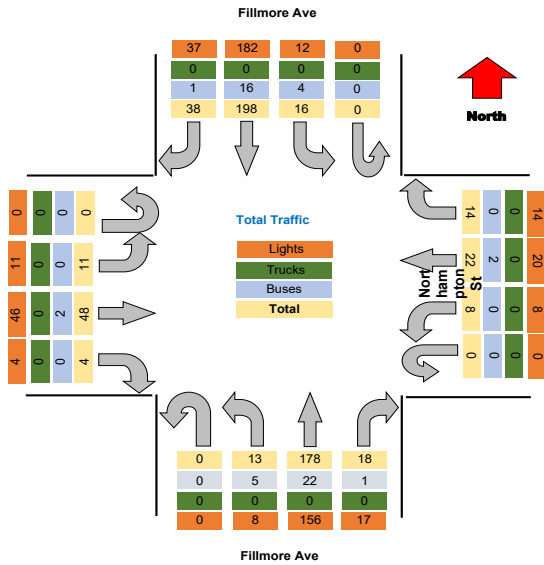

### Turning Movement Peak Hour Data (PM)

4:15:00 PM

Leg Direction	Fillmore Ave								Northampton St								Fillmore Ave								Northampton St								Total
	Southbound				Northbound				Westbound				Eastbound				Northbound				Eastbound												
	Right	Thru	Left	U-Turn	App Total	Peds CW	Peds CCW		Right	Thru	Left	U-Turn	App Total	Peds CW	Peds CCW		Right	Thru	Left	U-Turn	App Total	Peds CW	Peds CCW		Right	Thru	Left	U-Turn	App Total	Peds CW	Peds CCW		
4:15:00 PM	5	66	3	0	74	1	0	0	1	11	3	0	15	0	0	0	4	70	6	0	80	0	0	0	2	13	8	0	23	0	1	0	192
4:30:00 PM	9	72	4	0	85	0	0	0	2	12	0	0	14	0	0	0	4	61	8	0	73	2	2	0	7	16	5	0	28	1	5	0	200
4:45:00 PM	5	79	2	0	86	1	0	0	4	12	3	0	19	1	2	0	2	83	3	0	88	0	0	0	5	17	5	0	27	2	0	0	220
5:00:00 PM	10	61	4	0	75	0	0	0	2	9	4	0	15	0	0	0	1	66	1	0	68	0	0	0	5	17	3	0	25	1	1	0	183
<b>Grand Total</b>	<b>29</b>	<b>278</b>	<b>13</b>	<b>0</b>	<b>320</b>	<b>2</b>	<b>0</b>	<b>0</b>	<b>9</b>	<b>44</b>	<b>10</b>	<b>0</b>	<b>53</b>	<b>1</b>	<b>2</b>	<b>0</b>	<b>11</b>	<b>290</b>	<b>16</b>	<b>0</b>	<b>329</b>	<b>2</b>	<b>2</b>	<b>0</b>	<b>19</b>	<b>63</b>	<b>21</b>	<b>0</b>	<b>103</b>	<b>4</b>	<b>7</b>	<b>0</b>	<b>795</b>
% Approach	9.1%	86.9%	4.1%	0.0%	0.0%	0.0%	0.0%	0.0%	14.3%	69.8%	15.9%	0.0%	0.0%	0.0%	0.0%	0.0%	3.6%	90.6%	5.8%	0.0%	0.0%	0.0%	0.0%	0.0%	18.4%	61.2%	20.4%	0.0%	0.0%	0.0%	0.0%	0.0%	
% Total	3.6%	35.0%	1.6%	0.0%	40.3%	0.0%	0.0%	0.0%	1.1%	5.5%	1.3%	0.0%	7.9%	0.0%	0.0%	0.0%	1.4%	35.2%	2.3%	0.0%	38.9%	0.0%	0.0%	0.0%	2.4%	7.9%	2.6%	0.0%	13.0%	0.0%	0.0%	0.0%	
PHF	0.725	0.880	0.613	0.000	0.930	0.000	0.000	0.000	0.563	0.917	0.625	0.000	0.829	0.000	0.000	0.000	0.688	0.843	0.563	0.000	0.878	0.000	0.000	0.000	0.679	0.926	0.656	0.000	0.920	0.000	0.000	0.000	0.903
Lights	27	261	10	0	298	0	0	0	9	42	10	0	61	0	0	0	10	271	15	0	296	0	0	0	19	62	21	0	102	0	0	0	757
% Lights	93.1%	93.9%	76.9%	0.0%	93.1%	0.0%	0.0%	0.0%	100.0%	95.5%	100.0%	0.0%	96.8%	0.0%	0.0%	0.0%	80.9%	96.8%	83.3%	0.0%	95.8%	0.0%	0.0%	0.0%	100.0%	98.4%	100.0%	0.0%	99.0%	0.0%	0.0%	0.0%	
Trucks	0	1	0	0	1	0	0	0	0	0	0	0	0	0	0	0	0	0	0	0	0	0	0	0	0	0	0	0	0	0	0	0	1
% Trucks	0.0%	0.4%	0.0%	0.0%	0.3%	0.0%	0.0%	0.0%	0.0%	0.0%	0.0%	0.0%	0.0%	0.0%	0.0%	0.0%	0.0%	0.0%	0.0%	0.0%	0.0%	0.0%	0.0%	0.0%	0.0%	0.0%	0.0%	0.0%	0.0%	0.0%	0.0%	0.0%	
Buses	2	16	3	0	21	0	0	0	0	2	0	0	2	0	0	0	1	9	3	0	13	0	0	0	0	1	0	0	1	0	0	0	37
% Buses	6.9%	5.8%	23.1%	0.0%	0.0%	0.0%	0.0%	0.0%	0.0%	4.5%	0.0%	0.0%	0.0%	0.0%	0.0%	0.0%	9.1%	3.2%	16.7%	0.0%	0.0%	0.0%	0.0%	0.0%	0.0%	1.6%	0.0%	0.0%	0.0%	0.0%	0.0%	0.0%	4.7%
Pedestrians	0	0	0	0	0	1	0	0	0	0	0	0	1	1	0	0	0	0	0	0	2	2	0	0	0	0	0	0	0	4	7	0	7
% Pedestrians	0.0%	0.0%	0.0%	0.0%	0.0%	50.0%	0.0%	0.0%	0.0%	0.0%	0.0%	0.0%	0.0%	100.0%	50.0%	0.0%	0.0%	0.0%	0.0%	0.0%	0.0%	100.0%	100.0%	0.0%	0.0%	100.0%	100.0%	0.0%	0.0%				
Bicycles on Crosswalk	0	0	0	0	0	1	0	0	0	0	0	0	0	1	0	0	0	0	0	0	0	0	0	0	0	0	0	0	0	0	0	0	0
% Bicycles on Crosswalk	0.0%	0.0%	0.0%	0.0%	0.0%	50.0%	0.0%	0.0%	0.0%	0.0%	0.0%	0.0%	0.0%	0.0%	50.0%	0.0%	0.0%	0.0%	0.0%	0.0%	0.0%	0.0%	0.0%	0.0%	0.0%	0.0%	0.0%	0.0%	0.0%	0.0%	0.0%	0.0%	

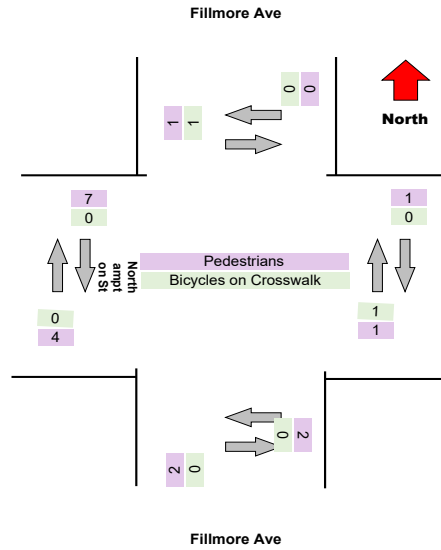
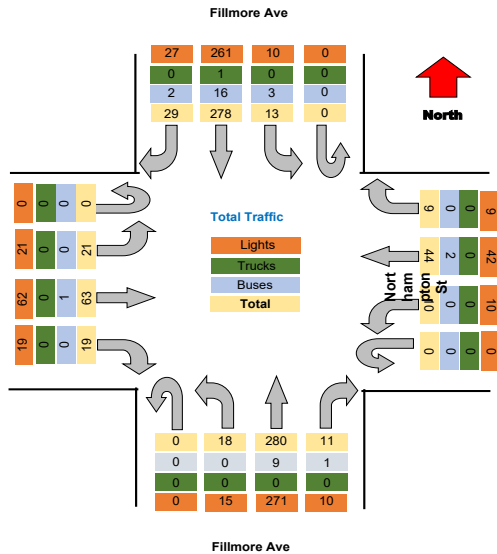

Project : VBH Malta NY  
 Site : Site 4  
 Location : 42.948550, -73.790036

TSTData.com

Survey Date : 2021-04-28, Wednesday

Project	LaBella
Project Code	LaBella
Site Name	19
Legs and Movements	All Processed Legs & Move
Bin Size	15 minutes
Survey Date	2021-11-04, Thursday
Location	19
Latitude and Longitude	42.907282, -78.839084

	Start	End	PHF
Forced Peak AM	2021/11/04 07:30:00	2021/11/04 08:30:00	0.92
Forced Peak PM	2021/11/04 16:30:00	2021/11/04 17:30:00	0.92
AM Peak	2021/11/04 07:30:00	2021/11/04 08:30:00	0.92
PM Peak	2021/11/04 16:15:00	2021/11/04 17:15:00	0.93

### Turning Movement Data

Leg Direction	Fillmore Ave							Genesee St							Fillmore Ave							Genesee St							Total
	Southbound							Westbound							Northbound							Eastbound							
	Right	Thru	Left	U-Turn	App Total	Peds CV	Peds CCV	Right	Thru	Left	U-Turn	App Total	Peds CV	Peds CCV	Right	Thru	Left	U-Turn	App Total	Peds CV	Peds CCV	Right	Thru	Left	U-Turn	App Total	Peds CV	Peds CCV	
6:30:00 AM	2	19	1	0	<b>22</b>	0	0	0	1	0	0	<b>2</b>	0	1	2	10	0	0	<b>13</b>	0	1	0	1	0	0	<b>1</b>	0	0	<b>38</b>
6:45:00 AM	3	23	1	0	<b>27</b>	0	0	0	4	0	0	<b>4</b>	0	0	0	16	0	0	<b>16</b>	0	0	2	3	0	0	<b>5</b>	0	0	<b>52</b>
Hourly Total	5	42	2	0	<b>49</b>	0	0	0	5	1	0	<b>6</b>	0	1	2	26	0	0	<b>29</b>	0	1	2	4	0	0	<b>6</b>	0	0	<b>99</b>
7:00:00 AM	5	25	2	0	<b>32</b>	2	1	0	6	0	0	<b>7</b>	3	1	3	21	1	0	<b>29</b>	0	0	0	2	0	0	<b>2</b>	0	0	<b>70</b>
7:15:00 AM	5	22	1	0	<b>28</b>	0	1	1	5	0	0	<b>7</b>	4	4	5	23	1	0	<b>37</b>	0	0	3	10	2	0	<b>15</b>	1	1	<b>87</b>
7:30:00 AM	11	46	5	0	<b>62</b>	3	0	1	7	4	0	<b>12</b>	0	7	7	30	1	0	<b>45</b>	0	0	1	9	1	0	<b>11</b>	0	0	<b>130</b>
7:45:00 AM	9	47	3	0	<b>59</b>	3	2	3	10	3	0	<b>18</b>	0	7	6	39	1	0	<b>53</b>	0	0	1	19	5	0	<b>25</b>	0	2	<b>155</b>
Hourly Total	30	140	11	0	<b>181</b>	8	4	5	28	7	0	<b>44</b>	7	19	21	113	4	0	<b>164</b>	0	0	5	40	8	0	<b>53</b>	1	3	<b>442</b>
8:00:00 AM	12	67	6	0	<b>85</b>	1	0	3	4	2	0	<b>9</b>	2	4	2	44	3	0	<b>55</b>	0	0	4	14	2	0	<b>20</b>	0	0	<b>169</b>
8:15:00 AM	7	61	8	0	<b>76</b>	0	0	1	9	2	0	<b>12</b>	1	2	3	46	3	0	<b>55</b>	0	0	3	12	8	0	<b>23</b>	0	0	<b>166</b>
Hourly Total	19	128	14	0	<b>161</b>	1	0	4	13	4	0	<b>21</b>	3	6	5	90	6	0	<b>110</b>	0	0	7	26	10	0	<b>43</b>	0	0	<b>335</b>
4:00:00 PM	6	68	1	0	<b>75</b>	0	0	3	8	4	0	<b>15</b>	0	2	2	72	3	0	<b>77</b>	1	0	4	16	7	0	<b>27</b>	0	0	<b>194</b>
4:15:00 PM	9	84	2	0	<b>95</b>	0	0	1	9	2	0	<b>12</b>	0	1	2	71	6	0	<b>79</b>	0	1	3	25	2	0	<b>30</b>	2	1	<b>216</b>
4:30:00 PM	12	55	4	0	<b>71</b>	1	0	5	9	4	0	<b>18</b>	1	2	3	78	4	0	<b>85</b>	1	0	6	15	5	0	<b>26</b>	0	1	<b>200</b>
4:45:00 PM	13	62	0	0	<b>75</b>	0	0	4	9	4	0	<b>17</b>	0	3	1	74	5	0	<b>80</b>	0	0	5	17	8	0	<b>30</b>	1	0	<b>222</b>
Hourly Total	40	289	7	0	<b>336</b>	1	0	13	35	14	0	<b>62</b>	1	8	8	295	18	0	<b>321</b>	2	1	18	73	22	0	<b>113</b>	3	2	<b>832</b>
5:00:00 PM	8	65	0	0	<b>73</b>	0	0	4	5	3	0	<b>12</b>	2	2	2	75	3	0	<b>80</b>	0	0	6	23	3	0	<b>32</b>	0	1	<b>187</b>
5:15:00 PM	7	75	3	0	<b>85</b>	0	0	2	9	4	0	<b>15</b>	0	0	2	74	4	0	<b>80</b>	0	0	7	22	2	0	<b>31</b>	2	0	<b>211</b>
5:30:00 PM	9	67	1	0	<b>77</b>	0	0	3	8	1	0	<b>12</b>	0	0	2	55	3	0	<b>60</b>	0	0	7	15	1	0	<b>23</b>	0	2	<b>172</b>
5:45:00 PM	14	60	2	0	<b>76</b>	0	0	5	7	0	0	<b>12</b>	2	0	1	52	3	0	<b>56</b>	0	0	5	16	3	0	<b>24</b>	0	0	<b>168</b>
Hourly Total	38	257	6	0	<b>301</b>	0	1	14	29	8	0	<b>51</b>	4	2	7	256	13	0	<b>276</b>	0	0	25	76	9	0	<b>110</b>	2	3	<b>738</b>
Grand Total	132	856	40	0	<b>1028</b>	10	5	36	110	34	0	<b>184</b>	15	38	43	780	41	0	<b>900</b>	2	2	57	219	49	0	<b>325</b>	6	10	<b>2437</b>
% Approach	12.8%	83.3%	3.9%	0.0%	<b>0.0%</b>	0.0%	0.0%	19.6%	59.8%	18.5%	0.0%	<b>0.0%</b>	0.0%	0.0%	4.8%	86.7%	4.6%	0.0%	<b>0.0%</b>	0.0%	0.0%	17.5%	67.4%	15.1%	0.0%	<b>0.0%</b>	0.0%	0.0%	<b>0.0%</b>
% Total	5.4%	35.1%	1.6%	0.0%	<b>42.2%</b>	0.0%	0.0%	1.5%	4.5%	1.4%	0.0%	<b>7.6%</b>	0.0%	0.0%	1.8%	32.0%	1.7%	0.0%	<b>36.9%</b>	0.0%	0.0%	2.3%	9.0%	2.0%	0.0%	<b>13.3%</b>	0.0%	0.0%	<b>0.0%</b>
Lights	127	806	32	0	<b>965</b>	0	0	35	106	34	0	<b>175</b>	0	0	40	727	33	0	<b>800</b>	0	0	55	215	47	0	<b>317</b>	0	0	<b>2287</b>
% Lights	96.2%	94.2%	80.0%	0.0%	<b>93.9%</b>	0.0%	0.0%	97.2%	96.4%	100.0%	0.0%	<b>95.1%</b>	0.0%	0.0%	93.0%	93.2%	80.5%	0.0%	<b>88.9%</b>	0.0%	0.0%	96.5%	98.2%	95.9%	0.0%	<b>97.8%</b>	0.0%	0.0%	<b>92.6%</b>
Trucks	0	2	0	0	<b>2</b>	0	0	0	0	0	0	<b>0</b>	0	0	0	1	0	0	<b>1</b>	0	0	0	0	0	0	<b>0</b>	0	0	<b>3</b>
% Trucks	0.0%	0.2%	0.0%	0.0%	<b>0.2%</b>	0.0%	0.0%	0.0%	0.0%	0.0%	0.0%	<b>0.0%</b>	0.0%	0.0%	0.0%	0.1%	0.0%	0.0%	<b>0.1%</b>	0.0%	0.0%	0.0%	0.0%	0.0%	0.0%	<b>0.0%</b>	0.0%	0.0%	<b>0.1%</b>
Buses	5	48	8	0	<b>61</b>	0	0	1	4	0	0	<b>5</b>	0	0	3	52	8	0	<b>63</b>	0	0	2	4	2	0	<b>8</b>	0	0	<b>137</b>
% Buses	3.8%	5.6%	20.0%	0.0%	<b>0.0%</b>	0.0%	0.0%	0.0%	3.6%	0.0%	0.0%	<b>0.0%</b>	0.0%	0.0%	7.0%	6.7%	19.5%	0.0%	<b>0.0%</b>	0.0%	0.0%	3.5%	1.8%	4.1%	0.0%	<b>0.0%</b>	0.0%	0.0%	<b>5.6%</b>
Pedestrians	0	0	0	0	<b>0</b>	10	5	0	0	0	0	<b>0</b>	13	38	0	0	0	0	<b>0</b>	2	2	0	0	0	0	<b>0</b>	6	9	<b>0</b>
% Pedestrians	0.0%	0.0%	0.0%	0.0%	<b>0.0%</b>	100.0%	100.0%	0.0%	0.0%	0.0%	0.0%	<b>0.0%</b>	86.7%	100.0%	0.0%	0.0%	0.0%	0.0%	<b>0.0%</b>	100.0%	100.0%	0.0%	0.0%	0.0%	0.0%	<b>0.0%</b>	100.0%	80.0%	<b>0.0%</b>
Bicycles on Crosswalk	0	0	0	0	<b>0</b>	0	0	0	0	0	0	<b>0</b>	2	0	0	0	0	0	<b>0</b>	0	0	0	0	0	0	<b>0</b>	0	1	<b>0</b>
% Bicycles on Crosswalk	0.0%	0.0%	0.0%	0.0%	<b>0.0%</b>	0.0%	0.0%	0.0%	0.0%	0.0%	0.0%	<b>0.0%</b>	13.3%	0.0%	0.0%	0.0%	0.0%	0.0%	<b>0.0%</b>	0.0%	0.0%	0.0%	0.0%	0.0%	0.0%	<b>0.0%</b>	0.0%	10.0%	<b>0.0%</b>

**Turning Movement Data Plot**

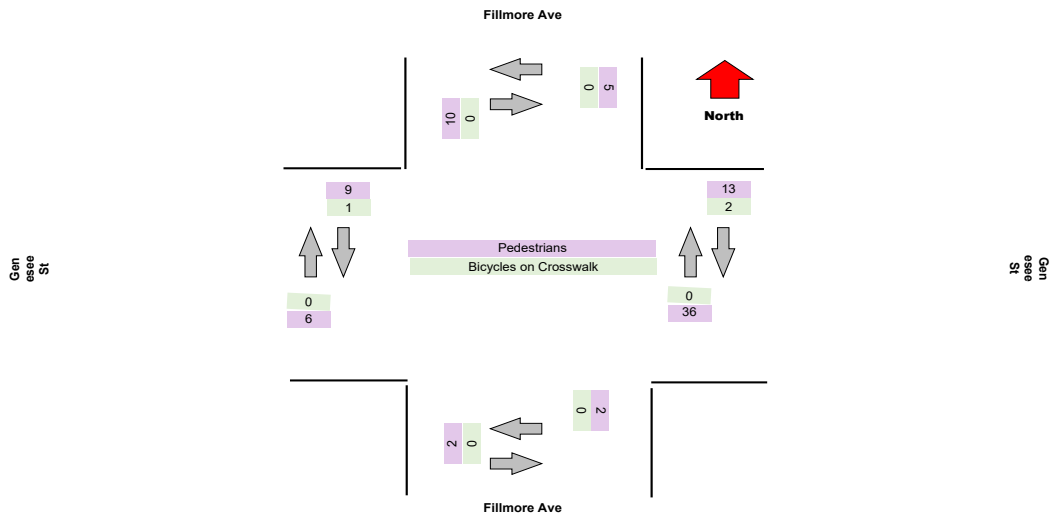
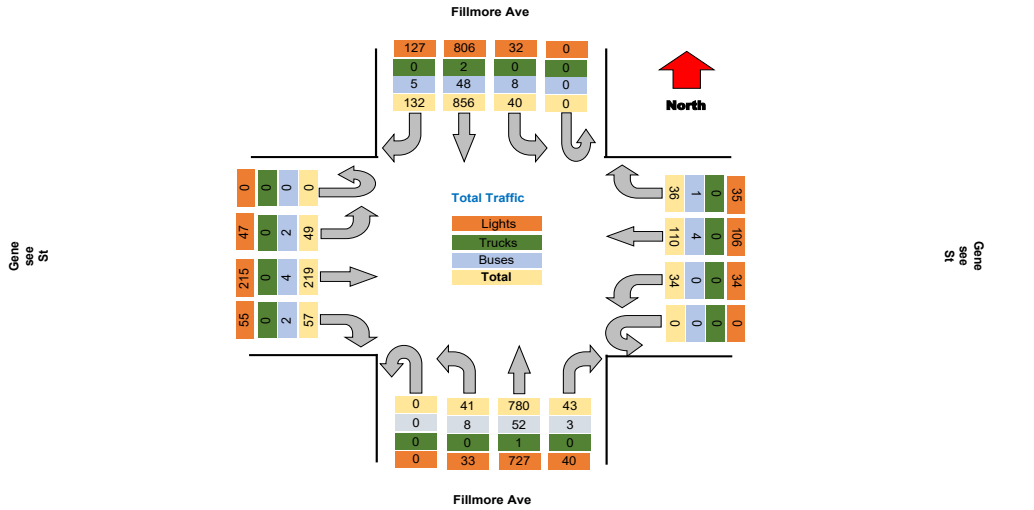

Project : VBH Malta NY  
Site : Site 4  
Location : 42.948550, -73.790036

TSTData.com

Survey Date : 2021-04-28, Wednesday

### Turning Movement Peak Hour Data (AM)

7:30:00 AM

Leg Direction	Fillmore Ave						Genesee St						Fillmore Ave						Genesee St						Total					
	Southbound			Northbound			Westbound			Eastbound			Northbound			Eastbound														
Start Time	Right	Thru	Left	U-Turn	App Total	Peds CW	Peds CCW	Right	Thru	Left	U-Turn	App Total	Peds CW	Peds CCW	Right	Thru	Left	U-Turn	App Total	Peds CW	Peds CCW	Right	Thru	Left	U-Turn	App Total	Peds CW	Peds CCW		
7:30:00 AM	11	46	5	0	62	3	0	1	7	4	0	12	0	7	7	30	1	0	45	0	0	1	9	1	0	11	0	0	130	
7:45:00 AM	9	47	3	0	59	3	2	3	10	3	0	16	0	7	6	39	1	0	53	0	0	1	19	5	0	25	0	2	155	
8:00:00 AM	12	67	6	0	85	1	0	3	4	2	0	9	2	4	2	44	3	0	55	0	0	4	14	2	0	20	0	0	169	
8:15:00 AM	7	61	8	0	76	0	0	1	9	2	0	12	1	2	3	46	3	0	55	0	0	3	12	8	0	23	0	0	166	
<b>Grand Total</b>	<b>39</b>	<b>221</b>	<b>22</b>	<b>0</b>	<b>282</b>	<b>7</b>	<b>2</b>	<b>8</b>	<b>30</b>	<b>11</b>	<b>0</b>	<b>31</b>	<b>3</b>	<b>20</b>	<b>18</b>	<b>159</b>	<b>8</b>	<b>0</b>	<b>238</b>	<b>0</b>	<b>0</b>	<b>9</b>	<b>54</b>	<b>16</b>	<b>0</b>	<b>79</b>	<b>3</b>	<b>2</b>	<b>620</b>	
% Approach	13.8%	76.4%	7.6%	0.0%	0.0%	0.0%	0.0%	15.7%	58.8%	21.6%	0.0%	0.0%	0.0%	0.0%	8.7%	76.4%	3.8%	0.0%	0.0%	0.0%	0.0%	11.4%	66.4%	20.3%	0.0%	0.0%	0.0%	0.0%	0.0%	
% Total	6.3%	35.6%	3.5%	0.0%	45.5%	0.0%	0.0%	1.3%	4.8%	1.8%	0.0%	8.2%	0.0%	0.0%	2.9%	25.6%	1.3%	0.0%	33.5%	0.0%	0.0%	1.5%	8.7%	2.6%	0.0%	12.7%	0.0%	0.0%	0.0%	
PHF	0.813	0.825	0.688	0.000	0.829	0.000	0.000	0.667	0.750	0.688	0.000	0.708	0.000	0.000	0.643	0.864	0.667	0.000	0.845	0.000	0.000	0.563	0.711	0.500	0.000	0.790	0.000	0.000	0.917	
Lights	38	207	17	0	262	0	0	8	28	11	0	47	0	0	18	140	4	0	162	0	0	9	52	16	0	77	0	0	548	
% Lights	97.4%	93.7%	77.3%	0.0%	92.9%	0.0%	0.0%	100.0%	93.3%	100.0%	0.0%	92.2%	0.0%	0.0%	100.0%	88.1%	50.0%	0.0%	77.9%	0.0%	0.0%	100.0%	96.3%	100.0%	0.0%	97.5%	0.0%	0.0%	88.4%	
Trucks	0	0	0	0	0	0	0	0	0	0	0	0	0	0	0	0	0	0	0	0	0	0	0	0	0	0	0	0	0	
% Trucks	0.0%	0.0%	0.0%	0.0%	0.0%	0.0%	0.0%	0.0%	0.0%	0.0%	0.0%	0.0%	0.0%	0.0%	0.0%	0.0%	0.0%	0.0%	0.0%	0.0%	0.0%	0.0%	0.0%	0.0%	0.0%	0.0%	0.0%	0.0%	0.0%	
Buses	1	14	5	0	20	0	0	2	2	0	0	2	0	0	0	19	4	0	23	0	0	0	2	0	0	2	0	0	47	
% Buses	2.6%	6.3%	22.7%	0.0%	0.0%	0.0%	0.0%	0.0%	6.7%	0.0%	0.0%	0.0%	0.0%	0.0%	0.0%	11.9%	50.0%	0.0%	0.0%	0.0%	0.0%	0.0%	3.7%	0.0%	0.0%	0.0%	0.0%	0.0%	7.6%	
Pedestrians	0	0	0	0	0	7	2	0	0	0	0	3	20	0	0	0	0	0	0	0	0	0	0	0	0	0	0	1	0	
% Pedestrians	0.0%	0.0%	0.0%	0.0%	0.0%	100.0%	100.0%	0.0%	0.0%	0.0%	0.0%	0.0%	100.0%	100.0%	0.0%	0.0%	0.0%	0.0%	0.0%	0.0%	0.0%	0.0%	0.0%	0.0%	0.0%	0.0%	0.0%	0.0%	50.0%	0.0%
Bicycles on Crosswalk	0	0	0	0	0	0	0	0	0	0	0	0	0	0	0	0	0	0	0	0	0	0	0	0	0	0	0	1	0	
% Bicycles on Crosswalk	0.0%	0.0%	0.0%	0.0%	0.0%	0.0%	0.0%	0.0%	0.0%	0.0%	0.0%	0.0%	0.0%	0.0%	0.0%	0.0%	0.0%	0.0%	0.0%	0.0%	0.0%	0.0%	0.0%	0.0%	0.0%	0.0%	0.0%	50.0%	0.0%	

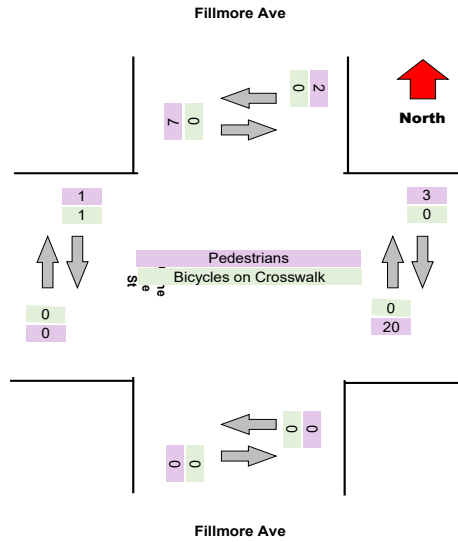
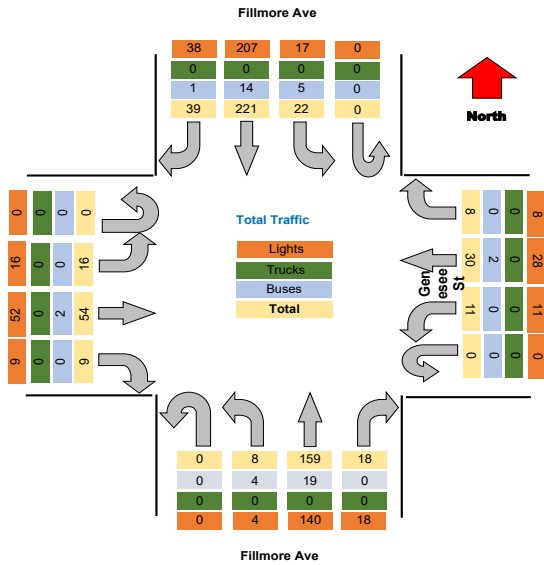

### Turning Movement Peak Hour Data (PM)

4:15:00 PM

Leg Direction	Fillmore Ave										Genesee St										Total														
	Southbound					Westbound					Northbound					Eastbound																			
	Right	Thru	Left	U-Turn	App Total	Right	Thru	Left	U-Turn	App Total	Right	Thru	Left	U-Turn	App Total	Right	Thru	Left	U-Turn	App Total															
4:15:00 PM	9	84	2	0	95	0	0	0	0	0	1	9	2	0	12	0	0	0	0	0	2	71	6	0	79	0	0	0	0	0	30	2	1	1	33
4:30:00 PM	12	55	4	0	71	1	0	0	0	1	5	9	4	0	18	1	2	0	0	3	3	78	4	0	85	1	0	0	0	1	6	15	5	0	26
4:45:00 PM	13	82	0	0	95	0	0	0	0	0	4	9	4	0	17	0	3	0	0	3	1	74	5	0	80	0	0	0	0	0	5	17	8	0	30
5:00:00 PM	8	55	0	0	63	0	0	0	0	0	4	5	3	0	12	2	2	0	0	4	2	75	3	0	80	0	0	0	0	0	6	23	3	0	32
<b>Grand Total</b>	<b>42</b>	<b>276</b>	<b>6</b>	<b>0</b>	<b>324</b>	<b>1</b>	<b>9</b>	<b>2</b>	<b>0</b>	<b>12</b>	<b>14</b>	<b>32</b>	<b>13</b>	<b>0</b>	<b>59</b>	<b>3</b>	<b>6</b>	<b>0</b>	<b>0</b>	<b>9</b>	<b>8</b>	<b>286</b>	<b>14</b>	<b>0</b>	<b>307</b>	<b>1</b>	<b>1</b>	<b>1</b>	<b>0</b>	<b>3</b>	<b>20</b>	<b>80</b>	<b>18</b>	<b>0</b>	<b>118</b>
% Approach	13.0%	85.2%	1.9%	0.0%	0.0%	23.7%	54.2%	22.0%	0.0%	0.0%	2.5%	92.0%	5.6%	0.0%	0.0%	16.9%	67.8%	15.3%	0.0%	0.0%	2.4%	9.7%	2.2%	0.0%	14.3%	0.0%	0.0%	0.0%	0.0%	0.0%					
% Total	5.1%	33.5%	0.7%	0.0%	38.3%	1.7%	3.9%	1.6%	0.0%	7.2%	1.0%	36.1%	2.2%	0.0%	39.3%	0.0%	0.0%	0.0%	0.0%	0.0%	2.4%	9.7%	2.2%	0.0%	14.3%	0.0%	0.0%	0.0%	0.0%	0.0%					
PHF	0.808	0.821	0.375	0.000	0.853	0.700	0.889	0.813	0.000	0.819	0.667	0.955	0.750	0.000	0.853	0.833	0.800	0.563	0.000	0.922	0.000	0.000	0.000	0.000	0.000	0.929									
Lights	42	260	4	0	306	14	32	13	0	59	7	286	14	0	307	20	79	18	0	117	0	0	0	0	0	789									
% Lights	100.0%	94.2%	66.7%	0.0%	94.4%	100.0%	100.0%	100.0%	0.0%	100.0%	87.5%	96.0%	77.8%	0.0%	94.8%	100.0%	98.8%	100.0%	0.0%	99.2%	0.0%	0.0%	0.0%	0.0%	0.0%	95.6%									
Trucks	0	1	0	0	1	0	0	0	0	0	0	0	0	0	0	0	0	0	0	0	0	0	0	0	0	0	0	0	0	0	1				
% Trucks	0.0%	0.4%	0.0%	0.0%	0.3%	0.0%	0.0%	0.0%	0.0%	0.0%	0.0%	0.0%	0.0%	0.0%	0.0%	0.0%	0.0%	0.0%	0.0%	0.0%	0.0%	0.0%	0.0%	0.0%	0.0%	0.1%									
Buses	0	15	2	0	17	0	0	0	0	0	1	12	4	0	17	0	1	0	0	1	0	1	0	0	1	0	0	0	0	0	35				
% Buses	0.0%	5.4%	33.3%	0.0%	0.0%	0.0%	0.0%	0.0%	0.0%	0.0%	12.5%	4.0%	22.2%	0.0%	0.0%	0.0%	1.3%	0.0%	0.0%	0.0%	0.0%	0.0%	0.0%	0.0%	0.0%	4.2%									
Pedestrians	0	0	0	0	0	1	1	0	0	2	0	0	0	0	0	1	1	0	0	2	0	0	0	0	0	3	3	0	0	6					
% Pedestrians	0.0%	0.0%	0.0%	0.0%	0.0%	100.0%	100.0%	0.0%	0.0%	66.7%	0.0%	0.0%	0.0%	0.0%	0.0%	100.0%	100.0%	0.0%	0.0%	0.0%	0.0%	0.0%	0.0%	0.0%	0.0%	100.0%	100.0%	0.0%	0.0%	0.0%					
Bicycles on Crosswalk	0	0	0	0	0	0	0	0	0	1	0	0	0	0	0	0	0	0	0	0	0	0	0	0	0	0	0	0	0	0	1				
% Bicycles on Crosswalk	0.0%	0.0%	0.0%	0.0%	0.0%	0.0%	0.0%	0.0%	0.0%	0.0%	0.0%	0.0%	0.0%	0.0%	0.0%	0.0%	0.0%	0.0%	0.0%	0.0%	0.0%	0.0%	0.0%	0.0%	0.0%	0.0%	0.0%	0.0%	0.0%	0.0%					

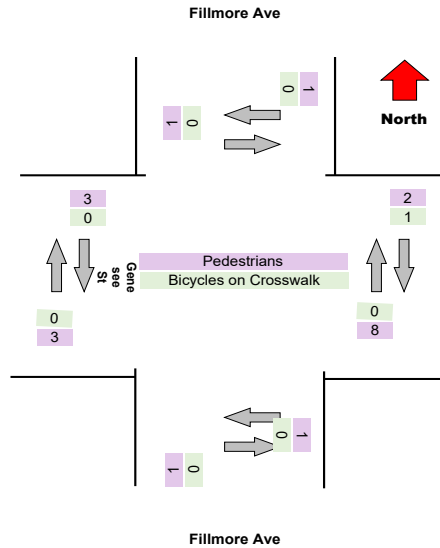
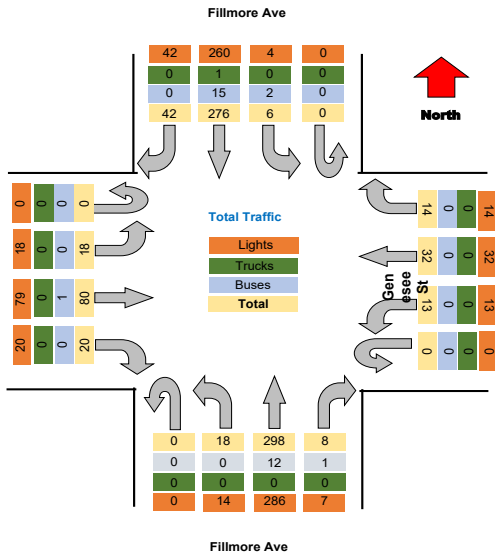





Turning Movement Data Plot

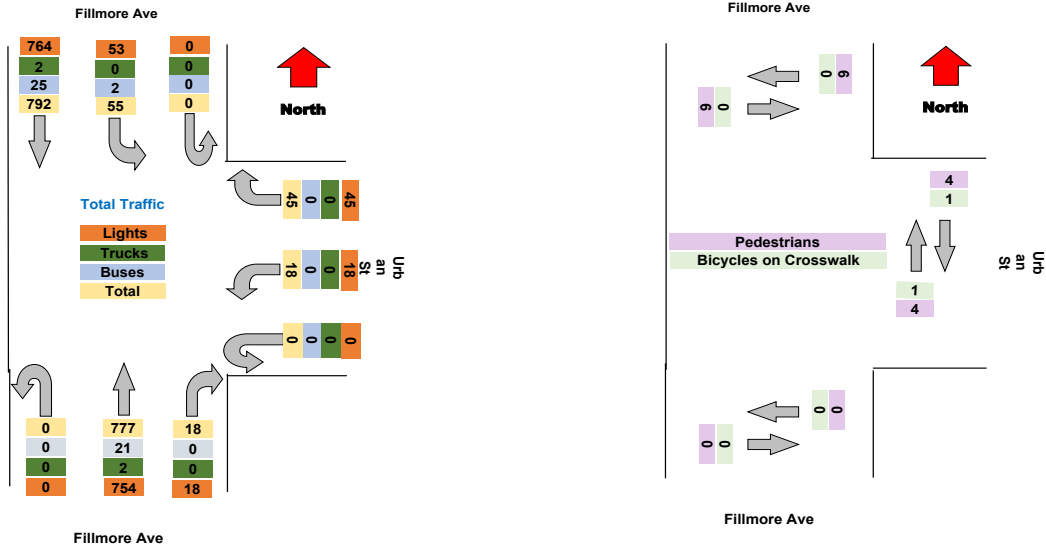

Turning Movement Peak Hour Data (AM)  
 7:30:00 AM

Leg Direction	Fillmore Ave Southbound						Urban St Westbound						Fillmore Ave Northbound						Total
	Thru	Left	U-Turn	App Total	Peds CW	Peds CCW	Right	Left	U-Turn	App Total	Peds CW	Peds CCW	Right	Thru	U-Turn	App Total	Peds CW	Peds CCW	
7:30:00 AM	26	2	0	28	0	0	3	0	0	3	0	1	3	26	0	30	0	0	61
7:45:00 AM	42	5	0	47	0	0	1	0	0	1	0	0	1	37	0	38	0	0	86
8:00:00 AM	48	4	0	52	0	0	2	0	0	2	1	0	0	29	0	30	0	0	84
8:15:00 AM	45	2	0	47	0	0	5	1	0	6	0	0	1	28	0	29	0	0	82
<b>Grand Total</b>	161	13	0	174	0	0	11	1	0	12	1	1	5	120	0	127	0	0	313
% Approach	92.5%	7.5%	0.0%	0.0%	0.0%	0.0%	91.7%	8.3%	0.0%	0.0%	0.0%	0.0%	3.9%	94.5%	0.0%	0.0%	0.0%	0.0%	
% Total	51.4%	4.2%	0.0%	55.6%	0.0%	0.0%	3.5%	0.3%	0.0%	3.8%	0.0%	0.0%	1.6%	38.3%	0.0%	40.6%	0.0%	0.0%	
PHF	0.839	0.650	0.000	0.837	0.000	0.000	0.550	0.250	0.000	0.500	0.000	0.000	0.417	0.811	0.000	0.836	0.000	0.000	0.910
Lights	154	13	0	167	0	0	11	1	0	12	0	0	5	111	0	116	0	0	295
% Lights	95.7%	100.0%	0.0%	96.0%	0.0%	0.0%	100.0%	100.0%	0.0%	100.0%	0.0%	0.0%	100.0%	92.5%	0.0%	91.3%	0.0%	0.0%	94.2%
Trucks	0	0	0	0	0	0	0	0	0	0	0	0	0	0	0	0	0	0	0
% Trucks	0.0%	0.0%	0.0%	0.0%	0.0%	0.0%	0.0%	0.0%	0.0%	0.0%	0.0%	0.0%	0.0%	0.0%	0.0%	0.0%	0.0%	0.0%	0.0%
Buses	7	0	0	7	0	0	0	0	0	0	0	0	0	9	0	9	0	0	16
% Buses	4.3%	0.0%	0.0%	0.0%	0.0%	0.0%	0.0%	0.0%	0.0%	0.0%	0.0%	0.0%	0.0%	7.5%	0.0%	0.0%	0.0%	0.0%	5.1%
Pedestrians	0	0	0	0	0	0	0	0	0	0	0	1	0	0	0	0	0	0	0
% Pedestrians	0.0%	0.0%	0.0%	0.0%	0.0%	0.0%	0.0%	0.0%	0.0%	0.0%	0.0%	100.0%	0.0%	0.0%	0.0%	0.0%	0.0%	0.0%	0.0%
Bicycles on Crosswalk	0	0	0	0	0	0	0	0	0	0	1	0	0	0	0	0	0	0	0
% Bicycles on Crosswalk	0.0%	0.0%	0.0%	0.0%	0.0%	0.0%	0.0%	0.0%	0.0%	0.0%	100.0%	0.0%	0.0%	0.0%	0.0%	0.0%	0.0%	0.0%	0.0%

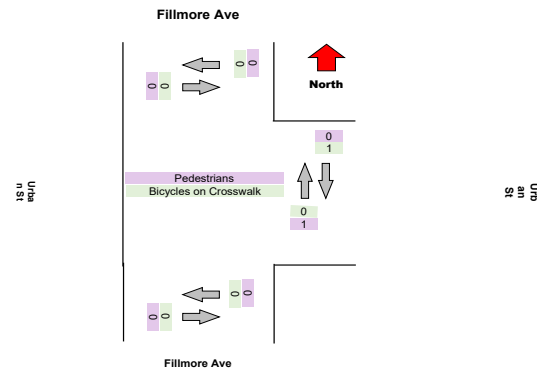
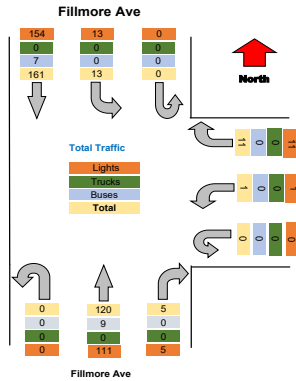

Turning Movement Peak Hour Data (PM)  
 4:45:00 PM

Leg Direction	Fillmore Ave Southbound						Urban St Westbound						Fillmore Ave Northbound						Total
	Thru	Left	U-Turn	App Total	Peds CW	Peds CCW	Right	Left	U-Turn	App Total	Peds CW	Peds CCW	Right	Thru	U-Turn	App Total	Peds CW	Peds CCW	
4:45:00 PM	67	4	0	71	0	0	1	1	0	2	0	0	4	79	0	83	0	0	156
5:00:00 PM	70	10	0	80	2	2	2	2	0	4	0	0	0	79	0	79	0	0	163
5:15:00 PM	58	4	0	62	0	0	7	1	0	8	1	0	1	74	0	75	0	0	145
5:30:00 PM	63	3	0	66	0	0	4	3	0	7	1	0	3	65	0	68	0	0	141
<b>Grand Total</b>	<b>258</b>	<b>21</b>	<b>0</b>	<b>279</b>	<b>2</b>	<b>2</b>	<b>14</b>	<b>7</b>	<b>0</b>	<b>21</b>	<b>2</b>	<b>0</b>	<b>8</b>	<b>297</b>	<b>0</b>	<b>305</b>	<b>0</b>	<b>0</b>	<b>605</b>
% Approach	92.5%	7.5%	0.0%	0.0%	0.0%	0.0%	66.7%	33.3%	0.0%	0.0%	0.0%	0.0%	2.6%	97.4%	0.0%	0.0%	0.0%	0.0%	0.0%
% Total	42.6%	3.5%	0.0%	46.1%	0.0%	0.0%	2.3%	1.2%	0.0%	3.5%	0.0%	0.0%	1.3%	49.1%	0.0%	50.4%	0.0%	0.0%	0.0%
PHF	0.921	0.525	0.000	0.872	0.000	0.000	0.500	0.583	0.000	0.656	0.000	0.000	0.500	0.940	0.000	0.919	0.000	0.000	0.928
Lights	251	20	0	271	0	0	14	7	0	21	0	0	8	292	0	300	0	0	592
% Lights	97.3%	95.2%	0.0%	97.1%	0.0%	0.0%	100.0%	100.0%	0.0%	100.0%	0.0%	0.0%	100.0%	98.3%	0.0%	98.4%	0.0%	0.0%	97.9%
Trucks	1	0	0	1	0	0	0	0	0	0	0	0	0	2	0	2	0	0	3
% Trucks	0.4%	0.0%	0.0%	0.4%	0.0%	0.0%	0.0%	0.0%	0.0%	0.0%	0.0%	0.0%	0.0%	0.7%	0.0%	0.7%	0.0%	0.0%	0.5%
Buses	6	1	0	7	0	0	0	0	0	0	0	0	0	3	0	3	0	0	10
% Buses	2.3%	4.8%	0.0%	0.0%	0.0%	0.0%	0.0%	0.0%	0.0%	0.0%	0.0%	0.0%	0.0%	1.0%	0.0%	0.0%	0.0%	0.0%	1.7%
Pedestrians	0	0	0	0	2	2	0	0	0	2	0	0	0	0	0	0	0	0	0
% Pedestrians	0.0%	0.0%	0.0%	0.0%	100.0%	100.0%	0.0%	0.0%	0.0%	0.0%	100.0%	0.0%	0.0%	0.0%	0.0%	0.0%	0.0%	0.0%	0.0%
Bicycles on Crosswalk	0	0	0	0	0	0	0	0	0	0	0	0	0	0	0	0	0	0	0
% Bicycles on Crosswalk	0.0%	0.0%	0.0%	0.0%	0.0%	0.0%	0.0%	0.0%	0.0%	0.0%	0.0%	0.0%	0.0%	0.0%	0.0%	0.0%	0.0%	0.0%	0.0%

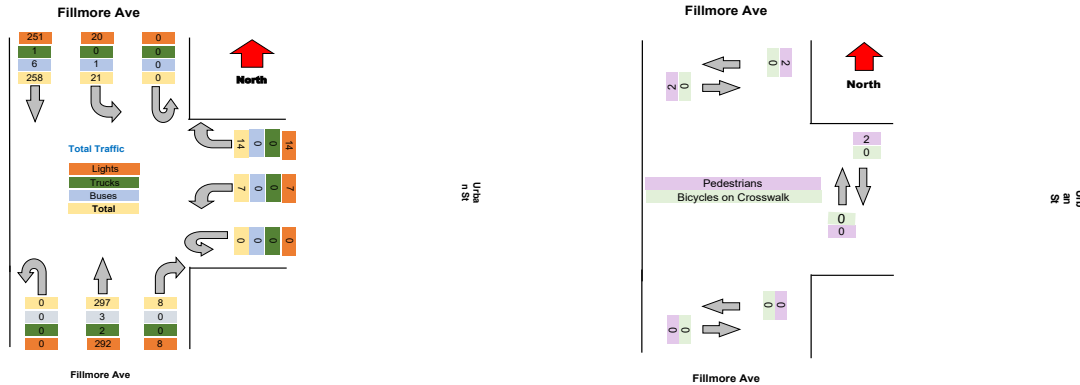

Intersection: Elm St Pine St  
 Location: Kennett Square, PA  
 Site: 01  
 Survey Date: Wednesday, 04-28-2021  
 GPS: 42.948550, -72.790034



Project	LaBella
Project Code	LaBella
Site Name	20
Legs and Movements	All Processed Legs & Movements
Bin Size	15 minutes
Survey Date	2021-11-03, Wednesday
Location	20
Latitude and Longitude	42.909422, -78.839056

	Start	End	PHF
Forced Peak AM	2021/11/03 07:30:00	2021/11/03 08:30:00	0.845
Forced Peak PM	2021/11/03 16:30:00	2021/11/03 17:30:00	0.873
AM Peak	2021/11/03 07:30:00	2021/11/03 08:30:00	0.845
PM Peak	2021/11/03 16:45:00	2021/11/03 17:45:00	0.838

Turning Movement Data

Leg Direction	Fillmore Ave Southbound					Urban St Westbound					Fillmore Ave Northbound					Total
	Thru	Left	U-Turn	App Total	Peds CW Peds CCW	Right	Left	U-Turn	App Total	Peds CW Peds CCW	Right	Thru	U-Turn	App Total	Peds CW Peds CCW	
6:30:00 AM	22	1	0	23	0	3	0	0	3	0	0	18	0	18	0	44
6:45:00 AM	30	1	0	31	0	3	2	0	5	0	0	32	0	33	0	69
<b>Hourly Total</b>	<b>52</b>	<b>2</b>	<b>0</b>	<b>54</b>	<b>0</b>	<b>6</b>	<b>2</b>	<b>0</b>	<b>8</b>	<b>0</b>	<b>0</b>	<b>50</b>	<b>0</b>	<b>51</b>	<b>0</b>	<b>113</b>
7:00:00 AM	34	3	0	37	0	1	0	0	1	4	0	0	26	30	1	68
7:15:00 AM	40	6	0	46	1	2	2	0	4	2	1	0	30	33	0	83
7:30:00 AM	52	9	0	61	0	1	2	0	3	7	3	4	37	51	0	115
7:45:00 AM	80	3	0	83	0	1	1	0	2	10	2	1	62	75	0	160
<b>Hourly Total</b>	<b>206</b>	<b>21</b>	<b>0</b>	<b>227</b>	<b>1</b>	<b>5</b>	<b>5</b>	<b>0</b>	<b>10</b>	<b>23</b>	<b>6</b>	<b>5</b>	<b>155</b>	<b>189</b>	<b>1</b>	<b>426</b>
8:00:00 AM	68	4	0	72	0	8	1	0	9	7	0	1	46	54	0	135
8:15:00 AM	63	5	0	68	0	2	1	0	3	7	0	0	53	60	0	131
<b>Hourly Total</b>	<b>131</b>	<b>9</b>	<b>0</b>	<b>140</b>	<b>0</b>	<b>10</b>	<b>2</b>	<b>0</b>	<b>12</b>	<b>14</b>	<b>0</b>	<b>1</b>	<b>99</b>	<b>114</b>	<b>0</b>	<b>266</b>
4:00:00 PM	66	6	0	72	0	4	2	0	6	4	1	3	80	83	0	161
4:15:00 PM	74	6	0	80	0	5	3	0	8	2	5	5	85	90	0	178
4:30:00 PM	91	8	0	99	0	7	1	0	8	1	2	1	66	67	0	174
4:45:00 PM	84	5	0	89	0	3	3	1	4	2	3	1	101	102	0	195
<b>Hourly Total</b>	<b>315</b>	<b>25</b>	<b>0</b>	<b>340</b>	<b>0</b>	<b>19</b>	<b>7</b>	<b>0</b>	<b>26</b>	<b>9</b>	<b>11</b>	<b>10</b>	<b>332</b>	<b>342</b>	<b>0</b>	<b>708</b>
5:00:00 PM	72	4	0	76	0	4	1	0	5	0	4	2	77	79	0	160
5:15:00 PM	70	4	0	74	0	5	3	0	8	1	1	5	65	70	0	152
5:30:00 PM	74	1	0	75	0	4	3	0	7	0	0	1	64	65	0	147
5:45:00 PM	64	4	0	68	1	6	2	0	8	4	1	1	73	74	1	150
<b>Hourly Total</b>	<b>280</b>	<b>13</b>	<b>0</b>	<b>293</b>	<b>1</b>	<b>19</b>	<b>9</b>	<b>0</b>	<b>28</b>	<b>5</b>	<b>6</b>	<b>9</b>	<b>279</b>	<b>288</b>	<b>1</b>	<b>609</b>
<b>Grand Total</b>	<b>984</b>	<b>70</b>	<b>0</b>	<b>1054</b>	<b>2</b>	<b>59</b>	<b>25</b>	<b>0</b>	<b>84</b>	<b>51</b>	<b>23</b>	<b>26</b>	<b>915</b>	<b>984</b>	<b>2</b>	<b>2122</b>
% Approach	93.4%	6.6%	0.0%	0.0%	0.0%	70.2%	29.8%	0.0%	0.0%	0.0%	0.0%	2.6%	93.0%	0.0%	0.0%	0.0%
% Total	46.4%	3.3%	0.0%	49.7%	0.0%	2.8%	1.2%	0.0%	4.0%	0.0%	0.0%	1.2%	43.1%	0.0%	46.4%	0.0%
Lights	916	66	0	982	0	55	22	0	77	0	0	26	854	880	0	1939
% Lights	93.1%	94.3%	0.0%	93.2%	0.0%	93.2%	88.0%	0.0%	91.7%	0.0%	0.0%	100.0%	93.3%	0.0%	89.4%	0.0%
Trucks	2	0	0	2	0	0	0	0	0	0	0	0	2	2	0	4
% Trucks	0.2%	0.0%	0.0%	0.2%	0.0%	0.0%	0.0%	0.0%	0.0%	0.0%	0.0%	0.0%	0.2%	0.0%	0.2%	0.0%
Buses	66	4	0	70	0	4	3	0	7	0	0	0	59	59	0	136
% Buses	6.7%	5.7%	0.0%	0.0%	0.0%	0.0%	12.0%	0.0%	0.0%	0.0%	0.0%	0.0%	6.4%	0.0%	0.0%	6.4%
Pedestrians	0	0	0	0	2	8	0	0	0	48	20	0	0	0	2	0
% Pedestrians	0.0%	0.0%	0.0%	0.0%	100.0%	88.9%	0.0%	0.0%	0.0%	94.1%	87.0%	0.0%	0.0%	0.0%	100.0%	0.0%
Bicycles on Crosswalk	0	0	0	0	0	1	0	0	0	3	3	0	0	0	0	0
% Bicycles on Crosswalk	0.0%	0.0%	0.0%	0.0%	0.0%	11.1%	0.0%	0.0%	0.0%	5.9%	13.0%	0.0%	0.0%	0.0%	0.0%	0.0%

Turning Movement Data Plot

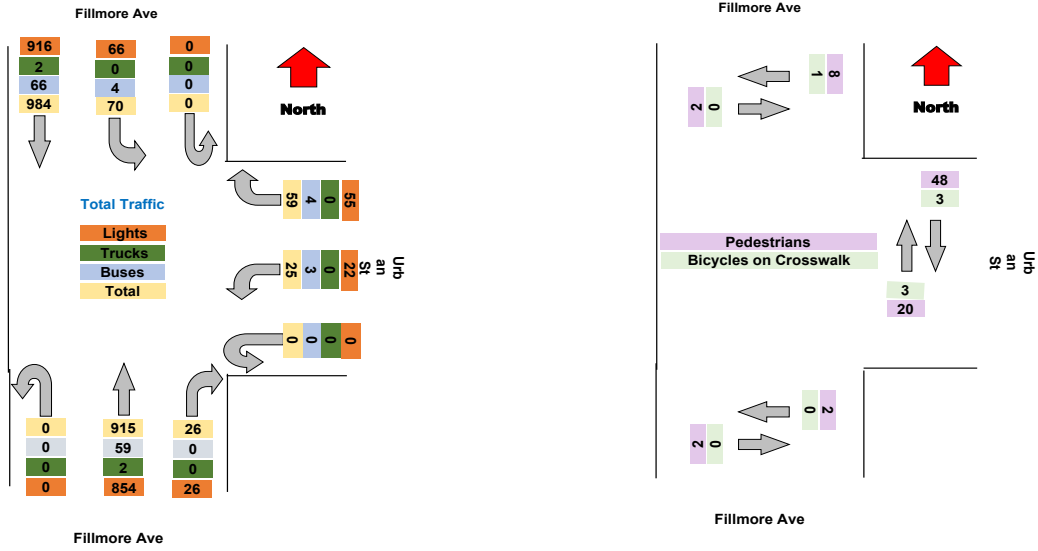

Turning Movement Peak Hour Data (AM)  
 7:30:00 AM

Leg Direction	Fillmore Ave Southbound						Urban St Westbound						Fillmore Ave Northbound						Total
	Thru	Left	U-Turn	App Total	Peds CW	Peds CCW	Right	Left	U-Turn	App Total	Peds CW	Peds CCW	Right	Thru	U-Turn	App Total	Peds CW	Peds CCW	
7:30:00 AM	52	9	0	61	0	0	1	2	0	3	7	3	4	37	0	51	0	0	115
7:45:00 AM	80	3	0	83	0	0	1	1	0	3	10	2	1	62	0	75	0	0	160
8:00:00 AM	68	4	0	72	0	0	8	1	0	9	7	0	1	46	0	54	0	1	135
8:15:00 AM	63	5	0	68	0	0	2	1	0	3	7	0	0	53	0	60	0	0	131
<b>Grand Total</b>	263	21	0	284	0	0	12	5	0	17	31	5	6	198	0	240	0	1	541
% Approach	92.6%	7.4%	0.0%	0.0%	0.0%	0.0%	70.6%	29.4%	0.0%	0.0%	0.0%	0.0%	2.5%	82.5%	0.0%	0.0%	0.0%	0.0%	
% Total	48.6%	3.9%	0.0%	52.5%	0.0%	0.0%	2.2%	0.9%	0.0%	3.1%	0.0%	0.0%	1.1%	36.6%	0.0%	44.4%	0.0%	0.0%	
PHF	0.822	0.583	0.000	0.855	0.000	0.000	0.375	0.625	0.000	0.472	0.000	0.000	0.375	0.798	0.000	0.800	0.000	0.000	0.845
Lights	241	21	0	262	0	0	11	4	0	15	0	0	6	174	0	180	0	0	457
% Lights	91.6%	100.0%	0.0%	92.3%	0.0%	0.0%	91.7%	80.0%	0.0%	88.2%	0.0%	0.0%	100.0%	87.9%	0.0%	75.0%	0.0%	0.0%	84.5%
Trucks	0	0	0	0	0	0	0	0	0	0	0	0	0	0	0	0	0	0	0
% Trucks	0.0%	0.0%	0.0%	0.0%	0.0%	0.0%	0.0%	0.0%	0.0%	0.0%	0.0%	0.0%	0.0%	0.0%	0.0%	0.0%	0.0%	0.0%	0.0%
Buses	22	0	0	22	0	0	1	1	0	2	0	0	0	24	0	24	0	0	48
% Buses	8.4%	0.0%	0.0%	0.0%	0.0%	0.0%	8.3%	20.0%	0.0%	0.0%	0.0%	0.0%	0.0%	12.1%	0.0%	0.0%	0.0%	0.0%	8.9%
Pedestrians	0	0	0	0	0	0	0	0	0	0	30	5	0	0	0	0	0	1	0
% Pedestrians	0.0%	0.0%	0.0%	0.0%	0.0%	0.0%	0.0%	0.0%	0.0%	0.0%	96.8%	100.0%	0.0%	0.0%	0.0%	0.0%	0.0%	100.0%	0.0%
Bicycles on Crosswalk	0	0	0	0	0	0	0	0	0	0	1	0	0	0	0	0	0	0	0
% Bicycles on Crosswalk	0.0%	0.0%	0.0%	0.0%	0.0%	0.0%	0.0%	0.0%	0.0%	0.0%	3.2%	0.0%	0.0%	0.0%	0.0%	0.0%	0.0%	0.0%	0.0%

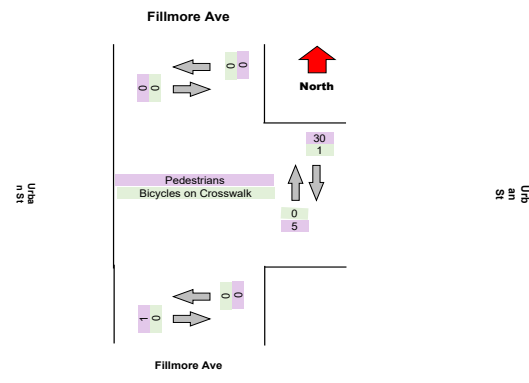
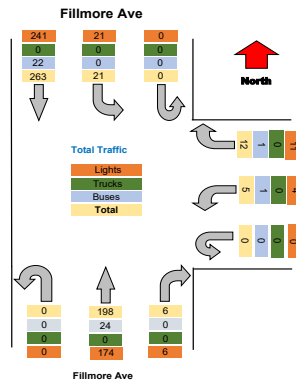

Turning Movement Peak Hour Data (PM)

4:45:00 PM

Leg Direction	Fillmore Ave Southbound						Urban St Westbound						Fillmore Ave Northbound						Total
	Thru	Left	U-Turn	App Total	Peds CW	Peds CCW	Right	Left	U-Turn	App Total	Peds CW	Peds CCW	Right	Thru	U-Turn	App Total	Peds CW	Peds CCW	
4:45:00 PM	84	5	0	89	0	3	3	1	0	4	2	3	1	101	0	102	0	0	195
5:00:00 PM	72	4	0	76	0	1	4	1	0	5	0	4	2	77	0	79	0	0	160
5:15:00 PM	70	4	0	74	0	0	5	3	0	8	1	1	5	65	0	70	0	0	152
5:30:00 PM	74	1	0	75	0	1	4	3	0	7	0	0	1	64	0	65	0	1	147
<b>Grand Total</b>	<b>300</b>	<b>14</b>	<b>0</b>	<b>314</b>	<b>0</b>	<b>5</b>	<b>16</b>	<b>8</b>	<b>0</b>	<b>24</b>	<b>3</b>	<b>8</b>	<b>9</b>	<b>307</b>	<b>0</b>	<b>316</b>	<b>0</b>	<b>1</b>	<b>654</b>
% Approach	95.5%	4.5%	0.0%	0.0%	0.0%	0.0%	66.7%	33.3%	0.0%	0.0%	0.0%	0.0%	2.8%	97.2%	0.0%	0.0%	0.0%	0.0%	
% Total	45.9%	2.1%	0.0%	48.0%	0.0%	0.0%	2.4%	1.2%	0.0%	3.7%	0.0%	0.0%	1.4%	46.9%	0.0%	48.3%	0.0%	0.0%	
PHF	0.893	0.700	0.000	0.882	0.000	0.000	0.800	0.667	0.000	0.750	0.000	0.000	0.450	0.760	0.000	0.775	0.000	0.000	0.838
Lights	292	14	0	306	0	0	15	8	0	23	0	0	9	297	0	306	0	0	635
% Lights	97.3%	100.0%	0.0%	97.5%	0.0%	0.0%	93.8%	#####	0.0%	95.8%	0.0%	0.0%	100.0%	96.7%	0.0%	96.8%	0.0%	0.0%	97.1%
Trucks	0	0	0	0	0	0	0	0	0	0	0	0	0	1	0	1	0	0	1
% Trucks	0.0%	0.0%	0.0%	0.0%	0.0%	0.0%	0.0%	0.0%	0.0%	0.0%	0.0%	0.0%	0.0%	0.3%	0.0%	0.3%	0.0%	0.0%	0.2%
Buses	8	0	0	8	0	0	1	0	0	1	0	0	0	0	0	9	0	0	18
% Buses	2.7%	0.0%	0.0%	0.0%	0.0%	0.0%	6.3%	0.0%	0.0%	0.0%	0.0%	0.0%	0.0%	2.9%	0.0%	0.0%	0.0%	0.0%	2.8%
Pedestrians	0	0	0	0	0	4	0	0	0	3	6	0	0	0	0	0	0	1	0
% Pedestrians	0.0%	0.0%	0.0%	0.0%	0.0%	80.0%	0.0%	0.0%	0.0%	0.0%	100.0%	75.0%	0.0%	0.0%	0.0%	0.0%	0.0%	100.0%	0.0%
Bicycles on Crosswalk	0	0	0	0	0	1	0	0	0	0	2	0	0	0	0	0	0	0	0
% Bicycles on Crosswalk	0.0%	0.0%	0.0%	0.0%	0.0%	20.0%	0.0%	0.0%	0.0%	0.0%	25.0%	0.0%	0.0%	0.0%	0.0%	0.0%	0.0%	0.0%	0.0%

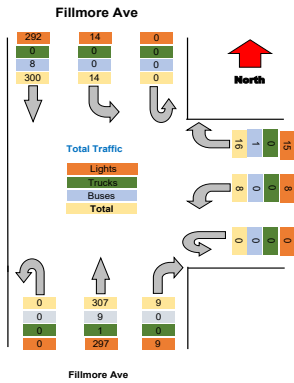

Urban St

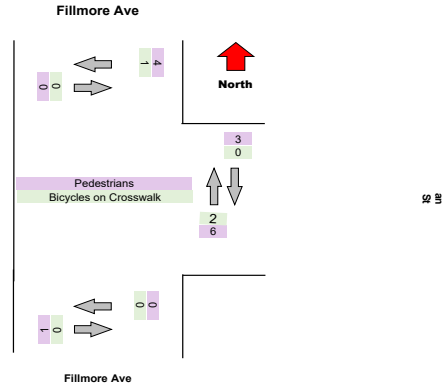





Turning Movement Data Plot

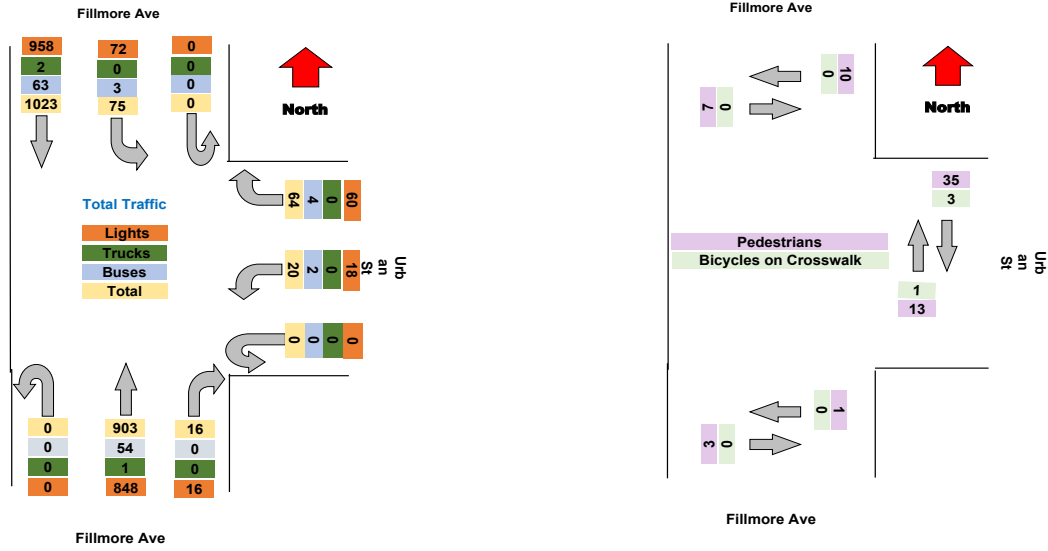



**Turning Movement Peak Hour Data (PM)**  
 4:45:00 PM

Leg Direction	Fillmore Ave Southbound						Urban St Westbound						Fillmore Ave Northbound						Total
	Thru	Left	U-Turn	App Total	Peds CW	Peds CCW	Right	Left	U-Turn	App Total	Peds CW	Peds CCW	Right	Thru	U-Turn	App Total	Peds CW	Peds CCW	
4:45:00 PM	90	4	0	94	0	4	8	3	0	11	0	4	2	94	0	96	0	0	201
5:00:00 PM	71	4	0	75	1	1	7	3	0	10	2	0	1	91	0	92	0	0	177
5:15:00 PM	80	3	0	83	1	1	5	1	0	6	0	0	1	79	0	80	0	0	169
5:30:00 PM	73	5	0	78	0	1	4	1	0	5	2	0	0	65	0	65	0	0	148
<b>Grand Total</b>	<b>314</b>	<b>16</b>	<b>0</b>	<b>330</b>	<b>2</b>	<b>7</b>	<b>24</b>	<b>8</b>	<b>0</b>	<b>32</b>	<b>4</b>	<b>4</b>	<b>4</b>	<b>329</b>	<b>0</b>	<b>333</b>	<b>0</b>	<b>0</b>	<b>695</b>
% Approach	95.2%	4.8%	0.0%	0.0%	0.0%	0.0%	75.0%	25.0%	0.0%	0.0%	0.0%	0.0%	1.2%	98.8%	0.0%	0.0%	0.0%	0.0%	0.0%
% Total	45.2%	2.3%	0.0%	47.5%	0.0%	0.0%	3.5%	1.2%	0.0%	4.6%	0.0%	0.0%	0.6%	47.3%	0.0%	47.9%	0.0%	0.0%	0.0%
PHF	0.872	0.800	0.000	0.878	0.000	0.000	0.750	0.667	0.000	0.727	0.000	0.000	0.500	0.875	0.000	0.867	0.000	0.000	0.864
Lights	302	16	0	318	0	0	24	8	0	32	0	0	4	320	0	324	0	0	674
% Lights	96.2%	100.0%	0.0%	96.4%	0.0%	0.0%	100.0%	100.0%	0.0%	100.0%	0.0%	0.0%	100.0%	97.3%	0.0%	97.3%	0.0%	0.0%	97.0%
Trucks	2	0	0	2	0	0	0	0	0	0	0	0	0	1	0	1	0	0	3
% Trucks	0.6%	0.0%	0.0%	0.6%	0.0%	0.0%	0.0%	0.0%	0.0%	0.0%	0.0%	0.0%	0.0%	0.3%	0.0%	0.3%	0.0%	0.0%	0.4%
Buses	10	0	0	10	0	0	0	0	0	0	0	0	0	8	0	8	0	0	18
% Buses	3.2%	0.0%	0.0%	0.0%	0.0%	0.0%	0.0%	0.0%	0.0%	0.0%	0.0%	0.0%	0.0%	2.4%	0.0%	0.0%	0.0%	0.0%	2.6%
Pedestrians	0	0	0	0	2	7	0	0	0	2	4	0	0	0	0	0	0	0	0
% Pedestrians	0.0%	0.0%	0.0%	0.0%	100.0%	100.0%	0.0%	0.0%	0.0%	0.0%	50.0%	100.0%	0.0%	0.0%	0.0%	0.0%	0.0%	0.0%	0.0%
Bicycles on Crosswalk	0	0	0	0	0	0	0	0	0	2	0	0	0	0	0	0	0	0	0
% Bicycles on Crosswalk	0.0%	0.0%	0.0%	0.0%	0.0%	0.0%	0.0%	0.0%	0.0%	0.0%	50.0%	0.0%	0.0%	0.0%	0.0%	0.0%	0.0%	0.0%	0.0%

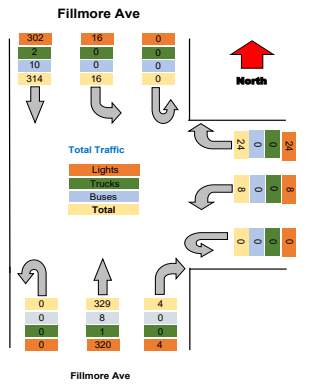

Urban St

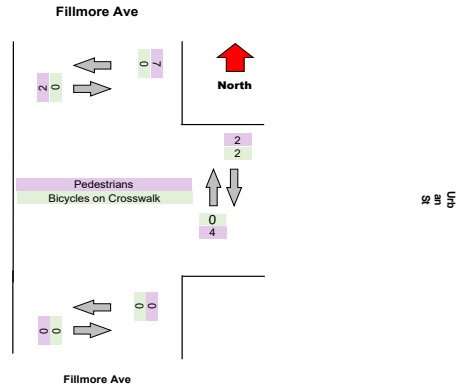

Urban St



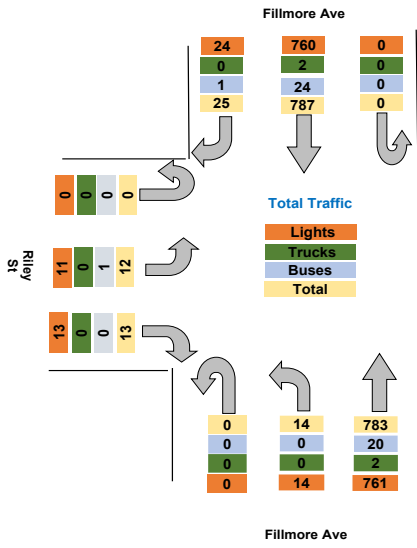

Turning Movement Data Plot

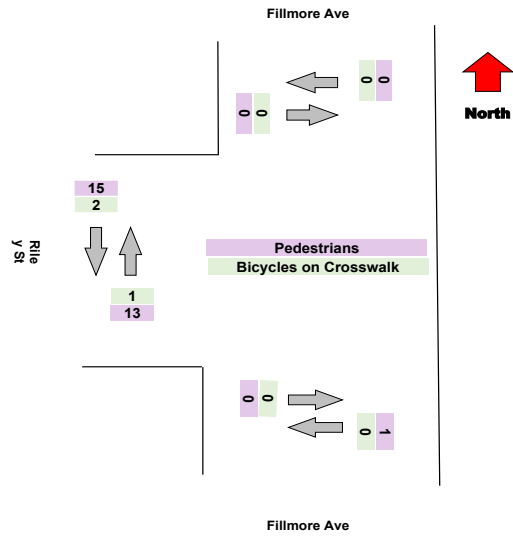

Turning Movement Peak Hour Data (AM)

7:30:00 AM

Leg Direction	Fillmore Ave Southbound						Fillmore Ave NorthBound						Riley St Eastbound				
	Right	Thru	U-Turn	App Total	Peds CW	Peds CCW	Thru	Left	U-Turn	App Total	Peds CW	Peds CCW	Right	Left	U-Turn	App Total	Peds CW
7:30:00 AM	0	27	0	27	0	0	27	0	0	27	0	0	0	2	0	2	1
7:45:00 AM	0	43	0	43	0	0	37	0	0	37	0	0	0	1	0	1	0
8:00:00 AM	1	46	0	47	0	0	29	0	0	29	0	0	0	0	0	0	0
8:15:00 AM	1	45	0	46	0	0	28	1	0	29	0	0	0	1	0	1	0
<b>Grand Total</b>	<b>2</b>	<b>161</b>	<b>0</b>	<b>163</b>	<b>0</b>	<b>0</b>	<b>121</b>	<b>1</b>	<b>0</b>	<b>122</b>	<b>0</b>	<b>0</b>	<b>0</b>	<b>4</b>	<b>0</b>	<b>4</b>	<b>1</b>
% Approach	1.2%	98.8%	0.0%	0.0%	0.0%	0.0%	99.2%	0.8%	0.0%	0.0%	0.0%	0.0%	0.0%	100.0%	0.0%	0.0%	0.0%
% Total	0.7%	55.7%	0.0%	56.4%	0.0%	0.0%	41.9%	0.3%	0.0%	42.2%	0.0%	0.0%	0.0%	1.4%	0.0%	1.4%	0.0%
PHF	0.500	0.875	0.000	0.867	0.000	0.000	0.818	0.250	0.000	0.824	0.000	0.000	0.000	0.500	0.000	0.500	0.000
Lights	2	154	0	156	0	0	112	1	0	113	0	0	0	4	0	4	0
% Lights	100.0%	95.7%	0.0%	95.7%	0.0%	0.0%	92.6%	100.0%	0.0%	92.6%	0.0%	0.0%	0.0%	100.0%	0.0%	100.0%	0.0%
Trucks	0	0	0	0	0	0	0	0	0	0	0	0	0	0	0	0	0
% Trucks	0.0%	0.0%	0.0%	0.0%	0.0%	0.0%	0.0%	0.0%	0.0%	0.0%	0.0%	0.0%	0.0%	0.0%	0.0%	0.0%	0.0%
Buses	0	7	0	7	0	0	9	0	0	9	0	0	0	0	0	0	0
% Buses	0.0%	4.3%	0.0%	0.0%	0.0%	0.0%	7.4%	0.0%	0.0%	0.0%	0.0%	0.0%	0.0%	0.0%	0.0%	0.0%	0.0%
Pedestrians	0	0	0	0	0	0	0	0	0	0	0	0	0	0	0	0	1
% Pedestrians	0.0%	0.0%	0.0%	0.0%	0.0%	0.0%	0.0%	0.0%	0.0%	0.0%	0.0%	0.0%	0.0%	0.0%	0.0%	0.0%	100.0%
Bicycles on Crosswalk	0	0	0	0	0	0	0	0	0	0	0	0	0	0	0	0	0
% Bicycles on Crosswalk	0.0%	0.0%	0.0%	0.0%	0.0%	0.0%	0.0%	0.0%	0.0%	0.0%	0.0%	0.0%	0.0%	0.0%	0.0%	0.0%	0.0%

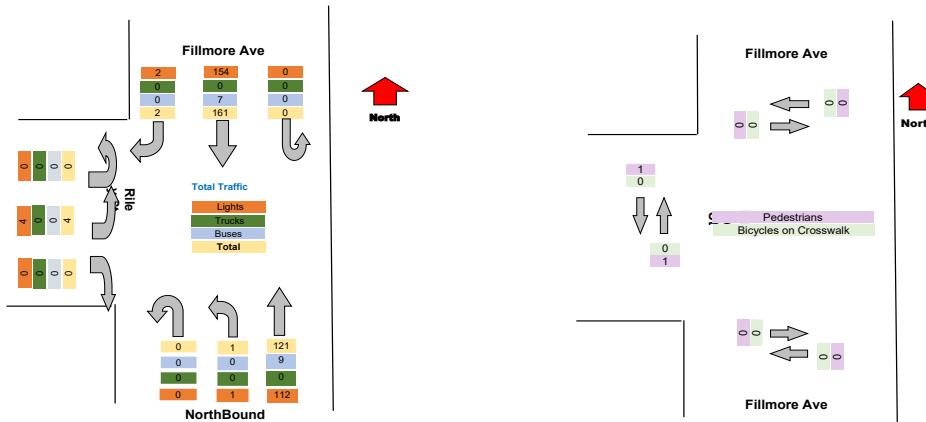

Turning Movement Peak Hour Data (PM)

4:45:00 PM

Leg Direction	Fillmore Ave Southbound						Fillmore Ave NorthBound						Riley St Eastbound				
	Right	Thru	U-Turn	App Total	Peds CW	Peds CCW	Thru	Left	U-Turn	App Total	Peds CW	Peds CCW	Right	Left	U-Turn	App Total	Peds CW
4:45:00 PM	3	65	0	68	0	0	81	1	0	82	0	0	2	2	0	4	2
5:00:00 PM	3	69	0	72	0	0	78	1	0	79	0	0	4	1	0	5	3
5:15:00 PM	1	56	0	57	0	0	75	1	0	76	0	0	2	0	0	2	2
5:30:00 PM	1	69	0	70	0	0	66	2	0	68	0	0	1	2	0	3	0
<b>Grand Total</b>	<b>8</b>	<b>259</b>	<b>0</b>	<b>267</b>	<b>0</b>	<b>0</b>	<b>300</b>	<b>5</b>	<b>0</b>	<b>305</b>	<b>0</b>	<b>0</b>	<b>9</b>	<b>5</b>	<b>0</b>	<b>14</b>	<b>7</b>
% Approach	3.0%	97.0%	0.0%	0.0%	0.0%	0.0%	98.4%	1.6%	0.0%	0.0%	0.0%	0.0%	64.3%	35.7%	0.0%	0.0%	0.0%
% Total	1.4%	44.2%	0.0%	45.6%	0.0%	0.0%	51.2%	0.9%	0.0%	52.0%	0.0%	0.0%	1.5%	0.9%	0.0%	2.4%	0.0%
PHF	0.667	0.938	0.000	0.927	0.000	0.000	0.926	0.625	0.000	0.930	0.000	0.000	0.563	0.625	0.000	0.700	0.000
Lights	8	252	0	260	0	0	295	5	0	300	0	0	9	5	0	14	0
% Lights	100.0%	97.3%	0.0%	97.4%	0.0%	0.0%	98.3%	100.0%	0.0%	98.4%	0.0%	0.0%	100.0%	100.0%	0.0%	100.0%	0.0%
Trucks	0	1	0	1	0	0	2	0	0	2	0	0	0	0	0	0	0
% Trucks	0.0%	0.4%	0.0%	0.4%	0.0%	0.0%	0.7%	0.0%	0.0%	0.7%	0.0%	0.0%	0.0%	0.0%	0.0%	0.0%	0.0%
Buses	0	6	0	6	0	0	3	0	0	3	0	0	0	0	0	0	0
% Buses	0.0%	2.3%	0.0%	0.0%	0.0%	0.0%	1.0%	0.0%	0.0%	0.0%	0.0%	0.0%	0.0%	0.0%	0.0%	0.0%	0.0%
Pedestrians	0	0	0	0	0	0	0	0	0	0	0	0	0	0	0	0	6
% Pedestrians	0.0%	0.0%	0.0%	0.0%	0.0%	0.0%	0.0%	0.0%	0.0%	0.0%	0.0%	0.0%	0.0%	0.0%	0.0%	0.0%	85.7%
Bicycles on Crosswalk	0	0	0	0	0	0	0	0	0	0	0	0	0	0	0	0	1
% Bicycles on Crosswalk	0.0%	0.0%	0.0%	0.0%	0.0%	0.0%	0.0%	0.0%	0.0%	0.0%	0.0%	0.0%	0.0%	0.0%	0.0%	0.0%	14.3%

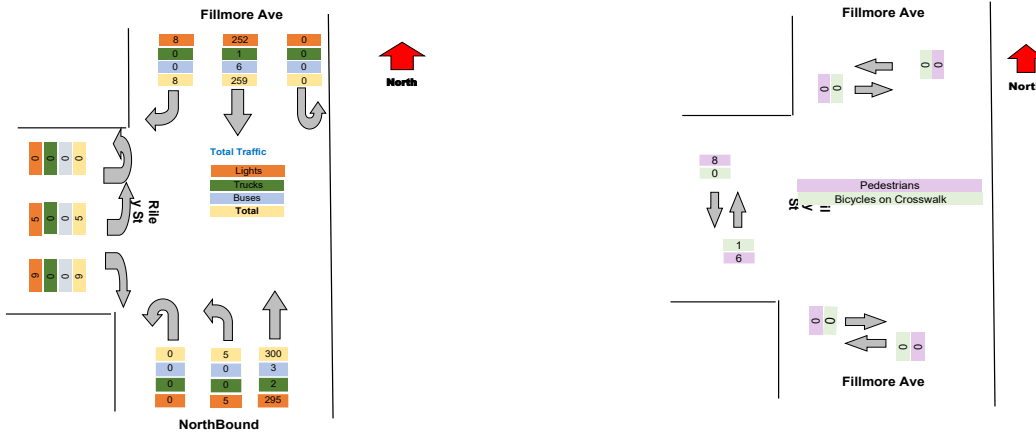



Intersection: Elm St Pine St  
 Location: Kennett Square, PA  
 Site: 01  
 Survey Date: Wednesday, 04-28-2021  
 GPS: 42.948550, -72.790034



Peds CCW	Total
1	39
1	53
2	92
0	50
0	58
0	56
0	81
0	245
1	76
0	76
1	152
0	161
2	149
1	132
4	154
7	596
0	156
4	135
0	141
3	117
7	549
17	1634
0.0%	0.0%
0.0%	0.0%
0	1583
0.0%	96.9%
0	4
0.0%	0.2%
0	46
0.0%	2.8%
15	0
88.2%	0.0%
2	0
11.8%	0.0%

Intersection: Elm St Pine St  
 Location: Kennett Square, PA  
 Site: 01  
 Survey Date: Wednesday, 04-28-2021  
 GPS: 42.948550, -72.790034



Peds CCW	Total
0	56
0	81
1	76
0	76
1	289
0.0%	
0.0%	
0.000	0.892
0	273
0.0%	94.5%
0	0
0.0%	0.0%
0	16
0.0%	5.5%
1	0
100.0%	0.0%
0	0
0.0%	0.0%

Intersection: Elm St Pine St  
 Location: Kennett Square, PA  
 Site: 01  
 Survey Date: Wednesday, 04-28-2021  
 GPS: 42.948550, -72.790034



Peds CCW	Total
4	154
0	156
4	135
0	141
8	586
0.0%	
0.0%	
0.000	0.939
0	574
0.0%	98.0%
0	3
0.0%	0.5%
0	9
0.0%	1.5%
8	0
100.0%	0.0%
0	0
0.0%	0.0%

Project	LaBella
Project Code	LaBella
Site Name	21
Legs and Movements	All Processed Legs & Movements
Bin Size	15 minutes
Survey Date	2021-11-03, Wednesday
Location	21
Latitude and Longitude	42.909289, -78.839090

	Start	End	PHF
Forced Peak AM	2021/11/03 07:30:00	2021/11/03 08:30:00	0.818
Forced Peak PM	2021/11/03 16:30:00	2021/11/03 17:30:00	0.861
AM Peak	2021/11/03 07:30:00	2021/11/03 08:30:00	0.818
PM Peak	2021/11/03 16:45:00	2021/11/03 17:45:00	0.833

Turning Movement Data

Leg Direction	Fillmore Ave Southbound					Fillmore Ave Northbound					Riley St Eastbound				
	Right	Thru	U-Turn	App Total	Peds CW Peds CCW	Thru	Left	U-Turn	App Total	Peds CW Peds CCW	Right	Left	U-Turn	App Total	Peds CW
Start Time															
6:30:00 AM	1	21	0	22	0 0	18	0	0	18	0 0	1	0	0	1	0
6:45:00 AM	3	29	0	32	0 0	33	0	0	33	0 0	0	0	0	0	0
<b>Hourly Total</b>	<b>4</b>	<b>50</b>	<b>0</b>	<b>54</b>	<b>0 0</b>	<b>51</b>	<b>0</b>	<b>0</b>	<b>51</b>	<b>0 0</b>	<b>1</b>	<b>0</b>	<b>0</b>	<b>1</b>	<b>0</b>
7:00:00 AM	0	34	0	34	0 0	26	0	0	26	0 0	0	0	0	0	0
7:15:00 AM	1	41	0	42	0 0	30	0	0	30	0 0	0	0	0	0	0
7:30:00 AM	1	52	0	53	0 0	37	2	0	39	0 0	0	4	0	4	0
7:45:00 AM	1	81	0	82	0 0	62	1	0	63	0 0	1	1	0	2	0
<b>Hourly Total</b>	<b>3</b>	<b>208</b>	<b>0</b>	<b>211</b>	<b>0 0</b>	<b>155</b>	<b>3</b>	<b>0</b>	<b>158</b>	<b>0 0</b>	<b>1</b>	<b>5</b>	<b>0</b>	<b>6</b>	<b>1</b>
8:00:00 AM	1	68	0	69	0 0	47	1	0	48	0 0	2	0	0	2	0
8:15:00 AM	0	64	0	64	0 0	53	1	0	54	0 0	1	0	0	1	1
<b>Hourly Total</b>	<b>1</b>	<b>132</b>	<b>0</b>	<b>133</b>	<b>0 0</b>	<b>100</b>	<b>2</b>	<b>0</b>	<b>102</b>	<b>0 0</b>	<b>3</b>	<b>0</b>	<b>0</b>	<b>3</b>	<b>1</b>
4:00:00 PM	1	67	0	68	0 0	81	0	0	81	1 1	1	3	0	4	3
4:15:00 PM	4	73	0	77	0 0	88	0	0	88	0 0	0	1	0	1	1
4:30:00 PM	4	87	0	91	0 0	67	3	0	70	0 0	2	0	0	2	0
4:45:00 PM	2	84	0	86	0 1	101	0	0	101	0 0	1	1	0	2	4
<b>Hourly Total</b>	<b>11</b>	<b>311</b>	<b>0</b>	<b>322</b>	<b>0 1</b>	<b>337</b>	<b>3</b>	<b>0</b>	<b>340</b>	<b>1 1</b>	<b>4</b>	<b>5</b>	<b>0</b>	<b>9</b>	<b>8</b>
5:00:00 PM	1	72	0	73	0 0	77	1	0	78	0 0	0	2	0	2	1
5:15:00 PM	3	70	0	73	0 0	68	2	0	70	0 0	1	2	0	3	5
5:30:00 PM	3	74	0	77	1 0	64	1	0	65	0 0	0	0	0	0	4
5:45:00 PM	2	64	0	66	0 1	74	3	0	77	3 0	2	1	0	3	5
<b>Hourly Total</b>	<b>9</b>	<b>280</b>	<b>0</b>	<b>289</b>	<b>1 1</b>	<b>283</b>	<b>7</b>	<b>0</b>	<b>290</b>	<b>3 0</b>	<b>3</b>	<b>5</b>	<b>0</b>	<b>8</b>	<b>15</b>
<b>Grand Total</b>	<b>28</b>	<b>981</b>	<b>0</b>	<b>1009</b>	<b>1 2</b>	<b>926</b>	<b>15</b>	<b>0</b>	<b>941</b>	<b>4 1</b>	<b>12</b>	<b>15</b>	<b>0</b>	<b>27</b>	<b>25</b>
% Approach	2.8%	97.2%	0.0%	0.0%	0.0%	98.4%	1.6%	0.0%	0.0%	0.0%	44.4%	55.6%	0.0%	0.0%	0.0%
% Total	1.4%	49.6%	0.0%	51.0%	0.0%	46.8%	0.8%	0.0%	47.6%	0.0%	0.6%	0.8%	0.0%	1.4%	0.0%
Lights	24	914	0	938	0 0	867	13	0	880	0 0	10	13	0	23	0
% Lights	85.7%	93.2%	0.0%	93.0%	0.0%	93.6%	86.7%	0.0%	93.5%	0.0%	83.3%	86.7%	0.0%	85.2%	0.0%
Trucks	0	2	0	2	0 0	2	0	0	2	0 0	0	0	0	0	0
% Trucks	0.0%	0.2%	0.0%	0.2%	0.0%	0.2%	0.0%	0.0%	0.2%	0.0%	0.0%	0.0%	0.0%	0.0%	0.0%
Buses	4	65	0	69	0 0	57	2	0	59	0 0	2	2	0	4	0
% Buses	14.3%	6.6%	0.0%	0.0%	0.0%	0.0%	13.3%	0.0%	0.0%	0.0%	16.7%	13.3%	0.0%	0.0%	0.0%
Pedestrians	0	0	0	0	1 2	0	0	0	0	3 0	0	0	0	0	23
% Pedestrians	0.0%	0.0%	0.0%	0.0%	100.0%	0.0%	0.0%	0.0%	0.0%	75.0%	0.0%	0.0%	0.0%	0.0%	92.0%
Bicycles on Crosswalk	0	0	0	0	0 0	0	0	0	0	1 1	0	0	0	0	2
% Bicycles on Crosswalk	0.0%	0.0%	0.0%	0.0%	0.0%	0.0%	0.0%	0.0%	0.0%	25.0%	100.0%	0.0%	0.0%	0.0%	8.0%

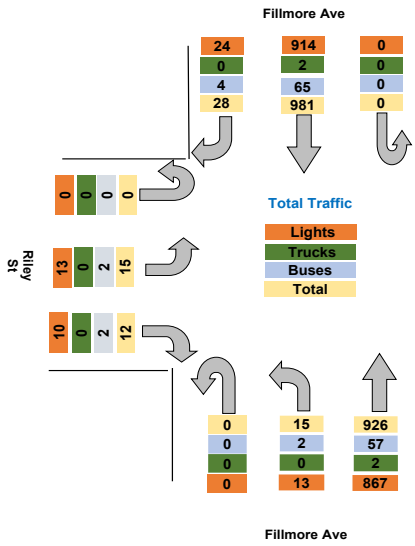

Turning Movement Data Plot

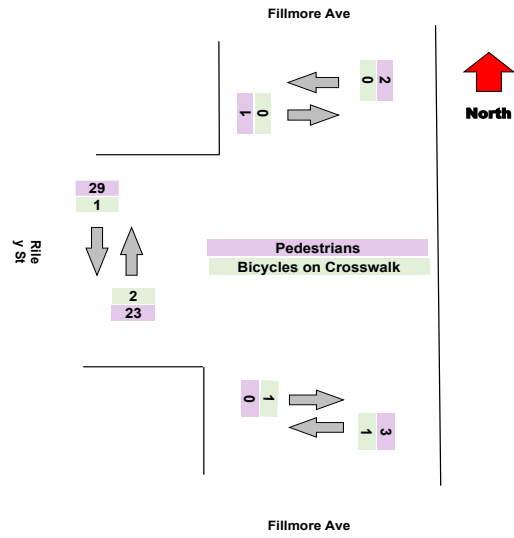

Turning Movement Peak Hour Data (AM)

7:30:00 AM

Leg Direction	Fillmore Ave Southbound						Fillmore Ave NorthBound						Riley St Eastbound				
	Right	Thru	U-Turn	App Total	Peds CW	Peds CCW	Thru	Left	U-Turn	App Total	Peds CW	Peds CCW	Right	Left	U-Turn	App Total	Peds CW
7:30:00 AM	1	52	0	53	0	0	37	2	0	39	0	0	0	4	0	4	0
7:45:00 AM	1	81	0	82	0	0	62	1	0	63	0	0	1	1	0	2	0
8:00:00 AM	1	68	0	69	0	0	47	1	0	48	0	0	2	0	0	2	0
8:15:00 AM	0	64	0	64	0	0	53	1	0	54	0	0	1	0	0	1	1
<b>Grand Total</b>	<b>3</b>	<b>265</b>	<b>0</b>	<b>268</b>	<b>0</b>	<b>0</b>	<b>199</b>	<b>5</b>	<b>0</b>	<b>204</b>	<b>0</b>	<b>0</b>	<b>4</b>	<b>5</b>	<b>0</b>	<b>9</b>	<b>1</b>
% Approach	1.1%	98.9%	0.0%	0.0%	0.0%	0.0%	97.5%	2.5%	0.0%	0.0%	0.0%	0.0%	44.4%	55.6%	0.0%	0.0%	0.0%
% Total	0.6%	55.1%	0.0%	55.7%	0.0%	0.0%	41.4%	1.0%	0.0%	42.4%	0.0%	0.0%	0.8%	1.0%	0.0%	1.9%	0.0%
PHF	0.750	0.818	0.000	0.817	0.000	0.000	0.802	0.625	0.000	0.810	0.000	0.000	0.500	0.313	0.000	0.563	0.000
Lights	3	242	0	245	0	0	176	4	0	180	0	0	3	4	0	7	0
% Lights	100.0%	91.3%	0.0%	91.4%	0.0%	0.0%	88.4%	80.0%	0.0%	88.2%	0.0%	0.0%	75.0%	80.0%	0.0%	77.8%	0.0%
Trucks	0	0	0	0	0	0	0	0	0	0	0	0	0	0	0	0	0
% Trucks	0.0%	0.0%	0.0%	0.0%	0.0%	0.0%	0.0%	0.0%	0.0%	0.0%	0.0%	0.0%	0.0%	0.0%	0.0%	0.0%	0.0%
Buses	0	23	0	23	0	0	23	1	0	24	0	0	1	1	0	2	0
% Buses	0.0%	8.7%	0.0%	0.0%	0.0%	0.0%	11.6%	20.0%	0.0%	0.0%	0.0%	0.0%	25.0%	20.0%	0.0%	0.0%	0.0%
Pedestrians	0	0	0	0	0	0	0	0	0	0	0	0	0	0	0	0	1
% Pedestrians	0.0%	0.0%	0.0%	0.0%	0.0%	0.0%	0.0%	0.0%	0.0%	0.0%	0.0%	0.0%	0.0%	0.0%	0.0%	0.0%	100.0%
Bicycles on Crosswalk	0	0	0	0	0	0	0	0	0	0	0	0	0	0	0	0	0
% Bicycles on Crosswalk	0.0%	0.0%	0.0%	0.0%	0.0%	0.0%	0.0%	0.0%	0.0%	0.0%	0.0%	0.0%	0.0%	0.0%	0.0%	0.0%	0.0%

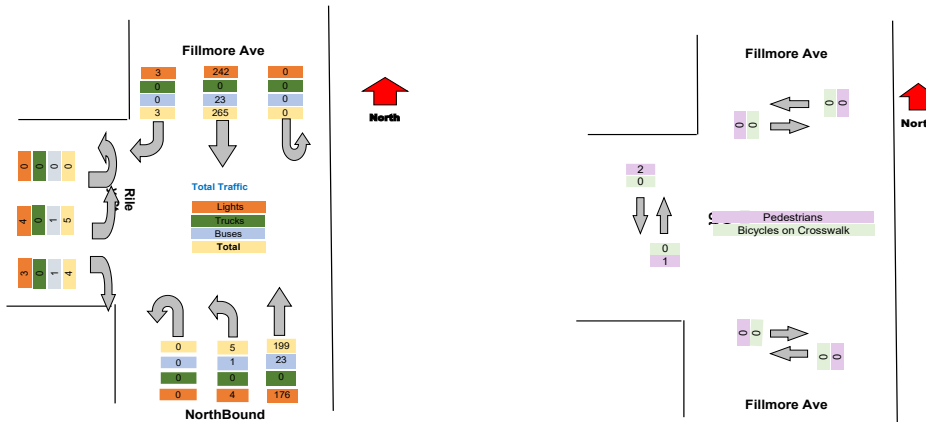

Turning Movement Peak Hour Data (PM)

4:45:00 PM

Leg Direction	Fillmore Ave Southbound						Fillmore Ave NorthBound						Riley St Eastbound				
	Right	Thru	U-Turn	App Total	Peds CW	Peds CCW	Thru	Left	U-Turn	App Total	Peds CW	Peds CCW	Right	Left	U-Turn	App Total	Peds CW
4:45:00 PM	2	84	0	86	0	1	101	0	0	101	0	0	1	1	0	2	4
5:00:00 PM	1	72	0	73	0	0	77	1	0	78	0	0	0	2	0	2	1
5:15:00 PM	3	70	0	73	0	0	68	2	0	70	0	0	1	2	0	3	5
5:30:00 PM	3	74	0	77	1	0	64	1	0	65	0	0	0	0	0	0	4
<b>Grand Total</b>	<b>9</b>	<b>300</b>	<b>0</b>	<b>309</b>	<b>1</b>	<b>1</b>	<b>310</b>	<b>4</b>	<b>0</b>	<b>314</b>	<b>0</b>	<b>0</b>	<b>2</b>	<b>5</b>	<b>0</b>	<b>7</b>	<b>14</b>
% Approach	2.9%	97.1%	0.0%	0.0%	0.0%	0.0%	98.7%	1.3%	0.0%	0.0%	0.0%	0.0%	28.6%	71.4%	0.0%	0.0%	0.0%
% Total	1.4%	47.6%	0.0%	49.0%	0.0%	0.0%	49.2%	0.6%	0.0%	49.8%	0.0%	0.0%	0.3%	0.8%	0.0%	1.1%	0.0%
PHF	0.750	0.893	0.000	0.898	0.000	0.000	0.767	0.500	0.000	0.777	0.000	0.000	0.500	0.625	0.000	0.583	0.000
Lights	8	292	0	300	0	0	301	3	0	304	0	0	2	5	0	7	0
% Lights	88.9%	97.3%	0.0%	97.1%	0.0%	0.0%	97.1%	75.0%	0.0%	96.8%	0.0%	0.0%	100.0%	100.0%	0.0%	100.0%	0.0%
Trucks	0	0	0	0	0	0	1	0	0	1	0	0	0	0	0	0	0
% Trucks	0.0%	0.0%	0.0%	0.0%	0.0%	0.0%	0.3%	0.0%	0.0%	0.3%	0.0%	0.0%	0.0%	0.0%	0.0%	0.0%	0.0%
Buses	1	8	0	9	0	0	2	1	0	3	0	0	0	0	0	0	0
% Buses	11.1%	2.7%	0.0%	0.0%	0.0%	0.0%	2.6%	25.0%	0.0%	0.0%	0.0%	0.0%	0.0%	0.0%	0.0%	0.0%	0.0%
Pedestrians	0	0	0	0	1	1	0	0	0	0	0	0	0	0	0	0	13
% Pedestrians	0.0%	0.0%	0.0%	0.0%	100.0%	100.0%	0.0%	0.0%	0.0%	0.0%	0.0%	0.0%	0.0%	0.0%	0.0%	0.0%	92.9%
Bicycles on Crosswalk	0	0	0	0	0	0	0	0	0	0	0	0	0	0	0	0	1
% Bicycles on Crosswalk	0.0%	0.0%	0.0%	0.0%	0.0%	0.0%	0.0%	0.0%	0.0%	0.0%	0.0%	0.0%	0.0%	0.0%	0.0%	0.0%	7.1%

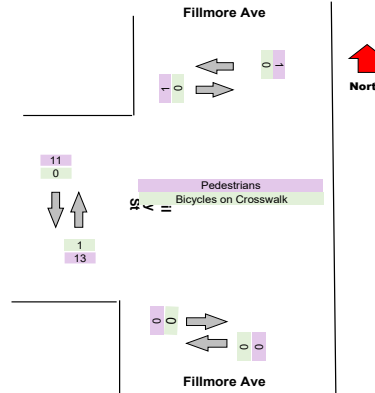
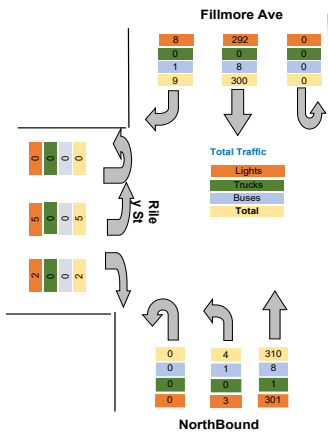

Intersection: Elm St Pine St  
 Location: Kennett Square, PA  
 Site: 01  
 Survey Date: Wednesday, 04-28-2021  
 GPS: 42.948550, -72.790034

Peds CCW	Total
1	41
0	65
1	106
0	60
2	72
1	96
1	147
4	375
0	119
0	119
0	238
1	153
2	166
6	163
2	189
11	671
6	153
0	146
3	142
5	146
14	587
30	1977
0.0%	0.0%
0.0%	0.0%
0	1841
0.0%	93.1%
0	4
0.0%	0.2%
0	132
0.0%	6.7%
29	0
96.7%	0.0%
1	0
3.3%	0.0%



Intersection: Elm St Pine St  
 Location: Kennett Square, PA  
 Site: 01  
 Survey Date: Wednesday, 04-28-2021  
 GPS: 42.948550, -72.790034



Peds CCW	Total
1	96
1	147
0	119
0	119
2	481
0.0%	
0.0%	
0.000	0.818
0	432
0.0%	89.8%
0	0
0.0%	0.0%
0	49
0.0%	10.2%
2	0
100.0%	0.0%
0	0
0.0%	0.0%

Intersection: Elm St Pine St  
 Location: Kennett Square, PA  
 Site: 01  
 Survey Date: Wednesday, 04-28-2021  
 GPS: 42.948550, -72.790034



Peds CCW	Total
2	189
6	153
0	146
3	142
11	630
0.0%	
0.0%	
0.000	0.833
0	611
0.0%	97.0%
0	1
0.0%	0.2%
0	18
0.0%	2.9%
11	0
100.0%	0.0%
0	0
0.0%	0.0%



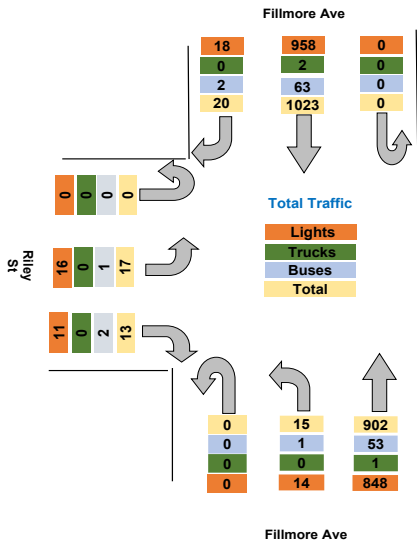

Turning Movement Data Plot

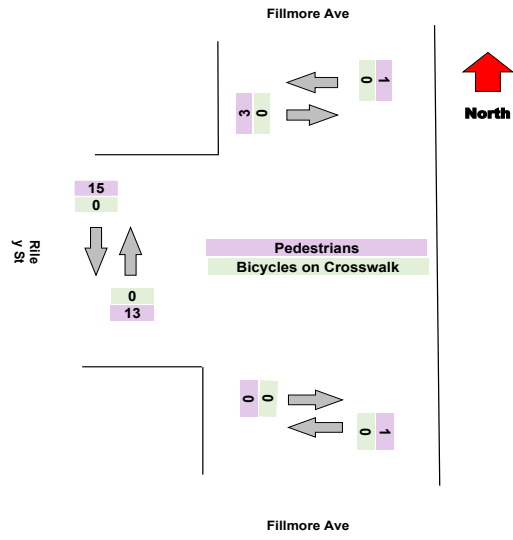

Turning Movement Peak Hour Data (AM)

7:30:00 AM

Leg Direction	Fillmore Ave Southbound						Fillmore Ave NorthBound						Riley St Eastbound				
	Right	Thru	U-Turn	App Total	Peds CW	Peds CCW	Thru	Left	U-Turn	App Total	Peds CW	Peds CCW	Right	Left	U-Turn	App Total	Peds CW
7:30:00 AM	0	62	0	62	0	0	34	1	0	35	0	0	0	1	0	1	1
7:45:00 AM	0	71	0	71	1	0	45	0	0	45	0	0	0	1	0	1	0
8:00:00 AM	0	83	0	83	0	0	53	0	0	53	0	0	1	0	0	1	0
8:15:00 AM	0	73	0	73	2	0	51	1	0	52	0	0	1	3	0	4	0
<b>Grand Total</b>	0	289	0	289	3	0	183	2	0	185	0	0	2	5	0	7	1
% Approach	0.0%	100.0%	0.0%	0.0%	0.0%	0.0%	98.9%	1.1%	0.0%	0.0%	0.0%	0.0%	28.6%	71.4%	0.0%	0.0%	0.0%
% Total	0.0%	60.1%	0.0%	60.1%	0.0%	0.0%	38.0%	0.4%	0.0%	38.5%	0.0%	0.0%	0.4%	1.0%	0.0%	1.5%	0.0%
PHF	0.000	0.870	0.000	0.870	0.000	0.000	0.863	0.500	0.000	0.873	0.000	0.000	0.500	0.417	0.000	0.438	0.000
Lights	0	269	0	269	0	0	166	1	0	167	0	0	1	4	0	5	0
% Lights	0.0%	93.1%	0.0%	93.1%	0.0%	0.0%	90.7%	50.0%	0.0%	90.3%	0.0%	0.0%	50.0%	80.0%	0.0%	71.4%	0.0%
Trucks	0	0	0	0	0	0	0	0	0	0	0	0	0	0	0	0	0
% Trucks	0.0%	0.0%	0.0%	0.0%	0.0%	0.0%	0.0%	0.0%	0.0%	0.0%	0.0%	0.0%	0.0%	0.0%	0.0%	0.0%	0.0%
Buses	0	20	0	20	0	0	17	1	0	18	0	0	1	1	0	2	0
% Buses	0.0%	6.9%	0.0%	0.0%	0.0%	0.0%	9.3%	50.0%	0.0%	0.0%	0.0%	0.0%	50.0%	20.0%	0.0%	0.0%	0.0%
Pedestrians	0	0	0	0	0	0	0	0	0	0	0	0	0	0	0	0	1
% Pedestrians	0.0%	0.0%	0.0%	0.0%	100.0%	0.0%	0.0%	0.0%	0.0%	0.0%	0.0%	0.0%	0.0%	0.0%	0.0%	0.0%	100.0%
Bicycles on Crosswalk	0	0	0	0	0	0	0	0	0	0	0	0	0	0	0	0	0
% Bicycles on Crosswalk	0.0%	0.0%	0.0%	0.0%	0.0%	0.0%	0.0%	0.0%	0.0%	0.0%	0.0%	0.0%	0.0%	0.0%	0.0%	0.0%	0.0%

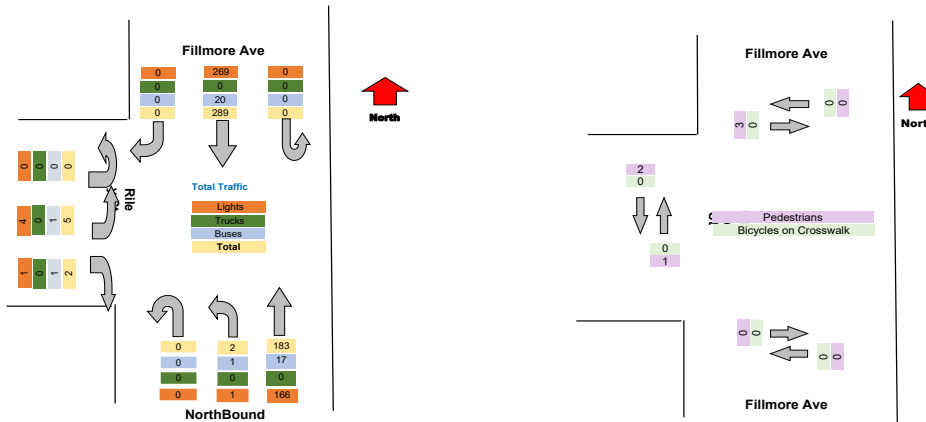

Turning Movement Peak Hour Data (PM)

4:45:00 PM

Leg Direction	Fillmore Ave Southbound						Fillmore Ave NorthBound						Riley St Eastbound					
	Right	Thru	U-Turn	App Total	Peds CW	Peds CCW	Thru	Left	U-Turn	App Total	Peds CW	Peds CCW	Right	Left	U-Turn	App Total	Peds CW	
4:45:00 PM	3	90	0	93	0	0	95	1	0	96	0	0	4	2	0	6	4	
5:00:00 PM	3	71	0	74	0	0	90	1	0	91	0	0	0	2	0	2	1	
5:15:00 PM	3	77	0	80	0	0	80	0	0	80	0	0	0	0	0	0	0	
5:30:00 PM	0	75	0	75	0	0	65	1	0	66	1	0	2	0	0	2	1	
<b>Grand Total</b>	<b>9</b>	<b>313</b>	<b>0</b>	<b>322</b>	<b>0</b>	<b>0</b>	<b>330</b>	<b>3</b>	<b>0</b>	<b>333</b>	<b>1</b>	<b>0</b>	<b>6</b>	<b>4</b>	<b>0</b>	<b>10</b>	<b>6</b>	
% Approach	2.8%	97.2%	0.0%	0.0%	0.0%	0.0%	99.1%	0.9%	0.0%	0.0%	0.0%	0.0%	60.0%	40.0%	0.0%	0.0%	0.0%	
% Total	1.4%	47.1%	0.0%	48.4%	0.0%	0.0%	49.6%	0.5%	0.0%	50.1%	0.0%	0.0%	0.9%	0.6%	0.0%	1.5%	0.0%	
PHF	0.750	0.869	0.000	0.866	0.000	0.000	0.868	0.750	0.000	0.867	0.000	0.000	0.375	0.500	0.000	0.417	0.000	
Lights	9	301	0	310	0	0	321	3	0	324	0	0	6	4	0	10	0	
% Lights	100.0%	96.2%	0.0%	96.3%	0.0%	0.0%	97.3%	100.0%	0.0%	97.3%	0.0%	0.0%	100.0%	100.0%	0.0%	100.0%	0.0%	
Trucks	0	2	0	2	0	0	1	0	0	1	0	0	0	0	0	0	0	
% Trucks	0.0%	0.6%	0.0%	0.6%	0.0%	0.0%	0.3%	0.0%	0.0%	0.3%	0.0%	0.0%	0.0%	0.0%	0.0%	0.0%	0.0%	
Buses	0	10	0	10	0	0	8	0	0	8	0	0	0	0	0	0	0	
% Buses	0.0%	3.2%	0.0%	0.0%	0.0%	0.0%	2.4%	0.0%	0.0%	0.0%	0.0%	0.0%	0.0%	0.0%	0.0%	0.0%	0.0%	
Pedestrians	0	0	0	0	0	0	0	0	0	1	0	0	0	0	0	0	6	
% Pedestrians	0.0%	0.0%	0.0%	0.0%	0.0%	0.0%	0.0%	0.0%	0.0%	0.0%	100.0%	0.0%	0.0%	0.0%	0.0%	0.0%	100.0%	
Bicycles on Crosswalk	0	0	0	0	0	0	0	0	0	0	0	0	0	0	0	0	0	
% Bicycles on Crosswalk	0.0%	0.0%	0.0%	0.0%	0.0%	0.0%	0.0%	0.0%	0.0%	0.0%	0.0%	0.0%	0.0%	0.0%	0.0%	0.0%	0.0%	

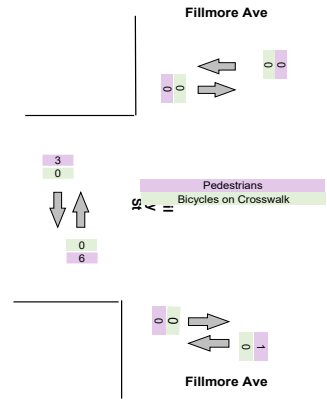
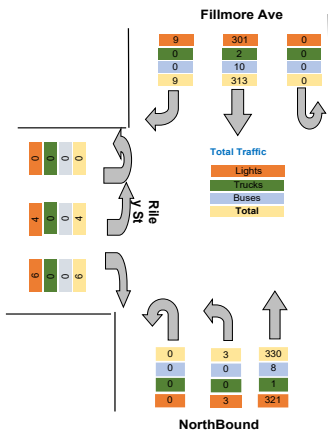

Intersection: Elm St Pine St  
 Location: Kennett Square, PA  
 Site: 01  
 Survey Date: Wednesday, 04-28-2021  
 GPS: 42.948550, -72.790034

Peds CCW	Total
0	34
2	59
2	93
1	62
1	57
2	98
0	117
4	334
0	137
0	129
0	266
3	161
0	162
2	163
0	195
5	681
1	167
0	160
2	143
1	146
4	616
15	1990
0.0%	0.0%
0.0%	0.0%
0	1865
0.0%	93.7%
0	3
0.0%	0.2%
0	122
0.0%	6.1%
15	0
100.0%	0.0%
0	0
0.0%	0.0%

Intersection: Elm St Pine St  
 Location: Kennett Square, PA  
 Site: 01  
 Survey Date: Wednesday, 04-28-2021  
 GPS: 42.948550, -72.790034



Peds CCW	<b>Total</b>
2	<b>98</b>
0	<b>117</b>
0	<b>137</b>
0	<b>129</b>
2	<b>481</b>
0.0%	
0.0%	
0.000	<b>0.878</b>
0	<b>441</b>
0.0%	<b>91.7%</b>
0	<b>0</b>
0.0%	<b>0.0%</b>
0	<b>40</b>
0.0%	<b>8.3%</b>
2	<b>0</b>
100.0%	<b>0.0%</b>
0	<b>0</b>
0.0%	<b>0.0%</b>



Intersection: Elm St Pine St  
 Location: Kennett Square, PA  
 Site: 01  
 Survey Date: Wednesday, 04-28-2021  
 GPS: 42.948550, -72.790034



Peds CCW	Total
0	195
1	167
0	160
2	143
3	665
0.0%	
0.0%	
0.000	0.853
0	644
0.0%	96.8%
0	3
0.0%	0.5%
0	18
0.0%	2.7%
3	0
100.0%	0.0%
0	0
0.0%	0.0%



Project : VBH Malta NY  
 Site : Site 4  
 Location : 42.948550, -73.790036  
 Survey Date : 2021-04-28, Wednesday

### Turning Movement Data Plot

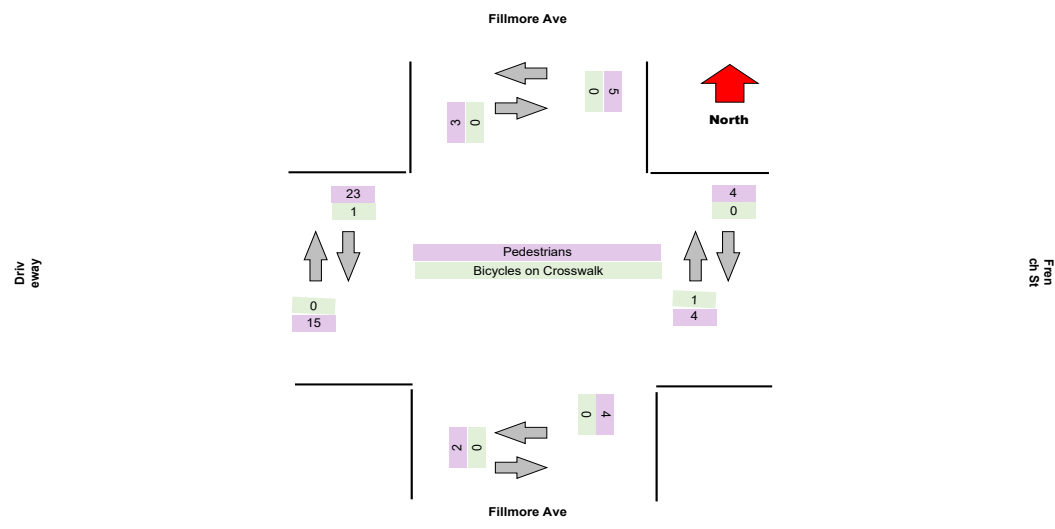
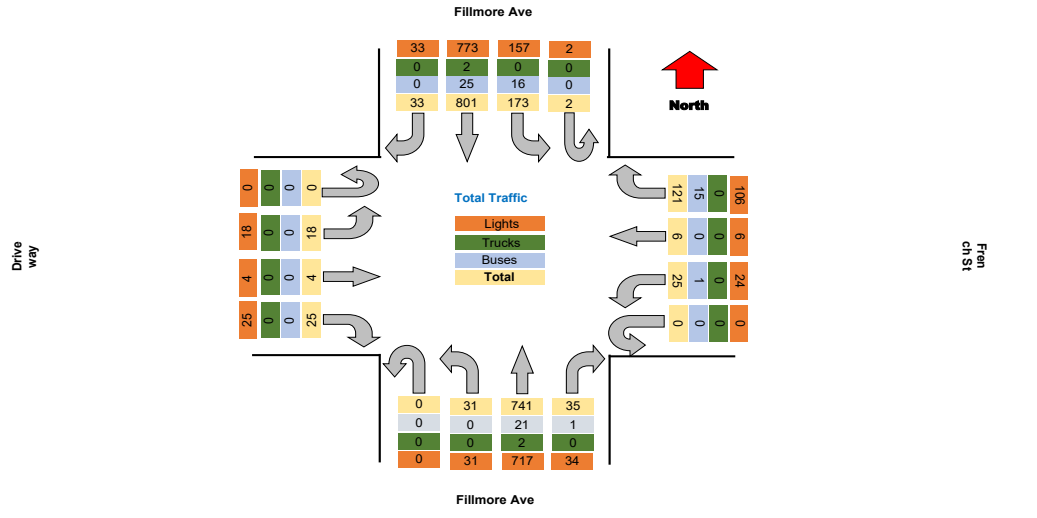

Project : VBH Malta NY  
Site : Site 4  
Location : 42.948550, -73.790036

TSTData.com

Survey Date : 2021-04-28, Wednesday

### Turning Movement Peak Hour Data (AM)

7:30:00 AM

Leg Direction	Fillmore Ave				French St				Fillmore Ave				Driveway				Total							
	Southbound		Westbound		Northbound		Eastbound																	
Start Time	Right	Thru	Left	U-Turn	App Total	Peds CW	Peds CCW	Right	Thru	Left	U-Turn	App Total	Peds CW	Peds CCW	Right	Thru	Left	U-Turn	App Total	Peds CW	Peds CCW			
7:30:00 AM	0	29	10	0	39	0	0	8	0	0	0	8	0	0	1	25	1	0	28	0	0	0	76	
7:45:00 AM	1	47	7	0	55	0	0	4	0	1	0	5	0	0	2	35	0	0	37	0	0	0	97	
8:00:00 AM	0	52	12	0	64	0	0	7	0	3	0	10	0	0	0	30	0	0	30	0	0	0	104	
8:15:00 AM	0	43	12	0	55	0	0	6	0	1	0	7	0	0	1	29	0	0	30	0	0	0	92	
<b>Grand Total</b>	<b>1</b>	<b>171</b>	<b>41</b>	<b>0</b>	<b>213</b>	<b>0</b>	<b>0</b>	<b>25</b>	<b>0</b>	<b>5</b>	<b>0</b>	<b>39</b>	<b>0</b>	<b>0</b>	<b>4</b>	<b>119</b>	<b>1</b>	<b>0</b>	<b>125</b>	<b>0</b>	<b>0</b>	<b>0</b>	<b>389</b>	
% Approach	0.5%	89.3%	19.2%	0.0%	0.0%	0.0%	0.0%	83.3%	0.0%	16.7%	0.0%	0.0%	0.0%	0.0%	3.2%	95.2%	0.8%	0.0%	0.0%	0.0%	0.0%	0.0%	0.0%	0.0%
% Total	0.3%	46.3%	11.1%	0.0%	57.7%	0.0%	0.0%	6.8%	0.0%	1.4%	0.0%	8.1%	0.0%	0.0%	1.1%	32.2%	0.3%	0.0%	33.9%	0.0%	0.0%	0.0%	0.0%	
PHF	0.250	0.822	0.854	0.000	0.832	0.000	0.000	0.781	0.000	0.417	0.000	0.750	0.000	0.000	0.500	0.850	0.250	0.000	0.845	0.000	0.000	0.000	0.887	
Lights	1	165	37	0	203	0	0	20	0	4	0	24	0	0	4	111	1	0	116	0	0	0	344	
% Lights	100.0%	96.5%	90.2%	0.0%	95.3%	0.0%	0.0%	80.0%	0.0%	80.0%	0.0%	80.0%	0.0%	0.0%	100.0%	93.3%	100.0%	0.0%	92.8%	0.0%	0.0%	0.0%	93.2%	
Trucks	0	0	0	0	0	0	0	0	0	0	0	0	0	0	0	0	0	0	0	0	0	0	0	
% Trucks	0.0%	0.0%	0.0%	0.0%	0.0%	0.0%	0.0%	0.0%	0.0%	0.0%	0.0%	0.0%	0.0%	0.0%	0.0%	0.0%	0.0%	0.0%	0.0%	0.0%	0.0%	0.0%	0.0%	
Buses	0	6	4	0	10	0	0	5	0	1	0	6	0	0	0	8	0	0	8	0	0	0	24	
% Buses	0.0%	3.5%	9.8%	0.0%	0.0%	0.0%	0.0%	20.0%	0.0%	20.0%	0.0%	0.0%	0.0%	0.0%	0.0%	6.7%	0.0%	0.0%	0.0%	0.0%	0.0%	0.0%	0.0%	6.5%
Pedestrians	0	0	0	0	0	0	0	0	0	0	0	0	1	0	0	0	0	0	0	0	0	0	1	
% Pedestrians	0.0%	0.0%	0.0%	0.0%	0.0%	0.0%	0.0%	0.0%	0.0%	0.0%	0.0%	0.0%	0.0%	100.0%	0.0%	0.0%	0.0%	0.0%	0.0%	0.0%	0.0%	0.0%	100.0%	0.0%
Bicycles on Crosswalk	0	0	0	0	0	0	0	0	0	0	0	0	0	0	0	0	0	0	0	0	0	0	0	
% Bicycles on Crosswalk	0.0%	0.0%	0.0%	0.0%	0.0%	0.0%	0.0%	0.0%	0.0%	0.0%	0.0%	0.0%	0.0%	0.0%	0.0%	0.0%	0.0%	0.0%	0.0%	0.0%	0.0%	0.0%	0.0%	

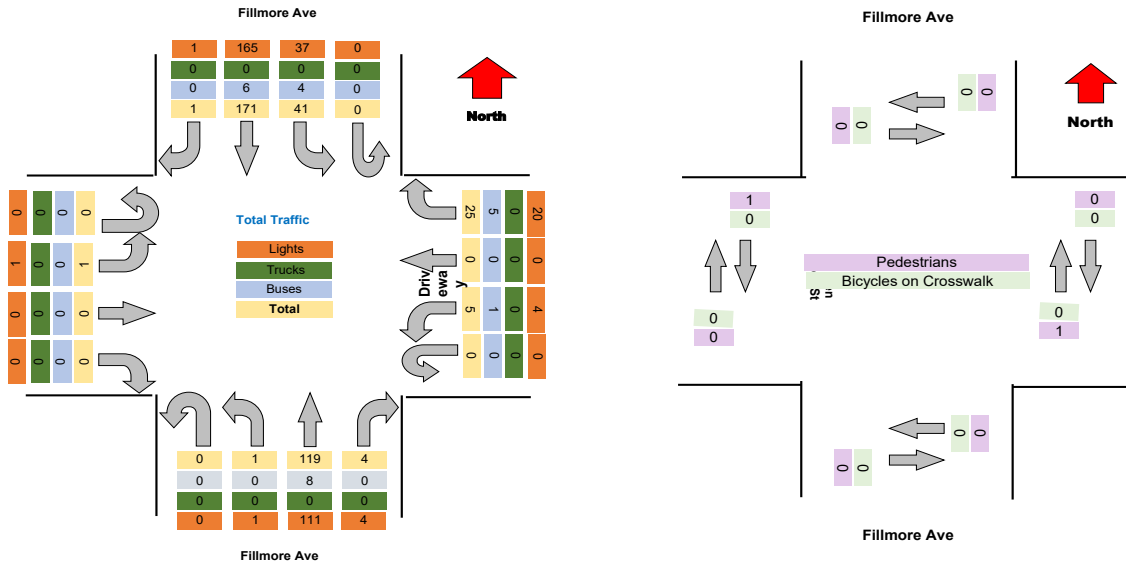

**Turning Movement Peak Hour Data (PM)**

4:45:00 PM

Leg Direction	Fillmore Ave				French St				Fillmore Ave				Driveway				Total													
	Southbound				Westbound				Northbound				Eastbound																	
Start Time	Right	Thru	Left	U-Turn	App Total	Peds CW	Peds CCW	Right	Thru	Left	U-Turn	App Total	Peds CW	Peds CCW	Right	Thru	Left	U-Turn	App Total	Peds CW	Peds CCW									
4:45:00 PM	3	69	14	1	87	0	0	10	1	1	0	12	0	0	1	75	6	0	82	0	0	2	0	3	0	5	3	7	186	
5:00:00 PM	6	75	14	1	96	1	0	12	0	3	0	15	1	0	5	70	4	0	79	0	0	2	1	1	0	4	1	1	194	
5:15:00 PM	6	55	16	0	77	0	0	13	0	3	0	16	0	0	3	70	4	0	77	1	1	3	1	1	0	5	0	2	175	
5:30:00 PM	4	60	14	0	78	0	0	9	3	4	0	16	0	0	3	65	4	0	72	1	0	2	0	3	0	5	3	3	171	
<b>Grand Total</b>	<b>19</b>	<b>259</b>	<b>58</b>	<b>2</b>	<b>338</b>	<b>0</b>	<b>0</b>	<b>44</b>	<b>4</b>	<b>11</b>	<b>0</b>	<b>59</b>	<b>1</b>	<b>0</b>	<b>12</b>	<b>290</b>	<b>18</b>	<b>0</b>	<b>310</b>	<b>2</b>	<b>1</b>	<b>9</b>	<b>2</b>	<b>8</b>	<b>0</b>	<b>19</b>	<b>7</b>	<b>13</b>	<b>726</b>	
% Approach	5.6%	76.6%	17.2%	0.6%	0.0%	0.0%	0.0%	74.6%	6.8%	18.6%	0.0%	0.0%	0.0%	0.0%	3.9%	90.3%	5.8%	0.0%	0.0%	0.0%	0.0%	47.4%	10.5%	42.1%	0.0%	0.0%	0.0%	0.0%	0.0%	
% Total	2.6%	35.7%	8.0%	0.3%	46.6%	0.0%	0.0%	6.1%	0.6%	1.5%	0.0%	8.1%	0.0%	0.0%	1.7%	38.6%	2.5%	0.0%	42.7%	0.0%	0.0%	1.2%	0.3%	1.1%	0.0%	2.6%	0.0%	0.0%		
PHF	0.792	0.863	0.906	0.500	0.890	0.000	0.000	0.846	0.333	0.688	0.000	0.922	0.000	0.000	0.600	0.933	0.750	0.000	0.845	0.000	0.000	0.750	0.500	0.667	0.000	0.950	0.000	0.000	0.936	
Lights	19	251	55	2	327	0	0	41	4	11	0	56	0	0	12	273	18	0	303	0	0	9	2	8	0	19	0	0	705	
% Lights	100.0%	96.9%	94.8%	100.0%	96.7%	0.0%	0.0%	83.2%	100.0%	100.0%	0.0%	94.9%	0.0%	0.0%	100.0%	97.6%	100.0%	0.0%	97.7%	0.0%	0.0%	100.0%	100.0%	100.0%	0.0%	100.0%	0.0%	0.0%	97.1%	
Trucks	0	1	0	0	1	0	0	0	0	0	0	0	0	0	0	2	0	0	2	0	0	0	0	0	0	0	0	0	3	
% Trucks	0.0%	0.4%	0.0%	0.0%	0.3%	0.0%	0.0%	0.0%	0.0%	0.0%	0.0%	0.0%	0.0%	0.0%	0.0%	0.7%	0.0%	0.0%	0.6%	0.0%	0.0%	0.0%	0.0%	0.0%	0.0%	0.0%	0.0%	0.0%	0.4%	
Buses	0	7	3	0	10	0	0	3	0	0	0	3	0	0	0	4	0	0	4	0	0	0	0	0	0	0	0	0	17	
% Buses	0.0%	2.7%	5.2%	0.0%	0.0%	0.0%	0.0%	6.8%	0.0%	0.0%	0.0%	0.0%	0.0%	0.0%	0.0%	1.4%	0.0%	0.0%	0.0%	0.0%	0.0%	0.0%	0.0%	0.0%	0.0%	0.0%	0.0%	0.0%	2.3%	
Pedestrians	0	0	0	0	0	2	2	0	0	0	0	0	1	0	0	0	0	0	0	2	1	0	0	0	0	0	7	13	0	
% Pedestrians	0.0%	0.0%	0.0%	0.0%	0.0%	100.0%	100.0%	0.0%	0.0%	0.0%	0.0%	0.0%	0.0%	0.0%	0.0%	0.0%	0.0%	0.0%	0.0%	0.6%	100.0%	100.0%	0.0%	0.0%	0.0%	0.0%	0.0%	0.0%	100.0%	0.0%
Bicycles on Crosswalk	0	0	0	0	0	0	0	0	0	0	0	0	0	0	0	0	0	0	0	0	0	0	0	0	0	0	0	0	0	
% Bicycles on Crosswalk	0.0%	0.0%	0.0%	0.0%	0.0%	0.0%	0.0%	0.0%	0.0%	0.0%	0.0%	0.0%	0.0%	0.0%	0.0%	0.0%	0.0%	0.0%	0.0%	0.0%	0.0%	0.0%	0.0%	0.0%	0.0%	0.0%	0.0%	0.0%	0.0%	

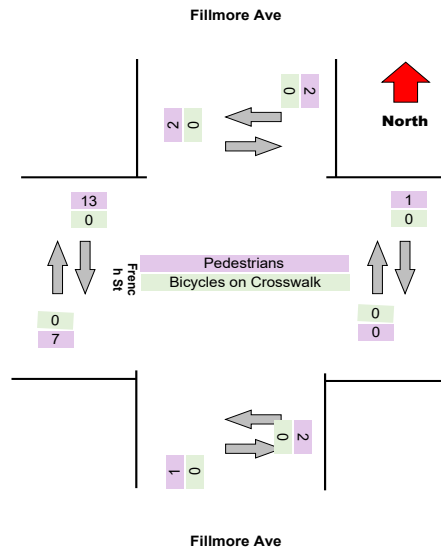
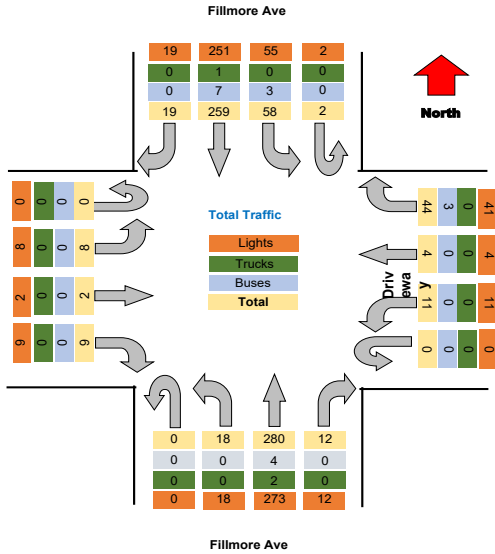

Project : VBH Malta NY  
 Site : Site 4  
 Location : 42.948550, -73.790036

TSTData.com

Survey Date : 2021-04-28, Wednesday

Project	LaBella
Project Code	LaBella
Site Name	22
Legs and Movements	All Processed Legs & Move
Bin Size	15 minutes
Survey Date	2021-11-03, Wednesday
Location	22
Latitude and Longitude	42.910500, -78.839058

	Start	End	PHF
Forced Peak AM	2021/11/03 07:30:00	2021/11/03 08:30:00	0.86
Forced Peak PM	2021/11/03 16:30:00	2021/11/03 17:30:00	0.85
AM Peak	2021/11/03 07:30:00	2021/11/03 08:30:00	0.86
PM Peak	2021/11/03 16:45:00	2021/11/03 17:45:00	0.92

### Turning Movement Data

Leg Direction	Fillmore Ave										French St										Fillmore Ave										Driveway										Total
	Southbound					Westbound					Northbound					Eastbound					Northbound					Eastbound															
	Right	Thru	Left	U-Turn	App Total	Right	Thru	Left	U-Turn	App Total	Right	Thru	Left	U-Turn	App Total	Right	Thru	Left	U-Turn	App Total	Right	Thru	Left	U-Turn	App Total	Right	Thru	Left	U-Turn	App Total	Right	Thru	Left	U-Turn	App Total						
6:30:00 AM	0	22	6	0	28	0	0	0	0	0	2	0	0	0	2	0	0	0	0	0	1	22	0	0	24	0	0	0	0	0	0	0	0	0	0	0	0	0	0	0	54
6:45:00 AM	0	32	5	0	37	0	0	0	0	0	7	0	1	0	8	0	0	0	0	0	0	29	0	0	29	0	0	0	0	0	0	0	0	0	0	0	0	0	0	0	74
Hourly Total	0	54	11	0	65	0	0	0	0	0	9	0	1	0	10	0	0	0	0	0	1	51	0	0	53	0	0	0	0	0	0	0	0	0	0	0	0	0	0	0	128
7:00:00 AM	0	36	10	0	46	0	0	1	0	1	8	0	1	0	10	2	0	0	0	2	0	29	0	0	31	2	0	0	0	2	1	0	0	0	1	2	0	0	0	2	88
7:15:00 AM	0	45	7	0	52	0	0	0	0	0	6	0	2	0	8	0	2	0	0	2	0	28	0	0	30	0	0	0	0	0	0	0	0	0	0	1	2	0	0	3	90
7:30:00 AM	0	59	7	0	66	1	2	0	0	3	6	0	2	0	8	0	8	3	0	3	0	37	0	0	48	0	2	1	0	3	1	0	0	0	1	1	1	0	0	2	125
7:45:00 AM	0	81	12	0	93	0	0	0	0	0	10	0	2	0	12	8	0	0	0	8	1	60	0	0	69	0	2	0	0	2	0	0	0	0	0	0	0	0	0	0	174
Hourly Total	0	221	36	0	257	1	3	0	0	4	30	0	7	0	40	18	8	3	0	5	1	154	0	0	178	2	4	2	0	4	2	0	0	0	2	4	4	0	0	4	477
8:00:00 AM	0	72	15	0	87	0	1	0	0	1	7	0	1	0	9	0	0	0	0	0	0	48	0	0	49	0	0	0	0	0	0	1	0	0	1	0	0	0	0	0	146
8:15:00 AM	0	68	10	0	78	0	0	0	0	0	9	0	0	0	9	6	1	0	0	1	3	56	0	0	66	1	0	0	0	1	0	0	0	0	0	1	0	0	0	1	153
Hourly Total	0	140	25	0	165	0	1	0	0	1	16	0	1	0	18	6	2	0	0	2	3	104	0	0	115	1	0	0	0	1	0	1	0	0	1	1	0	0	0	1	299
4:00:00 PM	2	74	14	0	90	0	4	0	0	4	11	1	5	0	17	1	2	0	0	2	3	67	3	0	73	3	2	1	0	2	1	0	1	0	2	7	6	0	0	6	182
4:15:00 PM	5	81	12	0	98	2	4	0	0	4	12	0	4	0	16	4	5	0	0	5	2	82	5	0	89	1	0	1	0	1	0	0	0	0	0	1	4	6	0	6	204
4:30:00 PM	1	102	25	0	128	2	1	0	0	1	13	0	3	0	16	3	1	0	0	1	8	56	1	0	65	0	0	0	0	0	0	0	1	0	1	1	5	0	0	5	210
4:45:00 PM	2	83	13	0	95	0	1	0	0	1	9	0	1	0	10	0	2	0	0	2	5	90	4	0	99	0	0	1	0	1	0	0	0	0	0	1	1	3	0	3	208
Hourly Total	10	340	64	0	414	4	10	0	0	10	45	1	13	0	59	8	10	0	0	10	18	295	13	0	326	4	2	3	0	2	3	0	2	0	5	13	22	0	0	22	804
5:00:00 PM	3	75	15	0	93	2	1	0	0	1	11	2	2	0	15	1	4	0	0	4	5	73	4	0	82	0	0	3	1	1	0	1	0	0	1	1	1	0	0	1	195
5:15:00 PM	2	78	18	0	98	0	2	0	0	2	9	1	4	0	14	0	2	0	0	2	3	67	0	0	70	0	0	2	0	3	0	3	0	0	3	5	1	2	0	2	187
5:30:00 PM	0	68	17	0	85	1	1	0	0	1	16	0	4	0	20	0	1	0	0	1	3	62	3	0	68	0	3	5	0	0	0	0	0	0	0	5	6	2	0	7	178
5:45:00 PM	1	64	10	0	75	2	1	0	0	1	10	0	2	0	12	5	1	0	0	1	6	62	5	0	73	0	0	0	0	0	0	1	4	0	5	4	2	0	0	2	165
Hourly Total	6	285	60	0	351	5	5	0	0	5	46	3	12	0	61	6	8	0	0	8	17	264	12	0	293	0	3	10	2	8	0	20	12	0	9	725					
Grand Total	16	1040	196	0	1252	19	19	0	0	19	146	4	34	0	188	38	38	0	0	38	40	868	25	0	965	7	9	15	3	10	0	28	30	0	36	2433					
% Approach	1.3%	83.1%	15.7%	0.0%	0.0%	0.0%	0.0%	0.0%	0.0%	0.0%	77.7%	2.1%	18.1%	0.0%	0.0%	0.0%	0.0%	0.0%	0.0%	0.0%	4.1%	89.9%	2.6%	0.0%	0.0%	0.0%	0.0%	53.6%	10.7%	35.7%	0.0%	0.0%	0.0%	0.0%	0.0%	0.0%					
% Total	0.7%	42.7%	8.1%	0.0%	51.5%	0.0%	0.0%	0.0%	0.0%	0.0%	6.0%	0.2%	1.4%	0.0%	7.7%	0.0%	0.0%	0.0%	0.0%	0.0%	1.6%	35.7%	1.0%	0.0%	39.7%	0.0%	0.0%	8.6%	0.1%	6.4%	0.0%	1.2%	0.0%	0.0%	0.0%	0.0%					
Lights	16	969	172	0	1157	0	0	0	0	0	123	4	28	0	155	0	0	0	0	0	39	807	25	0	871	0	0	15	3	10	0	28	0	0	0	2211					
% Lights	100.0%	93.2%	87.8%	0.0%	92.4%	0.0%	0.0%	0.0%	0.0%	0.0%	84.2%	100.0%	82.4%	0.0%	82.4%	0.0%	0.0%	0.0%	0.0%	0.0%	97.5%	83.0%	100.0%	0.0%	90.3%	0.0%	0.0%	100.0%	100.0%	0.0%	100.0%	0.0%	0.0%	0.0%	0.0%	90.9%					
Trucks	0	2	1	0	3	0	0	0	0	0	0	0	0	0	0	0	0	0	0	0	0	2	0	0	2	0	0	0	0	0	0	0	0	0	0	5					
% Trucks	0.0%	0.2%	0.5%	0.0%	0.2%	0.0%	0.0%	0.0%	0.0%	0.0%	0.0%	0.0%	0.0%	0.0%	0.0%	0.0%	0.0%	0.0%	0.0%	0.0%	0.0%	0.2%	0.0%	0.0%	0.2%	0.0%	0.0%	0.0%	0.0%	0.0%	0.0%	0.0%	0.0%	0.0%	0.0%	0.2%					
Buses	0	69	23	0	92	0	0	0	0	0	23	0	6	0	29	0	0	0	0	0	1	59	0	0	60	0	0	0	0	0	0	0	0	0	0	0	0	0	0	0	161
% Buses	0.0%	6.6%	11.7%	0.0%	0.0%	0.0%	0.0%	0.0%	0.0%	0.0%	0.0%	0.0%	17.6%	0.0%	0.0%	0.0%	0.0%	0.0%	0.0%	0.0%	2.5%	6.8%	0.0%	0.0%	0.0%	0.0%	0.0%	0.0%	0.0%	0.0%	0.0%	0.0%	0.0%	0.0%	0.0%	7.4%					
Pedestrians	0	0	0	0	0	0	0	0	0	0	0	0	0	0	0	35	22	0	0	0	0	0	0	0	0	7	9	0	0	0	0	0	0	0	0	30	36	0	0	0	0
% Pedestrians	0.0%	0.0%	0.0%	0.0%	0.0%	0.0%	0.0%	0.0%	0.0%	0.0%	0.0%	0.0%	0.0%	0.0%	0.0%	92.1%	84.9%	0.0%	0.0%	0.0%	0.0%	0.0%	0.0%	0.0%	0.0%	100.0%	100.0%	0.0%	0.0%	0.0%	0.0%	0.0%	0.0%	0.0%	0.0%	100.0%	100.0%	0.0%	0.0%	0.0%	0.0%
Bicycles on Crosswalk	0	0	0	0	0	0	0	0	0	0	0	0	0	0	0	3	4	0	0	0	0	0	0	0	0	0	0	0	0	0	0	0	0	0	0	0	0	0	0	0	0
% Bicycles on Crosswalk	0.0%	0.0%	0.0%	0.0%	0.0%	0.0%	0.0%	0.0%	0.0%	0.0%	0.0%	0.0%	0.0%	0.0%	0.0%	7.9%	15.4%	0.0%	0.0%	0.0%	0.0%	0.0%	0.0%	0.0%	0.0%	0.0%	0.0%	0.0%	0.0%	0.0%	0.0%	0.0%	0.0%	0.0%	0.0%	0.0%	0.0%	0.0%	0.0%	0.0%	0.0%

Project : VBH Malta NY  
 Site : Site 4  
 Location : 42.948550, -73.790036  
 Survey Date : 2021-04-28, Wednesday

### Turning Movement Data Plot

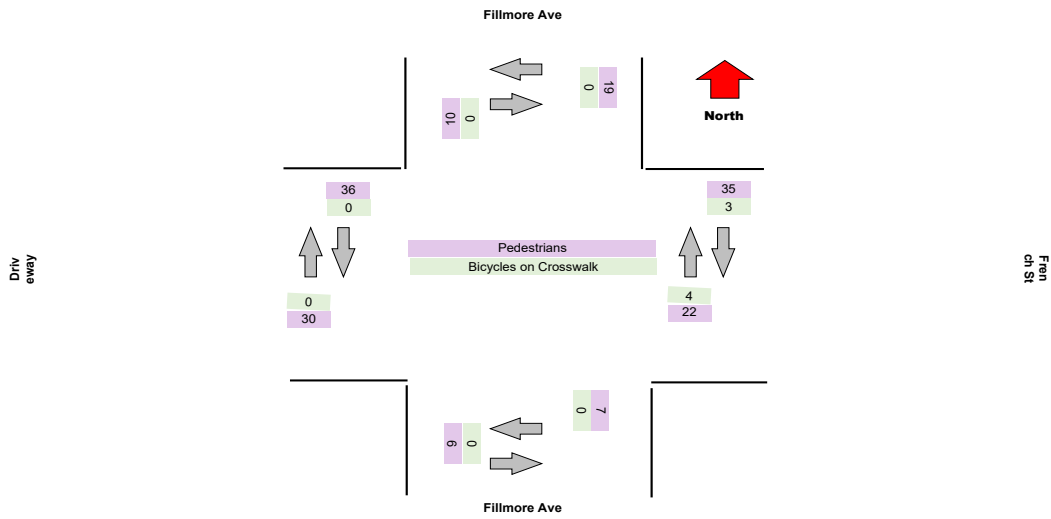
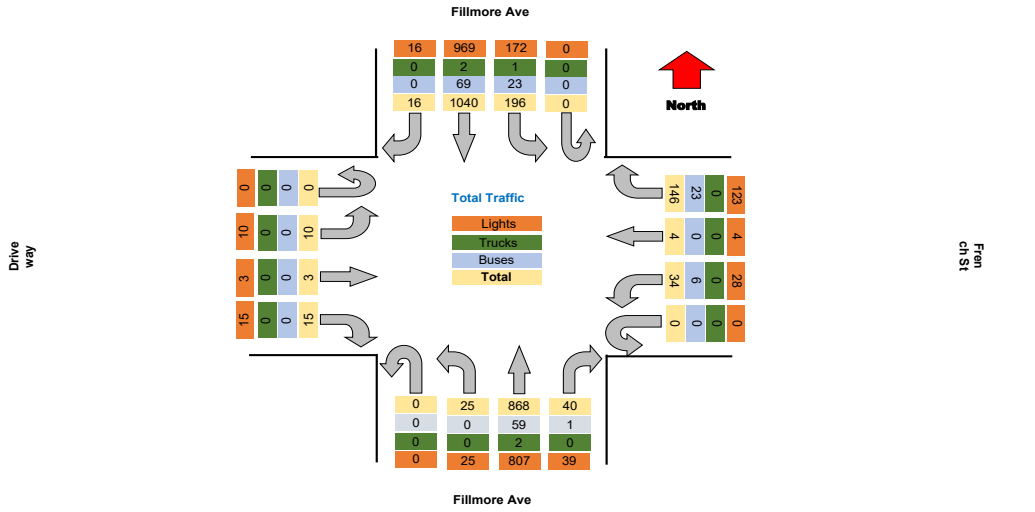

Project : VBH Malta NY  
Site : Site 4  
Location : 42.948550, -73.790036

TSTData.com

Survey Date : 2021-04-28, Wednesday

### Turning Movement Peak Hour Data (AM)

7:30:00 AM

Leg Direction	Fillmore Ave Southbound					French St Westbound					Fillmore Ave Northbound					Driveway Eastbound					Total					
	Right	Thru	Left	U-Turn	App Total	Peds CW	Peds CCW	Right	Thru	Left	U-Turn	App Total	Peds CW	Peds CCW	Right	Thru	Left	U-Turn	App Total	Peds CW		Peds CCW				
7:30:00 AM	0	59	7	0	66	1	2	6	0	2	0	10	8	3	0	37	0	0	48	0	2	1	1	1	125	
7:45:00 AM	0	81	12	0	93	0	0	10	0	2	0	12	8	0	0	1	60	0	0	69	0	0	0	0	1	174
8:00:00 AM	0	72	15	0	87	0	1	7	0	1	0	9	0	1	0	0	48	0	0	49	0	0	0	1	0	146
8:15:00 AM	0	68	10	0	78	0	0	9	0	0	0	9	0	0	0	3	56	0	0	66	1	0	0	0	1	153
Grand Total	0	289	44	0	324	1	3	32	0	5	0	49	22	5	4	4	231	0	0	232	1	4	1	1	2	598
% Approach	0.0%	86.4%	13.6%	0.0%	0.0%	0.0%	0.0%	80.0%	0.0%	12.5%	0.0%	0.0%	0.0%	0.0%	1.7%	86.6%	0.0%	0.0%	0.0%	0.0%	0.0%	50.0%	50.0%	0.0%	0.0%	
% Total	0.0%	46.8%	7.4%	0.0%	54.2%	0.0%	0.0%	5.4%	0.0%	0.8%	0.0%	6.7%	0.0%	0.0%	0.7%	33.6%	0.0%	0.0%	38.8%	0.0%	0.0%	0.2%	0.2%	0.0%	0.3%	
PHF	0.000	0.864	0.733	0.000	0.871	0.000	0.000	0.800	0.000	0.625	0.000	0.833	0.000	0.000	0.333	0.838	0.000	0.000	0.841	0.000	0.000	0.250	0.250	0.000	0.500	
Lights	0	261	39	0	300	0	0	24	0	2	0	26	0	0	4	177	0	0	181	0	0	1	1	0	2	
% Lights	0.0%	93.2%	88.6%	0.0%	92.6%	0.0%	0.0%	75.0%	0.0%	40.0%	0.0%	65.0%	0.0%	0.0%	100.0%	88.1%	0.0%	0.0%	78.0%	0.0%	0.0%	100.0%	100.0%	0.0%	100.0%	
Trucks	0	0	0	0	0	0	0	0	0	0	0	0	0	0	0	0	0	0	0	0	0	0	0	0	0	
% Trucks	0.0%	0.0%	0.0%	0.0%	0.0%	0.0%	0.0%	0.0%	0.0%	0.0%	0.0%	0.0%	0.0%	0.0%	0.0%	0.0%	0.0%	0.0%	0.0%	0.0%	0.0%	0.0%	0.0%	0.0%	0.0%	
Buses	0	19	5	0	24	0	0	8	0	3	0	11	0	0	0	24	0	0	24	0	0	0	0	0	0	
% Buses	0.0%	6.8%	11.4%	0.0%	0.0%	0.0%	0.0%	25.0%	0.0%	60.0%	0.0%	0.0%	0.0%	0.0%	0.0%	11.9%	0.0%	0.0%	0.0%	0.0%	0.0%	0.0%	0.0%	0.0%	0.0%	
Pedestrians	0	0	0	0	0	1	3	0	0	0	0	0	21	5	0	0	0	0	1	4	0	0	0	0	2	
% Pedestrians	0.0%	0.0%	0.0%	0.0%	0.0%	100.0%	100.0%	0.0%	0.0%	0.0%	0.0%	0.0%	95.9%	100.0%	0.0%	0.0%	0.0%	0.0%	0.0%	100.0%	100.0%	0.0%	0.0%	0.0%	100.0%	
Bicycles on Crosswalk	0	0	0	0	0	0	0	0	0	0	0	1	0	0	0	0	0	0	0	0	0	0	0	0	0	
% Bicycles on Crosswalk	0.0%	0.0%	0.0%	0.0%	0.0%	0.0%	0.0%	0.0%	0.0%	0.0%	0.0%	4.5%	0.0%	0.0%	0.0%	0.0%	0.0%	0.0%	0.0%	0.0%	0.0%	0.0%	0.0%	0.0%	0.0%	

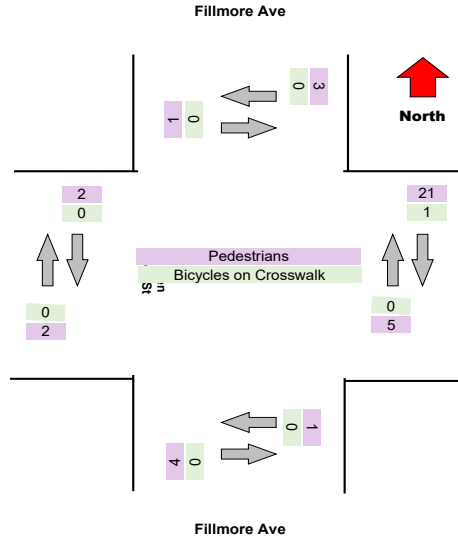
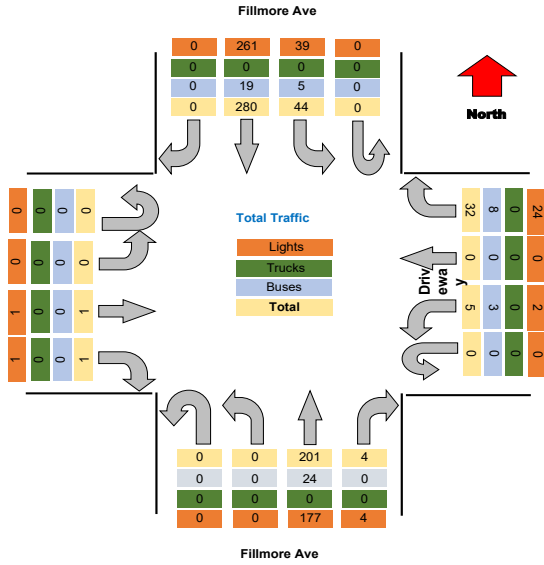



**Turning Movement Peak Hour Data (PM)**

4:45:00 PM

Leg Direction	Fillmore Ave						French St						Fillmore Ave						Driveway						Total					
	Southbound			Northbound			Westbound			Eastbound			Northbound			Eastbound														
Start Time	Right	Thru	Left	U-Turn	App Total	Peds CW	Peds CCW	Right	Thru	Left	U-Turn	App Total	Peds CW	Peds CCW	Right	Thru	Left	U-Turn	App Total	Peds CW	Peds CCW	Right	Thru	Left	U-Turn	App Total	Peds CW	Peds CCW		
4:45:00 PM	2	83	13	0	98	0	1	9	0	1	0	10	0	2	5	90	4	0	99	0	0	1	0	0	1	1	3	208		
5:00:00 PM	3	75	15	0	93	2	1	11	2	2	0	15	1	4	5	73	4	0	82	0	0	3	1	1	0	5	1	3	196	
5:15:00 PM	2	78	18	0	98	0	2	9	1	4	0	14	0	2	3	67	0	0	70	0	0	2	0	3	0	5	1	2	187	
5:30:00 PM	0	58	17	0	75	1	1	16	0	4	0	20	0	1	3	52	3	0	55	0	3	5	0	0	0	5	6	2	178	
<b>Grand Total</b>	<b>7</b>	<b>304</b>	<b>63</b>	<b>0</b>	<b>374</b>	<b>3</b>	<b>5</b>	<b>45</b>	<b>3</b>	<b>11</b>	<b>0</b>	<b>59</b>	<b>1</b>	<b>9</b>	<b>16</b>	<b>292</b>	<b>11</b>	<b>0</b>	<b>319</b>	<b>0</b>	<b>3</b>	<b>11</b>	<b>1</b>	<b>4</b>	<b>0</b>	<b>16</b>	<b>3</b>	<b>10</b>	<b>768</b>	
% Approach	1.9%	81.3%	16.6%	0.0%	0.0%	0.0%	0.0%	76.3%	5.1%	18.6%	0.0%	0.0%	0.0%	0.0%	5.0%	91.5%	3.4%	0.0%	0.0%	0.0%	0.0%	68.8%	6.3%	25.0%	0.0%	0.0%	0.0%	0.0%	0.0%	
% Total	0.9%	39.6%	8.2%	0.0%	48.7%	0.0%	0.0%	5.9%	0.4%	1.4%	0.0%	7.7%	0.0%	0.0%	2.1%	38.0%	1.4%	0.0%	41.5%	0.0%	0.0%	1.4%	0.1%	0.5%	0.0%	2.1%	0.0%	0.0%		
PHF	0.583	0.916	0.875	0.000	0.954	0.000	0.000	0.703	0.375	0.688	0.000	0.738	0.000	0.000	0.800	0.811	0.688	0.000	0.806	0.000	0.000	0.550	0.250	0.333	0.000	0.800	0.000	0.000	0.923	
Lights	7	296	58	0	361	0	0	40	3	11	0	54	0	0	16	282	11	0	309	0	0	11	1	4	0	16	0	0	740	
% Lights	100.0%	97.4%	92.1%	0.0%	96.5%	0.0%	0.0%	88.9%	100.0%	100.0%	0.0%	91.5%	0.0%	0.0%	100.0%	96.6%	100.0%	0.0%	96.9%	0.0%	0.0%	100.0%	100.0%	100.0%	0.0%	100.0%	0.0%	0.0%	96.4%	
Trucks	0	0	0	0	0	0	0	0	0	0	0	0	0	0	0	1	0	0	1	0	0	0	0	0	0	0	0	0	1	
% Trucks	0.0%	0.0%	0.0%	0.0%	0.0%	0.0%	0.0%	0.0%	0.0%	0.0%	0.0%	0.0%	0.0%	0.0%	0.0%	0.3%	0.0%	0.0%	0.3%	0.0%	0.0%	0.0%	0.0%	0.0%	0.0%	0.0%	0.0%	0.0%	0.1%	
Buses	0	8	5	0	13	0	0	5	0	0	0	5	0	0	0	9	0	0	9	0	0	0	0	0	0	0	0	0	27	
% Buses	0.0%	2.6%	7.9%	0.0%	0.0%	0.0%	0.0%	11.1%	0.0%	0.0%	0.0%	0.0%	0.0%	0.0%	0.0%	3.1%	0.0%	0.0%	0.0%	0.0%	0.0%	0.0%	0.0%	0.0%	0.0%	0.0%	0.0%	0.0%	3.5%	
Pedestrians	0	0	0	0	0	3	5	0	0	0	0	0	1	6	0	0	0	0	0	0	3	0	0	0	0	0	9	10	0	
% Pedestrians	0.0%	0.0%	0.0%	0.0%	0.0%	100.0%	100.0%	0.0%	0.0%	0.0%	0.0%	0.0%	100.0%	66.7%	0.0%	0.0%	0.0%	0.0%	0.0%	0.0%	0.0%	100.0%	0.0%	0.0%	0.0%	0.0%	0.0%	100.0%	100.0%	0.0%
Bicycles on Crosswalk	0	0	0	0	0	0	0	0	0	0	0	0	0	0	0	0	0	0	0	0	0	0	0	0	0	0	0	0	0	
% Bicycles on Crosswalk	0.0%	0.0%	0.0%	0.0%	0.0%	0.0%	0.0%	0.0%	0.0%	0.0%	0.0%	0.0%	0.0%	33.3%	0.0%	0.0%	0.0%	0.0%	0.0%	0.0%	0.0%	0.0%	0.0%	0.0%	0.0%	0.0%	0.0%	0.0%	0.0%	

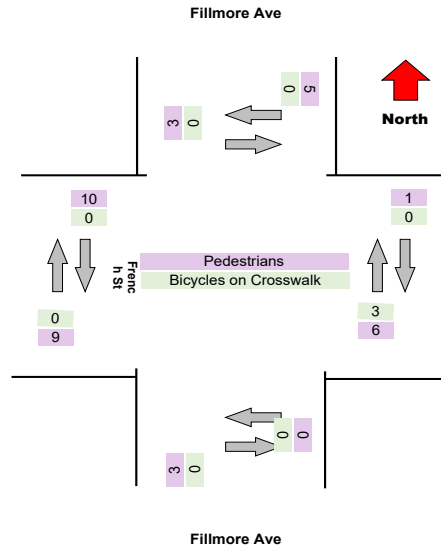
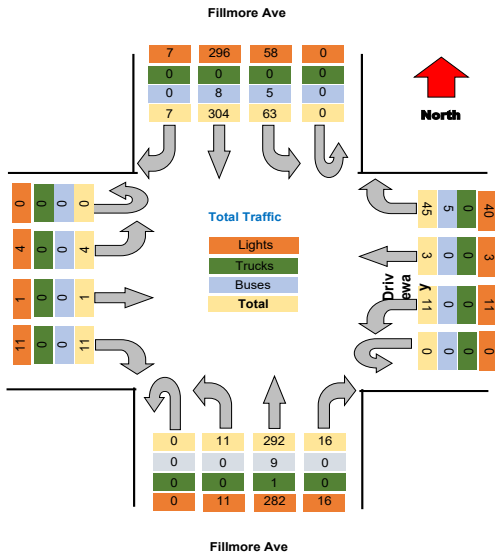



Project : VBH Malta NY  
 Site : Site 4  
 Location : 42.948550, -73.790036  
 Survey Date : 2021-04-28, Wednesday

### Turning Movement Data Plot

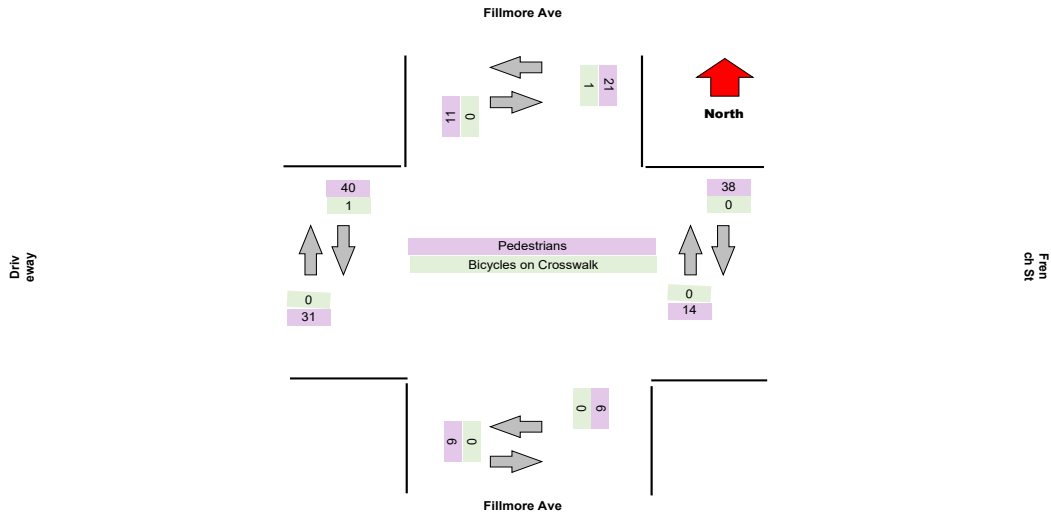
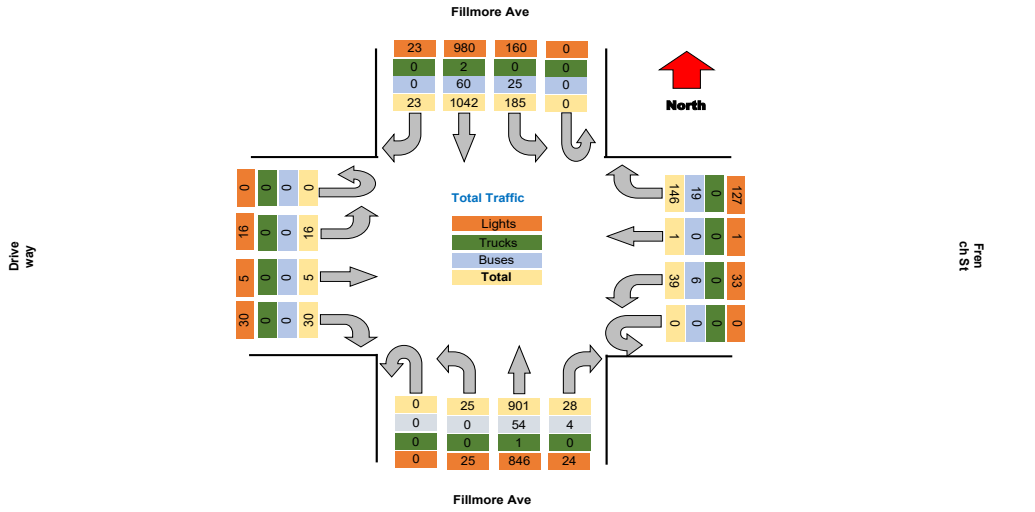

**Turning Movement Peak Hour Data (AM)**

7:30:00 AM

Leg Direction	Fillmore Ave Southbound					French St Westbound					Fillmore Ave Northbound					Driveway Eastbound					Total								
	Right	Thru	Left	U-Turn	App Total	Peds CW	Peds CCW	Right	Thru	Left	U-Turn	App Total	Peds CW	Peds CCW	Right	Thru	Left	U-Turn	App Total	Peds CW		Peds CCW							
7:30:00 AM	0	65	9	0	74	2	0	9	0	2	0	11	8	2	1	36	0	0	47	0	1	1	0	0	0	1	1	133	
7:45:00 AM	0	71	10	0	81	2	0	8	0	3	0	13	12	0	0	47	0	0	59	0	0	0	0	0	0	0	1	3	163
8:00:00 AM	0	83	13	0	96	1	1	4	0	4	0	9	4	1	1	46	0	0	52	0	0	0	0	0	0	0	1	1	157
8:15:00 AM	0	75	7	0	82	0	0	11	0	2	0	13	0	0	1	59	0	0	61	0	0	0	1	0	0	1	1	0	157
Grand Total	0	294	39	0	333	3	0	32	0	11	0	45	25	3	3	195	0	0	219	0	1	1	1	0	0	2	3	5	600
% Approach	0.0%	88.3%	11.7%	0.0%	0.0%	0.0%	0.0%	89.6%	0.0%	23.9%	0.0%	0.0%	0.0%	0.0%	1.4%	85.8%	0.0%	0.0%	0.0%	0.0%	0.0%	50.0%	50.0%	0.0%	0.0%	0.0%	0.0%	0.0%	0.0%
% Total	0.0%	49.0%	6.5%	0.0%	55.5%	0.0%	0.0%	5.3%	0.0%	1.8%	0.0%	7.7%	0.0%	0.0%	0.5%	31.3%	0.0%	0.0%	36.5%	0.0%	0.0%	0.2%	0.2%	0.0%	0.0%	0.3%	0.0%	0.0%	0.0%
PHF	0.000	0.886	0.750	0.000	0.867	0.000	0.000	0.727	0.000	0.688	0.000	0.885	0.000	0.000	0.750	0.797	0.000	0.000	0.898	0.000	0.000	0.250	0.250	0.000	0.000	0.500	0.000	0.000	0.955
Lights	0	278	32	0	310	0	0	24	0	8	0	32	0	0	3	169	0	0	172	0	0	1	1	0	0	2	0	0	516
% Lights	0.0%	94.6%	82.1%	0.0%	93.1%	0.0%	0.0%	75.0%	0.0%	72.7%	0.0%	69.6%	0.0%	0.0%	100.0%	89.0%	0.0%	0.0%	78.5%	0.0%	0.0%	100.0%	100.0%	0.0%	0.0%	100.0%	0.0%	0.0%	86.0%
Trucks	0	0	0	0	0	0	0	0	0	0	0	0	0	0	0	0	0	0	0	0	0	0	0	0	0	0	0	0	0
% Trucks	0.0%	0.0%	0.0%	0.0%	0.0%	0.0%	0.0%	0.0%	0.0%	0.0%	0.0%	0.0%	0.0%	0.0%	0.0%	0.0%	0.0%	0.0%	0.0%	0.0%	0.0%	0.0%	0.0%	0.0%	0.0%	0.0%	0.0%	0.0%	0.0%
Buses	0	16	7	0	23	0	0	8	0	3	0	11	0	0	0	19	0	0	19	0	0	0	0	0	0	0	0	0	53
% Buses	0.0%	5.4%	17.9%	0.0%	0.0%	0.0%	0.0%	25.0%	0.0%	27.3%	0.0%	0.0%	0.0%	0.0%	0.0%	10.1%	0.0%	0.0%	0.0%	0.0%	0.0%	0.0%	0.0%	0.0%	0.0%	0.0%	0.0%	0.0%	8.8%
Pedestrians	0	0	0	0	0	3	2	0	0	0	0	0	25	3	0	0	0	1	0	0	0	0	0	0	0	0	4	4	0
% Pedestrians	0.0%	0.0%	0.0%	0.0%	0.0%	100.0%	66.7%	0.0%	0.0%	0.0%	0.0%	0.0%	100.0%	100.0%	0.0%	0.0%	0.0%	0.0%	0.0%	0.0%	0.0%	0.0%	0.0%	0.0%	0.0%	0.0%	100.0%	80.0%	0.0%
Bicycles on Crosswalk	0	0	0	0	0	0	1	0	0	0	0	0	0	0	0	0	0	0	0	0	0	0	0	0	0	0	0	1	0
% Bicycles on Crosswalk	0.0%	0.0%	0.0%	0.0%	0.0%	0.0%	33.3%	0.0%	0.0%	0.0%	0.0%	0.0%	0.0%	0.0%	0.0%	0.0%	0.0%	0.0%	0.0%	0.0%	0.0%	0.0%	0.0%	0.0%	0.0%	0.0%	0.0%	20.0%	0.0%

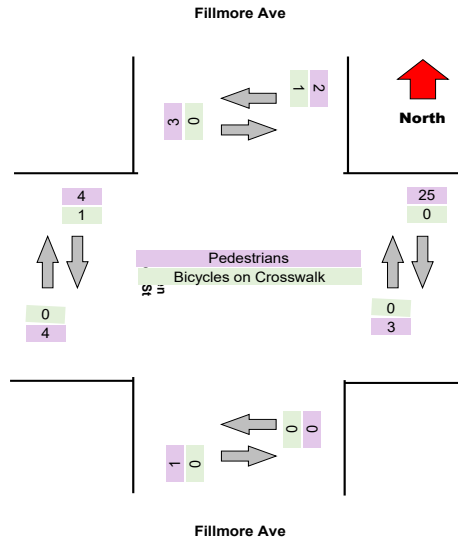
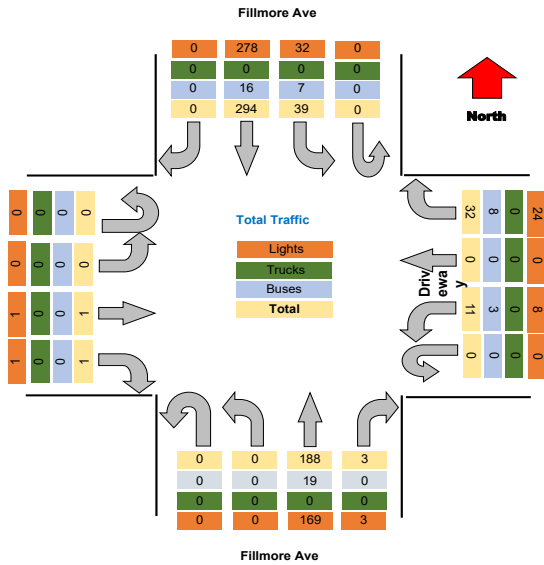

**Turning Movement Peak Hour Data (PM)**

4:45:00 PM

Leg Direction	Fillmore Ave				French St				Fillmore Ave				Driveway				Total													
	Southbound		Northbound		Westbound		Eastbound		Northbound		Eastbound		Right		Left															
Start Time	Right	Thru	Left	U-Turn	App Total	Peds CW	Peds CCW	Right	Thru	Left	U-Turn	App Total	Peds CW	Peds CCW	Right	Thru	Left	U-Turn	App Total	Peds CW	Peds CCW									
4:45:00 PM	2	88	25	0	115	2	3	11	0	0	0	11	0	0	5	89	4	0	98	1	2	8	1	3	0	12	4	3	236	
5:00:00 PM	4	78	22	0	104	3	4	15	0	3	0	18	3	1	3	87	5	0	95	1	1	2	0	0	0	2	5	7	219	
5:15:00 PM	3	80	11	0	94	1	1	19	0	1	0	20	0	1	2	78	6	0	86	0	0	2	1	2	0	5	0	1	205	
5:30:00 PM	1	70	13	0	84	0	0	9	0	7	0	16	0	0	1	68	1	0	70	0	0	3	0	2	0	5	5	2	175	
<b>Grand Total</b>	<b>10</b>	<b>316</b>	<b>71</b>	<b>0</b>	<b>397</b>	<b>6</b>	<b>8</b>	<b>54</b>	<b>0</b>	<b>11</b>	<b>0</b>	<b>65</b>	<b>3</b>	<b>2</b>	<b>11</b>	<b>322</b>	<b>16</b>	<b>0</b>	<b>349</b>	<b>3</b>	<b>3</b>	<b>15</b>	<b>2</b>	<b>7</b>	<b>0</b>	<b>24</b>	<b>14</b>	<b>13</b>	<b>835</b>	
% Approach	2.5%	79.6%	17.9%	0.0%	0.0%	0.0%	0.0%	83.1%	0.0%	16.9%	0.0%	0.0%	0.0%	0.0%	3.2%	92.3%	4.6%	0.0%	0.0%	0.0%	0.0%	62.5%	8.3%	29.2%	0.0%	0.0%	0.0%	0.0%	0.0%	0.0%
% Total	1.2%	37.8%	8.5%	0.0%	47.5%	0.0%	0.0%	6.5%	0.0%	1.3%	0.0%	7.8%	0.0%	0.0%	1.3%	38.6%	1.9%	0.0%	41.8%	0.0%	0.0%	1.8%	0.2%	0.8%	0.0%	2.9%	0.0%	0.0%	0.0%	
PHF	0.625	0.898	0.710	0.000	0.863	0.000	0.000	0.711	0.000	0.393	0.000	0.813	0.000	0.000	0.550	0.904	0.667	0.000	0.890	0.000	0.000	0.469	0.500	0.583	0.000	0.500	0.000	0.000	0.885	
Lights	10	305	66	0	381	0	0	50	0	11	0	61	0	0	10	314	16	0	340	0	0	15	2	7	0	24	0	0	806	
% Lights	100.0%	96.5%	93.0%	0.0%	96.0%	0.0%	0.0%	92.6%	0.0%	100.0%	0.0%	93.8%	0.0%	0.0%	80.9%	97.6%	100.0%	0.0%	97.4%	0.0%	0.0%	100.0%	100.0%	100.0%	0.0%	100.0%	0.0%	0.0%	96.5%	
Trucks	0	2	0	0	2	0	0	0	0	0	0	0	0	0	0	1	0	0	1	0	0	0	0	0	0	0	0	0	3	
% Trucks	0.0%	0.6%	0.0%	0.0%	0.5%	0.0%	0.0%	0.0%	0.0%	0.0%	0.0%	0.0%	0.0%	0.0%	0.0%	0.3%	0.0%	0.0%	0.3%	0.0%	0.0%	0.0%	0.0%	0.0%	0.0%	0.0%	0.0%	0.0%	0.4%	
Buses	0	9	5	0	14	0	0	4	0	0	0	4	0	0	1	7	0	0	8	0	0	0	0	0	0	0	0	0	26	
% Buses	0.0%	2.8%	7.0%	0.0%	0.0%	0.0%	0.0%	7.4%	0.0%	0.0%	0.0%	0.0%	0.0%	0.0%	9.1%	2.2%	0.0%	0.0%	0.0%	0.0%	0.0%	0.0%	0.0%	0.0%	0.0%	0.0%	0.0%	0.0%	3.1%	
Pedestrians	0	0	0	0	0	6	5	0	0	0	0	9	2	0	0	0	0	0	0	0	3	0	0	0	0	0	14	13	0	
% Pedestrians	0.0%	0.0%	0.0%	0.0%	0.0%	100.0%	100.0%	0.0%	0.0%	0.0%	0.0%	0.0%	100.0%	100.0%	0.0%	0.0%	0.0%	0.0%	0.0%	0.0%	100.0%	100.0%	0.0%	0.0%	0.0%	0.0%	0.0%	100.0%	100.0%	0.0%
Bicycles on Crosswalk	0	0	0	0	0	0	0	0	0	0	0	0	0	0	0	0	0	0	0	0	0	0	0	0	0	0	0	0	0	
% Bicycles on Crosswalk	0.0%	0.0%	0.0%	0.0%	0.0%	0.0%	0.0%	0.0%	0.0%	0.0%	0.0%	0.0%	0.0%	0.0%	0.0%	0.0%	0.0%	0.0%	0.0%	0.0%	0.0%	0.0%	0.0%	0.0%	0.0%	0.0%	0.0%	0.0%	0.0%	

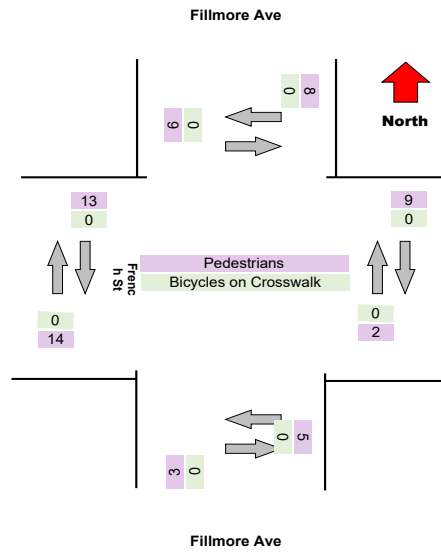
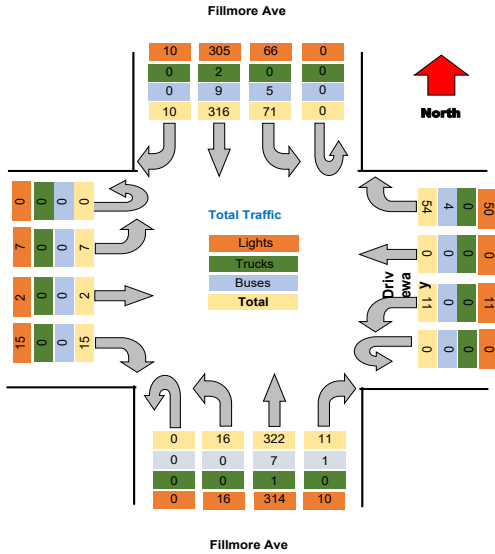



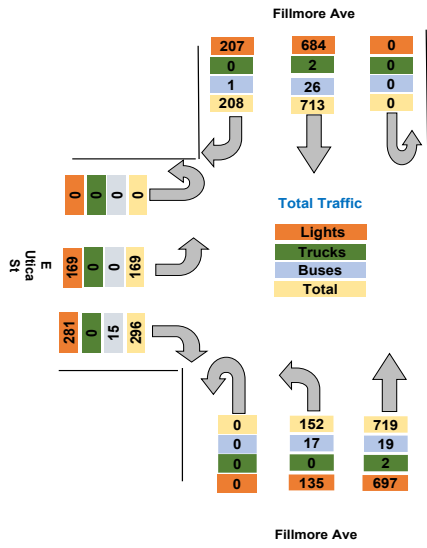

Turning Movement Data Plot

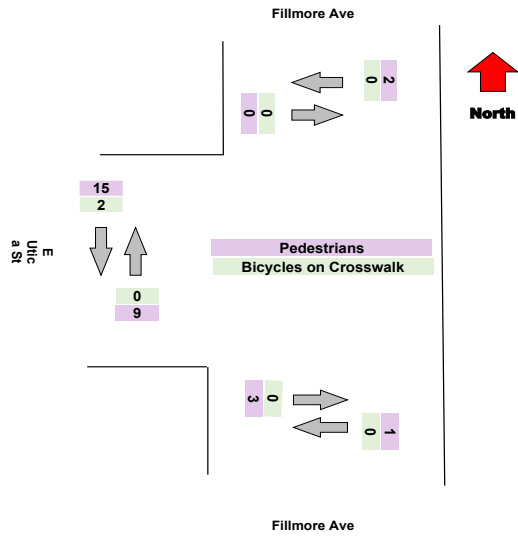

Turning Movement Peak Hour Data (AM)

7:30:00 AM

Leg Direction	Fillmore Ave Southbound						Fillmore Ave NorthBound						E Utica St Eastbound				
	Right	Thru	U-Turn	App Total	Peds CW	Peds CCW	Thru	Left	U-Turn	App Total	Peds CW	Peds CCW	Right	Left	U-Turn	App Total	Peds CW
7:30:00 AM	10	26	0	36	0	0	33	9	0	42	0	0	12	1	0	13	1
7:45:00 AM	9	38	0	47	0	0	30	6	0	36	0	0	18	5	0	23	0
8:00:00 AM	6	38	0	44	0	0	26	7	0	33	0	0	24	9	0	33	1
8:15:00 AM	7	41	0	48	0	0	33	4	0	37	0	0	12	4	0	16	0
<b>Grand Total</b>	<b>32</b>	<b>143</b>	<b>0</b>	<b>175</b>	<b>0</b>	<b>0</b>	<b>122</b>	<b>26</b>	<b>0</b>	<b>148</b>	<b>0</b>	<b>0</b>	<b>66</b>	<b>19</b>	<b>0</b>	<b>85</b>	<b>2</b>
% Approach	18.3%	81.7%	0.0%	0.0%	0.0%	0.0%	82.4%	17.6%	0.0%	0.0%	0.0%	0.0%	77.6%	22.4%	0.0%	0.0%	0.0%
% Total	7.8%	35.0%	0.0%	42.9%	0.0%	0.0%	29.9%	6.4%	0.0%	36.3%	0.0%	0.0%	16.2%	4.7%	0.0%	20.8%	0.0%
PHF	0.800	0.872	0.000	0.911	0.000	0.000	0.924	0.722	0.000	0.881	0.000	0.000	0.688	0.528	0.000	0.644	0.000
Lights	32	135	0	167	0	0	115	20	0	135	0	0	62	19	0	81	0
% Lights	100.0%	94.4%	0.0%	95.4%	0.0%	0.0%	94.3%	76.9%	0.0%	91.2%	0.0%	0.0%	93.9%	100.0%	0.0%	95.3%	0.0%
Trucks	0	0	0	0	0	0	0	0	0	0	0	0	0	0	0	0	0
% Trucks	0.0%	0.0%	0.0%	0.0%	0.0%	0.0%	0.0%	0.0%	0.0%	0.0%	0.0%	0.0%	0.0%	0.0%	0.0%	0.0%	0.0%
Buses	0	8	0	8	0	0	7	6	0	13	0	0	4	0	0	4	0
% Buses	0.0%	5.6%	0.0%	0.0%	0.0%	0.0%	5.7%	23.1%	0.0%	0.0%	0.0%	0.0%	6.1%	0.0%	0.0%	0.0%	0.0%
Pedestrians	0	0	0	0	0	0	0	0	0	0	0	0	0	0	0	0	2
% Pedestrians	0.0%	0.0%	0.0%	0.0%	0.0%	0.0%	0.0%	0.0%	0.0%	0.0%	0.0%	0.0%	0.0%	0.0%	0.0%	0.0%	100.0%
Bicycles on Crosswalk	0	0	0	0	0	0	0	0	0	0	0	0	0	0	0	0	0
% Bicycles on Crosswalk	0.0%	0.0%	0.0%	0.0%	0.0%	0.0%	0.0%	0.0%	0.0%	0.0%	0.0%	0.0%	0.0%	0.0%	0.0%	0.0%	0.0%

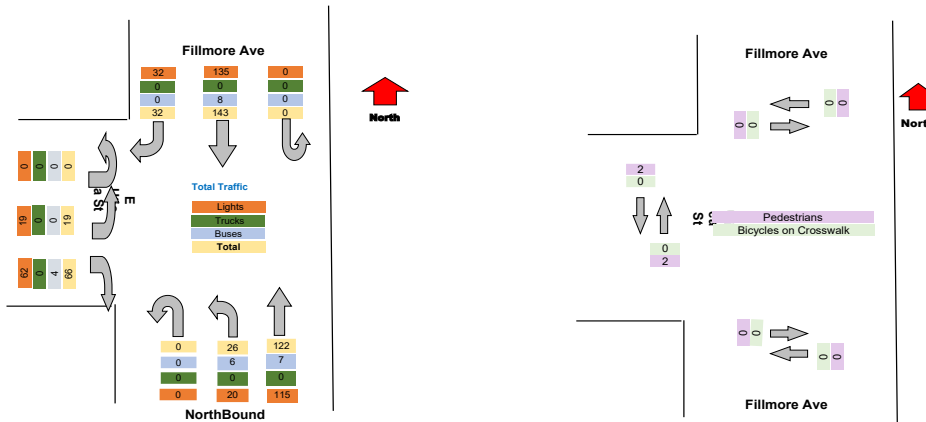



Turning Movement Peak Hour Data (PM)

4:30:00 PM

Leg Direction	Fillmore Ave Southbound						Fillmore Ave NorthBound						E Utica St Eastbound					
	Right	Thru	U-Turn	App Total	Peds CW	Peds CCW	Thru	Left	U-Turn	App Total	Peds CW	Peds CCW	Right	Left	U-Turn	App Total	Peds CW	
4:30:00 PM	19	58	0	77	0	0	64	13	0	77	0	0	14	10	0	24	0	
4:45:00 PM	20	56	0	76	0	0	74	12	0	86	0	1	25	13	0	38	1	
5:00:00 PM	25	74	0	99	0	1	68	11	0	79	1	0	23	15	0	38	0	
5:15:00 PM	18	52	0	70	0	0	76	15	0	91	0	0	30	18	0	48	0	
<b>Grand Total</b>	<b>82</b>	<b>240</b>	<b>0</b>	<b>322</b>	<b>0</b>	<b>1</b>	<b>282</b>	<b>51</b>	<b>0</b>	<b>333</b>	<b>1</b>	<b>1</b>	<b>92</b>	<b>56</b>	<b>0</b>	<b>148</b>	<b>1</b>	
% Approach	25.5%	74.5%	0.0%	0.0%	0.0%	0.0%	84.7%	15.3%	0.0%	0.0%	0.0%	0.0%	62.2%	37.8%	0.0%	0.0%	0.0%	
% Total	10.2%	29.9%	0.0%	40.1%	0.0%	0.0%	35.1%	6.4%	0.0%	41.5%	0.0%	0.0%	11.5%	7.0%	0.0%	18.4%	0.0%	
PHF	0.820	0.811	0.000	0.813	0.000	0.000	0.928	0.850	0.000	0.915	0.000	0.000	0.767	0.778	0.000	0.771	0.000	
Lights	81	229	0	310	0	0	276	48	0	324	0	0	88	56	0	144	0	
% Lights	98.8%	95.4%	0.0%	96.3%	0.0%	0.0%	97.9%	94.1%	0.0%	97.3%	0.0%	0.0%	95.7%	100.0%	0.0%	97.3%	0.0%	
Trucks	0	2	0	2	0	0	2	0	0	2	0	0	0	0	0	0	0	
% Trucks	0.0%	0.8%	0.0%	0.6%	0.0%	0.0%	0.7%	0.0%	0.0%	0.6%	0.0%	0.0%	0.0%	0.0%	0.0%	0.0%	0.0%	
Buses	1	8	0	9	0	0	3	3	0	6	0	0	4	0	0	4	0	
% Buses	1.2%	3.3%	0.0%	0.0%	0.0%	0.0%	1.1%	5.9%	0.0%	0.0%	0.0%	0.0%	4.3%	0.0%	0.0%	0.0%	0.0%	
Pedestrians	0	0	0	0	0	1	0	0	0	1	1	1	0	0	0	0	1	
% Pedestrians	0.0%	0.0%	0.0%	0.0%	0.0%	100.0%	0.0%	0.0%	0.0%	0.0%	100.0%	100.0%	0.0%	0.0%	0.0%	0.0%	100.0%	
Bicycles on Crosswalk	0	0	0	0	0	0	0	0	0	0	0	0	0	0	0	0	0	
% Bicycles on Crosswalk	0.0%	0.0%	0.0%	0.0%	0.0%	0.0%	0.0%	0.0%	0.0%	0.0%	0.0%	0.0%	0.0%	0.0%	0.0%	0.0%	0.0%	

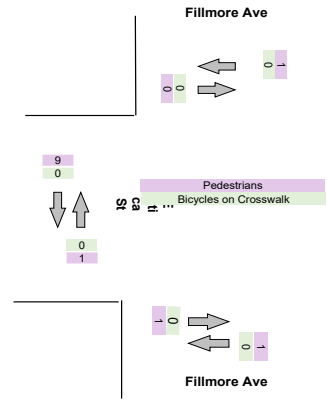
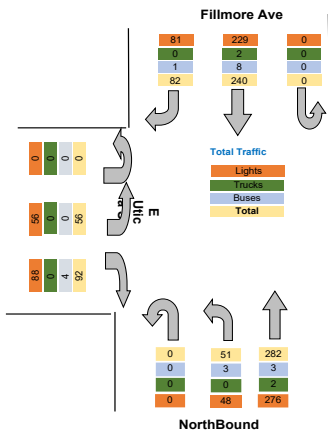

Intersection: Elm St Pine St  
 Location: Kennett Square, PA  
 Site: 01  
 Survey Date: Wednesday, 04-28-2021  
 GPS: 42.948550, -72.790034



Peds CCW	Total
0	61
0	71
0	132
0	77
0	82
0	91
0	106
0	356
2	110
0	101
2	211
3	205
1	196
1	178
4	200
9	779
0	216
4	209
1	185
1	170
6	780
17	2258
0.0%	0.0%
0.0%	0.0%
0	2173
0.0%	96.2%
0	4
0.0%	0.2%
0	76
0.0%	3.5%
15	0
88.2%	0.0%
2	0
11.8%	0.0%

Intersection: Elm St Pine St  
 Location: Kennett Square, PA  
 Site: 01  
 Survey Date: Wednesday, 04-28-2021  
 GPS: 42.948550, -72.790034



Peds CCW	Total
0	91
0	106
2	110
0	101
2	408
0.0%	
0.0%	
0.000	0.927
0	383
0.0%	93.9%
0	0
0.0%	0.0%
0	25
0.0%	6.1%
2	0
100.0%	0.0%
0	0
0.0%	0.0%

Intersection: Elm St Pine St  
 Location: Kennett Square, PA  
 Site: 01  
 Survey Date: Wednesday, 04-28-2021  
 GPS: 42.948550, -72.790034



Peds CCW	Total
1	178
4	200
0	216
4	209
9	803
0.0%	
0.0%	
0.000	0.929
0	778
0.0%	96.9%
0	4
0.0%	0.5%
0	19
0.0%	2.4%
9	0
100.0%	0.0%
0	0
0.0%	0.0%

Project	LaBella
Project Code	LaBella
Site Name	23
Legs and Movements	All Processed Legs & Movements
Bin Size	15 minutes
Survey Date	2021-11-03, Wednesday
Location	23
Latitude and Longitude	42.910946, -78.839079

	Start	End	PHF
Forced Peak AM	2021/11/03 07:30:00	2021/11/03 08:30:00	0.843
Forced Peak PM	2021/11/03 16:30:00	2021/11/03 17:30:00	0.904
AM Peak	2021/11/03 07:30:00	2021/11/03 08:30:00	0.843
PM Peak	2021/11/03 16:30:00	2021/11/03 17:30:00	0.904

Turning Movement Data

Leg Direction	Fillmore Ave Southbound					Fillmore Ave NorthBound					E Utica St Eastbound				
	Right	Thru	U-Turn	App Total	Peds CW Peds CCW	Thru	Left	U-Turn	App Total	Peds CW Peds CCW	Right	Left	U-Turn	App Total	Peds CW
Start Time															
6:30:00 AM	9	22	0	31	0 0	21	3	0	24	0 0	8	3	0	11	0
6:45:00 AM	6	26	0	32	0 0	31	5	0	36	0 0	15	6	0	21	0
<b>Hourly Total</b>	<b>15</b>	<b>48</b>	<b>0</b>	<b>63</b>	<b>0 0</b>	<b>52</b>	<b>8</b>	<b>0</b>	<b>60</b>	<b>0 0</b>	<b>23</b>	<b>9</b>	<b>0</b>	<b>32</b>	<b>0</b>
7:00:00 AM	9	31	0	40	0 0	26	9	0	35	0 0	15	9	0	24	3
7:15:00 AM	8	39	0	47	0 0	30	6	0	36	0 0	10	5	0	15	0
7:30:00 AM	18	48	0	66	0 0	36	6	0	42	0 0	19	8	0	27	2
7:45:00 AM	18	74	0	92	1 1	59	13	0	73	1 0	22	9	0	32	1
<b>Hourly Total</b>	<b>53</b>	<b>192</b>	<b>0</b>	<b>245</b>	<b>1 1</b>	<b>151</b>	<b>34</b>	<b>0</b>	<b>186</b>	<b>1 0</b>	<b>66</b>	<b>31</b>	<b>0</b>	<b>98</b>	<b>6</b>
8:00:00 AM	20	58	0	78	0 0	48	8	0	56	0 0	20	13	0	33	0
8:15:00 AM	13	64	0	77	0 0	52	9	0	61	2 0	13	12	0	27	0
<b>Hourly Total</b>	<b>33</b>	<b>122</b>	<b>0</b>	<b>155</b>	<b>0 0</b>	<b>100</b>	<b>17</b>	<b>0</b>	<b>117</b>	<b>2 0</b>	<b>33</b>	<b>25</b>	<b>0</b>	<b>60</b>	<b>0</b>
4:00:00 PM	19	63	0	82	0 0	68	14	0	82	1 2	27	27	0	54	11
4:15:00 PM	21	80	0	101	1 0	74	20	0	94	0 0	23	25	0	48	1
4:30:00 PM	19	85	0	104	0 0	57	16	0	73	0 0	42	26	0	68	6
4:45:00 PM	13	70	0	83	0 1	79	18	0	97	0 0	23	30	0	53	3
<b>Hourly Total</b>	<b>72</b>	<b>298</b>	<b>0</b>	<b>370</b>	<b>1 1</b>	<b>278</b>	<b>68</b>	<b>0</b>	<b>346</b>	<b>1 2</b>	<b>115</b>	<b>108</b>	<b>0</b>	<b>223</b>	<b>21</b>
5:00:00 PM	14	65	0	79	0 0	71	4	0	75	0 2	23	17	0	40	1
5:15:00 PM	8	72	0	80	0 0	69	11	0	80	1 0	35	19	0	54	2
5:30:00 PM	23	62	0	85	1 0	72	16	0	88	0 0	23	12	0	35	3
5:45:00 PM	10	53	0	63	0 0	55	11	0	66	0 0	26	10	0	36	1
<b>Hourly Total</b>	<b>55</b>	<b>252</b>	<b>0</b>	<b>307</b>	<b>1 0</b>	<b>267</b>	<b>42</b>	<b>0</b>	<b>309</b>	<b>1 2</b>	<b>107</b>	<b>58</b>	<b>0</b>	<b>165</b>	<b>7</b>
<b>Grand Total</b>	<b>228</b>	<b>912</b>	<b>0</b>	<b>1140</b>	<b>3 2</b>	<b>848</b>	<b>169</b>	<b>0</b>	<b>1018</b>	<b>5 4</b>	<b>344</b>	<b>231</b>	<b>0</b>	<b>578</b>	<b>34</b>
% Approach	20.0%	80.0%	0.0%	0.0%	0.0%	83.3%	16.6%	0.0%	0.0%	0.0%	59.5%	40.0%	0.0%	0.0%	0.0%
% Total	8.3%	33.3%	0.0%	41.7%	0.0%	31.0%	6.2%	0.0%	37.2%	0.0%	12.6%	8.4%	0.0%	21.1%	0.0%
Lights	223	847	0	1070	0 0	786	147	0	933	0 0	314	221	0	535	0
% Lights	97.8%	92.9%	0.0%	93.9%	0.0%	92.7%	87.0%	0.0%	91.7%	0.0%	91.3%	95.7%	0.0%	92.6%	0.0%
Trucks	0	2	0	2	0 0	2	0	0	2	0 0	1	0	0	1	0
% Trucks	0.0%	0.2%	0.0%	0.2%	0.0%	0.2%	0.0%	0.0%	0.2%	0.0%	0.3%	0.0%	0.0%	0.2%	0.0%
Buses	5	63	0	68	0 0	60	22	0	82	0 0	29	10	0	39	0
% Buses	2.2%	6.9%	0.0%	0.0%	0.0%	0.0%	13.0%	0.0%	0.0%	0.0%	8.4%	4.3%	0.0%	0.0%	0.0%
Pedestrians	0	0	0	0	3 2	0	0	0	0	5 4	0	0	0	0	34
% Pedestrians	0.0%	0.0%	0.0%	0.0%	100.0%	0.0%	0.0%	0.0%	0.0%	100.0%	0.0%	0.0%	0.0%	0.0%	100.0%
Bicycles on Crosswalk	0	0	0	0	0 0	0	0	0	0	0 0	0	0	0	0	0
% Bicycles on Crosswalk	0.0%	0.0%	0.0%	0.0%	0.0%	0.0%	0.0%	0.0%	0.0%	0.0%	0.0%	0.0%	0.0%	0.0%	0.0%

Turning Movement Data Plot

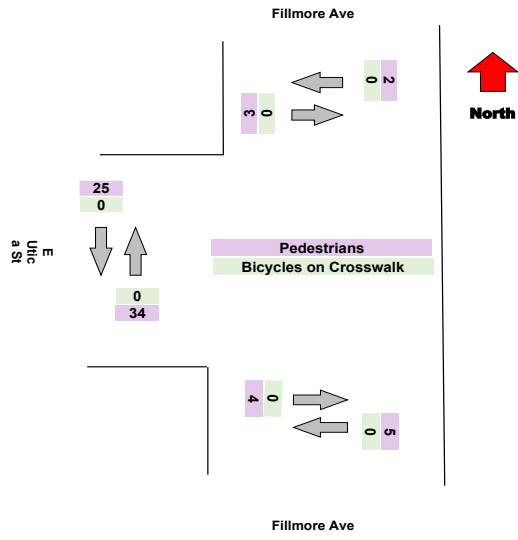
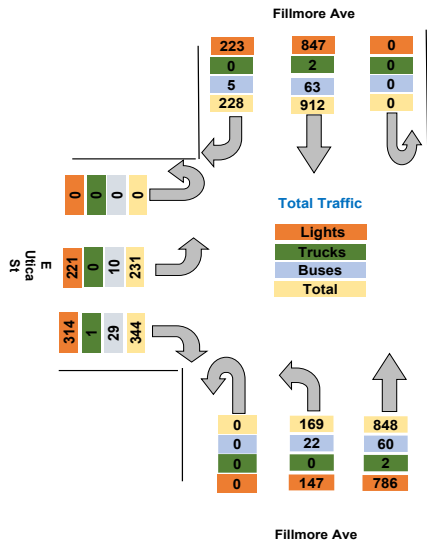

Turning Movement Peak Hour Data (AM)

7:30:00 AM

Leg Direction	Fillmore Ave Southbound						Fillmore Ave NorthBound						E Utica St Eastbound				
	Right	Thru	U-Turn	App Total	Peds CW	Peds CCW	Thru	Left	U-Turn	App Total	Peds CW	Peds CCW	Right	Left	U-Turn	App Total	Peds CW
7:30:00 AM	18	48	0	66	0	0	36	6	0	42	0	0	19	8	0	27	2
7:45:00 AM	18	74	0	92	1	1	59	13	0	73	1	0	22	9	0	32	1
8:00:00 AM	20	58	0	78	0	0	48	8	0	56	0	0	20	13	0	33	0
8:15:00 AM	13	64	0	77	0	0	52	9	0	61	2	0	13	12	0	27	0
<b>Grand Total</b>	69	244	0	313	1	1	195	36	0	232	3	0	74	42	0	119	3
% Approach	22.0%	78.0%	0.0%	0.0%	0.0%	0.0%	84.1%	15.5%	0.0%	0.0%	0.0%	0.0%	62.2%	35.3%	0.0%	0.0%	0.0%
% Total	10.4%	36.7%	0.0%	47.1%	0.0%	0.0%	29.4%	5.4%	0.0%	34.9%	0.0%	0.0%	11.1%	6.3%	0.0%	17.9%	0.0%
PHF	0.863	0.824	0.000	0.851	0.000	0.000	0.826	0.692	0.000	0.795	0.000	0.000	0.841	0.808	0.000	0.902	0.000
Lights	66	226	0	292	0	0	171	28	0	199	0	0	69	39	0	108	0
% Lights	95.7%	92.6%	0.0%	93.3%	0.0%	0.0%	87.7%	77.8%	0.0%	85.8%	0.0%	0.0%	93.2%	92.9%	0.0%	90.8%	0.0%
Trucks	0	0	0	0	0	0	0	0	0	0	0	0	0	0	0	0	0
% Trucks	0.0%	0.0%	0.0%	0.0%	0.0%	0.0%	0.0%	0.0%	0.0%	0.0%	0.0%	0.0%	0.0%	0.0%	0.0%	0.0%	0.0%
Buses	3	18	0	21	0	0	24	8	0	32	0	0	5	3	0	8	0
% Buses	4.3%	7.4%	0.0%	0.0%	0.0%	0.0%	12.3%	22.2%	0.0%	0.0%	0.0%	0.0%	6.8%	7.1%	0.0%	0.0%	0.0%
Pedestrians	0	0	0	0	1	1	0	0	0	3	0	0	0	0	0	3	0
% Pedestrians	0.0%	0.0%	0.0%	0.0%	100.0%	100.0%	0.0%	0.0%	0.0%	0.0%	100.0%	0.0%	0.0%	0.0%	0.0%	0.0%	100.0%
Bicycles on Crosswalk	0	0	0	0	0	0	0	0	0	0	0	0	0	0	0	0	0
% Bicycles on Crosswalk	0.0%	0.0%	0.0%	0.0%	0.0%	0.0%	0.0%	0.0%	0.0%	0.0%	0.0%	0.0%	0.0%	0.0%	0.0%	0.0%	0.0%

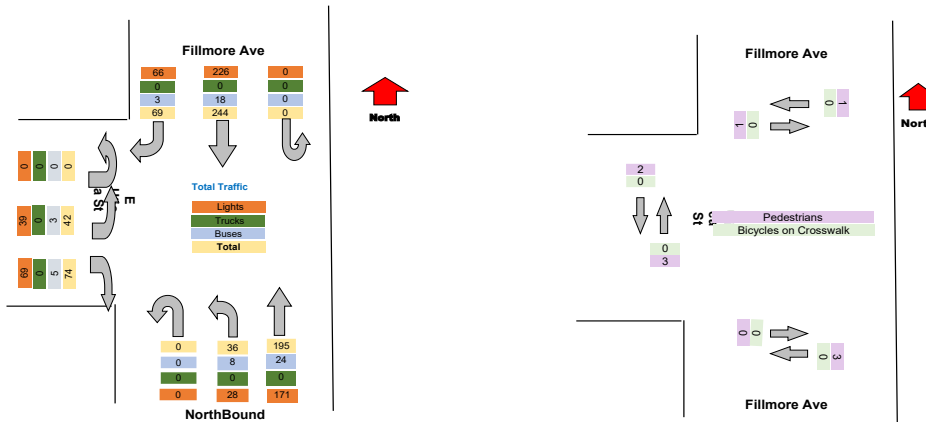

Turning Movement Peak Hour Data (PM)

4:30:00 PM

Leg Direction	Fillmore Ave Southbound						Fillmore Ave NorthBound						E Utica St Eastbound				
	Right	Thru	U-Turn	App Total	Peds CW	Peds CCW	Thru	Left	U-Turn	App Total	Peds CW	Peds CCW	Right	Left	U-Turn	App Total	Peds CW
4:30:00 PM	19	85	0	104	0	0	57	16	0	73	0	0	42	26	0	68	6
4:45:00 PM	13	70	0	83	0	1	79	18	0	97	0	0	23	30	0	53	3
5:00:00 PM	14	65	0	79	0	0	71	4	0	75	0	2	23	17	0	40	1
5:15:00 PM	8	72	0	80	0	0	69	11	0	80	1	0	35	19	0	54	2
<b>Grand Total</b>	54	292	0	346	0	1	276	49	0	325	1	2	123	92	0	215	12
% Approach	15.6%	84.4%	0.0%	0.0%	0.0%	0.0%	84.9%	15.1%	0.0%	0.0%	0.0%	0.0%	57.2%	42.8%	0.0%	0.0%	0.0%
% Total	6.1%	33.0%	0.0%	39.1%	0.0%	0.0%	31.2%	5.5%	0.0%	36.7%	0.0%	0.0%	13.9%	10.4%	0.0%	24.3%	0.0%
PHF	0.711	0.859	0.000	0.832	0.000	0.000	0.873	0.681	0.000	0.838	0.000	0.000	0.732	0.767	0.000	0.790	0.000
Lights	52	276	0	328	0	0	264	45	0	309	0	0	114	91	0	205	0
% Lights	96.3%	94.5%	0.0%	94.8%	0.0%	0.0%	95.7%	91.8%	0.0%	95.1%	0.0%	0.0%	92.7%	98.9%	0.0%	95.3%	0.0%
Trucks	0	1	0	1	0	0	1	0	0	1	0	0	0	0	0	0	0
% Trucks	0.0%	0.3%	0.0%	0.3%	0.0%	0.0%	0.4%	0.0%	0.0%	0.3%	0.0%	0.0%	0.0%	0.0%	0.0%	0.0%	0.0%
Buses	2	15	0	17	0	0	11	4	0	15	0	0	9	1	0	10	0
% Buses	3.7%	5.1%	0.0%	0.0%	0.0%	0.0%	4.0%	8.2%	0.0%	0.0%	0.0%	0.0%	7.3%	1.1%	0.0%	0.0%	0.0%
Pedestrians	0	0	0	0	0	1	0	0	0	1	2	0	0	0	0	0	12
% Pedestrians	0.0%	0.0%	0.0%	0.0%	0.0%	100.0%	0.0%	0.0%	0.0%	0.0%	100.0%	100.0%	0.0%	0.0%	0.0%	0.0%	100.0%
Bicycles on Crosswalk	0	0	0	0	0	0	0	0	0	0	0	0	0	0	0	0	0
% Bicycles on Crosswalk	0.0%	0.0%	0.0%	0.0%	0.0%	0.0%	0.0%	0.0%	0.0%	0.0%	0.0%	0.0%	0.0%	0.0%	0.0%	0.0%	0.0%

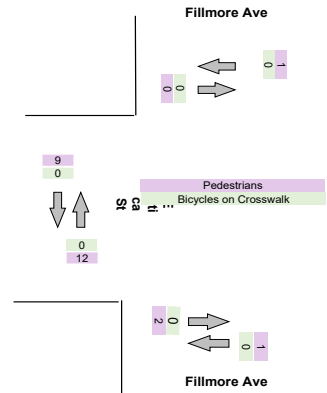
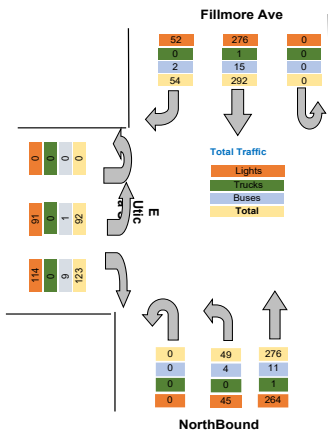



Intersection: Elm St Pine St  
 Location: Kennett Square, PA  
 Site: 01  
 Survey Date: Wednesday, 04-28-2021  
 GPS: 42.948550, -72.790034



Peds CCW	Total
0	66
0	89
0	155
0	99
2	98
1	135
0	197
3	529
0	167
1	165
1	332
5	218
5	243
0	245
4	233
14	939
2	194
3	214
1	208
1	165
7	781
25	2736
0.0%	0.0%
0.0%	0.0%
0	2538
0.0%	92.8%
0	5
0.0%	0.2%
0	169
0.0%	6.9%
25	0
100.0%	0.0%
0	0
0.0%	0.0%

Intersection: Elm St Pine St  
 Location: Kennett Square, PA  
 Site: 01  
 Survey Date: Wednesday, 04-28-2021  
 GPS: 42.948550, -72.790034



Peds CCW	<b>Total</b>
1	<b>135</b>
0	<b>197</b>
0	<b>167</b>
1	<b>165</b>
2	<b>664</b>
0.0%	
0.0%	
0.000	<b>0.843</b>
0	<b>599</b>
0.0%	<b>90.2%</b>
0	<b>0</b>
0.0%	<b>0.0%</b>
0	<b>61</b>
0.0%	<b>9.2%</b>
2	<b>0</b>
100.0%	<b>0.0%</b>
0	<b>0</b>
0.0%	<b>0.0%</b>

Intersection: Elm St Pine St  
 Location: Kennett Square, PA  
 Site: 01  
 Survey Date: Wednesday, 04-28-2021  
 GPS: 42.948550, -72.790034



Peds CCW	Total
0	245
4	233
2	194
3	214
9	886
0.0%	
0.0%	
0.000	0.904
0	842
0.0%	95.0%
0	2
0.0%	0.2%
0	42
0.0%	4.7%
9	0
100.0%	0.0%
0	0
0.0%	0.0%

Project	LaBella
Project Code	LaBella
Site Name	23
Legs and Movements	All Processed Legs & Movements
Bin Size	15 minutes
Survey Date	2021-11-04, Thursday
Location	23
Latitude and Longitude	42.910946, -78.839079

	Start	End	PHF
Forced Peak AM	2021/11/04 07:30:00	2021/11/04 08:30:00	0.921787709
Forced Peak PM	2021/11/04 16:30:00	2021/11/04 17:30:00	0.919960474
AM Peak	2021/11/04 07:30:00	2021/11/04 08:30:00	0.921787709
PM Peak	2021/11/04 16:30:00	2021/11/04 17:30:00	0.919960474

Turning Movement Data

Leg Direction	Fillmore Ave Southbound						Fillmore Ave NorthBound						E Utica St Eastbound			
	Right	Thru	U-Turn	App Total	Peds CW	Peds CCW	Thru	Left	U-Turn	App Total	Peds CW	Peds CCW	Right	Left	U-Turn	App Total
Start Time																
6:30:00 AM	4	19	0	23	0	0	13	6	0	19	0	0	6	1	0	7
6:45:00 AM	11	29	0	40	0	0	25	5	0	30	1	0	8	6	0	15
<b>Hourly Total</b>	15	48	0	63	0	0	38	11	0	49	1	0	14	7	0	22
7:00:00 AM	10	33	0	43	0	0	29	6	0	35	0	0	9	11	0	20
7:15:00 AM	10	28	0	38	0	0	31	5	0	36	0	0	13	9	0	22
7:30:00 AM	14	55	0	69	0	0	33	10	0	43	0	0	20	17	0	37
7:45:00 AM	24	62	0	86	0	0	42	8	0	50	0	0	22	7	0	29
<b>Hourly Total</b>	58	178	0	236	0	0	135	29	0	164	0	0	64	44	0	108
8:00:00 AM	13	74	0	87	0	0	44	11	0	55	0	0	20	17	0	37
8:15:00 AM	11	69	0	80	0	0	56	9	0	65	0	0	14	8	0	22
<b>Hourly Total</b>	24	143	0	167	0	0	100	20	0	120	0	0	34	25	0	59
4:00:00 PM	19	72	0	91	0	0	79	14	0	93	1	0	23	19	0	42
4:15:00 PM	22	79	0	101	0	0	57	16	0	73	2	0	30	25	0	55
4:30:00 PM	18	59	0	77	0	0	88	10	0	98	0	0	24	20	0	44
4:45:00 PM	15	81	0	96	0	1	82	18	0	100	1	0	30	27	0	57
<b>Hourly Total</b>	74	291	0	365	0	1	306	58	0	364	4	0	107	91	0	198
5:00:00 PM	15	66	0	81	0	0	79	16	1	96	0	3	35	19	0	54
5:15:00 PM	10	73	0	83	0	0	79	21	0	100	1	1	23	22	0	45
5:30:00 PM	15	67	0	82	0	0	72	12	0	84	0	0	24	13	0	37
5:45:00 PM	15	75	0	90	0	0	56	23	0	79	0	0	21	10	0	31
<b>Hourly Total</b>	55	281	0	336	0	0	286	72	1	359	1	4	103	64	0	167
<b>Grand Total</b>	226	941	0	1167	0	1	865	190	1	1056	6	4	322	231	0	554
% Approach	19.4%	80.6%	0.0%	0.0%	0.0%	0.0%	81.9%	18.0%	0.1%	0.0%	0.0%	0.0%	58.1%	41.7%	0.0%	0.0%
% Total	8.1%	33.9%	0.0%	42.0%	0.0%	0.0%	31.1%	6.8%	0.0%	38.0%	0.0%	0.0%	11.6%	8.3%	0.0%	19.9%
Lights	220	883	0	1103	0	0	812	169	1	982	0	0	293	221	0	514
% Lights	97.3%	93.8%	0.0%	94.5%	0.0%	0.0%	93.9%	88.9%	100.0%	93.0%	0.0%	0.0%	91.0%	95.7%	0.0%	92.8%
Trucks	0	2	0	2	0	0	1	0	0	1	0	0	0	0	0	0
% Trucks	0.0%	0.2%	0.0%	0.2%	0.0%	0.0%	0.1%	0.0%	0.0%	0.1%	0.0%	0.0%	0.0%	0.0%	0.0%	0.0%
Buses	6	56	0	62	0	0	52	21	0	73	0	0	29	10	0	39
% Buses	2.7%	6.0%	0.0%	0.0%	0.0%	0.0%	0.0%	11.1%	0.0%	0.0%	0.0%	0.0%	9.0%	4.3%	0.0%	0.0%
Pedestrians	0	0	0	0	0	1	0	0	0	0	6	3	0	0	0	0
% Pedestrians	0.0%	0.0%	0.0%	0.0%	0.0%	100.0%	0.0%	0.0%	0.0%	0.0%	100.0%	75.0%	0.0%	0.0%	0.0%	0.0%
Bicycles on Crosswalk	0	0	0	0	0	0	0	0	0	0	0	1	0	0	0	0
% Bicycles on Crosswalk	0.0%	0.0%	0.0%	0.0%	0.0%	0.0%	0.0%	0.0%	0.0%	0.0%	0.0%	25.0%	0.0%	0.0%	0.0%	0.0%

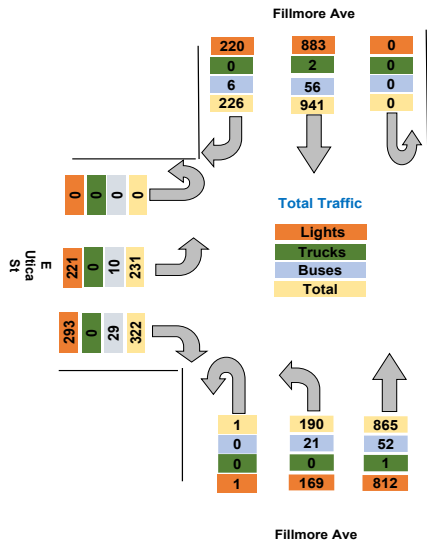

Turning Movement Data Plot

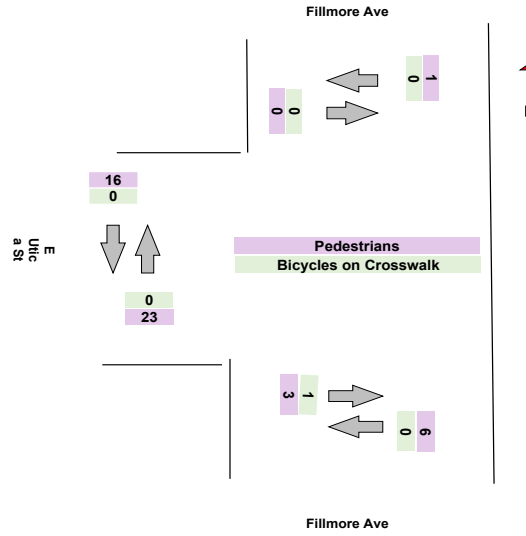

Turning Movement Peak Hour Data (AM)

7:30:00 AM

Leg Direction	Fillmore Ave Southbound						Fillmore Ave NorthBound						E Utica St Eastbound			
	Right	Thru	U-Turn	App Total	Peds CW	Peds CCW	Thru	Left	U-Turn	App Total	Peds CW	Peds CCW	Right	Left	U-Turn	App Total
7:30:00 AM	14	55	0	69	0	0	33	10	0	43	0	0	20	17	0	37
7:45:00 AM	24	62	0	86	0	0	42	8	0	50	0	0	22	7	0	29
8:00:00 AM	13	74	0	87	0	0	44	11	0	55	0	0	20	17	0	37
8:15:00 AM	11	69	0	80	0	0	56	9	0	65	0	0	14	8	0	22
<b>Grand Total</b>	62	260	0	322	0	0	175	38	0	213	0	0	76	49	0	125
% Approach	19.3%	80.7%	0.0%	0.0%	0.0%	0.0%	82.2%	17.8%	0.0%	0.0%	0.0%	0.0%	60.8%	39.2%	0.0%	0.0%
% Total	9.4%	39.4%	0.0%	48.8%	0.0%	0.0%	26.5%	5.8%	0.0%	32.3%	0.0%	0.0%	11.5%	7.4%	0.0%	18.9%
PHF	0.646	0.878	0.000	0.925	0.000	0.000	0.781	0.864	0.000	0.819	0.000	0.000	0.864	0.721	0.000	0.845
Lights	58	244	0	302	0	0	158	30	0	188	0	0	69	45	0	114
% Lights	93.5%	93.8%	0.0%	93.8%	0.0%	0.0%	90.3%	78.9%	0.0%	88.3%	0.0%	0.0%	90.8%	91.8%	0.0%	91.2%
Trucks	0	0	0	0	0	0	0	0	0	0	0	0	0	0	0	0
% Trucks	0.0%	0.0%	0.0%	0.0%	0.0%	0.0%	0.0%	0.0%	0.0%	0.0%	0.0%	0.0%	0.0%	0.0%	0.0%	0.0%
Buses	4	16	0	20	0	0	17	8	0	25	0	0	7	4	0	11
% Buses	6.5%	6.2%	0.0%	0.0%	0.0%	0.0%	9.7%	21.1%	0.0%	0.0%	0.0%	0.0%	9.2%	8.2%	0.0%	0.0%
Pedestrians	0	0	0	0	0	0	0	0	0	0	0	0	0	0	0	0
% Pedestrians	0.0%	0.0%	0.0%	0.0%	0.0%	0.0%	0.0%	0.0%	0.0%	0.0%	0.0%	0.0%	0.0%	0.0%	0.0%	0.0%
Bicycles on Crosswalk	0	0	0	0	0	0	0	0	0	0	0	0	0	0	0	0
% Bicycles on Crosswalk	0.0%	0.0%	0.0%	0.0%	0.0%	0.0%	0.0%	0.0%	0.0%	0.0%	0.0%	0.0%	0.0%	0.0%	0.0%	0.0%

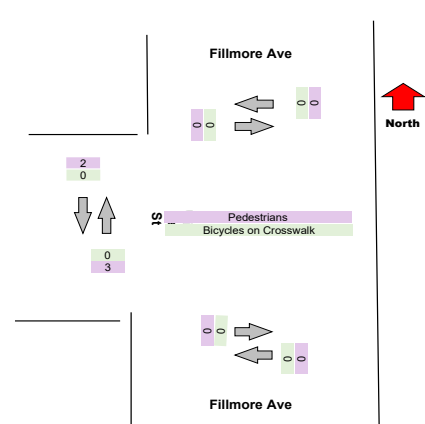
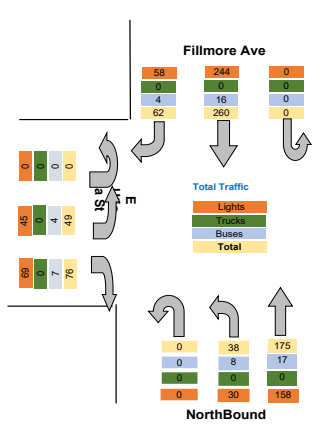

Turning Movement Peak Hour Data (PM)

4:30:00 PM

Leg Direction	Fillmore Ave Southbound						Fillmore Ave NorthBound						E Utica St Eastbound			
	Right	Thru	U-Turn	App Total	Peds CW	Peds CCW	Thru	Left	U-Turn	App Total	Peds CW	Peds CCW	Right	Left	U-Turn	App Total
4:30:00 PM	18	59	0	77	0	0	88	10	0	98	0	0	24	20	0	44
4:45:00 PM	15	81	0	96	0	1	82	18	0	100	1	0	30	27	0	57
5:00:00 PM	15	66	0	81	0	0	79	16	1	96	0	3	35	19	0	54
5:15:00 PM	10	73	0	83	0	0	79	21	0	100	1	1	23	22	0	45
<b>Grand Total</b>	<b>58</b>	<b>279</b>	<b>0</b>	<b>337</b>	<b>0</b>	<b>1</b>	<b>328</b>	<b>65</b>	<b>1</b>	<b>394</b>	<b>2</b>	<b>4</b>	<b>112</b>	<b>88</b>	<b>0</b>	<b>200</b>
% Approach	17.2%	82.8%	0.0%	0.0%	0.0%	0.0%	83.2%	16.5%	0.3%	0.0%	0.0%	0.0%	56.0%	44.0%	0.0%	0.0%
% Total	6.2%	30.0%	0.0%	36.2%	0.0%	0.0%	35.2%	7.0%	0.1%	42.3%	0.0%	0.0%	12.0%	9.5%	0.0%	21.5%
PHF	0.806	0.861	0.000	0.878	0.000	0.000	0.932	0.774	0.250	0.985	0.000	0.000	0.800	0.815	0.000	0.877
Lights	57	265	0	322	0	0	317	62	1	380	0	0	107	88	0	195
% Lights	98.3%	95.0%	0.0%	95.5%	0.0%	0.0%	96.6%	95.4%	100.0%	96.4%	0.0%	0.0%	95.5%	100.0%	0.0%	97.5%
Trucks	0	2	0	2	0	0	1	0	0	1	0	0	0	0	0	0
% Trucks	0.0%	0.7%	0.0%	0.6%	0.0%	0.0%	0.3%	0.0%	0.0%	0.3%	0.0%	0.0%	0.0%	0.0%	0.0%	0.0%
Buses	1	12	0	13	0	0	10	3	0	13	0	0	5	0	0	5
% Buses	1.7%	4.3%	0.0%	0.0%	0.0%	0.0%	3.0%	4.6%	0.0%	0.0%	0.0%	0.0%	4.5%	0.0%	0.0%	0.0%
Pedestrians	0	0	0	0	0	1	0	0	0	0	2	3	0	0	0	0
% Pedestrians	0.0%	0.0%	0.0%	0.0%	0.0%	100.0%	0.0%	0.0%	0.0%	0.0%	100.0%	75.0%	0.0%	0.0%	0.0%	0.0%
Bicycles on Crosswalk	0	0	0	0	0	0	0	0	0	0	0	1	0	0	0	0
% Bicycles on Crosswalk	0.0%	0.0%	0.0%	0.0%	0.0%	0.0%	0.0%	0.0%	0.0%	0.0%	0.0%	25.0%	0.0%	0.0%	0.0%	0.0%

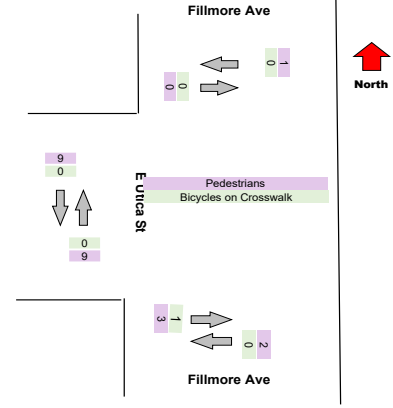
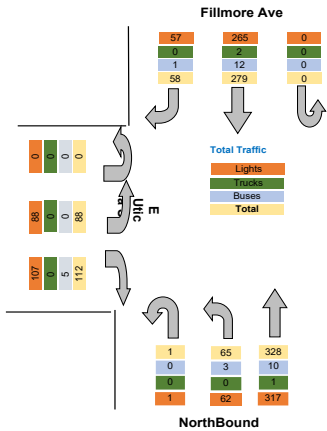

Intersection: Elm St Pine St  
 Location: Kennett Square, PA  
 Site: 01  
 Survey Date: Wednesday, 04-28-2021  
 GPS: 42.948550, -72.790034



Peds CW	Peds CCW	Total
0	0	49
0	0	85
<b>0</b>	<b>0</b>	<b>134</b>
2	0	98
1	0	96
1	2	149
1	0	165
<b>5</b>	<b>2</b>	<b>508</b>
1	0	179
0	0	167
<b>1</b>	<b>0</b>	<b>346</b>
0	2	226
4	1	229
0	2	219
6	0	253
<b>10</b>	<b>5</b>	<b>927</b>
3	4	231
0	3	228
4	1	203
0	1	200
<b>7</b>	<b>9</b>	<b>862</b>
23	16	2777
0.0%	0.0%	0.0%
0.0%	0.0%	0.0%
0	0	2599
0.0%	0.0%	93.6%
0	0	3
0.0%	0.0%	0.1%
0	0	174
0.0%	0.0%	6.3%
23	16	0
100.0%	100.0%	0.0%
0	0	0
0.0%	0.0%	0.0%



Intersection: Elm St Pine St  
 Location: Kennett Square, PA  
 Site: 01  
 Survey Date: Wednesday, 04-28-2021  
 GPS: 42.948550, -72.790034



Peds CW	Peds CCW	Total
1	2	149
1	0	165
1	0	179
0	0	167
3	2	660
0.0%	0.0%	
0.0%	0.0%	
0.000	0.000	0.922
0	0	604
0.0%	0.0%	91.5%
0	0	0
0.0%	0.0%	0.0%
0	0	56
0.0%	0.0%	8.5%
3	2	0
100.0%	100.0%	0.0%
0	0	0
0.0%	0.0%	0.0%

Intersection: Elm St Pine St  
 Location: Kennett Square, PA  
 Site: 01  
 Survey Date: Wednesday, 04-28-2021  
 GPS: 42.948550, -72.790034



Peds CW	Peds CCW	Total
0	2	219
6	0	253
3	4	231
0	3	228
9	9	931
0.0%	0.0%	
0.0%	0.0%	
0.000	0.000	0.920
0	0	897
0.0%	0.0%	96.3%
0	0	3
0.0%	0.0%	0.3%
0	0	31
0.0%	0.0%	3.3%
9	9	0
100.0%	100.0%	0.0%
0	0	0
0.0%	0.0%	0.0%



**Turning Movement Data Plot**

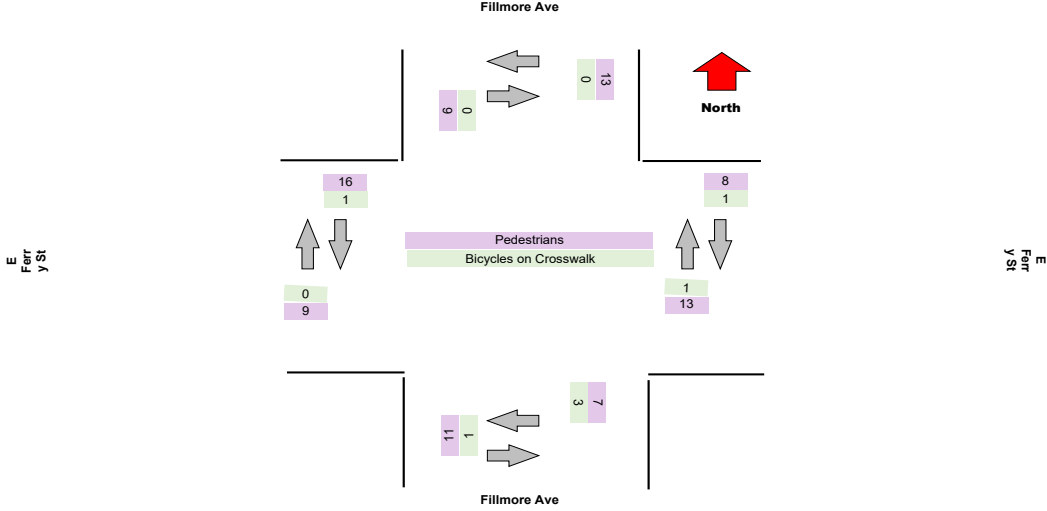
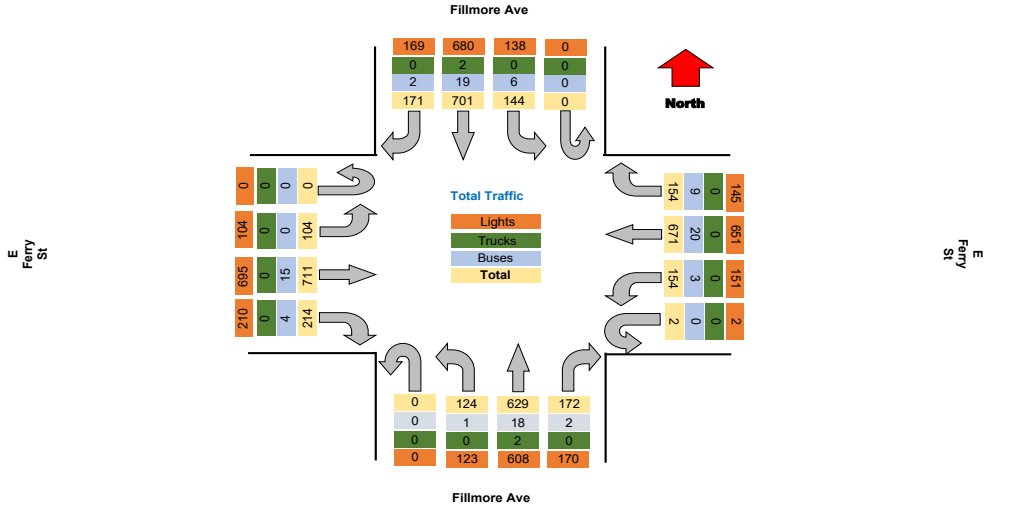

Project : VBH Malta NY  
Site : Site 4  
Location : 42.948550, -73.790036

TSTData.com

Survey Date : 2021-04-28, Wednesday

**Turning Movement Peak Hour Data (AM)**

7:30:00 AM

Leg Direction	Fillmore Ave						E Ferry St						Fillmore Ave						E Ferry St						Total				
	Southbound			Westbound			Northbound			Eastbound			Northbound			Eastbound													
Start Time	Right	Thru	Left	U-Turn	App Total	Peds CW	Peds CCW	Right	Thru	Left	U-Turn	App Total	Peds CW	Peds CCW	Right	Thru	Left	U-Turn	App Total	Peds CW	Peds CCW	Right	Thru	Left	U-Turn	App Total	Peds CW	Peds CCW	
7:30:00 AM	5	29	4	0	38	0	2	6	28	4	0	40	0	0	6	19	5	0	30	0	2	5	34	6	0	45	0	0	153
7:45:00 AM	14	47	8	0	69	0	0	7	36	7	0	50	0	0	5	37	4	0	46	0	0	8	50	7	0	65	0	1	230
8:00:00 AM	7	36	13	0	56	0	1	3	41	7	0	52	1	2	8	28	1	0	40	0	2	12	33	5	0	50	4	5	198
8:15:00 AM	9	39	4	0	52	0	1	7	36	8	0	52	0	1	3	27	7	0	38	0	0	12	32	5	0	49	0	0	191
<b>Grand Total</b>	<b>35</b>	<b>151</b>	<b>29</b>	<b>0</b>	<b>215</b>	<b>0</b>	<b>4</b>	<b>23</b>	<b>141</b>	<b>26</b>	<b>0</b>	<b>194</b>	<b>1</b>	<b>5</b>	<b>22</b>	<b>111</b>	<b>17</b>	<b>0</b>	<b>154</b>	<b>0</b>	<b>4</b>	<b>37</b>	<b>149</b>	<b>23</b>	<b>0</b>	<b>299</b>	<b>4</b>	<b>6</b>	<b>772</b>
<b>% Approach</b>	16.3%	70.2%	13.5%	0.0%	<b>0.0%</b>	0.0%	0.0%	11.9%	72.7%	13.4%	0.0%	<b>0.0%</b>	0.0%	0.0%	14.3%	72.1%	11.0%	0.0%	<b>0.0%</b>	0.0%	0.0%	17.7%	71.3%	11.0%	0.0%	<b>0.0%</b>	0.0%	0.0%	0.0%
<b>% Total</b>	4.5%	19.6%	3.8%	0.0%	<b>27.8%</b>	0.0%	0.0%	3.0%	18.3%	3.4%	0.0%	<b>25.1%</b>	0.0%	0.0%	2.8%	14.4%	2.2%	0.0%	<b>19.9%</b>	0.0%	0.0%	4.8%	19.3%	3.0%	0.0%	<b>27.1%</b>	0.0%	0.0%	0.0%
<b>PHF</b>	0.625	0.803	0.558	0.000	<b>0.779</b>	0.000	0.000	0.821	0.880	0.813	0.000	<b>0.933</b>	0.000	0.000	0.688	0.750	0.607	0.000	<b>0.837</b>	0.000	0.000	0.771	0.745	0.821	0.000	<b>0.804</b>	0.000	0.000	<b>0.839</b>
<b>Lights</b>	35	144	24	0	<b>203</b>	0	0	22	134	26	0	<b>182</b>	0	0	22	103	17	0	<b>142</b>	0	0	36	144	23	0	<b>203</b>	0	0	<b>730</b>
<b>% Lights</b>	100.0%	95.4%	82.8%	0.0%	<b>94.4%</b>	0.0%	0.0%	95.7%	95.0%	100.0%	0.0%	<b>93.8%</b>	0.0%	0.0%	100.0%	92.8%	100.0%	0.0%	<b>92.2%</b>	0.0%	0.0%	97.3%	96.6%	100.0%	0.0%	<b>97.1%</b>	0.0%	0.0%	<b>94.6%</b>
<b>Trucks</b>	0	0	0	0	<b>0</b>	0	0	0	0	0	0	<b>0</b>	0	0	0	1	0	0	<b>1</b>	0	0	0	0	0	0	<b>0</b>	0	0	<b>1</b>
<b>% Trucks</b>	0.0%	0.0%	0.0%	0.0%	<b>0.0%</b>	0.0%	0.0%	0.0%	0.0%	0.0%	0.0%	<b>0.0%</b>	0.0%	0.0%	0.0%	0.9%	0.0%	0.0%	<b>0.6%</b>	0.0%	0.0%	0.0%	0.0%	0.0%	0.0%	<b>0.0%</b>	0.0%	0.0%	<b>0.1%</b>
<b>Buses</b>	0	7	5	0	<b>12</b>	0	0	1	7	0	0	<b>8</b>	0	0	0	7	0	0	<b>7</b>	0	0	1	5	0	0	<b>6</b>	0	0	<b>33</b>
<b>% Buses</b>	0.0%	4.6%	17.2%	0.0%	<b>0.0%</b>	0.0%	0.0%	4.3%	5.0%	0.0%	0.0%	<b>0.0%</b>	0.0%	0.0%	0.0%	6.3%	0.0%	0.0%	<b>0.0%</b>	0.0%	0.0%	2.7%	3.4%	0.0%	0.0%	<b>0.0%</b>	0.0%	0.0%	<b>4.3%</b>
<b>Pedestrians</b>	0	0	0	0	<b>0</b>	0	4	0	0	0	0	<b>0</b>	1	3	0	0	0	0	<b>0</b>	3	0	0	0	0	0	<b>0</b>	4	6	<b>0</b>
<b>% Pedestrians</b>	0.0%	0.0%	0.0%	0.0%	<b>0.0%</b>	0.0%	100.0%	0.0%	0.0%	0.0%	0.0%	<b>0.0%</b>	100.0%	100.0%	0.0%	0.0%	0.0%	0.0%	<b>0.0%</b>	0.0%	75.0%	0.0%	0.0%	0.0%	0.0%	<b>0.0%</b>	100.0%	100.0%	<b>0.0%</b>
<b>Bicycles on Crosswalk</b>	0	0	0	0	<b>0</b>	0	0	0	0	0	0	<b>0</b>	0	0	0	0	0	0	<b>0</b>	0	1	0	0	0	0	<b>0</b>	0	0	<b>0</b>
<b>% Bicycles on Crosswalk</b>	0.0%	0.0%	0.0%	0.0%	<b>0.0%</b>	0.0%	0.0%	0.0%	0.0%	0.0%	0.0%	<b>0.0%</b>	0.0%	0.0%	0.0%	0.0%	0.0%	0.0%	<b>0.0%</b>	0.0%	25.0%	0.0%	0.0%	0.0%	0.0%	<b>0.0%</b>	0.0%	0.0%	<b>0.0%</b>

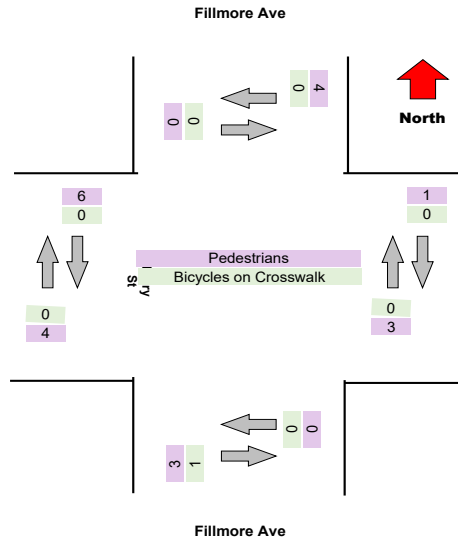
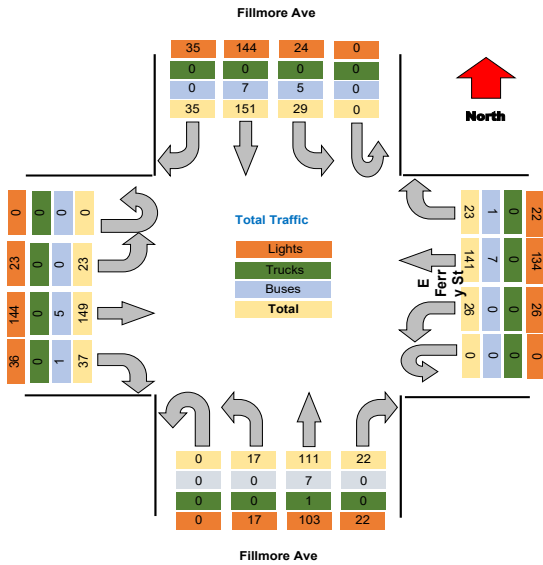

**Turning Movement Peak Hour Data (PM)**

4:30:00 PM

Leg Direction	Fillmore Ave										E Ferry St										Fillmore Ave										E Ferry St										Total																
	Southbound					Westbound					Northbound					Eastbound					Northbound					Eastbound																															
	Right	Thru	Left	U-Turn	App Total	Right	Thru	Left	U-Turn	App Total	Right	Thru	Left	U-Turn	App Total	Right	Thru	Left	U-Turn	App Total	Right	Thru	Left	U-Turn	App Total	Right	Thru	Left	U-Turn	App Total	Right	Thru	Left	U-Turn	App Total																						
4:30:00 PM	14	61	11	0	86	2	1	13	53	9	0	75	0	1	17	50	10	0	77	0	0	15	61	4	0	80	0	1	16	54	8	0	76	2	3	27	51	12	0	90	0	2	25	56	12	0	94	0	1	84	233	32	0	349	3	5	1379
4:45:00 PM	10	59	10	0	79	1	1	14	50	15	0	79	1	1	14	54	8	0	76	2	3	16	65	4	0	85	0	1	24	64	15	0	103	0	3	27	51	12	0	90	0	2	25	56	12	0	94	0	1	84	233	32	0	349	3	5	1379
5:00:00 PM	11	62	11	0	84	1	1	17	63	18	0	98	0	0	16	64	18	0	98	0	0	15	64	18	0	98	0	0	27	51	12	0	90	0	2	25	56	12	0	94	0	1	84	233	32	0	349	3	5	1379							
5:15:00 PM	11	62	11	0	84	1	1	17	63	18	0	98	0	0	16	64	18	0	98	0	0	15	64	18	0	98	0	0	27	51	12	0	90	0	2	25	56	12	0	94	0	1	84	233	32	0	349	3	5	1379							
Grand Total	59	239	47	0	344	0	0	57	220	52	0	329	0	0	63	226	49	0	338	0	0	83	230	32	0	345	0	0	84	233	32	0	349	3	5	1379																					
% Approach	16.8%	69.0%	13.4%	0.0%	0.0%	17.3%	66.6%	16.1%	0.0%	0.0%	18.4%	67.3%	14.3%	0.0%	0.0%	24.1%	66.8%	9.2%	0.0%	0.0%	24.1%	66.8%	9.2%	0.0%	0.0%	24.1%	66.8%	9.2%	0.0%	0.0%	24.1%	66.8%	9.2%	0.0%	0.0%	24.1%	66.8%	9.2%	0.0%	0.0%	24.1%	66.8%	9.2%	0.0%	0.0%												
% Total	4.3%	17.8%	3.4%	0.0%	25.6%	4.2%	16.2%	3.9%	0.0%	24.3%	4.6%	16.8%	3.6%	0.0%	24.9%	6.1%	16.9%	2.3%	0.0%	25.3%	6.1%	16.9%	2.3%	0.0%	25.3%	6.1%	16.9%	2.3%	0.0%	25.3%	6.1%	16.9%	2.3%	0.0%	25.3%	6.1%	16.9%	2.3%	0.0%	25.3%	6.1%	16.9%	2.3%	0.0%	25.3%												
PHF	0.615	0.961	0.783	0.000	0.854	0.853	0.885	0.750	0.000	0.855	0.926	0.902	0.681	0.000	0.875	0.778	0.896	0.667	0.000	0.928	0.778	0.896	0.667	0.000	0.928	0.778	0.896	0.667	0.000	0.928	0.778	0.896	0.667	0.000	0.928	0.778	0.896	0.667	0.000	0.928	0.778	0.896	0.667	0.000	0.928												
Lights	59	239	46	0	344	57	220	52	0	329	63	226	49	0	338	83	230	32	0	345	84	233	32	0	349	83	230	32	0	345	84	233	32	0	349	84	233	32	0	349	84	233	32	0	349												
% Lights	100.0%	97.2%	97.9%	0.0%	97.7%	98.3%	98.7%	96.3%	0.0%	98.2%	100.0%	97.8%	100.0%	0.0%	98.5%	98.8%	98.7%	100.0%	0.0%	98.9%	98.8%	98.7%	100.0%	0.0%	98.9%	98.8%	98.7%	100.0%	0.0%	98.9%	98.8%	98.7%	100.0%	0.0%	98.9%	98.8%	98.7%	100.0%	0.0%	98.9%																	
Trucks	0	2	0	0	2	0	0	0	0	0	0	1	0	0	1	0	0	0	0	0	0	0	0	0	0	0	0	0	0	0	0	0	0	0	0	0	0	0	0	0																	
% Trucks	0.0%	0.8%	0.0%	0.0%	0.6%	0.0%	0.0%	0.0%	0.0%	0.0%	0.0%	0.4%	0.0%	0.0%	0.3%	0.0%	0.0%	0.0%	0.0%	0.0%	0.0%	0.0%	0.0%	0.0%	0.0%	0.0%	0.0%	0.0%	0.0%	0.0%	0.0%	0.0%	0.0%	0.0%	0.0%																						
Buses	0	5	1	0	6	1	3	2	0	6	0	3	0	0	3	1	2	0	0	3	2	0	0	0	2	0	0	0	0	0	0	0	0	0	0	0	0	0	0	0																	
% Buses	0.0%	2.0%	2.1%	0.0%	0.0%	1.7%	1.3%	3.7%	0.0%	0.0%	0.0%	1.3%	0.0%	0.0%	0.0%	1.2%	0.9%	0.0%	0.0%	0.0%	1.2%	0.9%	0.0%	0.0%	0.0%	0.0%	0.0%	0.0%	0.0%	0.0%	0.0%	0.0%	0.0%	0.0%	0.0%																						
Pedestrians	0	0	0	0	0	4	6	0	0	10	0	0	0	0	0	4	4	0	0	8	0	0	0	0	0	0	0	0	0	0	0	0	0	0	0	0	0	0	0	0																	
% Pedestrians	0.0%	0.0%	0.0%	0.0%	0.0%	100.0%	100.0%	0.0%	0.0%	0.0%	0.0%	0.0%	0.0%	0.0%	0.0%	66.7%	100.0%	0.0%	0.0%	0.0%	0.0%	0.0%	0.0%	0.0%	0.0%	0.0%	0.0%	0.0%	0.0%	0.0%	0.0%	0.0%	0.0%	0.0%	0.0%																						
Bicycles on Crosswalk	0	0	0	0	0	0	0	0	0	0	0	0	0	0	0	2	0	0	0	2	0	0	0	0	0	0	0	0	0	0	0	0	0	0	0	0	0	0	0	0																	
% Bicycles on Crosswalk	0.0%	0.0%	0.0%	0.0%	0.0%	0.0%	0.0%	0.0%	0.0%	0.0%	0.0%	0.0%	0.0%	0.0%	0.0%	33.3%	0.0%	0.0%	0.0%	0.0%	0.0%	0.0%	0.0%	0.0%	0.0%	0.0%	0.0%	0.0%	0.0%	0.0%	0.0%	0.0%	0.0%	0.0%	0.0%																						

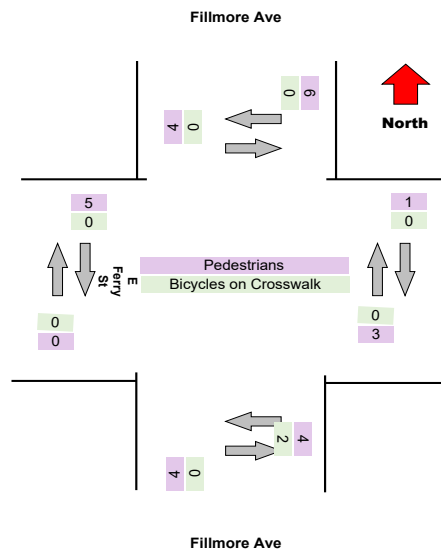
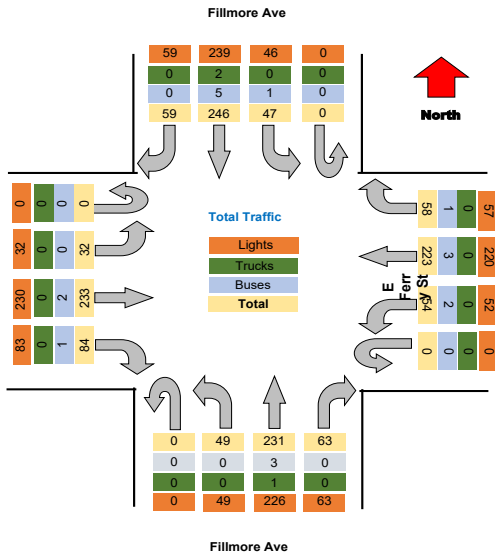

Project : VBH Malta NY  
 Site : Site 4  
 Location : 42.948550, -73.790036

TSTData.com

Survey Date : 2021-04-28, Wednesday

<b>Project</b>	LaBella
<b>Project Code</b>	LaBella
<b>Site Name</b>	24
<b>Legs and Movements</b>	All Processed Legs & Move
<b>Bin Size</b>	15 minutes
<b>Survey Date</b>	2021-11-03, Wednesday
<b>Location</b>	24
<b>Latitude and Longitude</b>	42.914640, -78.839098

	Start	End	PHF
Forced Peak AM	2021/11/03 07:30:00	2021/11/03 08:30:00	0.89
Forced Peak PM	2021/11/03 16:30:00	2021/11/03 17:30:00	0.97
AM Peak	2021/11/03 07:30:00	2021/11/03 08:30:00	0.89
PM Peak	2021/11/03 16:30:00	2021/11/03 17:30:00	0.97

### Turning Movement Data

Leg Direction	Fillmore Ave Southbound							E Ferry St Westbound							Fillmore Ave Northbound							E Ferry St Eastbound							Total
	Right	Thru	Left	U-Turn	App Total	Peds CV	Peds CCV	Right	Thru	Left	U-Turn	App Total	Peds CV	Peds CCV	Right	Thru	Left	U-Turn	App Total	Peds CV	Peds CCV	Right	Thru	Left	U-Turn	App Total	Peds CV	Peds CCV	
	Start Time							Start Time							Start Time							Start Time							
6:30:00 AM	3	21	6	0	30	0	3	6	30	4	0	43	0	1	4	12	4	0	21	0	0	9	21	3	0	33	0	0	127
6:45:00 AM	9	20	3	0	32	0	7	11	25	2	0	39	0	1	4	31	8	0	44	0	0	4	28	3	0	35	0	0	150
Hourly Total	12	41	9	0	62	0	4	17	55	6	0	82	0	2	8	43	12	0	65	0	0	13	49	6	0	68	0	0	277
7:00:00 AM	8	37	3	0	48	0	1	8	28	3	0	40	3	1	4	24	6	0	38	0	0	8	30	5	0	41	2	2	167
7:15:00 AM	11	33	9	0	53	1	0	9	36	3	0	48	1	4	3	32	1	0	41	0	0	15	42	9	0	66	0	0	208
7:30:00 AM	15	52	6	0	73	2	5	15	45	5	0	70	0	6	8	29	3	0	46	0	2	12	51	13	1	77	5	0	266
7:45:00 AM	16	76	9	0	101	0	0	9	50	6	0	65	0	1	8	58	2	0	69	0	0	11	63	19	0	93	0	0	328
Hourly Total	50	198	27	0	275	3	6	41	159	17	0	223	4	12	23	143	12	0	194	0	2	44	186	46	1	277	7	2	969
8:00:00 AM	13	72	12	0	97	0	1	11	53	9	0	74	1	2	14	42	7	0	68	2	1	16	35	9	0	60	1	2	297
8:15:00 AM	15	60	4	0	79	1	0	11	41	8	0	60	1	0	7	45	9	0	62	0	0	15	46	6	0	67	0	0	268
Hourly Total	28	132	16	0	176	1	1	22	94	17	0	134	2	2	21	87	16	0	128	2	1	31	81	15	0	127	1	2	565
4:00:00 PM	20	62	12	0	94	2	2	21	70	12	0	103	2	1	13	61	8	0	82	0	0	22	79	11	0	112	2	3	391
4:15:00 PM	23	80	12	0	115	2	2	18	58	6	0	82	1	0	15	75	10	0	100	0	1	19	74	15	0	108	1	2	405
4:30:00 PM	20	81	5	0	106	1	2	7	59	6	0	74	1	2	13	57	9	0	79	0	0	18	73	10	0	101	1	0	360
4:45:00 PM	14	61	7	0	82	1	0	10	61	17	0	89	0	1	14	65	5	0	104	0	0	19	68	7	0	94	1	2	368
Hourly Total	77	284	36	0	397	6	8	56	248	43	0	347	4	4	55	278	32	0	365	0	1	78	294	43	0	415	5	7	1524
5:00:00 PM	21	69	11	0	91	0	1	15	55	12	0	82	0	1	16	53	14	0	83	0	0	21	64	11	0	96	1	2	352
5:15:00 PM	13	63	15	0	91	1	0	14	62	13	0	89	0	0	12	64	9	0	85	3	1	21	50	7	0	78	2	1	343
5:30:00 PM	17	55	8	0	80	0	1	16	45	12	0	73	0	0	11	46	14	0	71	0	0	11	62	8	0	81	3	1	305
5:45:00 PM	10	54	9	0	73	0	0	12	51	10	0	73	1	1	15	47	11	0	73	0	0	17	62	3	0	82	0	0	301
Hourly Total	61	231	43	0	335	1	2	57	213	47	0	317	1	2	54	210	48	0	312	3	3	70	238	29	0	337	6	4	1301
Grand Total	228	886	131	0	1245	11	21	193	769	130	0	1103	11	22	161	761	120	0	1084	5	7	236	848	139	1	1224	19	15	4636
% Approach	18.3%	71.2%	10.5%	0.0%	0.0%	0.0%	0.0%	17.5%	69.7%	11.8%	0.0%	0.0%	0.0%	0.0%	15.1%	71.5%	11.3%	0.0%	0.0%	0.0%	0.0%	19.3%	69.3%	11.4%	0.1%	0.0%	0.0%	0.0%	0.0%
% Total	4.9%	19.1%	2.8%	0.0%	26.9%	0.0%	0.0%	4.2%	16.6%	2.8%	0.0%	23.9%	0.0%	0.0%	3.5%	16.4%	2.6%	0.0%	23.0%	0.0%	0.0%	5.1%	18.3%	3.0%	0.0%	26.4%	0.0%	0.0%	0.0%
Lights	216	831	123	0	1170	0	0	177	732	120	0	1029	0	0	147	717	109	0	973	0	0	224	806	128	1	1159	0	0	4331
% Lights	94.7%	93.8%	93.9%	0.0%	94.0%	0.0%	0.0%	91.7%	95.2%	92.3%	0.0%	93.3%	0.0%	0.0%	91.3%	94.2%	90.8%	0.0%	91.4%	0.0%	0.0%	94.9%	95.0%	92.1%	###	94.7%	0.0%	0.0%	93.4%
Trucks	0	1	0	0	1	0	0	1	0	1	0	2	0	0	1	1	0	0	2	0	0	0	0	0	0	0	0	0	5
% Trucks	0.0%	0.1%	0.0%	0.0%	0.1%	0.0%	0.0%	0.5%	0.0%	0.8%	0.0%	0.2%	0.0%	0.0%	0.6%	0.1%	0.0%	0.0%	0.2%	0.0%	0.0%	0.0%	0.0%	0.0%	0.0%	0.0%	0.0%	0.0%	0.1%
Buses	12	54	8	0	74	0	0	15	37	9	0	61	0	0	13	43	11	0	67	0	0	12	41	11	0	64	0	0	266
% Buses	5.3%	6.1%	6.1%	0.0%	0.0%	0.0%	0.0%	0.0%	4.8%	6.9%	0.0%	0.0%	0.0%	0.0%	8.1%	5.7%	9.2%	0.0%	0.0%	0.0%	0.0%	5.1%	4.8%	7.9%	0.0%	0.0%	0.0%	0.0%	5.7%
Pedestrians	0	0	0	0	0	11	21	0	0	0	0	0	11	20	0	0	0	0	0	5	7	0	0	0	0	0	17	14	0
% Pedestrians	0.0%	0.0%	0.0%	0.0%	0.0%	100.0%	100.0%	0.0%	0.0%	0.0%	0.0%	0.0%	100.0%	90.9%	0.0%	0.0%	0.0%	0.0%	0.0%	100.0%	100.0%	0.0%	0.0%	0.0%	0.0%	0.0%	89.6%	83.3%	0.0%
Bicycles on Crosswalk	0	0	0	0	0	0	0	0	0	0	0	0	0	2	0	0	0	0	0	0	0	0	0	0	0	0	2	1	0
% Bicycles on Crosswalk	0.0%	0.0%	0.0%	0.0%	0.0%	0.0%	0.0%	0.0%	0.0%	0.0%	0.0%	0.0%	0.0%	9.1%	0.0%	0.0%	0.0%	0.0%	0.0%	0.0%	0.0%	0.0%	0.0%	0.0%	0.0%	0.0%	10.5%	6.7%	0.0%

Project : VBH Malta NY  
 Site : Site 4  
 Location : 42.948550, -73.790036  
 Survey Date : 2021-04-28, Wednesday

### Turning Movement Data Plot

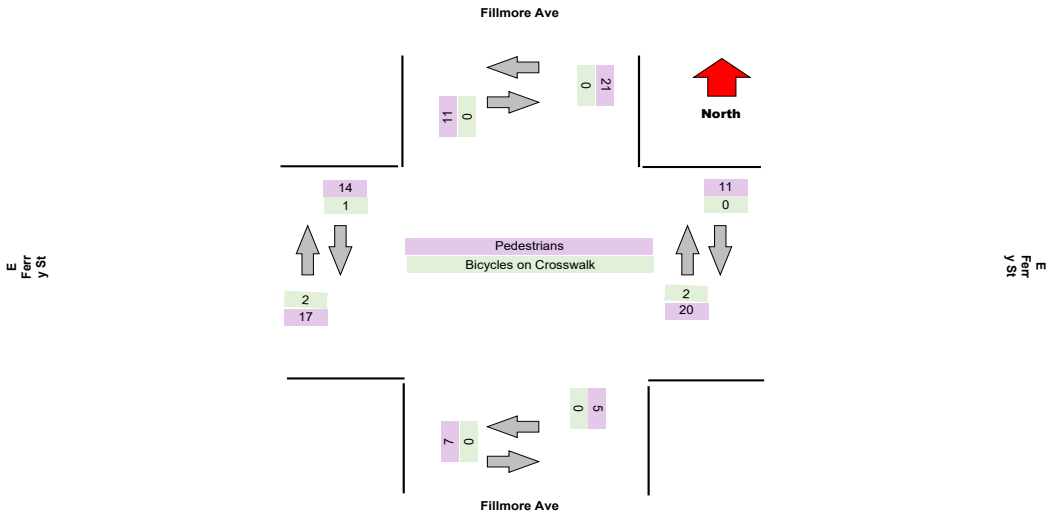
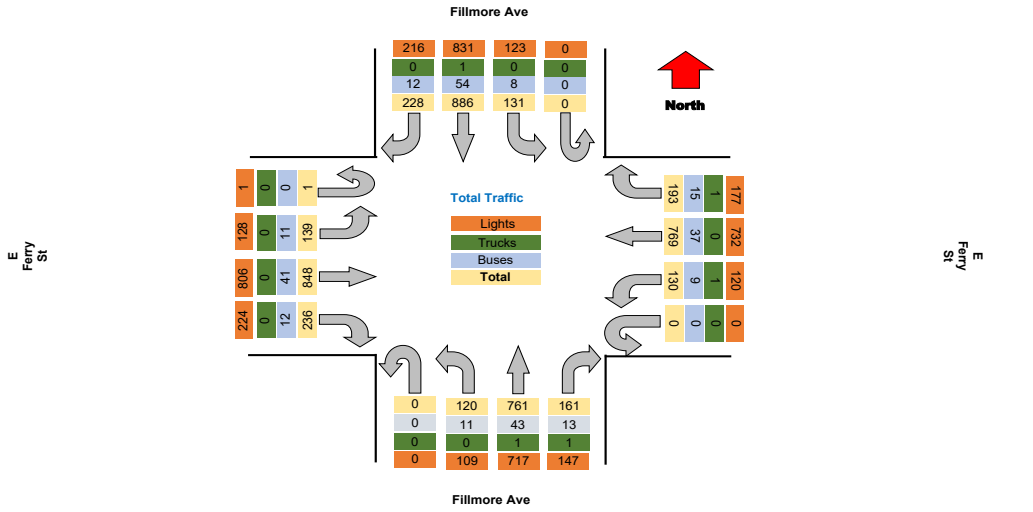



Project : VBH Malta NY  
Site : Site 4  
Location : 42.948550, -73.790036

TSTData.com

Survey Date : 2021-04-28, Wednesday

### Turning Movement Peak Hour Data (AM)

7:30:00 AM

Leg Direction	Fillmore Ave						E Ferry St						Fillmore Ave						E Ferry St						Total
	Southbound			Westbound			Northbound			Eastbound			Northbound			Eastbound									
Start Time	Right	Thru	Left	U-Turn	App Total	Peds CW	Peds CCW	Right	Thru	Left	U-Turn	App Total	Peds CW	Peds CCW	Right	Thru	Left	U-Turn	App Total	Peds CW	Peds CCW	Total			
7:30:00 AM	15	52	6	0	73	2	5	15	45	5	0	70	0	6	8	29	3	0	46	0	2	266			
7:45:00 AM	16	76	9	0	101	0	0	9	50	6	0	65	0	1	8	58	2	0	69	0	0	328			
8:00:00 AM	13	72	12	0	97	0	1	11	53	9	0	74	1	2	14	42	7	0	66	2	1	297			
8:15:00 AM	15	60	4	0	79	1	0	11	41	8	0	60	1	0	7	45	9	0	62	0	0	268			
<b>Grand Total</b>	<b>59</b>	<b>269</b>	<b>31</b>	<b>0</b>	<b>359</b>	<b>3</b>	<b>6</b>	<b>46</b>	<b>199</b>	<b>28</b>	<b>0</b>	<b>259</b>	<b>2</b>	<b>9</b>	<b>37</b>	<b>174</b>	<b>21</b>	<b>0</b>	<b>243</b>	<b>2</b>	<b>3</b>	<b>1189</b>			
% Approach	16.9%	74.3%	8.9%	0.0%	0.0%	0.0%	0.0%	17.1%	70.3%	10.4%	0.0%	0.0%	0.0%	0.0%	15.2%	71.6%	8.6%	0.0%	0.0%	0.0%	0.0%	0.0%	0.0%		
% Total	5.1%	22.4%	2.7%	0.0%	30.2%	0.0%	0.0%	4.0%	16.3%	2.4%	0.0%	23.2%	0.0%	0.0%	3.2%	15.0%	1.8%	0.0%	21.0%	0.0%	0.0%	0.0%	0.0%		
PHF	0.922	0.855	0.646	0.000	0.866	0.000	0.000	0.767	0.892	0.778	0.000	0.909	0.000	0.000	0.661	0.750	0.583	0.000	0.880	0.000	0.000	0.000	0.883		
Lights	55	245	30	0	330	0	0	44	182	25	0	251	0	0	34	159	17	0	210	0	0	1068			
% Lights	83.2%	94.2%	96.8%	0.0%	94.3%	0.0%	0.0%	85.7%	96.3%	89.3%	0.0%	93.3%	0.0%	0.0%	81.9%	91.4%	81.0%	0.0%	86.4%	0.0%	0.0%	92.1%			
Trucks	0	0	0	0	0	0	0	0	0	0	0	0	0	0	0	0	0	0	0	0	0	0	0		
% Trucks	0.0%	0.0%	0.0%	0.0%	0.0%	0.0%	0.0%	0.0%	0.0%	0.0%	0.0%	0.0%	0.0%	0.0%	0.0%	0.0%	0.0%	0.0%	0.0%	0.0%	0.0%	0.0%	0.0%		
Buses	4	15	1	0	20	0	0	2	7	3	0	12	0	0	3	15	4	0	22	0	0	74			
% Buses	6.8%	5.8%	3.2%	0.0%	0.0%	0.0%	0.0%	4.3%	3.7%	10.7%	0.0%	0.0%	0.0%	0.0%	8.1%	8.8%	19.0%	0.0%	0.0%	0.0%	0.0%	6.4%			
Pedestrians	0	0	0	0	0	3	6	0	0	0	0	0	2	9	0	0	0	0	0	2	3	0	0		
% Pedestrians	0.0%	0.0%	0.0%	0.0%	0.0%	100.0%	100.0%	0.0%	0.0%	0.0%	0.0%	0.0%	100.0%	100.0%	0.0%	0.0%	0.0%	0.0%	0.0%	100.0%	100.0%	0.0%	0.0%		
Bicycles on Crosswalk	0	0	0	0	0	0	0	0	0	0	0	0	0	0	0	0	0	0	0	0	0	0	0		
% Bicycles on Crosswalk	0.0%	0.0%	0.0%	0.0%	0.0%	0.0%	0.0%	0.0%	0.0%	0.0%	0.0%	0.0%	0.0%	0.0%	0.0%	0.0%	0.0%	0.0%	0.0%	0.0%	0.0%	0.0%	0.0%		

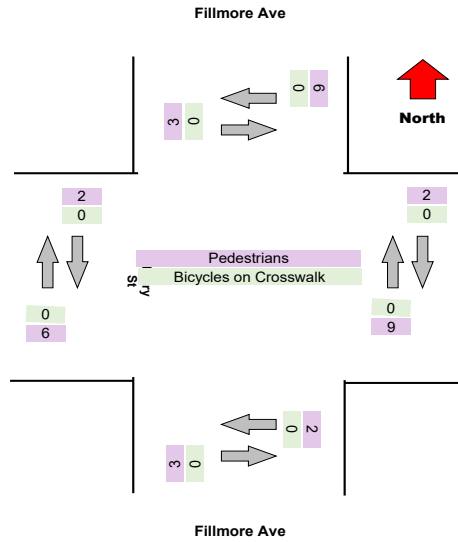
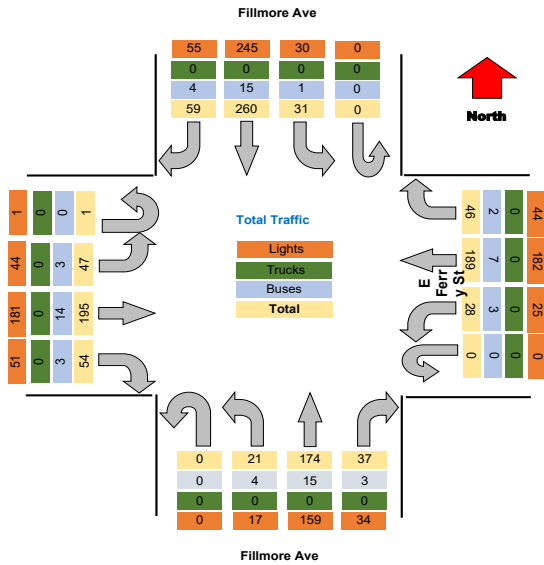

**Turning Movement Peak Hour Data (PM)**

4:30:00 PM

Leg Direction	Fillmore Ave										E Ferry St										Fillmore Ave										E Ferry St										Total
	Southbound					Westbound					Northbound					Eastbound																									
	Right	Thru	Left	U-Turn	App Total	Right	Thru	Left	U-Turn	App Total	Right	Thru	Left	U-Turn	App Total	Right	Thru	Left	U-Turn	App Total																					
4:30:00 PM	20	81	5	0	106	1	2	7	59	8	0	74	13	57	9	0	79	0	0	18	73	10	0	101	1	1	0	0	360												
4:45:00 PM	14	61	7	0	82	1	2	10	61	17	0	88	0	1	14	85	5	0	104	0	0	19	68	7	0	94	1	2	0	0	368										
5:00:00 PM	21	59	11	0	91	0	1	15	55	12	0	82	0	1	16	53	14	0	83	0	0	21	64	7	0	96	1	2	0	0	352										
5:15:00 PM	13	63	15	0	91	0	0	14	62	13	0	89	0	0	12	64	9	0	85	0	0	21	50	7	0	78	2	1	0	0	343										
<b>Grand Total</b>	<b>68</b>	<b>264</b>	<b>38</b>	<b>0</b>	<b>370</b>	<b>3</b>	<b>5</b>	<b>46</b>	<b>237</b>	<b>50</b>	<b>0</b>	<b>333</b>	<b>1</b>	<b>1</b>	<b>55</b>	<b>259</b>	<b>37</b>	<b>0</b>	<b>351</b>	<b>3</b>	<b>1</b>	<b>79</b>	<b>255</b>	<b>35</b>	<b>0</b>	<b>369</b>	<b>3</b>	<b>5</b>	<b>0</b>	<b>0</b>	<b>1423</b>										
% Approach	18.4%	71.4%	10.3%	0.0%	0.0%	0.0%	0.0%	13.8%	71.2%	15.0%	0.0%	0.0%	0.0%	0.0%	15.7%	73.6%	10.5%	0.0%	0.0%	0.0%	0.0%	21.4%	69.1%	9.5%	0.0%	0.0%	0.0%	0.0%	0.0%	0.0%	0.0%										
% Total	4.8%	18.6%	2.7%	0.0%	26.0%	0.0%	0.0%	3.2%	16.7%	3.5%	0.0%	23.4%	0.0%	0.0%	3.9%	18.2%	2.6%	0.0%	24.7%	0.0%	0.0%	5.6%	17.9%	2.5%	0.0%	25.9%	0.0%	0.0%	0.0%	0.0%	0.0%										
PHF	0.810	0.815	0.633	0.000	0.873	0.000	0.000	0.767	0.956	0.735	0.000	0.935	0.000	0.000	0.859	0.762	0.661	0.000	0.844	0.000	0.000	0.940	0.873	0.795	0.000	0.913	0.000	0.000	0.000	0.000	0.967										
Lights	66	250	38	0	354	0	0	42	230	48	0	320	0	0	50	250	35	0	335	0	0	77	245	32	0	354	0	0	0	0	1363										
% Lights	97.1%	94.7%	100.0%	0.0%	95.7%	0.0%	0.0%	81.3%	97.0%	96.0%	0.0%	96.1%	0.0%	0.0%	90.9%	96.5%	94.6%	0.0%	95.4%	0.0%	0.0%	97.5%	96.1%	91.4%	0.0%	95.9%	0.0%	0.0%	0.0%	0.0%	95.8%										
Trucks	0	1	0	0	1	0	0	0	0	0	0	0	0	0	0	1	0	0	1	0	0	0	0	0	0	0	0	0	0	0	2										
% Trucks	0.0%	0.4%	0.0%	0.0%	0.3%	0.0%	0.0%	0.0%	0.0%	0.0%	0.0%	0.0%	0.0%	0.0%	0.0%	0.4%	0.0%	0.0%	0.3%	0.0%	0.0%	0.0%	0.0%	0.0%	0.0%	0.0%	0.0%	0.0%	0.0%	0.0%	0.1%										
Buses	2	13	0	0	15	4	7	2	0	13	0	0	5	8	2	0	15	0	0	2	9	3	0	14	0	0	0	0	57												
% Buses	2.9%	4.9%	0.0%	0.0%	0.0%	8.7%	3.0%	4.0%	0.0%	0.0%	0.0%	0.0%	9.1%	3.1%	5.4%	0.0%	0.0%	0.0%	0.0%	2.5%	3.5%	8.6%	0.0%	0.0%	0.0%	0.0%	0.0%	0.0%	4.0%												
Pedestrians	0	0	0	0	0	3	5	0	0	8	1	3	0	0	4	3	1	0	0	4	0	0	0	0	0	0	0	3	5	0	0	8									
% Pedestrians	0.0%	0.0%	0.0%	0.0%	0.0%	100.0%	100.0%	0.0%	0.0%	0.0%	0.0%	75.0%	0.0%	0.0%	0.0%	100.0%	100.0%	0.0%	0.0%	0.0%	0.0%	0.0%	0.0%	0.0%	0.0%	0.0%	0.0%	60.0%	100.0%	0.0%	0.0%	0.0%									
Bicycles on Crosswalk	0	0	0	0	0	0	0	0	0	0	0	1	0	0	1	0	0	0	0	0	0	0	0	0	0	0	0	0	2	0	0	2									
% Bicycles on Crosswalk	0.0%	0.0%	0.0%	0.0%	0.0%	0.0%	0.0%	0.0%	0.0%	0.0%	0.0%	25.0%	0.0%	0.0%	0.0%	0.0%	0.0%	0.0%	0.0%	0.0%	0.0%	0.0%	0.0%	0.0%	0.0%	0.0%	0.0%	0.0%	40.0%	0.0%	0.0%	0.0%									

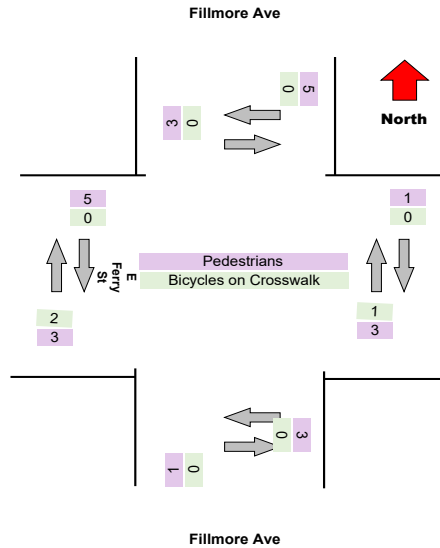
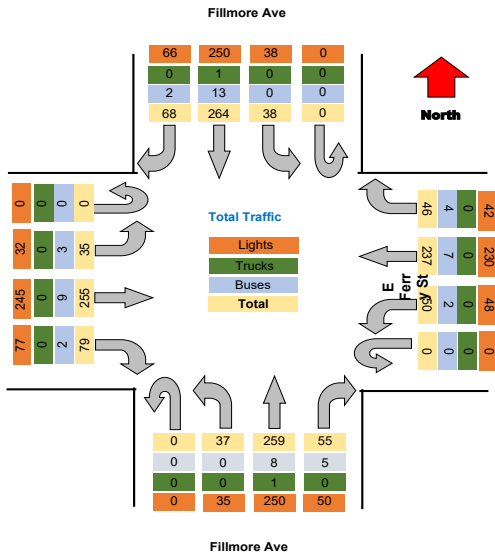

Project : VBH Malta NY  
 Site : Site 4  
 Location : 42.948550, -73.790036

TSTData.com

Survey Date : 2021-04-28, Wednesday

Project	LaBella
Project Code	LaBella
Site Name	25
Legs and Movements	All Processed Legs & Move
Bin Size	15 minutes
Survey Date	2021-11-02, Tuesday
Location	25
Latitude and Longitude	42.919082, -78.839282

	Start	End	PHF
Forced Peak AM	2021/11/02 07:30:00	2021/11/02 08:30:00	0.78
Forced Peak PM	2021/11/02 16:30:00	2021/11/02 17:30:00	0.93
AM Peak	2021/11/02 07:30:00	2021/11/02 08:30:00	0.78
PM Peak	2021/11/02 16:45:00	2021/11/02 17:45:00	0.92

### Turning Movement Data

Leg Direction	Fillmore Ave							Northland Ave							Fillmore Ave							Northland Ave							Total
	Southbound							Westbound							Northbound							Eastbound							
	Right	Thru	Left	U-Turn	App Total	Peds CV	Peds CCV	Right	Thru	Left	U-Turn	App Total	Peds CV	Peds CCV	Right	Thru	Left	U-Turn	App Total	Peds CV	Peds CCV	Right	Thru	Left	U-Turn	App Total	Peds CV	Peds CCV	
6:30:00 AM	0	16	4	0	<b>20</b>	0	1	0	4	4	0	<b>9</b>	0	0	4	15	1	0	<b>20</b>	0	0	1	3	0	0	<b>4</b>	0	0	<b>53</b>
6:45:00 AM	0	18	8	0	<b>26</b>	0	0	2	6	1	0	<b>9</b>	0	0	4	19	4	0	<b>27</b>	0	1	0	8	1	0	<b>9</b>	0	0	<b>71</b>
Hourly Total	0	34	12	0	<b>46</b>	0	1	2	10	5	0	<b>18</b>	0	0	8	34	5	0	<b>47</b>	0	1	1	11	1	0	<b>13</b>	0	0	<b>124</b>
7:00:00 AM	1	18	5	0	<b>24</b>	0	0	1	2	1	0	<b>4</b>	0	1	2	24	0	0	<b>27</b>	0	0	4	5	0	0	<b>9</b>	0	0	<b>64</b>
7:15:00 AM	3	30	8	0	<b>41</b>	1	0	2	5	1	0	<b>8</b>	0	0	2	26	1	0	<b>29</b>	1	0	2	8	0	0	<b>10</b>	1	0	<b>88</b>
7:30:00 AM	7	31	8	0	<b>46</b>	0	1	2	7	4	0	<b>14</b>	0	0	3	22	2	0	<b>27</b>	0	0	2	8	0	0	<b>10</b>	0	1	<b>97</b>
7:45:00 AM	2	54	9	0	<b>65</b>	1	1	0	10	6	0	<b>17</b>	0	0	5	37	3	0	<b>45</b>	0	0	5	12	3	0	<b>20</b>	1	1	<b>147</b>
Hourly Total	13	133	30	0	<b>176</b>	2	2	5	24	12	0	<b>43</b>	0	1	12	109	6	0	<b>128</b>	1	0	13	33	3	0	<b>49</b>	2	2	<b>396</b>
8:00:00 AM	3	50	4	0	<b>57</b>	1	0	2	7	2	0	<b>11</b>	0	0	5	33	0	0	<b>38</b>	1	1	1	5	0	0	<b>6</b>	1	1	<b>112</b>
8:15:00 AM	3	52	1	0	<b>56</b>	0	0	2	3	2	0	<b>7</b>	0	0	3	26	2	0	<b>31</b>	0	0	1	6	2	0	<b>9</b>	0	0	<b>103</b>
Hourly Total	6	102	5	0	<b>113</b>	1	0	4	10	4	0	<b>18</b>	0	0	8	59	2	0	<b>69</b>	1	1	2	11	2	0	<b>15</b>	1	1	<b>215</b>
4:00:00 PM	11	78	6	0	<b>95</b>	0	0	8	16	7	0	<b>31</b>	0	0	6	62	1	0	<b>69</b>	0	0	3	6	3	0	<b>12</b>	0	1	<b>207</b>
4:15:00 PM	4	68	8	0	<b>80</b>	0	1	4	4	10	0	<b>18</b>	0	0	7	65	3	0	<b>75</b>	0	0	5	10	3	0	<b>18</b>	0	0	<b>191</b>
4:30:00 PM	7	66	8	0	<b>81</b>	0	1	2	13	7	0	<b>22</b>	0	0	2	59	1	0	<b>62</b>	0	1	4	6	2	0	<b>12</b>	1	1	<b>177</b>
4:45:00 PM	7	69	7	0	<b>83</b>	1	0	7	13	9	0	<b>29</b>	0	1	2	61	3	0	<b>66</b>	0	0	5	7	2	0	<b>14</b>	0	1	<b>192</b>
Hourly Total	29	281	29	0	<b>339</b>	1	2	21	48	33	0	<b>100</b>	0	1	17	237	8	0	<b>272</b>	0	1	17	29	10	0	<b>56</b>	1	3	<b>767</b>
5:00:00 PM	5	69	6	0	<b>80</b>	0	0	3	9	15	0	<b>27</b>	0	0	6	77	1	0	<b>84</b>	1	0	7	10	1	0	<b>18</b>	2	1	<b>209</b>
5:15:00 PM	3	71	7	0	<b>81</b>	0	1	3	8	9	0	<b>20</b>	1	0	8	70	7	0	<b>85</b>	0	2	4	10	1	0	<b>15</b>	0	1	<b>201</b>
5:30:00 PM	2	60	3	0	<b>65</b>	1	1	3	5	12	0	<b>20</b>	0	0	4	63	3	0	<b>70</b>	0	0	5	5	0	0	<b>10</b>	1	0	<b>165</b>
5:45:00 PM	5	58	6	0	<b>69</b>	0	0	2	7	10	0	<b>19</b>	0	1	3	50	0	0	<b>53</b>	0	0	6	4	2	0	<b>12</b>	0	0	<b>153</b>
Hourly Total	15	258	22	0	<b>295</b>	1	2	11	29	46	0	<b>86</b>	1	1	21	260	11	0	<b>292</b>	1	2	22	29	4	0	<b>55</b>	3	2	<b>728</b>
Grand Total	63	808	98	0	<b>969</b>	5	7	43	119	100	0	<b>265</b>	1	3	66	709	32	0	<b>808</b>	3	5	55	113	20	0	<b>188</b>	7	8	<b>2230</b>
% Approach	6.5%	83.4%	10.1%	0.0%	<b>0.0%</b>	0.0%	0.0%	16.2%	44.9%	37.7%	0.0%	<b>0.0%</b>	0.0%	0.0%	8.2%	87.7%	4.0%	0.0%	<b>0.0%</b>	0.0%	0.0%	29.3%	60.1%	10.6%	0.0%	<b>0.0%</b>	0.0%	0.0%	<b>0.0%</b>
% Total	2.8%	36.2%	4.4%	0.0%	<b>43.5%</b>	0.0%	0.0%	1.9%	5.3%	4.5%	0.0%	<b>11.9%</b>	0.0%	0.0%	3.0%	31.8%	1.4%	0.0%	<b>36.2%</b>	0.0%	0.0%	2.5%	5.1%	0.9%	0.0%	<b>8.4%</b>	0.0%	0.0%	<b>0.0%</b>
Lights	63	781	98	0	<b>942</b>	0	0	43	119	99	0	<b>261</b>	0	0	66	683	30	0	<b>779</b>	0	0	53	113	20	0	<b>186</b>	0	0	<b>2168</b>
% Lights	100.0%	96.7%	100.0%	0.0%	<b>97.2%</b>	0.0%	0.0%	100.0%	100.0%	99.0%	0.0%	<b>98.5%</b>	0.0%	0.0%	100.0%	96.3%	93.8%	0.0%	<b>96.4%</b>	0.0%	0.0%	96.4%	100.0%	100.0%	0.0%	<b>98.9%</b>	0.0%	0.0%	<b>97.2%</b>
Trucks	0	1	0	0	<b>1</b>	0	0	0	0	0	0	<b>0</b>	0	0	0	1	0	0	<b>1</b>	0	0	0	0	0	0	<b>0</b>	0	0	<b>2</b>
% Trucks	0.0%	0.1%	0.0%	0.0%	<b>0.1%</b>	0.0%	0.0%	0.0%	0.0%	0.0%	0.0%	<b>0.0%</b>	0.0%	0.0%	0.0%	0.1%	0.0%	0.0%	<b>0.1%</b>	0.0%	0.0%	0.0%	0.0%	0.0%	0.0%	<b>0.0%</b>	0.0%	0.0%	<b>0.1%</b>
Buses	0	24	0	0	<b>24</b>	0	0	0	0	1	0	<b>1</b>	0	0	0	25	2	0	<b>27</b>	0	0	2	0	0	0	<b>2</b>	0	0	<b>54</b>
% Buses	0.0%	3.0%	0.0%	0.0%	<b>0.0%</b>	0.0%	0.0%	0.0%	0.0%	1.0%	0.0%	<b>0.0%</b>	0.0%	0.0%	0.0%	3.5%	6.3%	0.0%	<b>0.0%</b>	0.0%	0.0%	3.6%	0.0%	0.0%	0.0%	<b>0.0%</b>	0.0%	0.0%	<b>2.4%</b>
Pedestrians	0	0	0	0	<b>0</b>	5	6	0	0	0	0	<b>0</b>	1	3	0	0	0	0	<b>0</b>	3	5	0	0	0	0	<b>0</b>	7	8	<b>0</b>
% Pedestrians	0.0%	0.0%	0.0%	0.0%	<b>0.0%</b>	100.0%	85.7%	0.0%	0.0%	0.0%	0.0%	<b>0.0%</b>	100.0%	100.0%	0.0%	0.0%	0.0%	0.0%	<b>0.0%</b>	100.0%	100.0%	0.0%	0.0%	0.0%	0.0%	<b>0.0%</b>	100.0%	100.0%	<b>0.0%</b>
Bicycles on Crosswalk	0	0	0	0	<b>0</b>	0	1	0	0	0	0	<b>0</b>	0	0	0	0	0	0	<b>0</b>	0	0	0	0	0	0	<b>0</b>	0	0	<b>0</b>
% Bicycles on Crosswalk	0.0%	0.0%	0.0%	0.0%	<b>0.0%</b>	0.0%	14.3%	0.0%	0.0%	0.0%	0.0%	<b>0.0%</b>	0.0%	0.0%	0.0%	0.0%	0.0%	0.0%	<b>0.0%</b>	0.0%	0.0%	0.0%	0.0%	0.0%	0.0%	<b>0.0%</b>	0.0%	0.0%	<b>0.0%</b>

Project : VBH Malta NY  
 Site : Site 4  
 Location : 42.948550, -73.790036  
 Survey Date : 2021-04-28, Wednesday

### Turning Movement Data Plot

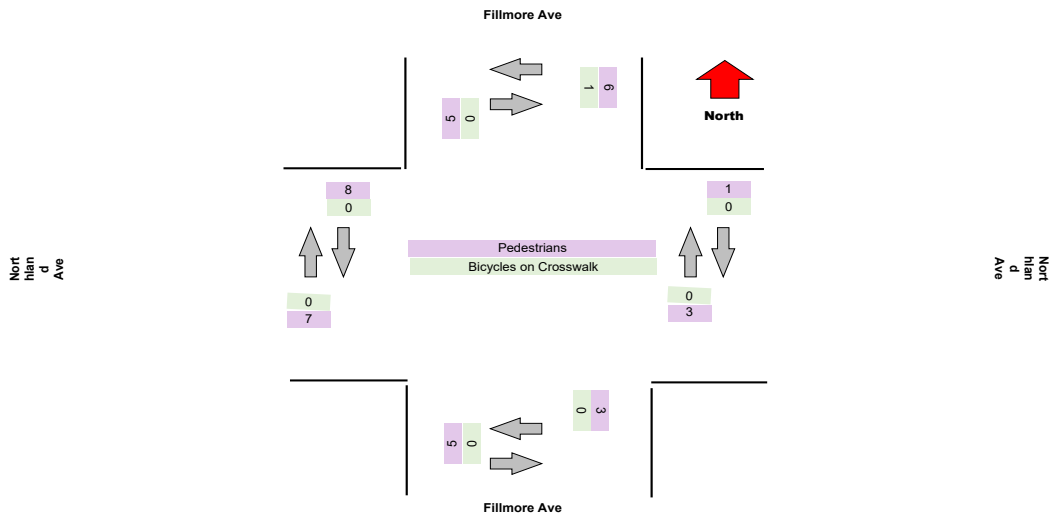
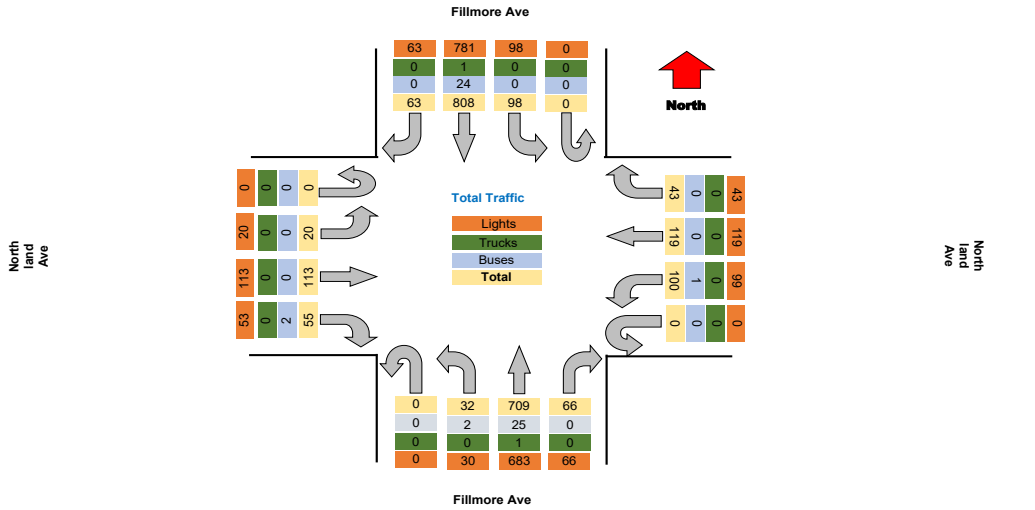

**Turning Movement Peak Hour Data (AM)**

7:30:00 AM

Leg Direction	Fillmore Ave					Northland Ave					Fillmore Ave					Northland Ave					Total									
	Southbound					Westbound					Northbound					Eastbound														
Start Time	Right	Thru	Left	U-Turn	App Total	Peds CW	Peds CCW	Right	Thru	Left	U-Turn	App Total	Peds CW	Peds CCW	Right	Thru	Left	U-Turn	App Total	Peds CW	Peds CCW	Right	Thru	Left	U-Turn	App Total	Peds CW	Peds CCW		
7:30:00 AM	7	31	8	0	46	0	1	2	7	4	0	14	0	0	3	22	2	0	27	0	0	2	8	0	0	10	0	1	97	
7:45:00 AM	2	54	9	0	65	1	1	0	10	6	0	17	0	0	5	37	3	0	45	0	0	5	12	3	0	20	1	1	147	
8:00:00 AM	3	50	4	0	57	1	0	2	7	2	0	11	0	0	5	33	0	0	38	1	1	1	5	0	0	6	1	1	112	
8:15:00 AM	3	52	1	0	56	0	0	2	3	2	0	7	0	0	3	26	2	0	31	0	0	1	6	2	0	9	0	0	103	
<b>Grand Total</b>	15	187	22	0	224	2	2	6	27	14	0	49	0	0	16	118	7	0	141	1	1	9	31	5	0	45	2	3	459	
<b>% Approach</b>	6.7%	83.5%	9.8%	0.0%	0.0%	0.0%	0.0%	12.2%	55.1%	28.6%	0.0%	0.0%	0.0%	0.0%	11.3%	83.7%	5.0%	0.0%	0.0%	0.0%	0.0%	20.0%	65.9%	11.1%	0.0%	0.0%	0.0%	0.0%	0.0%	
<b>% Total</b>	3.3%	40.7%	4.8%	0.0%	48.8%	0.0%	0.0%	1.3%	5.9%	3.1%	0.0%	10.7%	0.0%	0.0%	3.5%	25.7%	1.5%	0.0%	30.7%	0.0%	0.0%	2.0%	6.8%	1.1%	0.0%	9.8%	0.0%	0.0%	0.0%	
<b>PHF</b>	0.536	0.866	0.611	0.000	0.862	0.000	0.000	0.750	0.675	0.583	0.000	0.721	0.000	0.000	0.800	0.797	0.583	0.000	0.783	0.000	0.000	0.450	0.646	0.417	0.000	0.563	0.000	0.000	0.781	
<b>Lights</b>	15	174	22	0	211	0	0	6	27	14	0	47	0	0	16	111	6	0	133	0	0	9	31	5	0	45	0	0	436	
<b>% Lights</b>	100.0%	93.0%	100.0%	0.0%	94.2%	0.0%	0.0%	100.0%	100.0%	100.0%	0.0%	95.9%	0.0%	0.0%	100.0%	94.1%	85.7%	0.0%	94.3%	0.0%	0.0%	100.0%	100.0%	100.0%	0.0%	100.0%	0.0%	0.0%	95.0%	
<b>Trucks</b>	0	0	0	0	0	0	0	0	0	0	0	0	0	0	0	0	0	0	0	0	0	0	0	0	0	0	0	0	0	
<b>% Trucks</b>	0.0%	0.0%	0.0%	0.0%	0.0%	0.0%	0.0%	0.0%	0.0%	0.0%	0.0%	0.0%	0.0%	0.0%	0.0%	0.0%	0.0%	0.0%	0.0%	0.0%	0.0%	0.0%	0.0%	0.0%	0.0%	0.0%	0.0%	0.0%	0.0%	
<b>Buses</b>	0	12	0	0	12	0	0	0	0	0	0	0	0	0	0	7	1	0	8	0	0	0	0	0	0	0	0	0	20	
<b>% Buses</b>	0.0%	6.4%	0.0%	0.0%	0.0%	0.0%	0.0%	0.0%	0.0%	0.0%	0.0%	0.0%	0.0%	0.0%	0.0%	5.9%	14.3%	0.0%	0.0%	0.0%	0.0%	0.0%	0.0%	0.0%	0.0%	0.0%	0.0%	0.0%	4.4%	
<b>Pedestrians</b>	0	0	0	0	0	2	2	0	0	0	0	0	0	0	0	0	0	0	0	1	1	0	0	0	0	0	0	2	3	
<b>% Pedestrians</b>	0.0%	0.0%	0.0%	0.0%	0.0%	100.0%	100.0%	0.0%	0.0%	0.0%	0.0%	0.0%	0.0%	0.0%	0.0%	0.0%	0.0%	0.0%	0.0%	0.0%	100.0%	100.0%	0.0%	0.0%	0.0%	0.0%	0.0%	100.0%	100.0%	0.0%
<b>Bicycles on Crosswalk</b>	0	0	0	0	0	0	0	0	0	0	0	0	0	0	0	0	0	0	0	0	0	0	0	0	0	0	0	0	0	
<b>% Bicycles on Crosswalk</b>	0.0%	0.0%	0.0%	0.0%	0.0%	0.0%	0.0%	0.0%	0.0%	0.0%	0.0%	0.0%	0.0%	0.0%	0.0%	0.0%	0.0%	0.0%	0.0%	0.0%	0.0%	0.0%	0.0%	0.0%	0.0%	0.0%	0.0%	0.0%	0.0%	

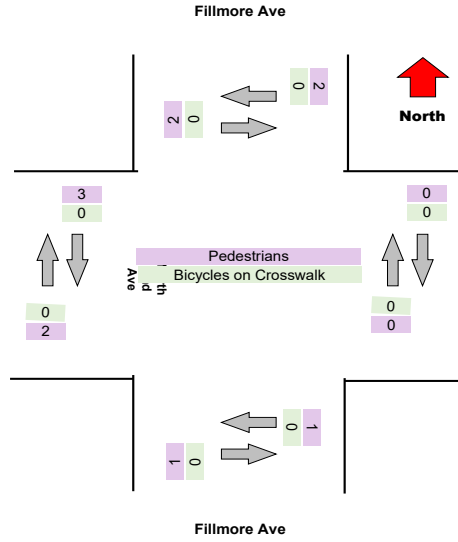
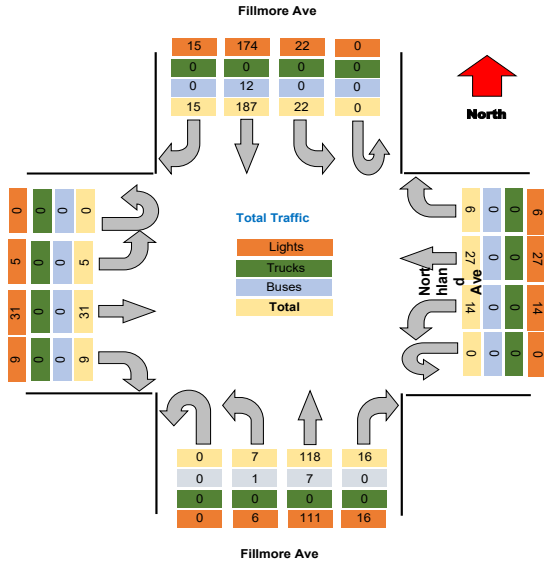

Project : VBH Malta NY  
Site : Site 4  
Location : 42.948550, -73.790036

TSTData.com

Survey Date : 2021-04-28, Wednesday

### Turning Movement Peak Hour Data (PM)

4:45:00 PM

Leg Direction	Fillmore Ave						Northland Ave						Fillmore Ave						Northland Ave						Total			
	Southbound			Westbound			Northbound			Eastbound			Northbound			Eastbound												
Start Time	Right	Thru	Left	U-Turn	App Total	Peds CW	Peds CCW	Right	Thru	Left	U-Turn	App Total	Peds CW	Peds CCW	Right	Thru	Left	U-Turn	App Total	Peds CW	Peds CCW	Right	Thru	Left	U-Turn	App Total	Peds CW	Peds CCW
4:45:00 PM	7	69	7	0	83	1	0	7	13	9	0	29	0	1	2	61	3	0	66	0	0	5	7	2	0	14	0	1
5:00:00 PM	5	69	6	0	80	0	0	3	9	15	0	27	0	0	6	77	1	0	84	1	0	7	10	1	0	18	2	1
5:15:00 PM	3	71	7	0	81	0	1	3	8	9	0	20	1	0	8	70	7	0	85	0	2	4	10	1	0	15	0	1
5:30:00 PM	2	60	3	0	65	1	0	3	5	12	0	20	0	0	4	63	3	0	70	0	0	5	5	0	0	10	1	0
<b>Grand Total</b>	<b>17</b>	<b>269</b>	<b>23</b>	<b>0</b>	<b>309</b>	<b>2</b>	<b>0</b>	<b>16</b>	<b>35</b>	<b>45</b>	<b>0</b>	<b>96</b>	<b>1</b>	<b>1</b>	<b>20</b>	<b>271</b>	<b>14</b>	<b>0</b>	<b>305</b>	<b>1</b>	<b>2</b>	<b>21</b>	<b>32</b>	<b>4</b>	<b>0</b>	<b>57</b>	<b>3</b>	<b>3</b>
% Approach	5.5%	87.1%	7.4%	0.0%	0.0%	0.0%	0.0%	16.7%	36.5%	46.9%	0.0%	0.0%	0.0%	0.0%	6.6%	88.9%	4.6%	0.0%	0.0%	0.0%	0.0%	36.8%	56.1%	7.0%	0.0%	0.0%	0.0%	0.0%
% Total	2.2%	35.1%	3.0%	0.0%	40.3%	0.0%	0.0%	2.1%	4.6%	5.9%	0.0%	12.5%	0.0%	0.0%	2.6%	35.3%	1.8%	0.0%	39.8%	0.0%	0.0%	2.7%	4.2%	0.5%	0.0%	7.4%	0.0%	0.0%
PHF	0.607	0.947	0.821	0.000	0.931	0.000	0.000	0.571	0.673	0.750	0.000	0.828	0.000	0.000	0.625	0.880	0.500	0.000	0.897	0.000	0.000	0.750	0.800	0.500	0.000	0.792	0.000	0.000
Lights	17	264	23	0	304	0	0	16	35	45	0	96	0	0	20	267	14	0	301	0	0	20	32	4	0	56	0	0
% Lights	100.0%	98.1%	100.0%	0.0%	98.4%	0.0%	0.0%	100.0%	100.0%	100.0%	0.0%	100.0%	0.0%	0.0%	100.0%	98.5%	100.0%	0.0%	98.7%	0.0%	0.0%	95.2%	100.0%	100.0%	0.0%	98.2%	0.0%	0.0%
Trucks	0	0	0	0	0	0	0	0	0	0	0	0	0	0	0	1	0	0	1	0	0	0	0	0	0	0	0	0
% Trucks	0.0%	0.0%	0.0%	0.0%	0.0%	0.0%	0.0%	0.0%	0.0%	0.0%	0.0%	0.0%	0.0%	0.0%	0.0%	0.4%	0.0%	0.0%	0.3%	0.0%	0.0%	0.0%	0.0%	0.0%	0.0%	0.0%	0.0%	0.0%
Buses	0	5	0	0	5	0	0	0	0	0	0	0	0	0	0	3	0	0	3	0	0	1	0	0	0	1	0	0
% Buses	0.0%	1.9%	0.0%	0.0%	0.0%	0.0%	0.0%	0.0%	0.0%	0.0%	0.0%	0.0%	0.0%	0.0%	0.0%	1.1%	0.0%	0.0%	0.0%	0.0%	0.0%	4.8%	0.0%	0.0%	0.0%	0.0%	0.0%	0.0%
Pedestrians	0	0	0	0	0	2	1	0	0	0	0	1	1	1	0	0	0	0	0	1	2	0	0	0	0	0	3	3
% Pedestrians	0.0%	0.0%	0.0%	0.0%	0.0%	100.0%	50.0%	0.0%	0.0%	0.0%	0.0%	0.0%	100.0%	100.0%	0.0%	0.0%	0.0%	0.0%	0.0%	0.0%	100.0%	0.0%	0.0%	0.0%	0.0%	0.0%	0.0%	100.0%
Bicycles on Crosswalk	0	0	0	0	0	0	1	0	0	0	0	0	0	0	0	0	0	0	0	0	0	0	0	0	0	0	0	0
% Bicycles on Crosswalk	0.0%	0.0%	0.0%	0.0%	0.0%	0.0%	50.0%	0.0%	0.0%	0.0%	0.0%	0.0%	0.0%	0.0%	0.0%	0.0%	0.0%	0.0%	0.0%	0.0%	0.0%	0.0%	0.0%	0.0%	0.0%	0.0%	0.0%	0.0%

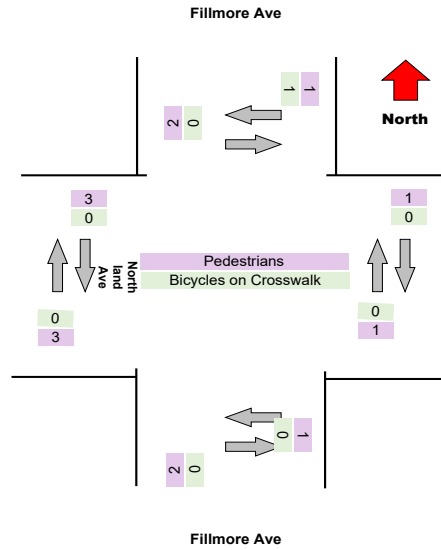
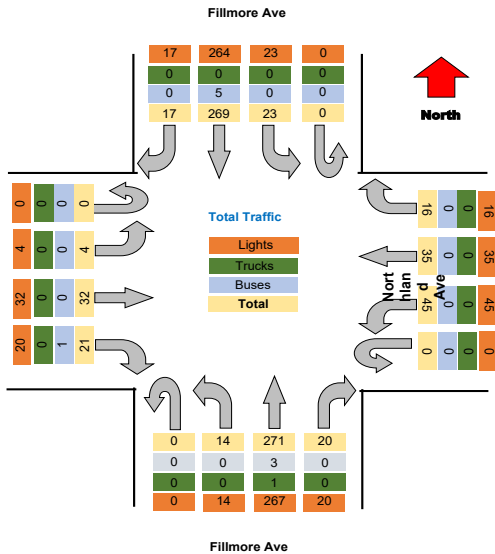



Project : VBH Malta NY  
 Site : Site 4  
 Location : 42.948550, -73.790036  
 Survey Date : 2021-04-28, Wednesday

### Turning Movement Data Plot

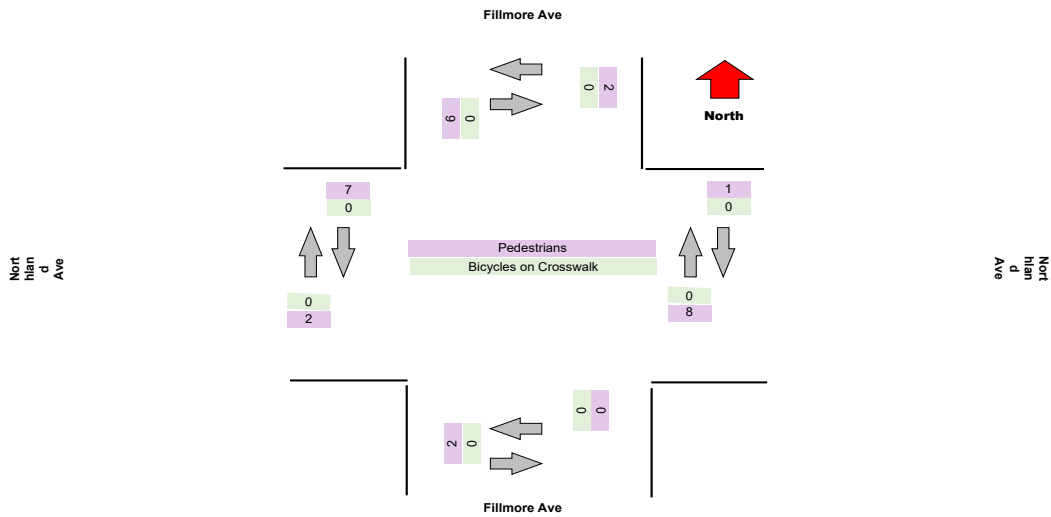
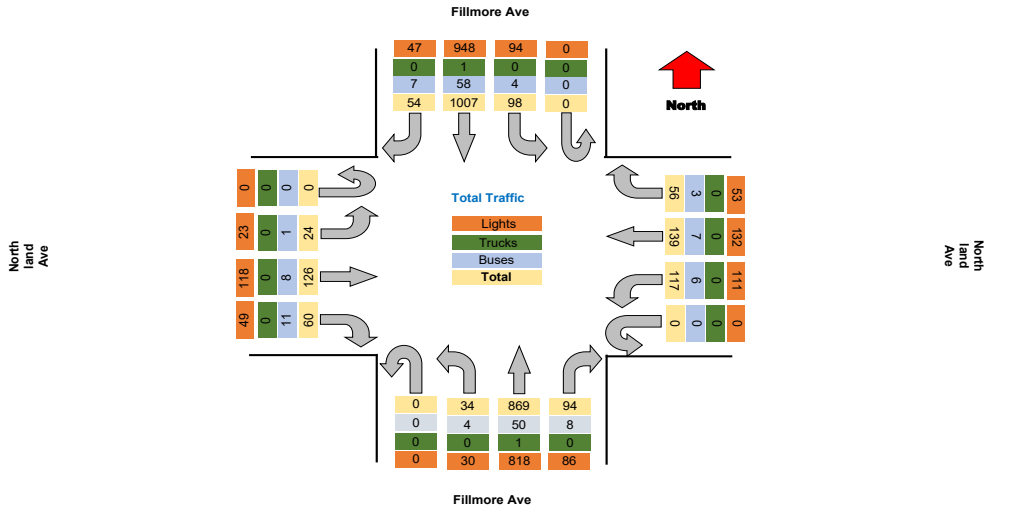



Project : VBH Malta NY  
Site : Site 4  
Location : 42.948550, -73.790036

TSTData.com

Survey Date : 2021-04-28, Wednesday

### Turning Movement Peak Hour Data (AM)

7:30:00 AM

Leg Direction	Fillmore Ave						Northland Ave						Fillmore Ave						Northland Ave						Total			
	Southbound			Westbound			Northbound			Eastbound			Northbound			Eastbound												
Start Time	Right	Thru	Left	U-Turn	App Total	Peds CW	Peds CCW	Right	Thru	Left	U-Turn	App Total	Peds CW	Peds CCW	Right	Thru	Left	U-Turn	App Total	Peds CW	Peds CCW	Right	Thru	Left	U-Turn	App Total	Peds CW	Peds CCW
7:30:00 AM	2	56	9	0	67	1	0	0	11	6	0	17	0	3	8	41	3	0	55	0	0	4	13	2	0	19	1	0
7:45:00 AM	1	88	14	0	103	0	0	1	8	6	0	15	0	1	6	74	2	0	83	0	0	3	11	4	0	18	0	0
8:00:00 AM	2	87	7	0	96	1	0	3	4	7	0	14	0	1	5	59	0	0	65	0	0	4	5	0	0	9	0	0
8:15:00 AM	3	67	7	0	77	0	0	2	6	7	0	15	0	0	10	43	3	0	56	0	0	2	5	0	0	7	0	0
<b>Grand Total</b>	<b>8</b>	<b>298</b>	<b>37</b>	<b>0</b>	<b>343</b>	<b>2</b>	<b>0</b>	<b>6</b>	<b>29</b>	<b>26</b>	<b>0</b>	<b>51</b>	<b>0</b>	<b>5</b>	<b>29</b>	<b>217</b>	<b>8</b>	<b>0</b>	<b>299</b>	<b>0</b>	<b>0</b>	<b>13</b>	<b>34</b>	<b>6</b>	<b>0</b>	<b>53</b>	<b>1</b>	<b>0</b>
<b>% Approach</b>	2.3%	86.0%	10.8%	0.0%	0.0%	0.0%	0.0%	9.8%	47.5%	42.6%	0.0%	0.0%	0.0%	0.0%	11.2%	83.6%	3.1%	0.0%	0.0%	0.0%	0.0%	24.5%	64.2%	11.3%	0.0%	0.0%	0.0%	0.0%
<b>% Total</b>	1.1%	41.6%	5.2%	0.0%	47.9%	0.0%	0.0%	0.8%	4.1%	3.6%	0.0%	8.5%	0.0%	0.0%	4.1%	30.3%	1.1%	0.0%	36.2%	0.0%	0.0%	1.8%	4.7%	0.8%	0.0%	7.4%	0.0%	0.0%
<b>PHF</b>	0.667	0.847	0.661	0.000	0.833	0.000	0.000	0.500	0.659	0.929	0.000	0.897	0.000	0.000	0.725	0.733	0.667	0.000	0.780	0.000	0.000	0.813	0.654	0.375	0.000	0.697	0.000	0.000
<b>Lights</b>	7	279	34	0	320	0	0	6	25	26	0	57	0	0	27	199	8	0	234	0	0	11	33	5	0	49	0	0
<b>% Lights</b>	87.5%	93.6%	91.9%	0.0%	93.3%	0.0%	0.0%	100.0%	86.2%	100.0%	0.0%	93.4%	0.0%	0.0%	93.1%	91.7%	100.0%	0.0%	90.3%	0.0%	0.0%	84.6%	97.1%	83.3%	0.0%	92.5%	0.0%	0.0%
<b>Trucks</b>	0	0	0	0	0	0	0	0	0	0	0	0	0	0	0	0	0	0	0	0	0	0	0	0	0	0	0	0
<b>% Trucks</b>	0.0%	0.0%	0.0%	0.0%	0.0%	0.0%	0.0%	0.0%	0.0%	0.0%	0.0%	0.0%	0.0%	0.0%	0.0%	0.0%	0.0%	0.0%	0.0%	0.0%	0.0%	0.0%	0.0%	0.0%	0.0%	0.0%	0.0%	0.0%
<b>Buses</b>	1	19	3	0	23	0	0	0	4	0	0	4	0	0	2	18	0	0	20	0	0	2	1	1	0	4	0	0
<b>% Buses</b>	12.5%	6.4%	8.1%	0.0%	6.7%	0.0%	0.0%	0.0%	13.8%	0.0%	0.0%	7.8%	0.0%	0.0%	6.9%	8.3%	0.0%	0.0%	6.7%	0.0%	0.0%	15.4%	2.9%	16.7%	0.0%	7.4%	0.0%	0.0%
<b>Pedestrians</b>	0	0	0	0	0	2	0	0	0	0	0	0	5	0	0	0	0	0	0	0	0	0	0	0	0	0	1	0
<b>% Pedestrians</b>	0.0%	0.0%	0.0%	0.0%	0.0%	100.0%	0.0%	0.0%	0.0%	0.0%	0.0%	0.0%	100.0%	0.0%	0.0%	0.0%	0.0%	0.0%	0.0%	0.0%	0.0%	0.0%	0.0%	0.0%	0.0%	0.0%	100.0%	0.0%
<b>Bicycles on Crosswalk</b>	0	0	0	0	0	0	0	0	0	0	0	0	0	0	0	0	0	0	0	0	0	0	0	0	0	0	0	0
<b>% Bicycles on Crosswalk</b>	0.0%	0.0%	0.0%	0.0%	0.0%	0.0%	0.0%	0.0%	0.0%	0.0%	0.0%	0.0%	0.0%	0.0%	0.0%	0.0%	0.0%	0.0%	0.0%	0.0%	0.0%	0.0%	0.0%	0.0%	0.0%	0.0%	0.0%	0.0%

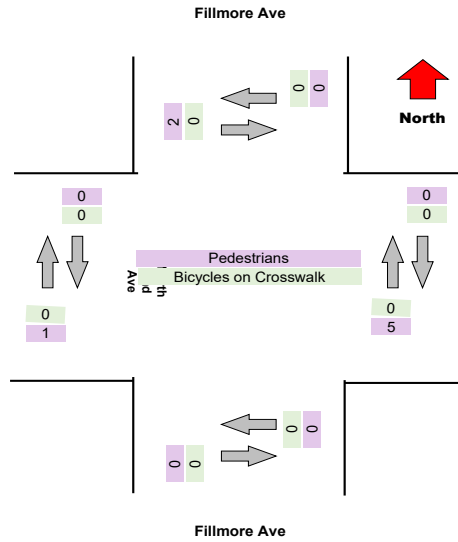
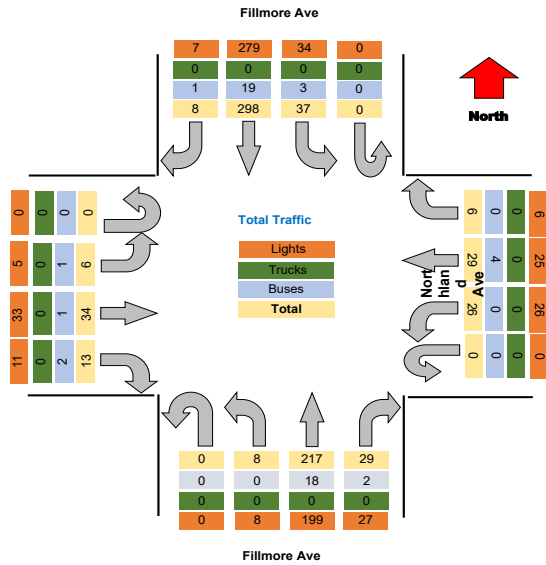

Project : VBH Malta NY  
Site : Site 4  
Location : 42.948550, -73.790036

TSTData.com

Survey Date : 2021-04-28, Wednesday

### Turning Movement Peak Hour Data (PM)

4:45:00 PM

Leg Direction	Fillmore Ave				Northland Ave				Fillmore Ave				Northland Ave				Total												
	Southbound				Westbound				Northbound				Eastbound																
	Right	Thru	Left	U-Turn	App Total	Peds CW	Peds CCW	Right	Thru	Left	U-Turn	App Total	Peds CW	Peds CCW	Right	Thru		Left	U-Turn	App Total	Peds CW	Peds CCW							
4:45:00 PM	6	67	1	0	74	0	0	8	8	7	0	23	0	0	5	86	5	0	96	0	0	7	4	3	0	14	0	1	207
5:00:00 PM	1	72	3	0	76	0	0	3	12	9	0	24	0	0	9	65	3	0	77	0	0	5	4	3	0	12	0	0	189
5:15:00 PM	3	78	2	0	83	3	0	11	8	6	0	25	0	1	4	58	5	0	67	0	1	1	7	1	0	8	0	1	183
5:30:00 PM	4	67	5	0	76	0	0	5	12	2	0	19	0	0	4	55	0	0	59	0	0	8	7	1	0	16	0	0	160
Grand Total	14	284	11	0	309	3	0	27	40	24	0	91	0	1	22	274	13	0	309	0	1	21	22	7	0	50	0	2	759
% Approach	4.5%	91.9%	3.6%	0.0%	0.0%	0.0%	0.0%	29.7%	44.0%	26.4%	0.0%	0.0%	0.0%	0.0%	7.1%	88.7%	4.2%	0.0%	0.0%	0.0%	0.0%	42.0%	44.0%	14.0%	0.0%	0.0%	0.0%	0.0%	0.0%
% Total	1.8%	37.4%	1.4%	0.0%	40.7%	0.0%	0.0%	3.6%	5.3%	3.2%	0.0%	12.0%	0.0%	0.0%	2.9%	36.1%	1.7%	0.0%	40.7%	0.0%	0.0%	2.8%	2.9%	0.9%	0.0%	6.6%	0.0%	0.0%	0.0%
PHF	0.583	0.910	0.550	0.000	0.931	0.000	0.000	0.614	0.833	0.667	0.000	0.910	0.000	0.000	0.611	0.797	0.650	0.000	0.805	0.000	0.000	0.656	0.786	0.583	0.000	0.781	0.000	0.000	0.917
Lights	14	276	11	0	301	0	0	25	40	24	0	89	0	0	21	264	13	0	298	0	0	17	22	7	0	46	0	0	734
% Lights	100.0%	97.2%	100.0%	0.0%	97.4%	0.0%	0.0%	92.6%	100.0%	100.0%	0.0%	97.8%	0.0%	0.0%	95.5%	96.4%	100.0%	0.0%	96.4%	0.0%	0.0%	81.0%	100.0%	100.0%	0.0%	92.0%	0.0%	0.0%	96.7%
Trucks	0	0	0	0	0	0	0	0	0	0	0	0	0	0	0	0	0	0	0	0	0	0	0	0	0	0	0	0	0
% Trucks	0.0%	0.0%	0.0%	0.0%	0.0%	0.0%	0.0%	0.0%	0.0%	0.0%	0.0%	0.0%	0.0%	0.0%	0.0%	0.0%	0.0%	0.0%	0.0%	0.0%	0.0%	0.0%	0.0%	0.0%	0.0%	0.0%	0.0%	0.0%	0.0%
Buses	0	8	0	0	8	0	0	2	0	0	0	2	0	0	1	10	0	0	11	0	0	4	0	0	0	4	0	0	25
% Buses	0.0%	2.8%	0.0%	0.0%	0.0%	0.0%	0.0%	7.4%	0.0%	0.0%	0.0%	0.0%	0.0%	0.0%	4.5%	3.6%	0.0%	0.0%	0.0%	0.0%	0.0%	19.0%	0.0%	0.0%	0.0%	0.0%	0.0%	0.0%	3.3%
Pedestrians	0	0	0	0	0	3	0	0	0	0	0	0	1	0	0	0	0	0	0	0	1	0	0	0	0	0	0	2	0
% Pedestrians	0.0%	0.0%	0.0%	0.0%	0.0%	100.0%	0.0%	0.0%	0.0%	0.0%	0.0%	0.0%	100.0%	0.0%	0.0%	0.0%	0.0%	0.0%	0.0%	0.0%	0.0%	0.0%	0.0%	0.0%	0.0%	0.0%	0.0%	100.0%	0.0%
Bicycles on Crosswalk	0	0	0	0	0	0	0	0	0	0	0	0	0	0	0	0	0	0	0	0	0	0	0	0	0	0	0	0	0
% Bicycles on Crosswalk	0.0%	0.0%	0.0%	0.0%	0.0%	0.0%	0.0%	0.0%	0.0%	0.0%	0.0%	0.0%	0.0%	0.0%	0.0%	0.0%	0.0%	0.0%	0.0%	0.0%	0.0%	0.0%	0.0%	0.0%	0.0%	0.0%	0.0%	0.0%	0.0%

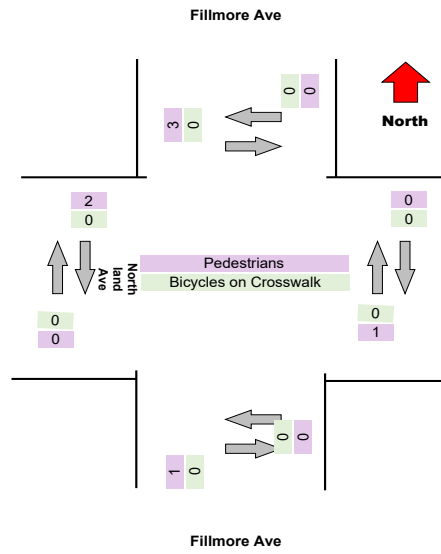
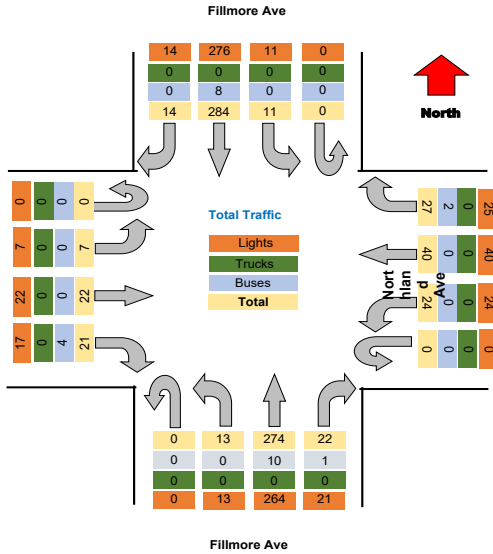

Project : VBH Malta NY  
 Site : Site 4  
 Location : 42.948550, -73.790036

TSTData.com

Survey Date : 2021-04-28, Wednesday

Project	LaBella
Project Code	LaBella
Site Name	25
Legs and Movements	All Processed Legs & Move
Bin Size	15 minutes
Survey Date	2021-11-04, Thursday
Location	25
Latitude and Longitude	42.914640, -78.839098

	Start	End	PHF
Forced Peak AM	2021/11/04 07:30:00	2021/11/04 08:30:00	0.96
Forced Peak PM	2021/11/04 16:30:00	2021/11/04 17:30:00	0.97
AM Peak	2021/11/04 07:30:00	2021/11/04 08:30:00	0.96
PM Peak	2021/11/04 16:45:00	2021/11/04 17:45:00	0.95

### Turning Movement Data

Leg Direction	Fillmore Ave								Northland Ave								Fillmore Ave								Northland Ave								Total
	Southbound				Westbound				Northbound				Eastbound				Southbound				Westbound												
	Right	Thru	Left	U-Turn	App Total	Peds CV	Peds CCV	Peds	Right	Thru	Left	U-Turn	App Total	Peds CV	Peds CCV	Peds	Right	Thru	Left	U-Turn	App Total	Peds CV	Peds CCV	Peds	Right	Thru	Left	U-Turn	App Total	Peds CV	Peds CCV	Peds	
6:30:00 AM	2	19	3	0	<b>24</b>	0	1	2	2	0	0	<b>5</b>	0	0	0	3	16	1	0	<b>20</b>	0	0	0	1	6	1	0	<b>8</b>	0	1	0	57	
6:45:00 AM	0	26	4	0	<b>40</b>	0	0	1	3	2	0	<b>6</b>	0	0	0	1	22	4	0	<b>27</b>	0	0	0	3	7	1	0	<b>11</b>	1	1	0	84	
Hourly Total	2	55	7	0	<b>64</b>	0	1	3	5	2	0	<b>11</b>	0	0	0	4	38	5	0	<b>47</b>	0	0	0	4	13	2	0	<b>19</b>	1	1	0	141	
7:00:00 AM	1	30	7	0	<b>38</b>	1	0	0	8	1	0	<b>9</b>	0	0	0	3	23	2	0	<b>28</b>	0	0	0	1	7	0	0	<b>8</b>	0	0	0	83	
7:15:00 AM	3	33	7	0	<b>43</b>	0	1	0	7	4	0	<b>12</b>	0	0	0	6	31	3	0	<b>40</b>	0	0	0	2	9	2	0	<b>13</b>	0	0	0	108	
7:30:00 AM	5	67	10	0	<b>82</b>	1	0	2	11	4	0	<b>17</b>	0	0	0	5	37	2	0	<b>44</b>	0	0	0	4	11	1	0	<b>16</b>	0	0	0	159	
7:45:00 AM	2	75	13	0	<b>90</b>	1	0	2	8	5	0	<b>15</b>	0	1	0	10	50	1	0	<b>62</b>	0	0	0	2	10	1	0	<b>13</b>	0	0	0	180	
Hourly Total	11	205	37	0	<b>253</b>	3	1	4	34	14	0	<b>53</b>	0	1	0	24	141	8	0	<b>174</b>	0	0	0	9	37	4	0	<b>50</b>	0	0	0	530	
8:00:00 AM	1	79	9	0	<b>89</b>	1	0	0	11	5	0	<b>16</b>	0	0	0	9	52	0	0	<b>61</b>	0	1	0	4	5	0	0	<b>9</b>	0	1	0	175	
8:15:00 AM	0	78	3	0	<b>81</b>	0	1	2	5	4	0	<b>12</b>	0	2	0	6	59	0	0	<b>67</b>	0	0	0	3	10	3	0	<b>16</b>	0	0	0	176	
Hourly Total	1	157	12	0	<b>170</b>	1	1	2	16	9	0	<b>28</b>	0	2	0	15	111	0	0	<b>128</b>	0	1	0	7	15	3	0	<b>25</b>	0	1	0	351	
4:00:00 PM	13	84	6	0	<b>103</b>	0	0	8	15	15	0	<b>38</b>	0	0	0	9	72	6	0	<b>87</b>	0	0	0	4	11	5	0	<b>20</b>	0	0	0	248	
4:15:00 PM	2	97	8	0	<b>107</b>	0	0	7	3	7	0	<b>17</b>	0	0	0	9	55	2	0	<b>66</b>	1	0	0	4	9	3	0	<b>16</b>	0	2	0	206	
4:30:00 PM	5	78	7	0	<b>90</b>	0	0	1	8	14	0	<b>23</b>	0	0	0	8	59	4	0	<b>71</b>	0	0	0	11	14	2	0	<b>27</b>	0	0	0	211	
4:45:00 PM	6	86	3	0	<b>95</b>	0	0	4	14	8	0	<b>26</b>	0	0	0	10	80	1	0	<b>91</b>	0	0	0	5	6	1	0	<b>12</b>	1	0	0	224	
Hourly Total	26	345	24	0	<b>395</b>	0	0	20	40	44	0	<b>104</b>	0	0	0	36	296	13	0	<b>315</b>	1	0	0	24	40	11	0	<b>75</b>	1	2	0	859	
5:00:00 PM	5	74	6	0	<b>85</b>	0	0	3	11	13	0	<b>27</b>	0	0	0	8	80	3	0	<b>91</b>	0	0	0	7	7	0	0	<b>14</b>	2	0	0	217	
5:15:00 PM	3	85	9	0	<b>97</b>	0	0	7	13	6	0	<b>26</b>	0	0	0	5	73	4	0	<b>82</b>	0	0	0	2	5	2	0	<b>9</b>	0	1	0	214	
5:30:00 PM	5	70	7	0	<b>82</b>	0	0	3	12	15	0	<b>30</b>	0	0	0	6	62	3	0	<b>71</b>	0	1	0	5	7	1	0	<b>13</b>	0	0	0	196	
5:45:00 PM	6	71	2	0	<b>79</b>	0	0	2	4	5	0	<b>11</b>	0	0	0	2	52	4	0	<b>58</b>	0	0	0	4	2	0	0	<b>6</b>	0	1	0	154	
Hourly Total	19	300	24	0	<b>343</b>	0	0	15	40	39	0	<b>94</b>	0	0	0	21	267	14	0	<b>302</b>	0	1	0	18	21	3	0	<b>42</b>	2	2	0	781	
Grand Total	59	1062	104	0	<b>1225</b>	4	3	44	135	108	0	<b>290</b>	2	3	0	100	823	40	0	<b>966</b>	3	2	0	62	126	23	0	<b>211</b>	4	6	0	2692	
% Approach	4.6%	86.7%	8.5%	0.0%	0.0%	0.0%	0.0%	15.2%	46.6%	37.2%	0.0%	0.0%	0.0%	0.0%	0.0%	10.4%	85.2%	4.1%	0.0%	0.0%	0.0%	0.0%	0.0%	29.4%	59.7%	10.9%	0.0%	0.0%	0.0%	0.0%	0.0%	0.0%	
% Total	2.2%	39.5%	3.9%	0.0%	45.5%	0.0%	0.0%	1.6%	5.0%	4.0%	0.0%	10.8%	0.0%	0.0%	0.0%	3.7%	30.6%	1.5%	0.0%	35.9%	0.0%	0.0%	0.0%	2.3%	4.7%	0.9%	0.0%	7.8%	0.0%	0.0%	0.0%	0.0%	
Lights	54	992	96	0	1142	0	0	42	129	104	0	275	0	0	0	90	776	36	0	902	0	0	0	53	119	21	0	193	0	0	0	2512	
% Lights	91.5%	93.4%	92.3%	0.0%	93.2%	0.0%	0.0%	95.5%	95.6%	96.3%	0.0%	94.8%	0.0%	0.0%	0.0%	80.0%	84.3%	90.0%	0.0%	93.4%	0.0%	0.0%	0.0%	85.5%	94.4%	91.3%	0.0%	91.5%	0.0%	0.0%	0.0%	93.3%	
Trucks	0	2	0	0	2	0	0	0	0	0	0	0	0	0	0	0	1	0	0	1	0	0	0	0	0	0	0	0	0	0	0	3	
% Trucks	0.0%	0.2%	0.0%	0.0%	0.2%	0.0%	0.0%	0.0%	0.0%	0.0%	0.0%	0.0%	0.0%	0.0%	0.0%	0.0%	0.1%	0.0%	0.0%	0.1%	0.0%	0.0%	0.0%	0.0%	0.0%	0.0%	0.0%	0.0%	0.0%	0.0%	0.0%	0.1%	
Buses	5	68	8	0	81	0	0	2	6	4	0	12	0	0	0	10	46	4	0	60	0	0	0	9	7	2	0	18	0	0	0	171	
% Buses	8.5%	6.4%	7.7%	0.0%	0.0%	0.0%	0.0%	0.0%	4.4%	3.7%	0.0%	0.0%	0.0%	0.0%	0.0%	10.0%	5.6%	10.0%	0.0%	0.0%	0.0%	0.0%	0.0%	14.5%	5.6%	8.7%	0.0%	0.0%	0.0%	0.0%	0.0%	6.4%	
Pedestrians	0	0	0	0	0	4	3	0	0	0	0	0	2	3	0	0	0	0	0	0	3	2	0	0	0	0	0	0	4	6	0	0	
% Pedestrians	0.0%	0.0%	0.0%	0.0%	0.0%	100.0%	100.0%	0.0%	0.0%	0.0%	0.0%	0.0%	100.0%	100.0%	0.0%	0.0%	0.0%	0.0%	0.0%	0.0%	0.0%	0.0%	0.0%	0.0%	0.0%	0.0%	0.0%	100.0%	100.0%	0.0%	0.0%		
Bicycles on Crosswalk	0	0	0	0	0	0	0	0	0	0	0	0	0	0	0	0	0	0	0	0	0	0	0	0	0	0	0	0	0	0	0	0	
% Bicycles on Crosswalk	0.0%	0.0%	0.0%	0.0%	0.0%	0.0%	0.0%	0.0%	0.0%	0.0%	0.0%	0.0%	0.0%	0.0%	0.0%	0.0%	0.0%	0.0%	0.0%	0.0%	0.0%	0.0%	0.0%	0.0%	0.0%	0.0%	0.0%	0.0%	0.0%	0.0%	0.0%		

Project : VBH Malta NY  
 Site : Site 4  
 Location : 42.948550, -73.790036  
 Survey Date : 2021-04-28, Wednesday

### Turning Movement Data Plot

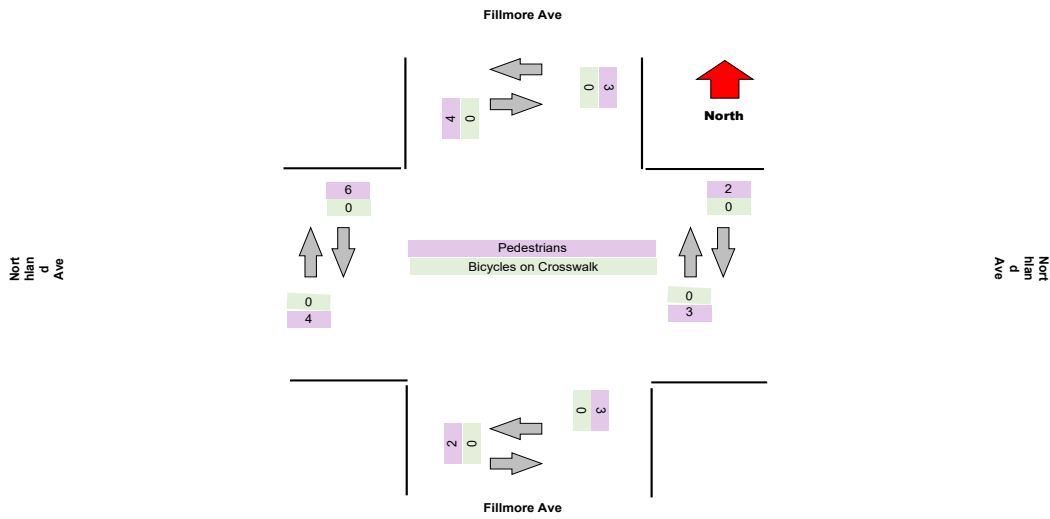
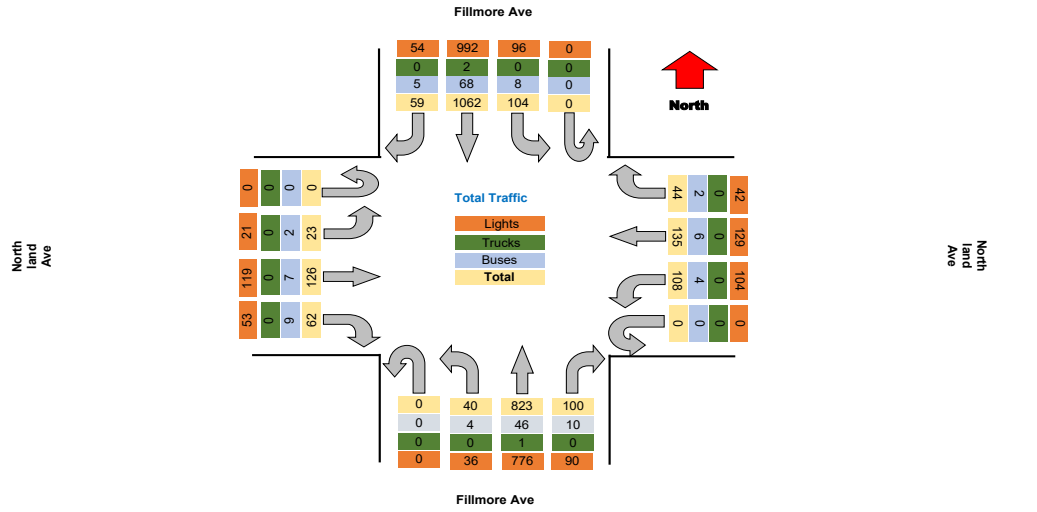

Project : VBH Malta NY  
Site : Site 4  
Location : 42.948550, -73.790036

TSTData.com

Survey Date : 2021-04-28, Wednesday

### Turning Movement Peak Hour Data (AM)

7:30:00 AM

Leg Direction	Fillmore Ave								Northland Ave								Fillmore Ave								Northland Ave								Total		
	Southbound				Westbound				Northbound				Eastbound				Northbound				Eastbound														
Start Time	Right	Thru	Left	U-Turn	App Total	Peds CW	Peds CCW		Right	Thru	Left	U-Turn	App Total	Peds CW	Peds CCW		Right	Thru	Left	U-Turn	App Total	Peds CW	Peds CCW		Right	Thru	Left	U-Turn	App Total	Peds CW	Peds CCW				
7:30:00 AM	5	67	10	0	82	1	0		2	11	4	0	17	0	0		5	37	2	0	44	0	0		4	11	1	0	16	0	0		159		
7:45:00 AM	2	75	13	0	90	1	0		2	8	5	0	15	0	1		10	50	1	0	62	0	0		2	10	1	0	13	0	0		180		
8:00:00 AM	1	79	9	0	89	1	0		0	11	5	0	16	0	0		9	52	0	0	61	0	1		4	5	0	0	9	0	0		175		
8:15:00 AM	0	78	3	0	81	0	0		2	5	4	0	12	0	2		6	58	0	0	67	0	0		3	10	3	0	16	0	0		178		
Grand Total	8	299	35	0	342	3	0		6	35	18	0	59	0	3		30	198	3	0	234	0	1		13	36	5	0	54	0	1		690		
% Approach	2.3%	87.4%	10.2%	0.0%	0.0%	0.0%	0.0%		10.0%	58.3%	30.0%	0.0%	0.0%	0.0%	0.0%		12.8%	84.6%	1.3%	0.0%	0.0%	0.0%	0.0%		24.1%	66.7%	9.3%	0.0%	0.0%	0.0%	0.0%				
% Total	1.2%	43.3%	5.1%	0.0%	48.6%	0.0%	0.0%		0.9%	5.1%	2.6%	0.0%	8.7%	0.0%	0.0%		4.3%	28.7%	0.4%	0.0%	33.9%	0.0%	0.0%		1.9%	5.2%	0.7%	0.0%	7.8%	0.0%	0.0%				
PHF	0.400	0.946	0.673	0.000	0.950	0.000	0.000		0.750	0.795	0.900	0.000	0.882	0.000	0.000		0.750	0.839	0.375	0.000	0.873	0.000	0.000		0.813	0.818	0.417	0.000	0.844	0.000	0.000		0.958		
Lights	7	279	30	0	316	0	0		5	31	18	0	54	0	0		26	181	3	0	210	0	0		11	35	4	0	50	0	0		630		
% Lights	87.5%	93.3%	85.7%	0.0%	92.4%	0.0%	0.0%		83.3%	88.6%	100.0%	0.0%	90.0%	0.0%	0.0%		86.7%	91.4%	100.0%	0.0%	89.7%	0.0%	0.0%		84.6%	97.2%	80.0%	0.0%	92.6%	0.0%	0.0%		91.3%		
Trucks	0	0	0	0	0	0	0		0	0	0	0	0	0	0		0	0	0	0	0	0	0	0		0	0	0	0	0	0	0	0		0
% Trucks	0.0%	0.0%	0.0%	0.0%	0.0%	0.0%	0.0%		0.0%	0.0%	0.0%	0.0%	0.0%	0.0%	0.0%		0.0%	0.0%	0.0%	0.0%	0.0%	0.0%	0.0%	0.0%		0.0%	0.0%	0.0%	0.0%	0.0%	0.0%	0.0%		0.0%	
Buses	1	20	5	0	26	0	0		1	4	0	0	5	0	0		4	17	0	0	21	0	0		2	1	1	0	4	0	0		56		
% Buses	12.5%	6.7%	14.3%	0.0%	0.0%	0.0%	0.0%		16.7%	11.4%	0.0%	0.0%	0.0%	0.0%	0.0%		13.3%	8.6%	0.0%	0.0%	0.0%	0.0%	0.0%		15.4%	2.8%	20.0%	0.0%	0.0%	0.0%	0.0%		8.1%		
Pedestrians	0	0	0	0	0	3	1		0	0	0	0	0	0	3		0	0	0	0	0	0	1	0		0	0	0	0	0	0	1	0		4
% Pedestrians	0.0%	0.0%	0.0%	0.0%	0.0%	100.0%	100.0%		0.0%	0.0%	0.0%	0.0%	0.0%	0.0%	100.0%		0.0%	0.0%	0.0%	0.0%	0.0%	0.0%	100.0%	0.0%		0.0%	0.0%	0.0%	0.0%	0.0%	0.0%	100.0%	0.0%		
Bicycles on Crosswalk	0	0	0	0	0	0	0		0	0	0	0	0	0	0		0	0	0	0	0	0	0	0		0	0	0	0	0	0	0	0		0
% Bicycles on Crosswalk	0.0%	0.0%	0.0%	0.0%	0.0%	0.0%	0.0%		0.0%	0.0%	0.0%	0.0%	0.0%	0.0%	0.0%		0.0%	0.0%	0.0%	0.0%	0.0%	0.0%	0.0%	0.0%		0.0%	0.0%	0.0%	0.0%	0.0%	0.0%	0.0%	0.0%		0.0%

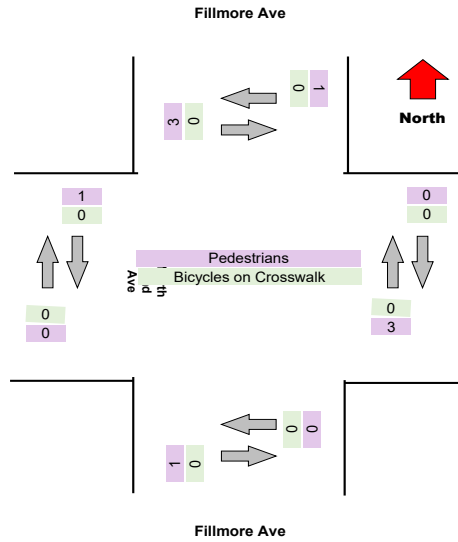
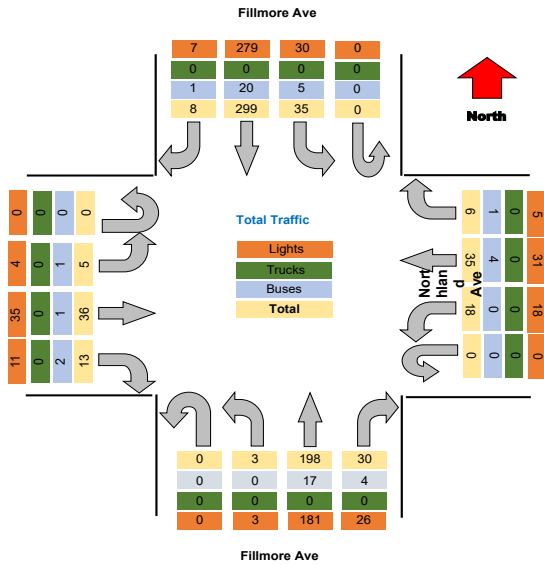

**Turning Movement Peak Hour Data (PM)**

4:45:00 PM

Leg Direction	Fillmore Ave				Northland Ave				Fillmore Ave				Northland Ave				Total												
	Southbound				Westbound				Northbound				Eastbound																
	Right	Thru	Left	U-Turn	App Total	Peds CW	Peds CCW	Right	Thru	Left	U-Turn	App Total	Peds CW	Peds CCW	Right	Thru		Left	U-Turn	App Total	Peds CW	Peds CCW							
4:45:00 PM	6	86	3	0	95	0	0	4	14	8	0	26	0	0	10	80	1	0	91	0	0	5	6	1	0	12	1	0	224
5:00:00 PM	5	74	6	0	85	0	0	3	11	13	0	27	0	0	8	80	3	0	91	0	0	7	7	0	0	14	2	0	217
5:15:00 PM	3	85	9	0	97	0	0	7	13	6	0	26	0	0	5	73	4	0	82	0	0	2	5	2	0	9	0	1	214
5:30:00 PM	5	70	7	0	82	0	0	3	12	15	0	30	0	0	6	62	3	0	71	0	1	5	7	1	0	13	0	0	196
<b>Grand Total</b>	<b>19</b>	<b>315</b>	<b>25</b>	<b>0</b>	<b>359</b>	<b>0</b>	<b>0</b>	<b>17</b>	<b>50</b>	<b>42</b>	<b>0</b>	<b>109</b>	<b>0</b>	<b>0</b>	<b>29</b>	<b>295</b>	<b>11</b>	<b>0</b>	<b>335</b>	<b>0</b>	<b>1</b>	<b>19</b>	<b>25</b>	<b>4</b>	<b>0</b>	<b>48</b>	<b>3</b>	<b>1</b>	<b>851</b>
% Approach	5.3%	87.7%	7.0%	0.0%	0.0%	0.0%	0.0%	15.6%	45.9%	38.5%	0.0%	0.0%	0.0%	0.0%	8.7%	88.1%	3.3%	0.0%	0.0%	0.0%	0.0%	39.6%	52.1%	8.3%	0.0%	0.0%	0.0%	0.0%	0.0%
% Total	2.2%	37.0%	2.9%	0.0%	42.2%	0.0%	0.0%	2.0%	5.9%	4.9%	0.0%	12.8%	0.0%	0.0%	3.4%	34.7%	1.3%	0.0%	39.4%	0.0%	0.0%	2.2%	2.9%	0.5%	0.0%	5.6%	0.0%	0.0%	0.0%
PHF	0.792	0.916	0.694	0.000	0.925	0.000	0.000	0.607	0.893	0.700	0.000	0.908	0.000	0.000	0.725	0.922	0.688	0.000	0.820	0.000	0.000	0.679	0.893	0.500	0.000	0.857	0.000	0.000	0.950
Lights	19	302	25	0	346	0	0	16	50	42	0	108	0	0	28	286	11	0	325	0	1	17	23	4	0	44	0	0	823
% Lights	100.0%	95.9%	100.0%	0.0%	96.4%	0.0%	0.0%	84.1%	100.0%	100.0%	0.0%	99.1%	0.0%	0.0%	96.6%	96.9%	100.0%	0.0%	97.0%	0.0%	0.0%	89.5%	92.0%	100.0%	0.0%	91.7%	0.0%	0.0%	96.7%
Trucks	0	1	0	0	1	0	0	0	0	0	0	0	0	0	0	1	0	0	1	0	0	0	0	0	0	0	0	0	2
% Trucks	0.0%	0.3%	0.0%	0.0%	0.3%	0.0%	0.0%	0.0%	0.0%	0.0%	0.0%	0.0%	0.0%	0.0%	0.0%	0.3%	0.0%	0.0%	0.3%	0.0%	0.0%	0.0%	0.0%	0.0%	0.0%	0.0%	0.0%	0.0%	0.2%
Buses	0	12	0	0	12	0	0	1	0	0	0	1	0	0	1	8	0	0	9	0	0	2	2	0	0	4	0	0	26
% Buses	0.0%	3.8%	0.0%	0.0%	0.0%	0.0%	0.0%	5.9%	0.0%	0.0%	0.0%	0.0%	0.0%	0.0%	3.4%	2.7%	0.0%	0.0%	0.0%	0.0%	0.0%	10.5%	8.0%	0.0%	0.0%	0.0%	0.0%	0.0%	3.1%
Pedestrians	0	0	0	0	0	0	0	0	0	0	0	0	0	0	0	0	0	1	0	0	1	0	0	0	0	0	3	1	0
% Pedestrians	0.0%	0.0%	0.0%	0.0%	0.0%	0.0%	0.0%	0.0%	0.0%	0.0%	0.0%	0.0%	0.0%	0.0%	0.0%	0.0%	0.0%	0.0%	0.0%	0.0%	0.0%	0.0%	0.0%	0.0%	0.0%	0.0%	0.0%	0.0%	0.0%
Bicycles on Crosswalk	0	0	0	0	0	0	0	0	0	0	0	0	0	0	0	0	0	0	0	0	0	0	0	0	0	0	0	0	0
% Bicycles on Crosswalk	0.0%	0.0%	0.0%	0.0%	0.0%	0.0%	0.0%	0.0%	0.0%	0.0%	0.0%	0.0%	0.0%	0.0%	0.0%	0.0%	0.0%	0.0%	0.0%	0.0%	0.0%	0.0%	0.0%	0.0%	0.0%	0.0%	0.0%	0.0%	0.0%

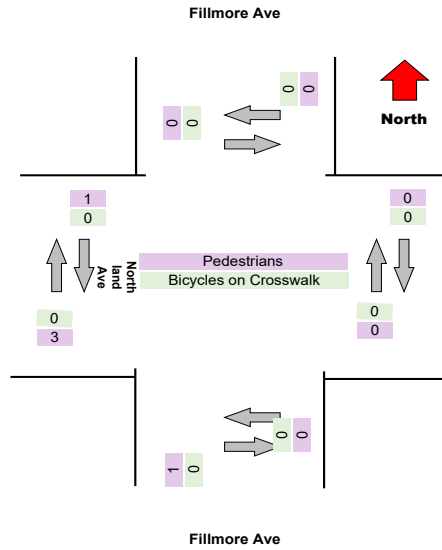
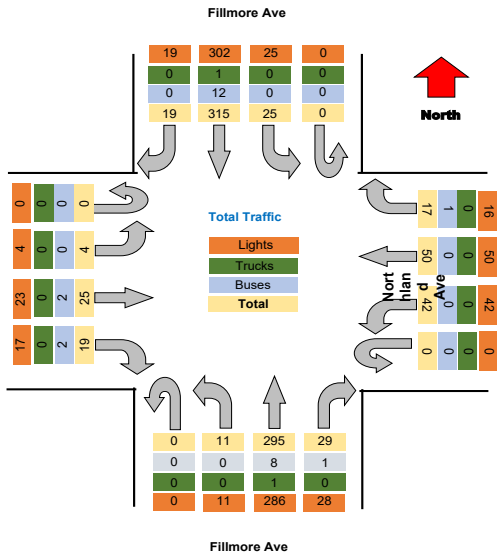



Project : VBH Malta NY  
 Site : Site 4  
 Location : 42.948550, -73.790036  
 Survey Date : 2021-04-28, Wednesday

### Turning Movement Data Plot

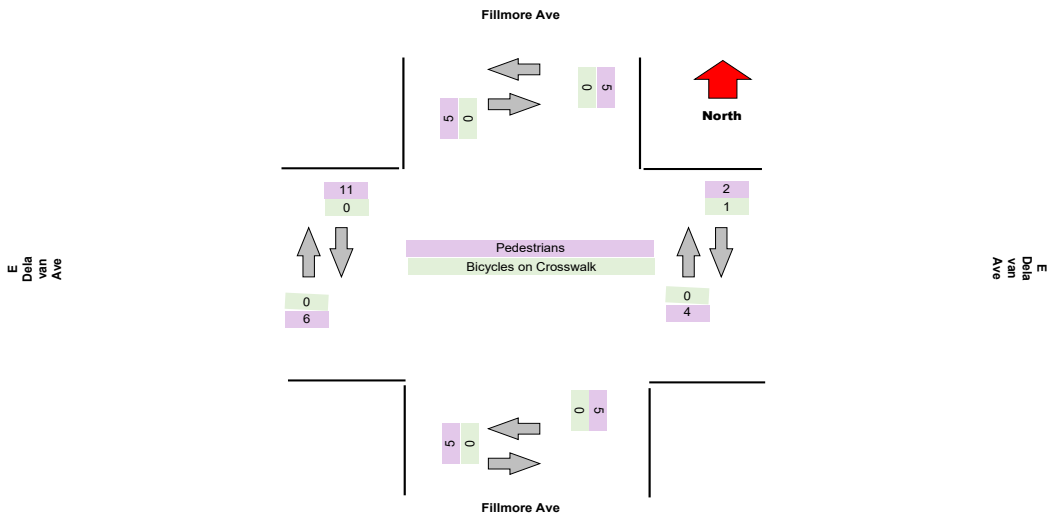
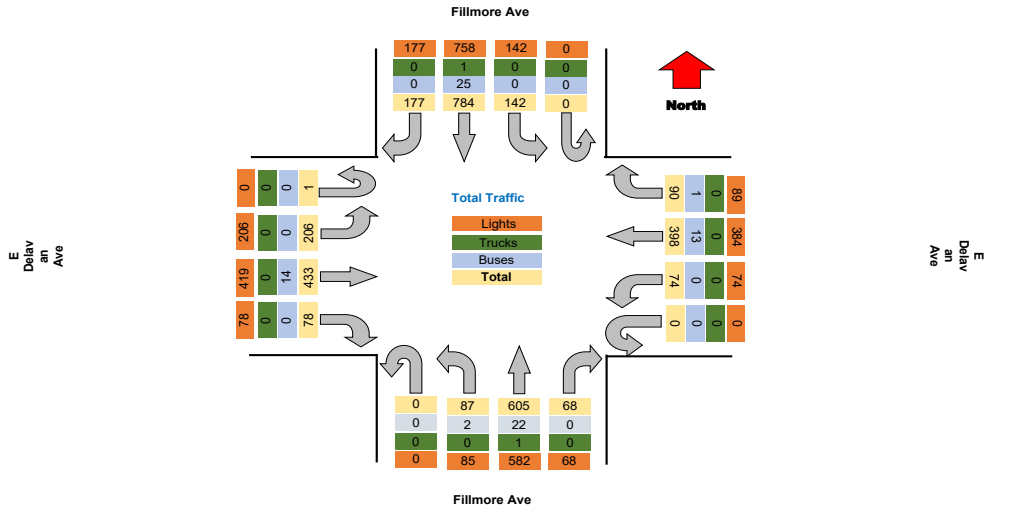



Project : VBH Malta NY  
Site : Site 4  
Location : 42.948550, -73.790036  
Survey Date : 2021-04-28, Wednesday

TSTData.com

**Turning Movement Peak Hour Data (AM)**

7:30:00 AM

Leg Direction	Fillmore Ave								E Delavan Ave								Fillmore Ave								E Delavan Ave								Total
	Southbound				Westbound				Northbound				Eastbound																				
Start Time	Right	Thru	Left	U-Turn	App Total	Peds CW	Peds CCW		Right	Thru	Left	U-Turn	App Total	Peds CW	Peds CCW		Right	Thru	Left	U-Turn	App Total	Peds CW	Peds CCW		Right	Thru	Left	U-Turn	App Total	Peds CW	Peds CCW		
7:30:00 AM	8	42	8	0	58	0	0		5	19	2	0	26	0	0		3	21	5	0	29	0	0		3	13	9	0	25	0	0		138
7:45:00 AM	9	53	11	0	73	0	0		5	21	2	0	28	1	1		1	34	4	0	41	1	1		4	26	9	0	39	0	0		181
8:00:00 AM	6	49	6	0	61	0	1		4	15	4	0	24	0	0		2	30	1	0	33	1	1		3	19	8	0	30	1	0		148
8:15:00 AM	12	46	9	0	67	0	0		3	21	3	0	27	0	0		3	17	5	0	25	0	0		3	19	12	0	34	0	0		153
<b>Grand Total</b>	35	190	34	0	259	0	1		17	76	11	0	105	1	1		9	102	15	0	128	2	2		13	77	38	0	128	1	0		620
% Approach	13.5%	73.4%	13.1%	0.0%	0.0%	0.0%	0.0%		16.2%	72.4%	10.5%	0.0%	0.0%	0.0%	0.0%		7.0%	79.7%	11.7%	0.0%	0.0%	0.0%	0.0%		10.2%	60.2%	29.7%	0.0%	0.0%	0.0%	0.0%		
% Total	5.6%	30.6%	5.5%	0.0%	41.8%	0.0%	0.0%		2.7%	12.3%	1.8%	0.0%	16.9%	0.0%	0.0%		1.5%	16.5%	2.4%	0.0%	20.6%	0.0%	0.0%		2.1%	12.4%	6.1%	0.0%	20.6%	0.0%	0.0%		
PHF	0.729	0.896	0.773	0.000	0.887	0.000	0.000		0.850	0.905	0.888	0.000	0.938	0.000	0.000		0.750	0.750	0.750	0.000	0.780	0.000	0.000		0.813	0.740	0.792	0.000	0.821	0.000	0.000		0.856
Lights	35	177	34	0	246	0	0		17	73	11	0	101	0	0		9	95	14	0	118	0	0		13	73	38	0	124	0	0		589
% Lights	100.0%	93.2%	100.0%	0.0%	95.0%	0.0%	0.0%		100.0%	96.1%	100.0%	0.0%	96.2%	0.0%	0.0%		100.0%	93.1%	93.3%	0.0%	92.2%	0.0%	0.0%		100.0%	94.8%	100.0%	0.0%	96.9%	0.0%	0.0%		95.0%
Trucks	0	0	0	0	0	0	0		0	0	0	0	0	0	0		0	0	0	0	0	0	0	0	0	0	0	0	0	0	0	0	0
% Trucks	0.0%	0.0%	0.0%	0.0%	0.0%	0.0%	0.0%		0.0%	0.0%	0.0%	0.0%	0.0%	0.0%	0.0%		0.0%	0.0%	0.0%	0.0%	0.0%	0.0%	0.0%	0.0%	0.0%	0.0%	0.0%	0.0%	0.0%	0.0%	0.0%		
Buses	0	13	0	0	13	0	0		0	3	0	0	3	0	0		0	7	1	0	8	0	0	0	0	4	0	0	4	0	0	0	28
% Buses	0.0%	6.8%	0.0%	0.0%	0.0%	0.0%	0.0%		0.0%	3.9%	0.0%	0.0%	0.0%	0.0%	0.0%		0.0%	6.9%	6.7%	0.0%	0.0%	0.0%	0.0%	0.0%	0.0%	5.2%	0.0%	0.0%	0.0%	0.0%	0.0%		
Pedestrians	0	0	0	0	0	0	1		0	0	0	0	1	1	1		0	0	0	0	2	2	2		0	0	0	0	0	1	2		0
% Pedestrians	0.0%	0.0%	0.0%	0.0%	0.0%	0.0%	100.0%		0.0%	0.0%	0.0%	0.0%	0.0%	100.0%	100.0%		0.0%	0.0%	0.0%	0.0%	0.0%	100.0%	100.0%		0.0%	0.0%	0.0%	0.0%	100.0%	100.0%	100.0%		
Bicycles on Crosswalk	0	0	0	0	0	0	0		0	0	0	0	0	0	0		0	0	0	0	0	0	0	0	0	0	0	0	0	0	0	0	0
% Bicycles on Crosswalk	0.0%	0.0%	0.0%	0.0%	0.0%	0.0%	0.0%		0.0%	0.0%	0.0%	0.0%	0.0%	0.0%	0.0%		0.0%	0.0%	0.0%	0.0%	0.0%	0.0%	0.0%	0.0%	0.0%	0.0%	0.0%	0.0%	0.0%	0.0%	0.0%		

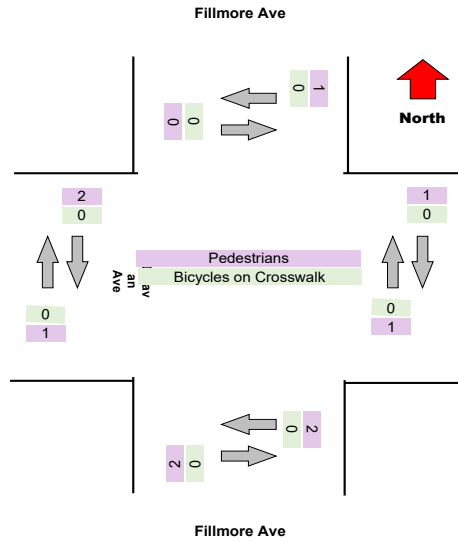
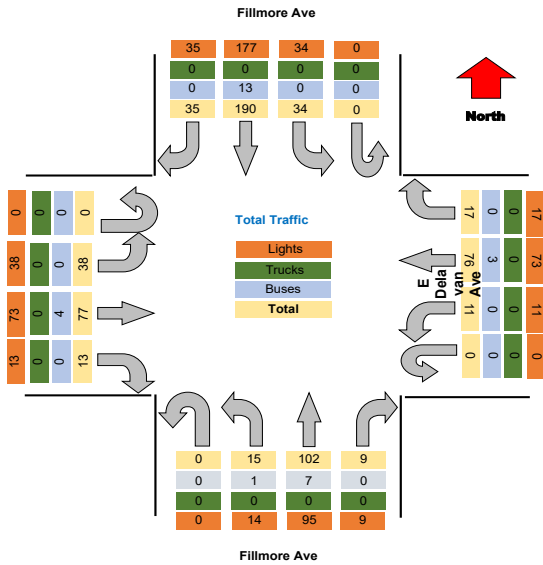

**Turning Movement Peak Hour Data (PM)**

4:45:00 PM

Leg Direction	Fillmore Ave					E Delavan Ave					Fillmore Ave					E Delavan Ave					Total	
	Southbound					Westbound					Northbound					Eastbound						
Start Time	Right	Thru	Left	U-Turn	App Total	Peds CW	Peds CCW	Right	Thru	Left	U-Turn	App Total	Peds CW	Peds CCW	Right	Thru	Left	U-Turn	App Total	Peds CW	Peds CCW	Total
4:45:00 PM	20	62	9	0	91	0	0	9	29	8	0	46	0	0	7	45	8	0	60	0	0	263
5:00:00 PM	8	65	11	0	84	0	0	11	35	9	0	55	0	0	6	66	12	0	84	1	0	279
5:15:00 PM	19	62	11	0	92	0	1	6	31	5	0	42	0	0	6	61	8	0	75	0	0	271
5:30:00 PM	12	51	9	0	72	0	0	2	31	5	0	38	0	0	5	53	8	0	66	1	0	243
<b>Grand Total</b>	<b>59</b>	<b>249</b>	<b>40</b>	<b>0</b>	<b>329</b>	<b>0</b>	<b>1</b>	<b>28</b>	<b>128</b>	<b>27</b>	<b>0</b>	<b>151</b>	<b>0</b>	<b>0</b>	<b>24</b>	<b>225</b>	<b>36</b>	<b>0</b>	<b>285</b>	<b>2</b>	<b>0</b>	<b>1056</b>
% Approach	17.4%	79.8%	11.8%	0.0%	0.0%	0.0%	0.0%	15.5%	89.6%	14.9%	0.0%	0.0%	0.0%	0.0%	8.4%	78.9%	12.6%	0.0%	0.0%	0.0%	0.0%	0.0%
% Total	5.6%	22.7%	3.8%	0.0%	32.1%	0.0%	0.0%	2.7%	11.9%	2.6%	0.0%	17.1%	0.0%	0.0%	2.3%	21.3%	3.4%	0.0%	27.0%	0.0%	0.0%	0.0%
PHF	0.738	0.923	0.909	0.000	0.921	0.000	0.000	0.636	0.900	0.750	0.000	0.823	0.000	0.000	0.857	0.852	0.750	0.000	0.848	0.000	0.000	0.946
Lights	59	236	40	0	335	0	0	27	122	27	0	176	0	0	24	221	36	0	281	0	0	1041
% Lights	100.0%	98.3%	100.0%	0.0%	98.8%	0.0%	0.0%	96.4%	96.8%	100.0%	0.0%	97.2%	0.0%	0.0%	100.0%	98.2%	100.0%	0.0%	98.6%	0.0%	0.0%	98.6%
Trucks	0	0	0	0	0	0	0	0	0	0	0	0	0	0	1	0	0	0	1	0	0	1
% Trucks	0.0%	0.0%	0.0%	0.0%	0.0%	0.0%	0.0%	0.0%	0.0%	0.0%	0.0%	0.0%	0.0%	0.0%	0.0%	0.4%	0.0%	0.0%	0.4%	0.0%	0.0%	0.1%
Buses	0	4	0	0	4	0	0	1	4	0	0	5	0	0	0	3	0	0	3	0	0	14
% Buses	0.0%	1.7%	0.0%	0.0%	0.0%	0.0%	0.0%	3.6%	3.2%	0.0%	0.0%	0.0%	0.0%	0.0%	0.0%	1.3%	0.0%	0.0%	0.0%	0.0%	0.0%	1.3%
Pedestrians	0	0	0	0	0	0	0	0	0	0	0	0	0	0	0	0	0	0	2	0	0	2
% Pedestrians	0.0%	0.0%	0.0%	0.0%	0.0%	0.0%	100.0%	0.0%	0.0%	0.0%	0.0%	0.0%	0.0%	0.0%	0.0%	0.0%	0.0%	0.0%	0.0%	0.0%	0.0%	0.0%
Bicycles on Crosswalk	0	0	0	0	0	0	0	0	0	0	0	0	0	0	0	0	0	0	0	0	0	0
% Bicycles on Crosswalk	0.0%	0.0%	0.0%	0.0%	0.0%	0.0%	0.0%	0.0%	0.0%	0.0%	0.0%	0.0%	0.0%	0.0%	0.0%	0.0%	0.0%	0.0%	0.0%	0.0%	0.0%	0.0%

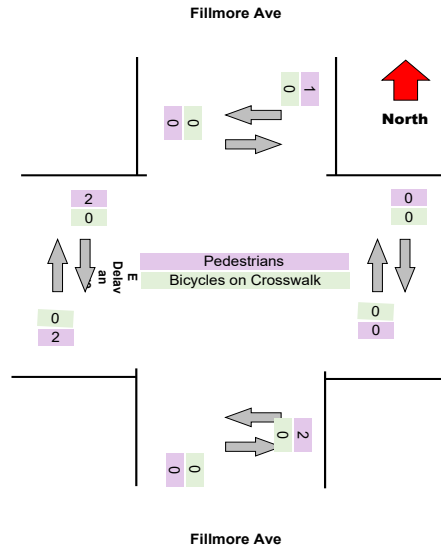
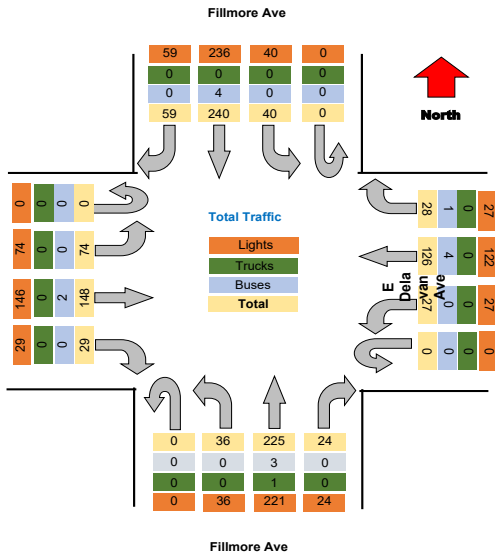



Project : VBH Malta NY  
 Site : Site 4  
 Location : 42.948550, -73.790036  
 Survey Date : 2021-04-28, Wednesday

### Turning Movement Data Plot

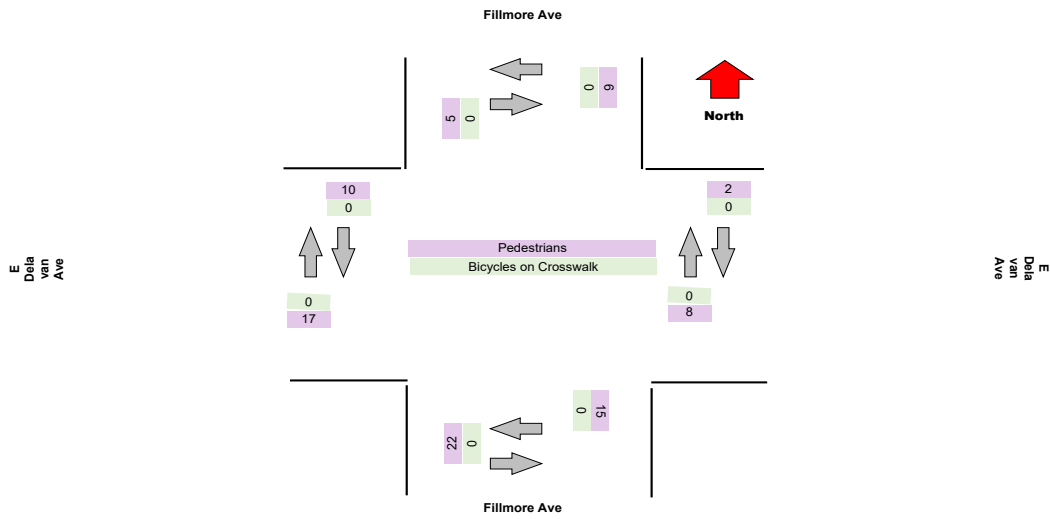
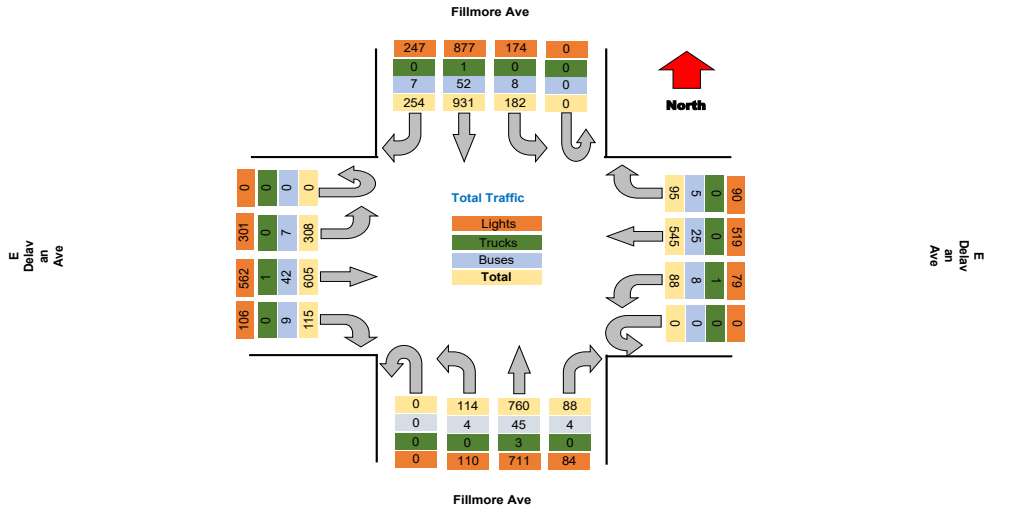

### Turning Movement Peak Hour Data (AM)

7:30:00 AM

Leg Direction	Fillmore Ave							E Delavan Ave							Fillmore Ave							E Delavan Ave							Total
	Southbound			Westbound				Northbound			Eastbound				Northbound			Eastbound											
Start Time	Right	Thru	Left	U-Turn	App Total	Peds CW	Peds CCW	Right	Thru	Left	U-Turn	App Total	Peds CW	Peds CCW	Right	Thru	Left	U-Turn	App Total	Peds CW	Peds CCW	Right	Thru	Left	U-Turn	App Total	Peds CW	Peds CCW	
7:30:00 AM	8	58	15	0	81	1	0	7	27	1	0	35	0	3	4	29	4	0	40	0	1	10	29	17	0	56	1	0	212
7:45:00 AM	20	95	19	0	134	2	1	3	42	2	0	48	0	2	11	67	3	0	83	2	1	5	41	19	0	65	1	2	330
8:00:00 AM	19	79	15	0	113	1	1	8	33	11	0	53	0	1	8	52	4	0	65	7	2	5	37	13	0	55	8	0	286
8:15:00 AM	21	63	16	0	100	0	0	5	39	10	0	54	0	0	4	36	4	0	44	0	2	3	36	19	0	58	0	0	256
<b>Grand Total</b>	<b>68</b>	<b>295</b>	<b>65</b>	<b>0</b>	<b>428</b>	<b>4</b>	<b>2</b>	<b>23</b>	<b>141</b>	<b>24</b>	<b>0</b>	<b>190</b>	<b>0</b>	<b>6</b>	<b>27</b>	<b>194</b>	<b>15</b>	<b>0</b>	<b>232</b>	<b>3</b>	<b>6</b>	<b>23</b>	<b>143</b>	<b>68</b>	<b>0</b>	<b>234</b>	<b>16</b>	<b>2</b>	<b>1084</b>
% Approach	15.9%	68.9%	15.2%	0.0%	0.0%	0.0%	0.0%	12.1%	74.2%	12.6%	0.0%	0.0%	0.0%	0.0%	11.6%	79.3%	6.5%	0.0%	0.0%	0.0%	0.0%	9.8%	61.1%	28.1%	0.0%	0.0%	0.0%	0.0%	
% Total	6.3%	27.2%	6.0%	0.0%	38.5%	0.0%	0.0%	2.1%	13.0%	2.2%	0.0%	17.5%	0.0%	0.0%	2.5%	17.0%	1.4%	0.0%	21.4%	0.0%	0.0%	2.1%	13.2%	6.3%	0.0%	21.6%	0.0%	0.0%	
PHF	0.810	0.778	0.855	0.000	0.799	0.000	0.000	0.719	0.839	0.545	0.000	0.880	0.000	0.000	0.614	0.687	0.938	0.000	0.699	0.000	0.000	0.575	0.872	0.895	0.000	0.900	0.000	0.000	
Lights	65	277	63	0	405	0	0	21	133	22	0	176	0	0	24	170	14	0	208	0	0	20	136	66	0	222	0	0	
% Lights	85.6%	93.9%	96.9%	0.0%	94.6%	0.0%	0.0%	81.3%	94.3%	91.7%	0.0%	92.6%	0.0%	0.0%	88.9%	92.4%	93.3%	0.0%	89.7%	0.0%	0.0%	87.0%	95.1%	97.1%	0.0%	94.9%	0.0%	0.0%	
Trucks	0	0	0	0	0	0	0	0	0	0	0	0	0	0	0	0	0	0	0	0	0	0	0	0	0	0	0	0	
% Trucks	0.0%	0.0%	0.0%	0.0%	0.0%	0.0%	0.0%	0.0%	0.0%	0.0%	0.0%	0.0%	0.0%	0.0%	0.0%	0.0%	0.0%	0.0%	0.0%	0.0%	0.0%	0.0%	0.0%	0.0%	0.0%	0.0%	0.0%	0.0%	
Buses	3	17	2	0	22	0	0	2	8	2	0	12	0	0	3	14	1	0	18	0	0	3	7	2	0	12	0	0	
% Buses	4.4%	5.8%	3.1%	0.0%	0.0%	0.0%	0.0%	8.7%	5.7%	8.3%	0.0%	0.0%	0.0%	0.0%	11.1%	7.8%	6.7%	0.0%	0.0%	0.0%	0.0%	13.0%	4.9%	2.9%	0.0%	0.0%	0.0%	0.0%	
Pedestrians	0	0	0	0	0	4	2	0	0	0	0	0	6	0	0	0	0	0	9	6	0	0	0	0	0	0	10	2	
% Pedestrians	0.0%	0.0%	0.0%	0.0%	0.0%	100.0%	100.0%	0.0%	0.0%	0.0%	0.0%	0.0%	100.0%	0.0%	0.0%	0.0%	0.0%	0.0%	0.0%	0.0%	100.0%	100.0%	0.0%	0.0%	0.0%	0.0%	100.0%	100.0%	
Bicycles on Crosswalk	0	0	0	0	0	0	0	0	0	0	0	0	0	0	0	0	0	0	0	0	0	0	0	0	0	0	0	0	
% Bicycles on Crosswalk	0.0%	0.0%	0.0%	0.0%	0.0%	0.0%	0.0%	0.0%	0.0%	0.0%	0.0%	0.0%	0.0%	0.0%	0.0%	0.0%	0.0%	0.0%	0.0%	0.0%	0.0%	0.0%	0.0%	0.0%	0.0%	0.0%	0.0%	0.0%	

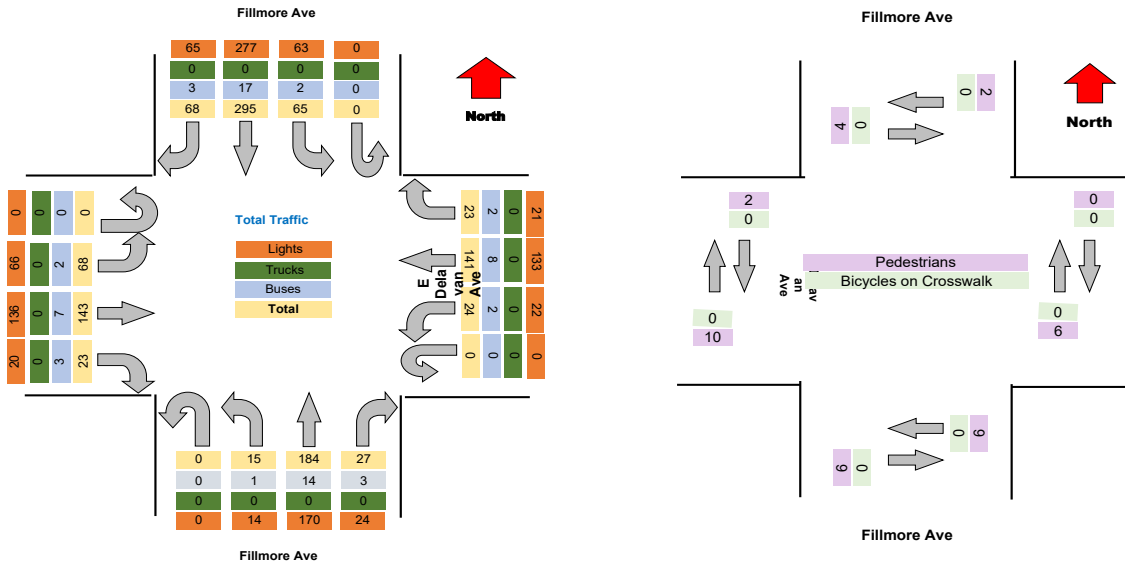

Project : VBH Malta NY  
Site : Site 4  
Location : 42.948550, -73.790036

TSTData.com

Survey Date : 2021-04-28, Wednesday

**Turning Movement Peak Hour Data (PM)**

4:45:00 PM

Leg Direction	Fillmore Ave				E Delavan Ave				Fillmore Ave				E Delavan Ave				Total				
	Southbound				Westbound				Northbound				Eastbound								
Start Time	Right	Thru	Left	U-Turn	App Total	Peds CW	Peds CCW	Right	Thru	Left	U-Turn	App Total	Peds CW	Peds CCW	Right	Thru	Left	U-Turn	App Total	Peds CW	Peds CCW
4:45:00 PM	16	52	19	0	87	1	1	8	43	11	0	62	1	1	9	72	15	0	96	0	0
5:00:00 PM	18	59	8	0	85	0	0	8	40	6	0	54	0	0	2	64	6	0	72	0	0
5:15:00 PM	24	70	8	0	102	0	1	6	34	5	0	45	0	0	8	62	8	0	78	1	1
5:30:00 PM	8	52	14	0	75	0	0	8	43	5	0	56	0	0	6	54	11	0	71	1	1
<b>Grand Total</b>	<b>67</b>	<b>233</b>	<b>49</b>	<b>0</b>	<b>349</b>	<b>1</b>	<b>2</b>	<b>30</b>	<b>160</b>	<b>27</b>	<b>0</b>	<b>217</b>	<b>1</b>	<b>2</b>	<b>25</b>	<b>252</b>	<b>40</b>	<b>0</b>	<b>317</b>	<b>2</b>	<b>2</b>
% Approach	19.2%	66.8%	14.0%	0.0%	0.0%	0.0%	0.0%	13.8%	73.7%	12.4%	0.0%	0.0%	0.0%	0.0%	7.9%	79.5%	12.6%	0.0%	0.0%	0.0%	0.0%
% Total	5.5%	19.2%	4.0%	0.0%	28.8%	0.0%	0.0%	2.5%	13.2%	2.2%	0.0%	17.9%	0.0%	0.0%	2.1%	20.8%	3.3%	0.0%	26.2%	0.0%	0.0%
PHF	0.698	0.832	0.645	0.000	0.855	0.000	0.000	0.938	0.930	0.614	0.000	0.875	0.000	0.000	0.694	0.875	0.667	0.000	0.826	0.000	0.000
Lights	66	226	47	0	339	0	0	29	156	26	0	211	0	0	24	240	39	0	303	0	0
% Lights	88.5%	97.0%	95.9%	0.0%	97.1%	0.0%	0.0%	96.7%	97.5%	96.3%	0.0%	97.2%	0.0%	0.0%	96.0%	95.2%	97.5%	0.0%	95.6%	0.0%	0.0%
Trucks	0	0	0	0	0	0	0	0	0	0	0	0	0	0	0	1	0	0	1	0	0
% Trucks	0.0%	0.0%	0.0%	0.0%	0.0%	0.0%	0.0%	0.0%	0.0%	0.0%	0.0%	0.0%	0.0%	0.0%	0.0%	0.4%	0.0%	0.0%	0.3%	0.0%	0.0%
Buses	1	7	2	0	10	0	0	1	4	1	0	6	0	0	1	10	1	0	12	0	0
% Buses	1.5%	3.0%	4.1%	0.0%	0.0%	0.0%	0.0%	3.3%	2.5%	3.7%	0.0%	0.0%	0.0%	0.0%	4.0%	4.0%	2.5%	0.0%	0.0%	0.0%	0.0%
Pedestrians	0	0	0	0	0	1	2	0	0	0	0	1	1	0	0	0	0	0	2	2	0
% Pedestrians	0.0%	0.0%	0.0%	0.0%	0.0%	100.0%	100.0%	0.0%	0.0%	0.0%	0.0%	0.0%	100.0%	100.0%	0.0%	0.0%	0.0%	0.0%	0.6%	100.0%	100.0%
Bicycles on Crosswalk	0	0	0	0	0	0	0	0	0	0	0	0	0	0	0	0	0	0	0	0	0
% Bicycles on Crosswalk	0.0%	0.0%	0.0%	0.0%	0.0%	0.0%	0.0%	0.0%	0.0%	0.0%	0.0%	0.0%	0.0%	0.0%	0.0%	0.0%	0.0%	0.0%	0.0%	0.0%	0.0%

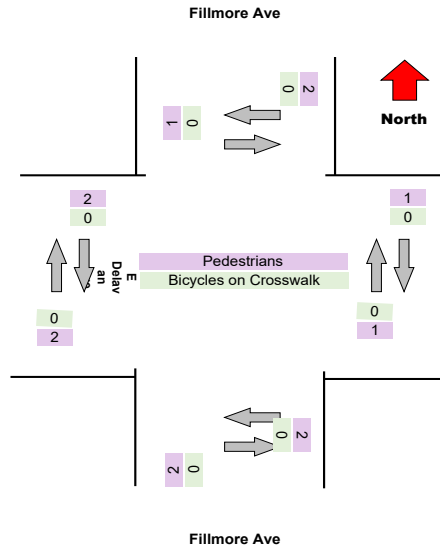
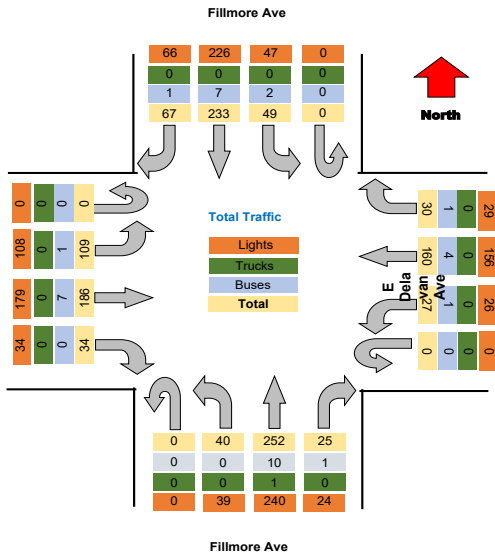



Project : VBH Malta NY  
 Site : Site 4  
 Location : 42.948550, -73.790036  
 Survey Date : 2021-04-28, Wednesday

### Turning Movement Data Plot

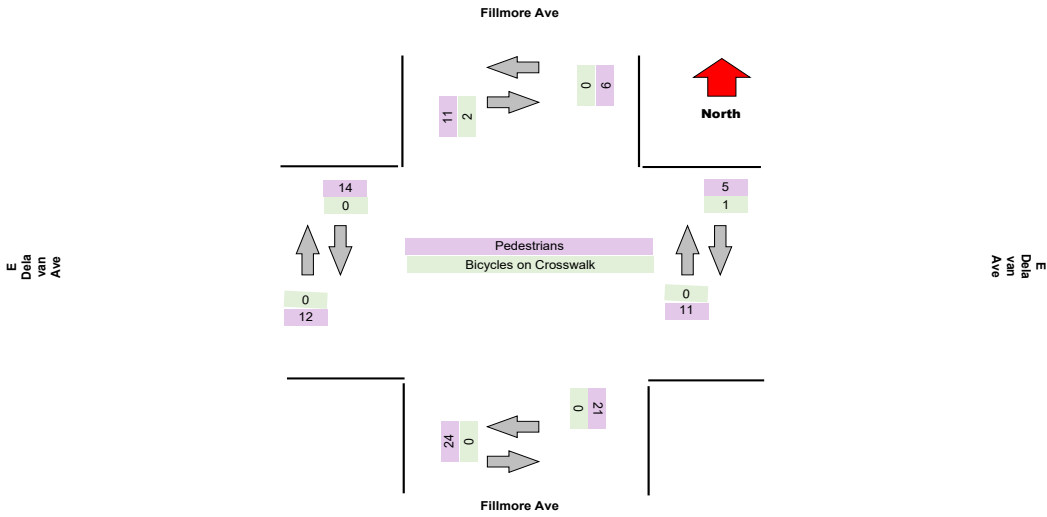
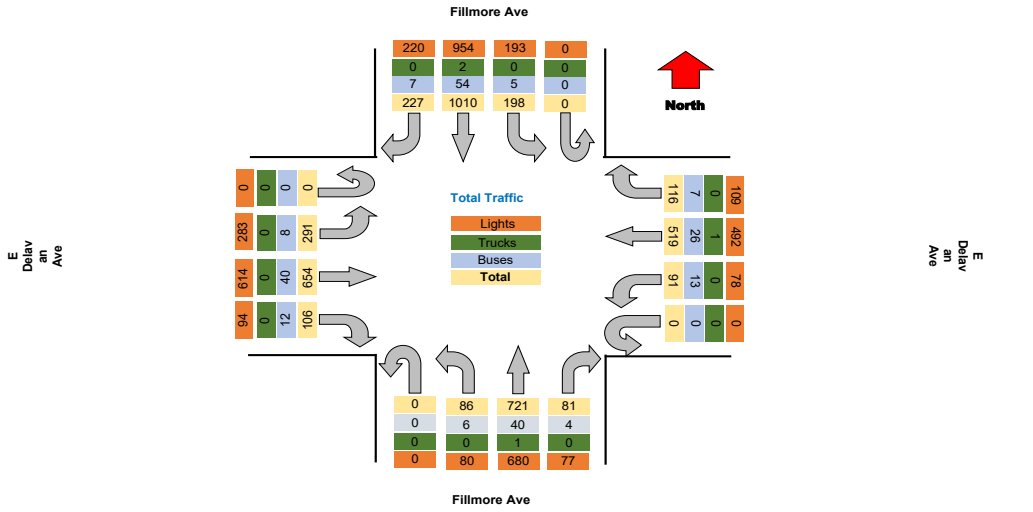



Project : VBH Malta NY  
Site : Site 4  
Location : 42.948550, -73.790036

TSTData.com

Survey Date : 2021-04-28, Wednesday

### Turning Movement Peak Hour Data (AM)

7:30:00 AM

Leg Direction	Fillmore Ave						E Delavan Ave						Fillmore Ave						E Delavan Ave						Total				
	Southbound			Northbound			Westbound			Eastbound			Northbound			Eastbound													
Start Time	Right	Thru	Left	U-Turn	App Total	Peds CW	Peds CCW	Right	Thru	Left	U-Turn	App Total	Peds CW	Peds CCW	Right	Thru	Left	U-Turn	App Total	Peds CW	Peds CCW	Right	Thru	Left	U-Turn	App Total	Peds CW	Peds CCW	
7:30:00 AM	6	73	13	0	92	2	1	4	32	5	0	42	0	0	2	30	3	0	35	1	2	5	33	23	0	61	1	1	230
7:45:00 AM	22	82	18	0	122	1	0	7	32	3	0	42	0	0	6	42	4	0	52	0	5	1	26	11	0	38	1	4	254
8:00:00 AM	19	74	17	0	110	0	0	5	37	6	0	50	1	1	9	39	4	0	54	0	0	6	54	24	0	84	1	0	298
8:15:00 AM	14	70	11	0	95	1	0	11	30	9	0	53	1	7	5	52	5	0	70	7	4	5	34	16	0	55	2	1	273
<b>Grand Total</b>	<b>61</b>	<b>299</b>	<b>59</b>	<b>0</b>	<b>419</b>	<b>4</b>	<b>1</b>	<b>27</b>	<b>131</b>	<b>25</b>	<b>0</b>	<b>187</b>	<b>2</b>	<b>8</b>	<b>22</b>	<b>183</b>	<b>16</b>	<b>0</b>	<b>211</b>	<b>3</b>	<b>11</b>	<b>17</b>	<b>147</b>	<b>74</b>	<b>0</b>	<b>238</b>	<b>3</b>	<b>6</b>	<b>1055</b>
% Approach	14.6%	71.4%	14.1%	0.0%	0.0%	0.0%	0.0%	14.4%	70.1%	13.4%	0.0%	0.0%	0.0%	0.0%	10.4%	77.3%	7.6%	0.0%	0.0%	0.0%	0.0%	7.1%	61.8%	31.1%	0.0%	0.0%	0.0%	0.0%	0.0%
% Total	5.8%	28.3%	5.6%	0.0%	38.7%	0.0%	0.0%	2.6%	12.4%	2.4%	0.0%	17.7%	0.0%	0.0%	2.1%	15.5%	1.5%	0.0%	20.0%	0.0%	0.0%	1.6%	13.9%	7.0%	0.0%	22.6%	0.0%	0.0%	0.0%
PHF	0.693	0.912	0.619	0.000	0.859	0.000	0.000	0.614	0.885	0.694	0.000	0.882	0.000	0.000	0.611	0.784	0.800	0.000	0.754	0.000	0.000	0.708	0.681	0.771	0.000	0.708	0.000	0.000	0.885
Lights	58	279	59	0	396	0	0	26	123	23	0	172	0	0	20	150	13	0	183	0	0	14	143	69	0	226	0	0	977
% Lights	85.1%	93.3%	100.0%	0.0%	94.5%	0.0%	0.0%	86.3%	93.9%	92.0%	0.0%	92.0%	0.0%	0.0%	80.9%	92.0%	81.3%	0.0%	86.7%	0.0%	0.0%	82.4%	97.3%	93.2%	0.0%	95.0%	0.0%	0.0%	92.6%
Trucks	0	0	0	0	0	0	0	0	0	0	0	0	0	0	0	0	0	0	0	0	0	0	0	0	0	0	0	0	0
% Trucks	0.0%	0.0%	0.0%	0.0%	0.0%	0.0%	0.0%	0.0%	0.0%	0.0%	0.0%	0.0%	0.0%	0.0%	0.0%	0.0%	0.0%	0.0%	0.0%	0.0%	0.0%	0.0%	0.0%	0.0%	0.0%	0.0%	0.0%	0.0%	0.0%
Buses	3	20	0	0	23	0	0	1	8	2	0	11	0	0	2	13	3	0	18	0	0	3	4	5	0	12	0	0	64
% Buses	4.9%	6.7%	0.0%	0.0%	0.0%	0.0%	0.0%	3.7%	6.1%	8.0%	0.0%	0.0%	0.0%	0.0%	9.1%	8.0%	18.8%	0.0%	0.0%	0.0%	0.0%	17.6%	2.7%	6.8%	0.0%	0.0%	0.0%	0.0%	6.1%
Pedestrians	0	0	0	0	0	4	4	0	0	0	0	0	2	6	0	0	0	0	0	8	11	0	0	0	0	0	5	6	0
% Pedestrians	0.0%	0.0%	0.0%	0.0%	0.0%	100.0%	100.0%	0.0%	0.0%	0.0%	0.0%	0.0%	100.0%	100.0%	0.0%	0.0%	0.0%	0.0%	0.0%	0.0%	0.0%	0.0%	0.0%	0.0%	0.0%	0.0%	0.0%	0.0%	0.0%
Bicycles on Crosswalk	0	0	0	0	0	0	0	0	0	0	0	0	0	0	0	0	0	0	0	0	0	0	0	0	0	0	0	0	0
% Bicycles on Crosswalk	0.0%	0.0%	0.0%	0.0%	0.0%	0.0%	0.0%	0.0%	0.0%	0.0%	0.0%	0.0%	0.0%	0.0%	0.0%	0.0%	0.0%	0.0%	0.0%	0.0%	0.0%	0.0%	0.0%	0.0%	0.0%	0.0%	0.0%	0.0%	0.0%

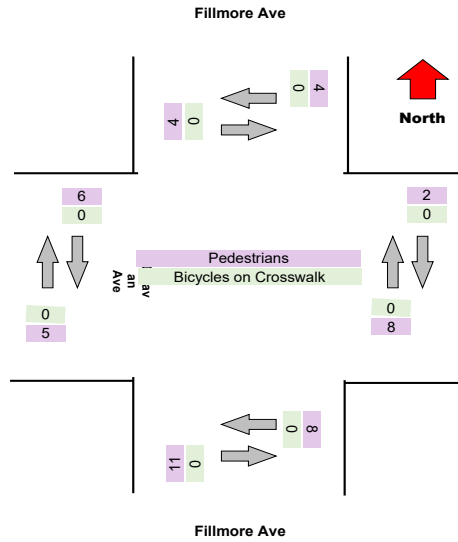
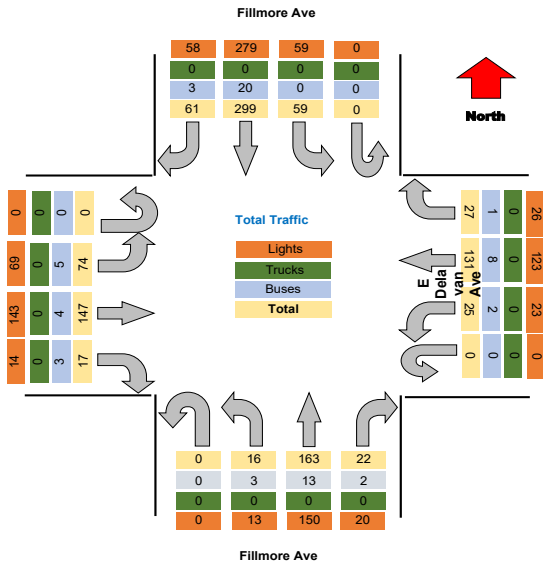

**Turning Movement Peak Hour Data (PM)**

4:45:00 PM

Leg Direction	Fillmore Ave										E Delavan Ave										Fillmore Ave										E Delavan Ave										Total
	Southbound					Westbound					Northbound					Eastbound																									
	Right	Thru	Left	U-Turn	App Total	Right	Thru	Left	U-Turn	App Total	Right	Thru	Left	U-Turn	App Total	Right	Thru	Left	U-Turn	App Total																					
4:45:00 PM	20	71	13	0	104	12	43	11	0	66	13	80	5	0	98	12	53	24	0	89																					
5:00:00 PM	15	72	18	0	105	10	30	6	0	46	2	70	6	0	78	6	42	25	0	73																					
5:15:00 PM	8	78	12	0	98	7	43	6	0	56	9	63	12	0	84	13	42	18	0	73																					
5:30:00 PM	20	59	9	0	88	8	34	6	0	48	4	58	9	0	72	11	48	17	0	76																					
<b>Grand Total</b>	<b>63</b>	<b>289</b>	<b>52</b>	<b>0</b>	<b>395</b>	<b>37</b>	<b>150</b>	<b>29</b>	<b>0</b>	<b>216</b>	<b>28</b>	<b>272</b>	<b>32</b>	<b>0</b>	<b>332</b>	<b>42</b>	<b>185</b>	<b>84</b>	<b>0</b>	<b>311</b>																					
% Approach	15.9%	70.9%	13.2%	0.0%	0.0%	17.1%	69.4%	13.4%	0.0%	0.0%	8.4%	81.6%	9.6%	0.0%	0.0%	13.5%	59.5%	27.0%	0.0%	0.0%																					
% Total	5.0%	22.3%	4.1%	0.0%	31.5%	3.0%	12.0%	2.3%	0.0%	17.2%	2.2%	21.7%	2.6%	0.0%	26.5%	3.3%	14.8%	6.7%	0.0%	24.8%																					
PHF	0.788	0.897	0.722	0.000	0.940	0.771	0.872	0.659	0.000	0.818	0.538	0.850	0.667	0.000	0.847	0.808	0.873	0.840	0.000	0.874																					
Lights	61	271	51	0	383	35	145	27	0	207	27	264	30	0	321	40	180	84	0	304																					
% Lights	96.8%	96.8%	98.1%	0.0%	97.0%	94.6%	96.7%	93.1%	0.0%	95.8%	96.4%	97.1%	93.8%	0.0%	96.7%	95.2%	97.3%	100.0%	0.0%	97.7%																					
Trucks	0	1	0	0	1	0	0	0	0	0	0	1	0	0	1	0	0	0	0	0																					
% Trucks	0.0%	0.4%	0.0%	0.0%	0.3%	0.0%	0.0%	0.0%	0.0%	0.0%	0.0%	0.4%	0.0%	0.0%	0.3%	0.0%	0.0%	0.0%	0.0%	0.0%																					
Buses	2	8	1	0	11	2	5	2	0	9	1	7	2	0	10	2	5	0	0	7																					
% Buses	3.2%	2.9%	1.9%	0.0%	0.0%	5.4%	3.3%	6.9%	0.0%	0.0%	3.6%	2.6%	6.3%	0.0%	0.0%	4.8%	2.7%	0.0%	0.0%	0.0%																					
Pedestrians	0	0	0	0	0	0	0	0	0	0	0	0	0	0	0	0	0	0	0	0																					
% Pedestrians	0.0%	0.0%	0.0%	0.0%	0.0%	0.0%	0.0%	0.0%	0.0%	0.0%	0.0%	0.0%	0.0%	0.0%	0.0%	0.0%	0.0%	0.0%	0.0%	0.0%																					
Bicycles on Crosswalk	0	0	0	0	0	0	0	0	0	0	0	0	0	0	0	0	0	0	0	0																					
% Bicycles on Crosswalk	0.0%	0.0%	0.0%	0.0%	0.0%	0.0%	0.0%	0.0%	0.0%	0.0%	0.0%	0.0%	0.0%	0.0%	0.0%	0.0%	0.0%	0.0%	0.0%	0.0%																					

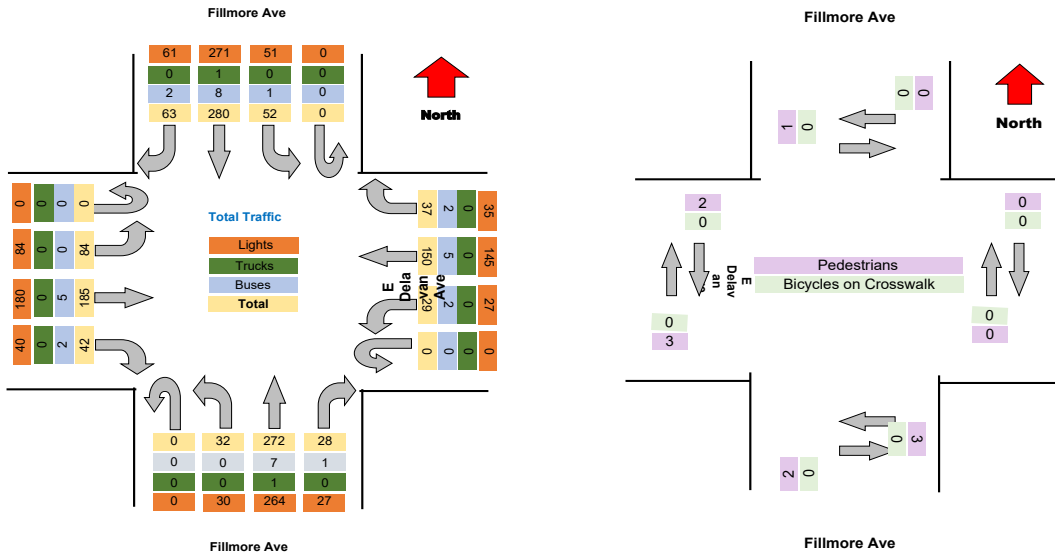



Project : VBH Malta NY  
 Site : Site 4  
 Location : 42.948550, -73.790036  
 Survey Date : 2021-04-28, Wednesday

### Turning Movement Data Plot

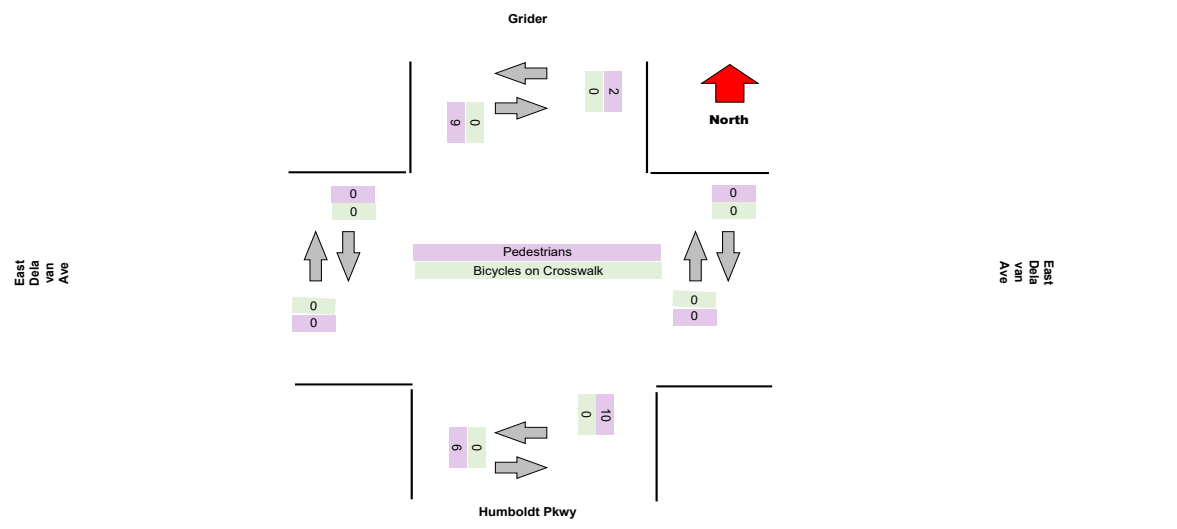
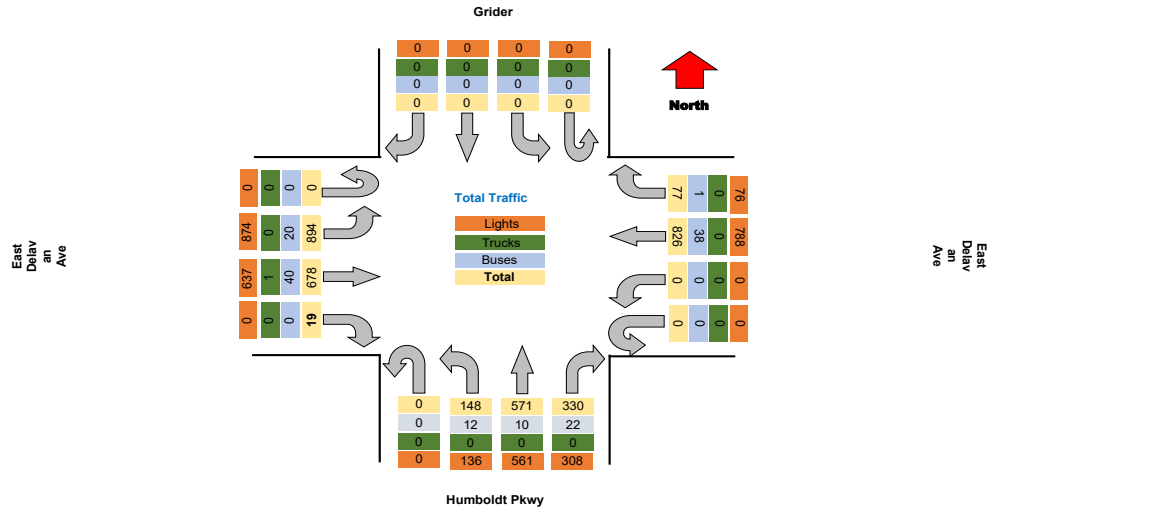

**Turning Movement Peak Hour Data (AM)**

7:30:00 AM

Leg Direction	Grider				East Delavan Ave				Humboldt Pkwy				East Delavan Ave				Total												
	Southbound		Northbound		Westbound		Eastbound		Northbound		Southbound		Eastbound																
Start Time	Right	Thru	Left	U-Turn	App Total	Peds CW	Peds CCW	Right	Thru	Left	U-Turn	App Total	Peds CW	Peds CCW	Right	Thru	Left	U-Turn	App Total	Peds CW	Peds CCW								
7:30:00 AM	0	0	0	0	0	0	0	4	44	0	0	48	0	0	19	30	8	0	57	0	1	0	31	73	0	104	0	0	209
7:45:00 AM	0	0	0	0	0	0	0	7	50	0	0	57	0	0	33	32	4	0	69	0	2	0	47	62	0	109	0	0	235
8:00:00 AM	0	0	0	0	0	0	2	6	69	0	0	77	0	0	22	36	7	0	65	1	0	0	41	57	0	98	0	0	240
8:15:00 AM	0	0	0	0	0	0	0	4	55	0	0	59	0	0	14	37	15	0	66	0	1	0	50	71	0	121	0	0	246
<b>Grand Total</b>	0	0	0	0	0	0	2	21	218	0	0	241	0	0	85	135	34	0	257	1	4	0	159	263	0	432	3	0	930
% Approach	#DIV/0!	#DIV/0!	#DIV/0!	#DIV/0!	0.0%	0.0%	0.0%	14.2%	85.8%	0.0%	0.0%	0.0%	0.0%	0.0%	45.1%	41.7%	13.2%	0.0%	0.0%	0.0%	0.0%	0.0%	66.2%	33.8%	0.0%	0.0%	0.0%	0.0%	
% Total	0.0%	0.0%	0.0%	0.0%	0.0%	0.0%	0.0%	2.3%	23.4%	0.0%	0.0%	25.9%	0.0%	0.0%	9.5%	14.5%	3.7%	0.0%	27.6%	0.0%	0.0%	0.0%	18.2%	28.3%	0.0%	46.5%	0.0%	0.0%	
PHF	0.000	0.000	0.000	0.000	0.000	0.000	0.000	0.750	0.780	0.000	0.000	0.782	0.000	0.000	0.667	0.912	0.567	0.000	0.831	0.000	0.000	0.000	0.845	0.901	0.000	0.893	0.000	0.000	0.845
Lights	0	0	0	0	0	0	0	21	207	0	0	228	0	0	85	131	31	0	247	0	0	0	162	258	0	420	0	0	895
% Lights	0.0%	0.0%	0.0%	0.0%	0.0%	0.0%	0.0%	100.0%	95.0%	0.0%	0.0%	94.6%	0.0%	0.0%	86.6%	97.0%	91.2%	0.0%	96.1%	0.0%	0.0%	0.0%	95.9%	98.1%	0.0%	97.2%	0.0%	0.0%	96.2%
Trucks	0	0	0	0	0	0	0	0	0	0	0	0	0	0	0	0	0	0	0	0	0	0	1	0	0	1	0	0	1
% Trucks	0.0%	0.0%	0.0%	0.0%	0.0%	0.0%	0.0%	0.0%	0.0%	0.0%	0.0%	0.0%	0.0%	0.0%	0.0%	0.0%	0.0%	0.0%	0.0%	0.0%	0.0%	0.0%	0.6%	0.0%	0.0%	0.2%	0.0%	0.0%	0.1%
Buses	0	0	0	0	0	0	0	0	11	0	0	11	0	0	3	4	3	0	10	0	0	0	6	5	0	11	0	0	32
% Buses	0.0%	0.0%	0.0%	0.0%	0.0%	0.0%	0.0%	0.0%	5.0%	0.0%	0.0%	0.0%	0.0%	0.0%	3.4%	3.0%	8.8%	0.0%	0.0%	0.0%	0.0%	0.0%	3.8%	1.9%	0.0%	0.0%	0.0%	0.0%	3.4%
Pedestrians	0	0	0	0	0	0	2	0	0	0	0	0	0	0	0	0	0	0	1	4	0	0	0	0	0	0	0	0	0
% Pedestrians	0.0%	0.0%	0.0%	0.0%	0.0%	0.0%	100.0%	0.0%	0.0%	0.0%	0.0%	0.0%	0.0%	0.0%	0.0%	0.0%	0.0%	0.0%	0.0%	100.0%	100.0%	0.0%	0.0%	0.0%	0.0%	0.0%	0.0%	0.0%	0.0%
Bicycles on Crosswalk	0	0	0	0	0	0	0	0	0	0	0	0	0	0	0	0	0	0	0	0	0	0	0	0	0	0	0	0	0
% Bicycles on Crosswalk	0.0%	0.0%	0.0%	0.0%	0.0%	0.0%	0.0%	0.0%	0.0%	0.0%	0.0%	0.0%	0.0%	0.0%	0.0%	0.0%	0.0%	0.0%	0.0%	0.0%	0.0%	0.0%	0.0%	0.0%	0.0%	0.0%	0.0%	0.0%	0.0%

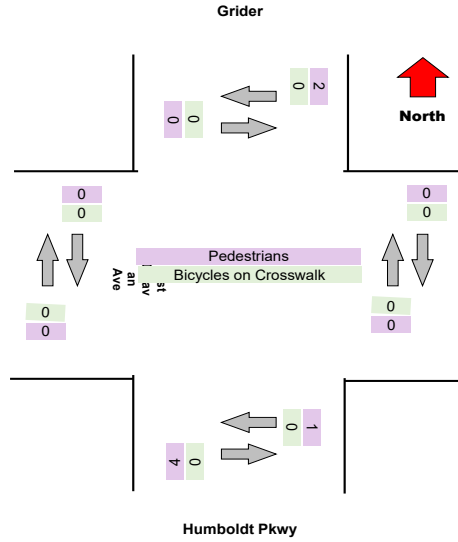
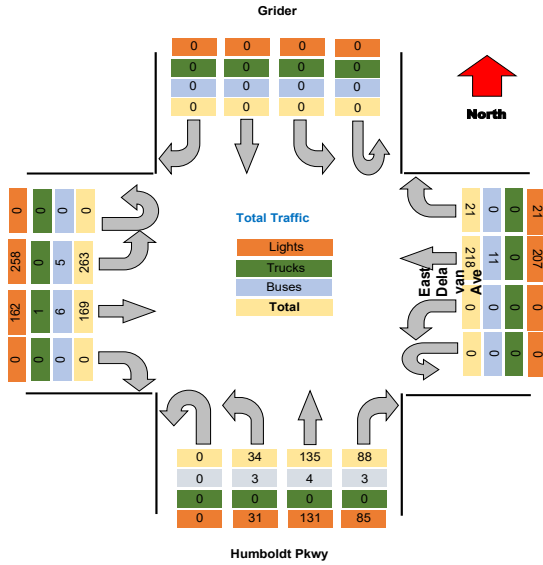

**Turning Movement Peak Hour Data (PM)**

4:30:00 PM

Leg Direction	Grider										East Delavan Ave										Total							
	Southbound					Westbound					Northbound					Eastbound												
	Right	Thru	Left	U-Turn	App Total	Peds CW	Peds CCW	Right	Thru	Left	U-Turn	App Total	Peds CW	Peds CCW	Right	Thru	Left	U-Turn	App Total	Peds CW		Peds CCW						
4:30:00 PM	0	0	0	0	0	4	71	0	0	75	0	0	0	0	0	31	39	6	0	76	1	1	0	136	0	0	0	287
4:45:00 PM	0	0	0	0	0	5	69	0	0	74	0	0	0	0	0	23	31	14	0	68	2	0	0	104	0	0	0	246
5:00:00 PM	0	0	0	0	0	3	53	0	0	56	0	0	0	0	0	25	47	7	0	79	0	0	0	88	0	0	0	233
5:15:00 PM	0	0	0	0	0	7	55	0	0	62	0	0	0	0	0	29	39	13	0	81	1	0	0	124	0	0	0	267
<b>Grand Total</b>	0	0	0	0	0	19	258	0	0	277	0	0	0	0	0	108	155	40	0	304	4	1	0	433	0	0	0	1033
<b>% Approach</b>	#DIV/0!	#DIV/0!	#DIV/0!	#DIV/0!	0.0%	14.2%	85.8%	0.0%	0.0%	0.0%	45.1%	41.7%	13.2%	0.0%	0.0%	0.0%	65.2%	33.8%	0.0%	0.0%	0.0%	0.0%	0.0%	0.0%	0.0%	0.0%	0.0%	0.0%
<b>% Total</b>	0.0%	0.0%	0.0%	0.0%	0.0%	1.8%	25.0%	0.0%	0.0%	26.8%	10.5%	15.1%	3.9%	0.0%	29.4%	0.0%	22.0%	21.8%	0.0%	43.8%	0.0%	0.0%	0.0%	0.0%	0.0%	0.0%	0.0%	0.0%
<b>PHF</b>	0.000	0.000	0.000	0.000	0.000	0.679	0.908	0.000	0.000	0.923	0.000	0.000	0.000	0.000	0.000	0.871	0.830	0.714	0.000	0.838	0.000	0.000	0.000	0.000	0.000	0.000	0.000	0.900
<b>Lights</b>	0	0	0	0	0	19	250	0	0	269	0	0	0	0	0	108	153	40	0	301	0	0	0	438	0	0	0	1008
<b>% Lights</b>	0.0%	0.0%	0.0%	0.0%	0.0%	100.0%	96.9%	0.0%	0.0%	97.1%	0.0%	0.0%	0.0%	0.0%	0.0%	100.0%	98.1%	100.0%	0.0%	99.0%	0.0%	0.0%	0.0%	96.9%	0.0%	0.0%	0.0%	97.6%
<b>Trucks</b>	0	0	0	0	0	0	0	0	0	0	0	0	0	0	0	0	0	0	0	0	0	0	0	0	0	0	0	0
<b>% Trucks</b>	0.0%	0.0%	0.0%	0.0%	0.0%	0.0%	0.0%	0.0%	0.0%	0.0%	0.0%	0.0%	0.0%	0.0%	0.0%	0.0%	0.0%	0.0%	0.0%	0.0%	0.0%	0.0%	0.0%	0.0%	0.0%	0.0%	0.0%	0.0%
<b>Buses</b>	0	0	0	0	0	0	8	0	0	8	0	0	0	0	0	0	3	0	0	3	0	0	0	14	0	0	0	25
<b>% Buses</b>	0.0%	0.0%	0.0%	0.0%	0.0%	0.0%	3.1%	0.0%	0.0%	0.0%	0.0%	1.9%	0.0%	0.0%	0.0%	0.0%	4.8%	1.3%	0.0%	0.0%	0.0%	0.0%	0.0%	0.0%	0.0%	0.0%	0.0%	2.4%
<b>Pedestrians</b>	0	0	0	0	5	0	0	0	0	0	0	0	0	0	4	0	0	0	0	0	0	0	0	0	0	0	0	0
<b>% Pedestrians</b>	0.0%	0.0%	0.0%	0.0%	100.0%	0.0%	0.0%	0.0%	0.0%	0.0%	0.0%	0.0%	0.0%	0.0%	0.0%	0.0%	0.0%	0.0%	0.0%	0.0%	0.0%	0.0%	0.0%	0.0%	0.0%	0.0%	0.0%	0.0%
<b>Bicycles on Crosswalk</b>	0	0	0	0	0	0	0	0	0	0	0	0	0	0	0	0	0	0	0	0	0	0	0	0	0	0	0	0
<b>% Bicycles on Crosswalk</b>	0.0%	0.0%	0.0%	0.0%	0.0%	0.0%	0.0%	0.0%	0.0%	0.0%	0.0%	0.0%	0.0%	0.0%	0.0%	0.0%	0.0%	0.0%	0.0%	0.0%	0.0%	0.0%	0.0%	0.0%	0.0%	0.0%	0.0%	0.0%

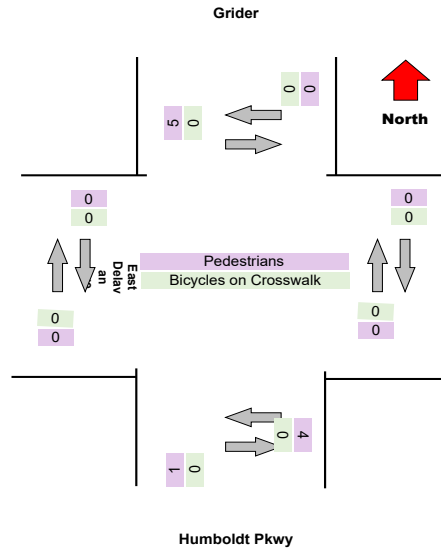
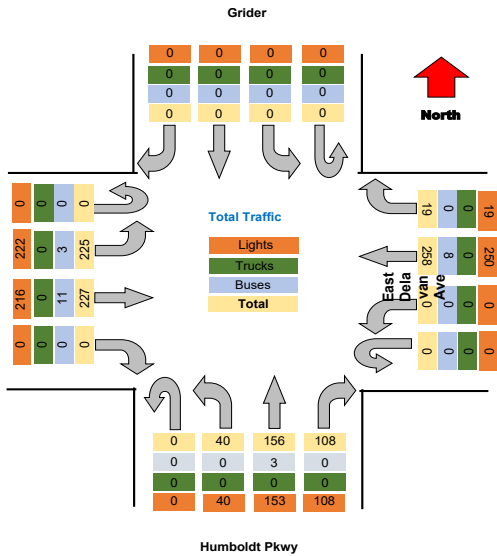

Project : VBH Malta NY  
Site : Site 4  
Location : 42.948550, -73.790036

TSTData.com

Survey Date : 2021-04-28, Wednesday

Project	Labella
Project Code	Labella
Site Name	27
Legs and Movements	All Processed Legs & Move
Bin Size	15 minutes
Survey Date	2021-10-27, Wednesday
Location	27
Latitude and Longitude	42.921924, -78.842814

	Start	End	PHF
Forced Peak AM	2021/10/27 07:30:00	2021/10/27 08:30:00	0.92
Forced Peak PM	2021/10/27 16:30:00	2021/10/27 17:30:00	0.92
AM Peak	2021/10/27 07:30:00	2021/10/27 08:30:00	0.92
PM Peak	2021/10/27 16:30:00	2021/10/27 17:30:00	0.92

### Turning Movement Data

Leg Direction	Grider								East Delavan Ave								Humboldt Pkwy								East Delavan Ave								Total
	Southbound				Westbound				Westbound				Northbound				Eastbound				Eastbound												
	Right	Thru	Left	U-Turn	App Total	Peds CV	Peds CCV		Right	Thru	Left	U-Turn	App Total	Peds CV	Peds CCV		Right	Thru	Left	U-Turn	App Total	Peds CV	Peds CCV		Right	Thru	Left	U-Turn	App Total	Peds CV	Peds CCV		
Start Time	0	0	0	0	0	0	0	0	7	14	0	0	21	0	0	0	11	26	5	0	42	0	0	0	0	17	53	0	70	0	0	0	
6:30:00 AM	0	0	0	0	0	0	0	0	2	27	0	0	29	0	0	0	12	35	3	0	50	0	0	0	0	23	50	0	73	0	0	0	
6:45:00 AM	0	0	0	0	0	0	0	0	9	41	0	0	50	0	0	0	23	61	8	0	92	0	0	0	0	40	103	0	143	0	0	0	
Hourly Total	0	0	0	0	0	0	0	0	1	21	0	0	22	0	0	0	6	28	7	0	41	1	1	1	0	19	52	0	71	0	0	0	
7:00:00 AM	0	0	0	0	0	0	0	0	3	36	0	0	39	1	1	1	17	38	14	0	69	0	3	0	0	33	55	0	88	0	0	0	
7:15:00 AM	0	0	0	0	0	0	0	0	4	38	0	0	43	0	0	0	18	41	10	0	69	3	2	0	0	23	73	0	96	1	0	0	
7:30:00 AM	0	0	0	0	0	0	0	0	5	54	0	0	59	1	0	0	19	34	11	0	65	1	2	0	0	46	67	0	113	0	0	0	
7:45:00 AM	0	0	0	0	0	0	0	0	13	149	0	0	163	2	1	0	60	139	42	0	244	5	8	0	0	121	247	0	368	1	0	0	
Hourly Total	0	0	0	0	0	0	0	0	6	53	0	0	59	0	0	0	27	36	13	0	76	2	4	0	0	45	49	0	94	0	1	0	
8:00:00 AM	0	0	0	0	0	0	0	0	1	47	0	0	48	0	0	0	6	35	10	0	51	1	0	0	0	35	65	0	100	2	1	0	
8:15:00 AM	0	0	0	0	0	0	0	0	7	100	0	0	107	0	0	0	33	71	23	0	127	3	4	0	0	80	114	0	194	2	2	0	
Hourly Total	0	0	0	0	0	0	0	0	11	76	0	0	87	0	0	0	26	43	21	0	90	1	0	0	0	67	54	0	121	0	0	0	
4:00:00 PM	0	0	0	0	0	0	0	0	5	80	0	0	85	1	0	0	44	39	10	0	93	4	1	0	0	66	51	0	117	1	0	0	
4:15:00 PM	0	0	0	0	0	0	0	0	6	65	0	0	71	0	0	0	44	48	19	0	111	4	1	0	0	73	50	0	123	0	0	0	
4:30:00 PM	0	0	0	0	0	0	0	0	9	68	0	0	77	1	0	0	29	46	10	0	85	1	0	0	0	68	53	0	121	0	0	0	
4:45:00 PM	0	0	0	0	0	0	0	0	31	289	0	0	320	2	0	0	143	176	80	0	379	10	2	0	0	274	208	0	482	1	0	0	
Hourly Total	0	0	0	0	0	0	0	0	7	62	0	0	69	0	0	0	22	50	13	0	85	0	0	0	0	48	48	0	96	0	0	0	
5:00:00 PM	0	0	0	0	0	0	0	0	6	54	0	0	60	0	0	0	31	56	22	0	109	1	0	0	0	50	60	0	110	1	0	0	
5:15:00 PM	0	0	0	0	0	0	0	0	8	60	0	0	68	0	0	0	21	53	7	0	81	1	1	0	0	55	56	0	111	0	0	0	
5:30:00 PM	0	0	0	0	0	0	0	0	7	65	0	0	72	0	0	0	17	53	13	0	83	0	0	0	0	35	53	0	88	0	0	0	
5:45:00 PM	0	0	0	0	0	0	0	0	28	241	0	0	269	0	0	0	91	212	55	0	358	2	1	0	0	188	217	0	405	1	0	0	
Hourly Total	0	0	0	0	0	0	0	0	88	820	0	0	909	4	1	0	350	659	188	0	1200	20	15	0	0	703	889	0	1592	5	2	0	
Grand Total	0	0	0	0	0	0	0	0	8.7%	90.2%	0.0%	0.0%	0.0%	0.0%	0.0%	0.0%	29.2%	54.9%	15.7%	0.0%	0.0%	0.0%	0.0%	0.0%	0.0%	44.2%	55.8%	0.0%	0.0%	0.0%	0.0%	0.0%	
% Approach	0.0%	0.0%	0.0%	0.0%	0.0%	0.0%	0.0%	0.0%	2.4%	22.2%	0.0%	0.0%	24.6%	0.0%	0.0%	0.0%	9.5%	17.8%	5.1%	0.0%	32.4%	0.0%	0.0%	0.0%	0.0%	19.0%	24.0%	0.0%	43.0%	0.0%	0.0%	0.0%	
% Total	0	0	0	0	0	0	0	0	87	781	0	0	868	0	0	0	325	649	175	0	1149	0	0	0	0	664	871	0	1535	0	0	0	
Lights	0	0	0	0	0	0	0	0	58.9%	85.2%	0.0%	0.0%	85.5%	0.0%	0.0%	0.0%	92.9%	88.5%	93.1%	0.0%	95.8%	0.0%	0.0%	0.0%	0.0%	94.5%	98.0%	0.0%	96.4%	0.0%	0.0%	0.0%	
% Lights	0	0	0	0	0	0	0	0	0	0	0	0	0	0	0	0	0	0	0	0	0	0	0	0	0	0	0	0	0	0	0	0	
Trucks	0	0	0	0	0	0	0	0	0.0%	0.0%	0.0%	0.0%	0.0%	0.0%	0.0%	0.0%	0.0%	0.0%	0.0%	0.0%	0.0%	0.0%	0.0%	0.0%	0.0%	0.0%	0.0%	0.0%	0.0%	0.0%	0.0%	0.0%	
% Trucks	0	0	0	0	0	0	0	0	1	39	0	0	40	0	0	0	25	10	13	0	48	0	0	0	0	38	18	0	56	0	0	0	
Buses	0	0	0	0	0	0	0	0	0.0%	4.8%	0.0%	0.0%	0.0%	0.0%	0.0%	0.0%	7.1%	1.5%	6.9%	0.0%	0.0%	0.0%	0.0%	0.0%	0.0%	0.0%	2.0%	0.0%	0.0%	0.0%	0.0%	0.0%	
% Buses	0	0	0	0	0	0	0	0	0	0	0	0	0	4	1	0	0	0	0	0	0	20	14	0	0	0	0	0	0	5	2	0	
Pedestrians	0	0	0	0	0	0	0	0	0.0%	0.0%	0.0%	0.0%	0.0%	100.0%	100.0%	0.0%	0.0%	0.0%	0.0%	0.0%	0.0%	100.0%	93.3%	0.0%	0.0%	0.0%	0.0%	0.0%	0.0%	100.0%	100.0%	0.0%	
% Pedestrians	0	0	0	0	0	1	1	0	0	0	0	0	0	0	0	0	0	0	0	0	0	0	0	0	0	0	0	0	0	0	0		
Bicycles on Crosswalk	0	0	0	0	0	0	0	0	0.0%	0.0%	0.0%	0.0%	0.0%	0.0%	0.0%	0.0%	0.0%	0.0%	0.0%	0.0%	0.0%	0.0%	0.0%	0.0%	0.0%	0.0%	0.0%	0.0%	0.0%	0.0%	0.0%	0.0%	
% Bicycles on Crosswalk	0.0%	0.0%	0.0%	0.0%	0.0%	16.7%	50.0%	0.0%	0.0%	0.0%	0.0%	0.0%	0.0%	0.0%	0.0%	0.0%	0.0%	0.0%	0.0%	0.0%	0.0%	0.0%	0.0%	0.0%	0.0%	0.0%	0.0%	0.0%	0.0%	0.0%	0.0%	0.0%	0.0%

Project : VBH Malta NY  
 Site : Site 4  
 Location : 42.948550, -73.790036  
 Survey Date : 2021-04-28, Wednesday

### Turning Movement Data Plot

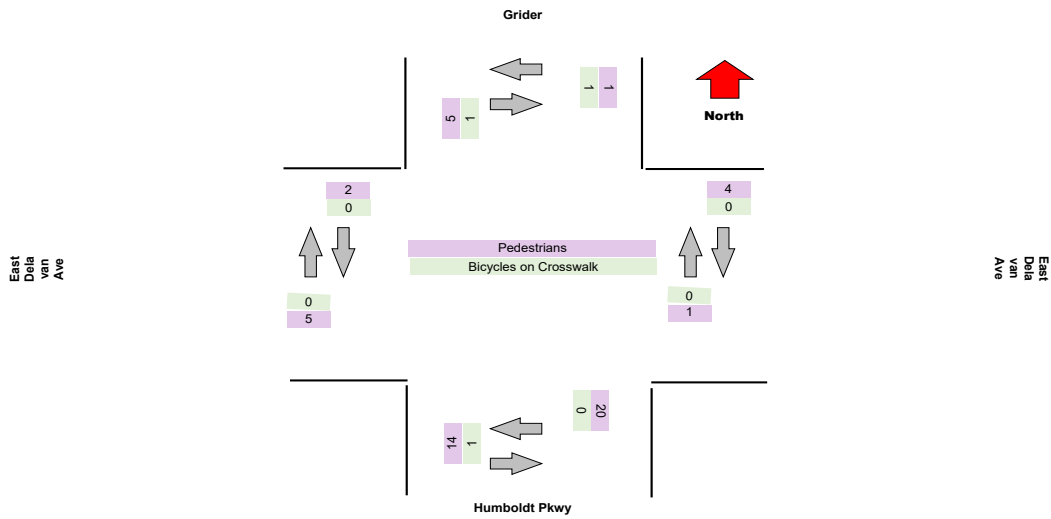
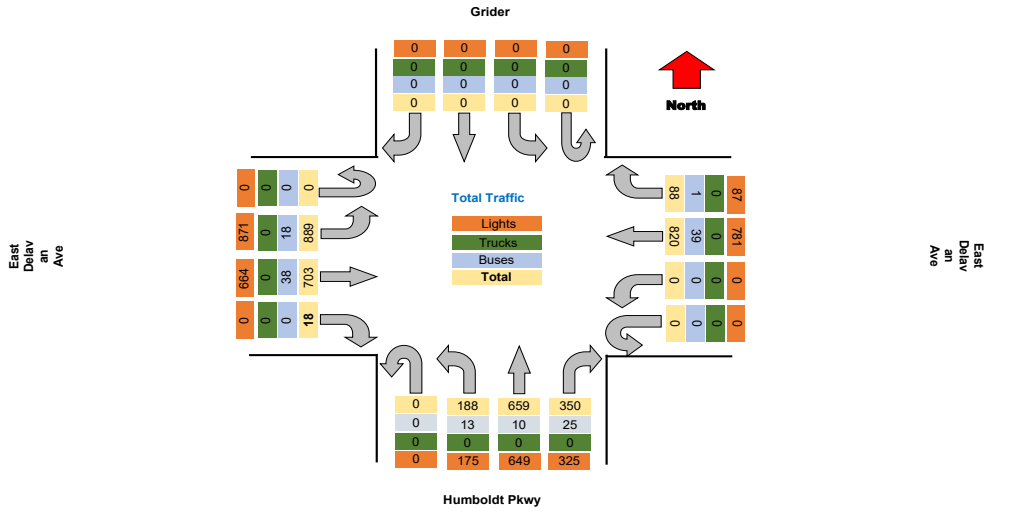



**Turning Movement Peak Hour Data (AM)**

7:30:00 AM

Leg Direction	Grider										East Delavan Ave										Humboldt Pkwy										East Delavan Ave										Total
	Southbound					Westbound					Northbound					Eastbound					Northbound					Eastbound															
	Right	Thru	Left	U-Turn	App Total	Right	Thru	Left	U-Turn	App Total	Right	Thru	Left	U-Turn	App Total	Right	Thru	Left	U-Turn	App Total	Right	Thru	Left	U-Turn	App Total	Right	Thru	Left	U-Turn	App Total											
7:30:00 AM	0	0	0	0	0	4	38	0	0	43	18	41	10	0	69	0	23	73	0	96	0	0	0	0	0	0	23	73	0	96											
7:45:00 AM	0	0	0	0	0	5	54	0	0	59	19	34	11	0	65	0	46	67	0	113	0	0	0	0	0	0	46	67	0	113											
8:00:00 AM	0	0	0	0	0	6	53	0	0	59	27	36	13	0	76	0	45	49	0	94	0	0	0	0	0	0	45	49	0	94											
8:15:00 AM	0	0	0	0	0	1	47	0	0	48	6	36	10	0	51	0	35	65	0	100	0	0	0	0	0	0	35	65	0	100											
<b>Grand Total</b>	0	0	0	0	0	16	192	0	0	209	70	146	44	0	251	0	149	254	0	403	0	0	0	0	0	0	149	254	0	403											
% Approach	#DIV/0!	#DIV/0!	#DIV/0!	#DIV/0!	0.0%	14.2%	85.8%	0.0%	0.0%	0.0%	45.1%	41.7%	13.2%	0.0%	0.0%	0.0%	66.2%	33.8%	0.0%	0.0%	0.0%	17.1%	29.1%	0.0%	46.2%	0.0%	0.0%	0.0%	0.0%	0.0%											
% Total	0.0%	0.0%	0.0%	0.0%	0.0%	1.8%	22.0%	0.0%	0.0%	23.9%	8.0%	16.7%	5.0%	0.0%	29.9%	0.0%	17.1%	29.1%	0.0%	46.2%	0.0%	0.0%	0.0%	0.0%	0.0%	0.0%	17.1%	29.1%	0.0%	46.2%											
PHF	0.000	0.000	0.000	0.000	0.000	0.667	0.889	0.000	0.000	0.886	0.648	0.890	0.846	0.000	0.859	0.000	0.000	0.000	0.000	0.000	0.000	0.810	0.870	0.000	0.892	0.000	0.000	0.000	0.000	0.921											
Lights	0	0	0	0	0	16	178	0	0	194	69	140	41	0	250	0	139	251	0	390	0	0	0	0	0	0	139	251	0	390											
% Lights	0.0%	0.0%	0.0%	0.0%	0.0%	100.0%	92.7%	0.0%	0.0%	92.8%	88.6%	95.9%	93.2%	0.0%	95.8%	0.0%	93.3%	98.8%	0.0%	96.8%	0.0%	0.0%	0.0%	0.0%	0.0%	0.0%	93.3%	98.8%	0.0%	96.8%											
Trucks	0	0	0	0	0	0	0	0	0	0	0	0	0	0	0	0	0	0	0	0	0	0	0	0	0	0	0	0	0	0											
% Trucks	0.0%	0.0%	0.0%	0.0%	0.0%	0.0%	0.0%	0.0%	0.0%	0.0%	0.0%	0.0%	0.0%	0.0%	0.0%	0.0%	0.0%	0.0%	0.0%	0.0%	0.0%	0.0%	0.0%	0.0%	0.0%	0.0%	0.0%	0.0%	0.0%	0.0%											
Buses	0	0	0	0	0	0	14	0	0	14	1	6	3	0	10	0	10	3	0	13	0	0	0	0	0	0	10	3	0	13											
% Buses	0.0%	0.0%	0.0%	0.0%	0.0%	0.0%	7.3%	0.0%	0.0%	0.0%	1.4%	4.1%	6.8%	0.0%	0.0%	0.0%	6.7%	1.2%	0.0%	0.0%	0.0%	0.0%	0.0%	0.0%	0.0%	0.0%	6.7%	1.2%	0.0%	0.0%											
Pedestrians	0	0	0	0	0	0	0	0	0	0	0	0	0	0	0	0	0	0	0	0	0	0	0	0	0	0	0	0	0	0											
% Pedestrians	0.0%	0.0%	0.0%	0.0%	0.0%	0.0%	0.0%	0.0%	0.0%	0.0%	0.0%	0.0%	0.0%	0.0%	0.0%	0.0%	0.0%	0.0%	0.0%	0.0%	0.0%	0.0%	0.0%	0.0%	0.0%	0.0%	0.0%	0.0%	0.0%	0.0%											
Bicycles on Crosswalk	0	0	0	0	0	0	0	0	0	0	0	0	0	0	0	0	0	0	0	0	0	0	0	0	0	0	0	0	0	0											
% Bicycles on Crosswalk	0.0%	0.0%	0.0%	0.0%	0.0%	0.0%	0.0%	0.0%	0.0%	0.0%	0.0%	0.0%	0.0%	0.0%	0.0%	0.0%	0.0%	0.0%	0.0%	0.0%	0.0%	0.0%	0.0%	0.0%	0.0%	0.0%	0.0%	0.0%	0.0%	0.0%											

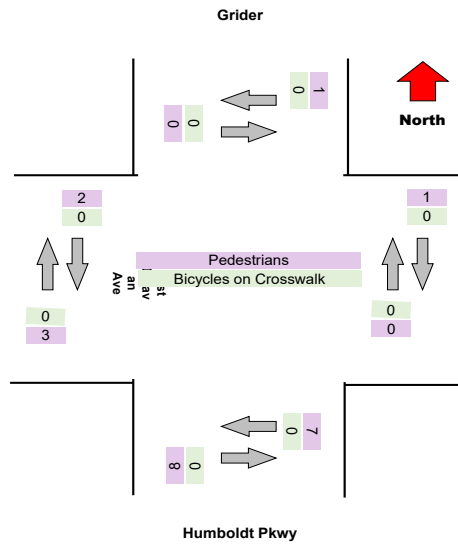
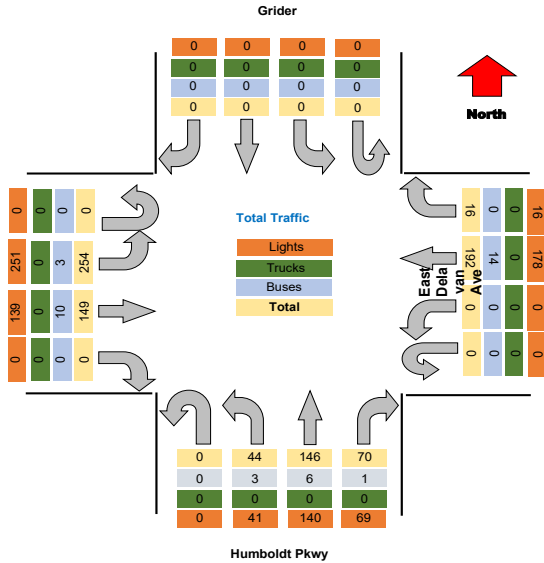

**Turning Movement Peak Hour Data (PM)**

4:30:00 PM

Leg Direction	Grider										East Delavan Ave										Total					
	Southbound					Westbound					Northbound					Eastbound										
	Right	Thru	Left	U-Turn	App Total	Right	Thru	Left	U-Turn	App Total	Right	Thru	Left	U-Turn	App Total	Right	Thru	Left	U-Turn	App Total						
4:30:00 PM	0	0	0	0	0	6	65	0	0	71	44	48	19	0	111	4	1	0	0	5	0	73	50	0	123	305
4:45:00 PM	0	0	0	0	0	9	68	0	0	77	29	46	10	0	85	1	0	0	0	1	0	68	53	0	121	283
5:00:00 PM	0	0	0	0	0	7	52	0	0	59	22	50	13	0	85	0	0	0	0	0	0	48	48	0	96	250
5:15:00 PM	0	0	0	0	0	6	54	0	0	60	31	56	22	0	109	1	0	0	0	1	0	50	50	0	100	279
<b>Grand Total</b>	0	0	0	0	0	28	249	0	0	277	125	200	64	0	389	6	1	0	0	7	0	229	210	0	439	1117
% Approach	#DIV/0!	#DIV/0!	#DIV/0!	#DIV/0!	0.0%	14.2%	85.8%	0.0%	0.0%	0.0%	45.1%	41.7%	13.2%	0.0%	0.0%	0.0%	0.0%	0.0%	0.0%	0.0%	0.0%	66.2%	33.8%	0.0%	0.0%	
% Total	0.0%	0.0%	0.0%	0.0%	0.0%	2.5%	22.3%	0.0%	0.0%	24.8%	11.3%	17.9%	5.7%	0.0%	34.9%	0.0%	0.0%	0.0%	0.0%	0.0%	0.0%	21.4%	18.9%	0.0%	40.3%	
PHF	0.000	0.000	0.000	0.000	0.000	0.778	0.915	0.000	0.000	0.899	0.716	0.893	0.727	0.000	0.878	0.000	0.000	0.000	0.000	0.000	0.000	0.818	0.879	0.000	0.915	0.916
Lights	0	0	0	0	0	28	240	0	0	268	125	196	64	0	385	0	0	0	0	0	0	229	210	0	439	1092
% Lights	0.0%	0.0%	0.0%	0.0%	0.0%	100.0%	96.4%	0.0%	0.0%	96.8%	99.2%	98.0%	100.0%	0.0%	98.7%	0.0%	0.0%	0.0%	0.0%	0.0%	0.0%	95.8%	99.5%	0.0%	97.6%	97.8%
Trucks	0	0	0	0	0	0	0	0	0	0	0	0	0	0	0	0	0	0	0	0	0	0	0	0	0	0
% Trucks	0.0%	0.0%	0.0%	0.0%	0.0%	0.0%	0.0%	0.0%	0.0%	0.0%	0.0%	0.0%	0.0%	0.0%	0.0%	0.0%	0.0%	0.0%	0.0%	0.0%	0.0%	0.0%	0.0%	0.0%	0.0%	0.0%
Buses	0	0	0	0	0	0	9	0	0	9	1	4	0	0	5	0	0	0	0	0	0	10	1	0	11	25
% Buses	0.0%	0.0%	0.0%	0.0%	0.0%	0.0%	3.6%	0.0%	0.0%	0.0%	0.8%	2.0%	0.0%	0.0%	0.0%	0.0%	0.0%	0.0%	0.0%	0.0%	0.0%	4.2%	0.5%	0.0%	0.0%	2.2%
Pedestrians	0	0	0	0	0	0	0	0	0	0	0	0	0	0	0	0	0	0	0	0	0	0	0	0	0	0
% Pedestrians	0.0%	0.0%	0.0%	0.0%	0.0%	0.0%	0.0%	0.0%	0.0%	0.0%	0.0%	0.0%	0.0%	0.0%	0.0%	0.0%	0.0%	0.0%	0.0%	0.0%	0.0%	0.0%	0.0%	0.0%	0.0%	0.0%
Bicycles on Crosswalk	0	0	0	0	0	0	0	0	0	0	0	0	0	0	0	0	0	0	0	0	0	0	0	0	0	0
% Bicycles on Crosswalk	0.0%	0.0%	0.0%	0.0%	0.0%	0.0%	0.0%	0.0%	0.0%	0.0%	0.0%	0.0%	0.0%	0.0%	0.0%	0.0%	0.0%	0.0%	0.0%	0.0%	0.0%	0.0%	0.0%	0.0%	0.0%	0.0%

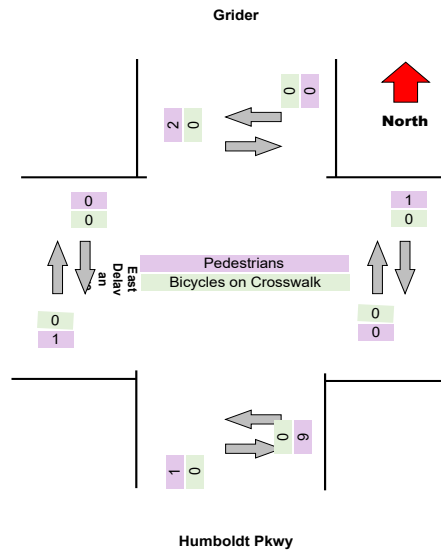
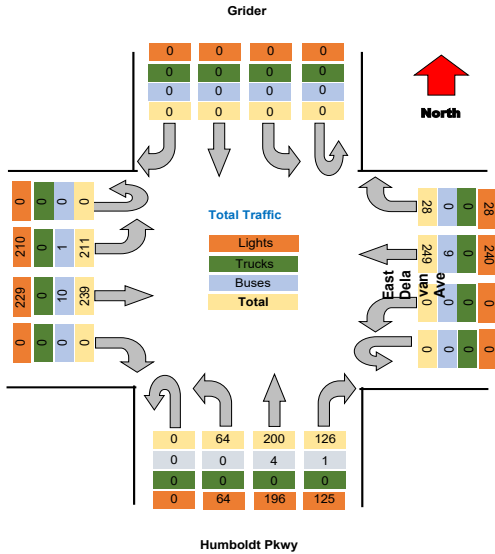



**Turning Movement Data Plot**

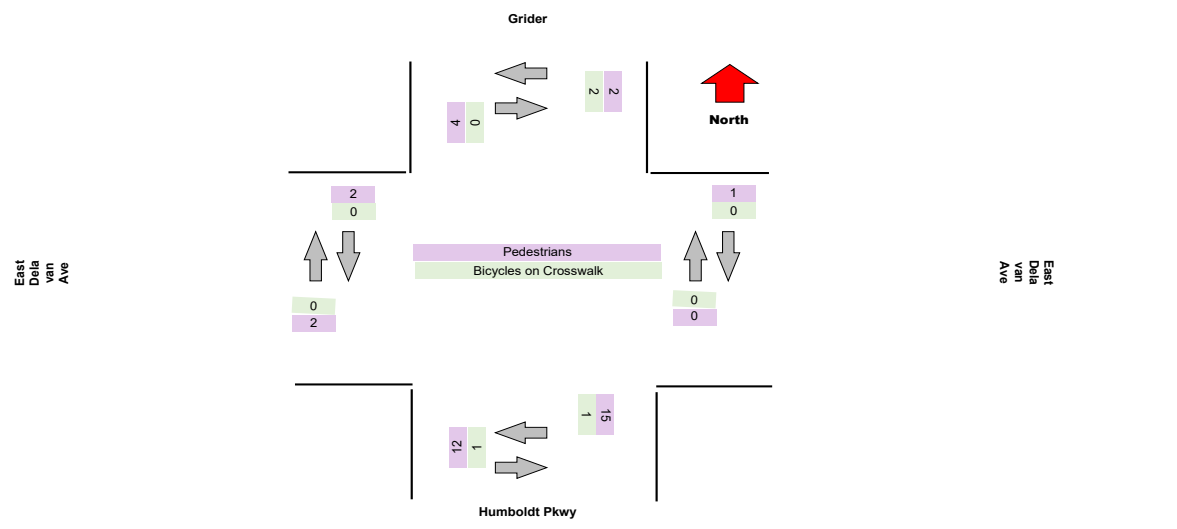
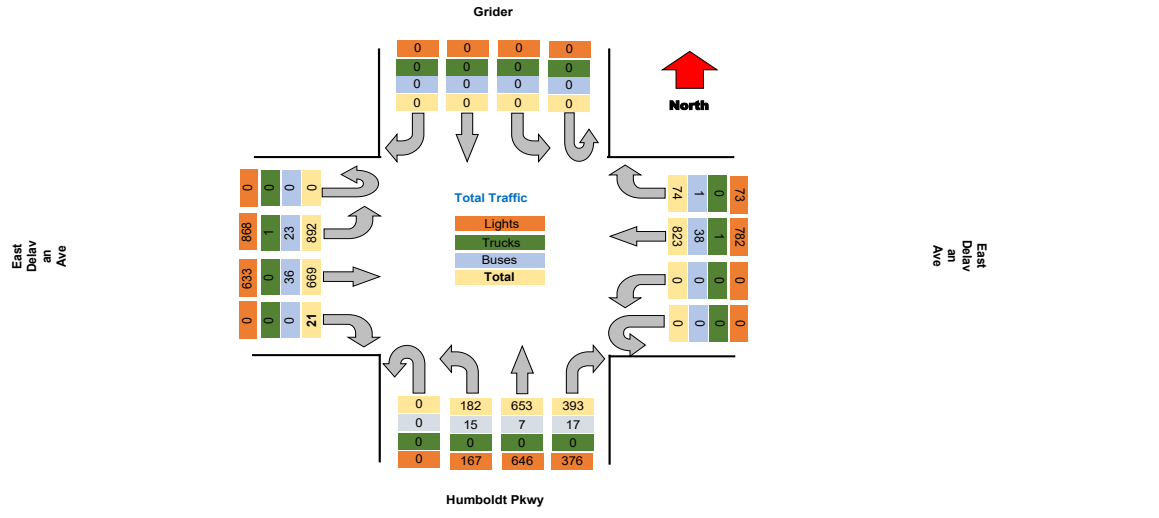

**Turning Movement Peak Hour Data (AM)**

7:30:00 AM

Leg Direction	Grider										East Delavan Ave										Humboldt Pkwy										East Delavan Ave										Total
	Southbound					Westbound					Northbound					Eastbound					Northbound					Eastbound															
	Right	Thru	Left	U-Turn	App Total	Right	Thru	Left	U-Turn	App Total	Right	Thru	Left	U-Turn	App Total	Right	Thru	Left	U-Turn	App Total	Right	Thru	Left	U-Turn	App Total	Right	Thru	Left	U-Turn	App Total											
7:30:00 AM	0	0	0	0	0	3	44	0	0	47	21	29	9	0	60	0	32	69	0	101	0	0	0	0	0	0	0	0	0	0											
7:45:00 AM	0	0	0	0	0	3	68	0	0	71	30	44	8	0	82	0	46	66	0	112	0	0	0	0	0	0	0	0	0	0											
8:00:00 AM	0	0	0	0	0	4	60	0	0	64	33	33	16	0	82	0	47	47	0	94	0	0	0	0	0	0	0	0	0	0											
8:15:00 AM	0	0	0	0	0	2	47	0	0	49	14	36	12	0	61	0	36	64	0	100	0	0	0	0	0	0	0	0	0	0											
<b>Grand Total</b>	0	0	0	0	0	12	219	0	0	231	88	141	45	0	274	0	151	241	0	392	0	0	0	0	0	0	0	0	0	0											
% Approach	#DIV/0!	#DIV/0!	#DIV/0!	#DIV/0!	0.0%	14.2%	85.8%	0.0%	0.0%	0.0%	45.1%	41.7%	13.2%	0.0%	0.0%	0.0%	66.2%	33.8%	0.0%	0.0%	0.0%	17.4%	26.6%	0.0%	44.0%	0.0%	0.0%	0.0%	0.0%	0.0%											
% Total	0.0%	0.0%	0.0%	0.0%	0.0%	1.3%	23.7%	0.0%	0.0%	25.3%	10.6%	15.2%	4.9%	0.0%	30.8%	0.0%	17.4%	26.6%	0.0%	44.0%	0.0%	0.0%	0.0%	0.0%	0.0%	0.0%	0.0%	0.0%	0.0%	0.0%											
PHF	0.000	0.000	0.000	0.000	0.000	0.750	0.805	0.000	0.000	0.824	0.742	0.801	0.703	0.000	0.869	0.000	0.856	0.891	0.000	0.908	0.000	0.000	0.000	0.000	0.000	0.000	0.000	0.000	0.000	0.000											
Lights	0	0	0	0	0	12	203	0	0	215	95	138	42	0	275	0	152	241	0	393	0	0	0	0	0	0	0	0	0	0											
% Lights	0.0%	0.0%	0.0%	0.0%	0.0%	100.0%	92.7%	0.0%	0.0%	91.9%	96.9%	97.0%	93.3%	0.0%	96.5%	0.0%	94.4%	98.0%	0.0%	96.6%	0.0%	0.0%	0.0%	0.0%	0.0%	0.0%	0.0%	0.0%	0.0%	0.0%											
Trucks	0	0	0	0	0	0	1	0	0	1	0	0	0	0	0	0	0	1	0	1	0	0	0	0	0	0	0	0	0	0											
% Trucks	0.0%	0.0%	0.0%	0.0%	0.0%	0.0%	0.5%	0.0%	0.0%	0.4%	0.0%	0.0%	0.0%	0.0%	0.0%	0.0%	0.0%	0.4%	0.0%	0.2%	0.0%	0.0%	0.0%	0.0%	0.0%	0.0%	0.0%	0.0%	0.0%	0.0%											
Buses	0	0	0	0	0	0	15	0	0	15	3	3	3	0	9	0	9	4	0	13	0	0	0	0	0	0	0	0	0	0											
% Buses	0.0%	0.0%	0.0%	0.0%	0.0%	0.0%	6.8%	0.0%	0.0%	6.5%	3.1%	2.1%	6.7%	0.0%	3.3%	0.0%	5.8%	1.6%	0.0%	3.3%	0.0%	0.0%	0.0%	0.0%	0.0%	0.0%	0.0%	0.0%	0.0%	0.0%											
Pedestrians	0	0	0	0	0	0	0	0	0	0	0	0	0	0	0	0	0	0	0	0	0	0	0	0	0	0	0	0	0	0											
% Pedestrians	0.0%	0.0%	0.0%	0.0%	0.0%	100.0%	33.3%	0.0%	0.0%	0.0%	0.0%	0.0%	0.0%	0.0%	0.0%	0.0%	0.0%	0.0%	0.0%	0.0%	0.0%	0.0%	0.0%	0.0%	0.0%	0.0%	0.0%	0.0%	0.0%	0.0%											
Bicycles on Crosswalk	0	0	0	0	0	0	2	0	0	2	0	0	0	0	0	0	0	0	0	0	0	0	0	0	0	0	0	0	0	0											
% Bicycles on Crosswalk	0.0%	0.0%	0.0%	0.0%	0.0%	0.0%	0.9%	0.0%	0.0%	0.9%	0.0%	0.0%	0.0%	0.0%	0.0%	0.0%	0.0%	0.0%	0.0%	0.0%	0.0%	0.0%	0.0%	0.0%	0.0%	0.0%	0.0%	0.0%	0.0%	0.0%											

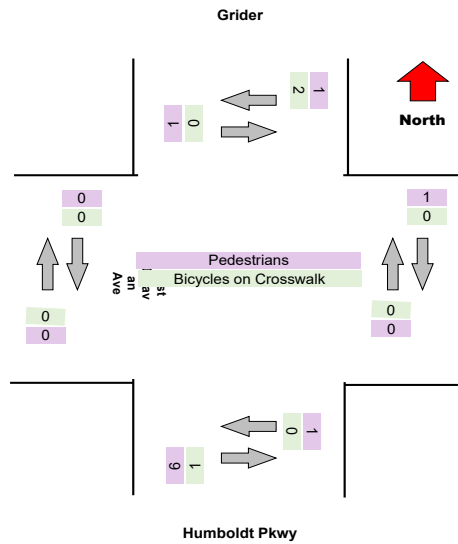
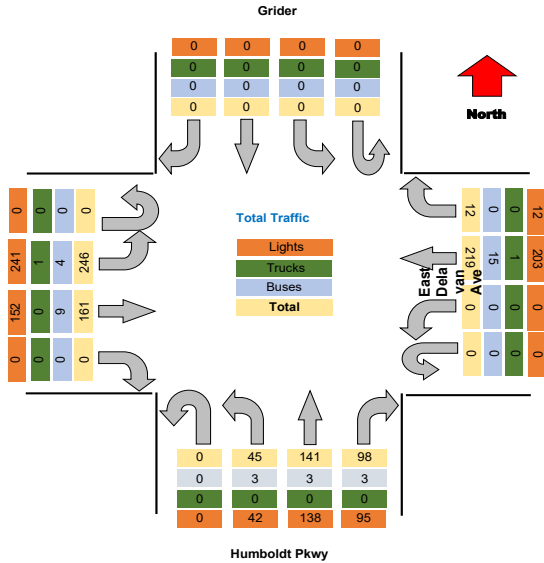

**Turning Movement Peak Hour Data (PM)**

4:30:00 PM

Leg Direction	Grider										East Delavan Ave										Humboldt Pkwy										East Delavan Ave										Total
	Southbound					Northbound					Westbound					Eastbound					Northbound					Eastbound															
	Right	Thru	Left	U-Turn	App Total	Peds CW	Peds CCW	Right	Thru	Left	U-Turn	App Total	Peds CW	Peds CCW	Right	Thru	Left	U-Turn	App Total	Peds CW	Peds CCW	Right	Thru	Left	U-Turn	App Total	Peds CW	Peds CCW													
4:30:00 PM	0	0	0	0	0	0	0	0	0	0	9	69	0	0	78	0	0	0	0	0	40	37	14	0	91	3	2	0	0	5	0	85	60	0	145	0	0	0	0	0	314
4:45:00 PM	0	0	0	0	0	0	1	0	0	1	4	80	0	0	84	0	0	0	0	0	33	44	12	0	89	1	0	0	0	1	0	51	55	0	106	0	0	0	0	0	279
5:00:00 PM	0	0	0	0	0	0	0	0	0	0	6	58	0	0	64	0	0	0	0	0	28	59	18	0	105	1	1	0	0	2	0	41	56	0	97	0	0	0	0	0	266
5:15:00 PM	0	0	0	0	0	0	0	0	0	0	4	60	0	0	64	0	0	0	0	0	42	41	15	0	98	0	0	0	0	0	0	62	51	0	123	2	2	0	0	4	285
<b>Grand Total</b>	0	0	0	0	0	0	1	0	0	1	23	257	0	0	280	0	0	0	0	0	143	191	59	0	393	5	2	0	0	7	0	239	222	0	471	2	2	0	0	4	1144
<b>% Approach</b>	#DIV/0!	#DIV/0!	#DIV/0!	#DIV/0!	0.0%	0.0%	0.0%	0.0%	0.0%	0.0%	14.2%	85.8%	0.0%	0.0%	0.0%	0.0%	0.0%	0.0%	0.0%	0.0%	45.1%	41.7%	13.2%	0.0%	0.0%	0.0%	0.0%	0.0%	0.0%	0.0%	0.0%	66.2%	33.8%	0.0%	0.0%	0.0%	0.0%	0.0%	0.0%	0.0%	
<b>% Total</b>	0.0%	0.0%	0.0%	0.0%	0.0%	0.0%	0.0%	0.0%	0.0%	0.0%	2.0%	23.3%	0.0%	0.0%	25.3%	0.0%	0.0%	0.0%	0.0%	0.0%	12.5%	15.8%	5.2%	0.0%	33.5%	0.0%	0.0%	0.0%	0.0%	0.0%	0.0%	20.9%	20.3%	0.0%	41.2%	0.0%	0.0%	0.0%	0.0%	0.0%	
<b>PHF</b>	0.000	0.000	0.000	0.000	0.000	0.000	0.000	0.000	0.000	0.000	0.639	0.834	0.000	0.000	0.863	0.000	0.000	0.000	0.000	0.000	0.851	0.767	0.819	0.000	0.812	0.000	0.000	0.000	0.000	0.000	0.000	0.703	0.951	0.000	0.812	0.000	0.000	0.000	0.000	0.000	
<b>Lights</b>	0	0	0	0	0	0	0	0	0	0	23	258	0	0	281	0	0	0	0	0	143	180	59	0	382	0	0	0	0	0	0	231	228	0	459	0	0	0	0	0	1122
<b>% Lights</b>	0.0%	0.0%	0.0%	0.0%	0.0%	0.0%	0.0%	0.0%	0.0%	0.0%	100.0%	96.6%	0.0%	0.0%	96.9%	0.0%	0.0%	0.0%	0.0%	0.0%	100.0%	99.4%	100.0%	0.0%	99.7%	0.0%	0.0%	0.0%	0.0%	0.0%	0.0%	96.7%	98.3%	0.0%	97.5%	0.0%	0.0%	0.0%	0.0%	0.0%	
<b>Trucks</b>	0	0	0	0	0	0	0	0	0	0	0	0	0	0	0	0	0	0	0	0	0	0	0	0	0	0	0	0	0	0	0	0	0	0	0	0	0	0	0	0	0
<b>% Trucks</b>	0.0%	0.0%	0.0%	0.0%	0.0%	0.0%	0.0%	0.0%	0.0%	0.0%	0.0%	0.0%	0.0%	0.0%	0.0%	0.0%	0.0%	0.0%	0.0%	0.0%	0.0%	0.0%	0.0%	0.0%	0.0%	0.0%	0.0%	0.0%	0.0%	0.0%	0.0%	0.0%	0.0%	0.0%	0.0%	0.0%	0.0%	0.0%	0.0%	0.0%	
<b>Buses</b>	0	0	0	0	0	0	0	0	0	0	0	8	0	0	8	0	0	0	0	0	0	1	0	0	1	0	0	0	0	0	0	8	4	0	12	0	0	0	0	0	21
<b>% Buses</b>	0.0%	0.0%	0.0%	0.0%	0.0%	0.0%	0.0%	0.0%	0.0%	0.0%	0.0%	3.0%	0.0%	0.0%	0.0%	0.0%	0.0%	0.0%	0.0%	0.0%	0.0%	0.8%	0.0%	0.0%	0.0%	0.0%	0.0%	0.0%	0.0%	0.0%	0.0%	3.3%	1.7%	0.0%	0.0%	0.0%	0.0%	0.0%	0.0%	0.0%	
<b>Pedestrians</b>	0	0	0	0	0	0	1	0	0	1	0	0	0	0	0	0	0	0	0	0	0	0	0	0	0	5	3	0	0	8	0	0	0	0	0	2	2	0	0	4	
<b>% Pedestrians</b>	0.0%	0.0%	0.0%	0.0%	0.0%	0.0%	100.0%	0.0%	0.0%	0.0%	0.0%	0.0%	0.0%	0.0%	0.0%	0.0%	0.0%	0.0%	0.0%	0.0%	0.0%	0.0%	0.0%	0.0%	0.0%	100.0%	100.0%	0.0%	0.0%	0.0%	100.0%	100.0%	0.0%	0.0%	0.0%						
<b>Bicycles on Crosswalk</b>	0	0	0	0	0	0	0	0	0	0	0	0	0	0	0	0	0	0	0	0	0	0	0	0	0	0	0	0	0	0	0	0	0	0	0	0	0	0	0	0	0
<b>% Bicycles on Crosswalk</b>	0.0%	0.0%	0.0%	0.0%	0.0%	0.0%	0.0%	0.0%	0.0%	0.0%	0.0%	0.0%	0.0%	0.0%	0.0%	0.0%	0.0%	0.0%	0.0%	0.0%	0.0%	0.0%	0.0%	0.0%	0.0%	0.0%	0.0%	0.0%	0.0%	0.0%	0.0%	0.0%	0.0%	0.0%	0.0%	0.0%	0.0%	0.0%	0.0%	0.0%	

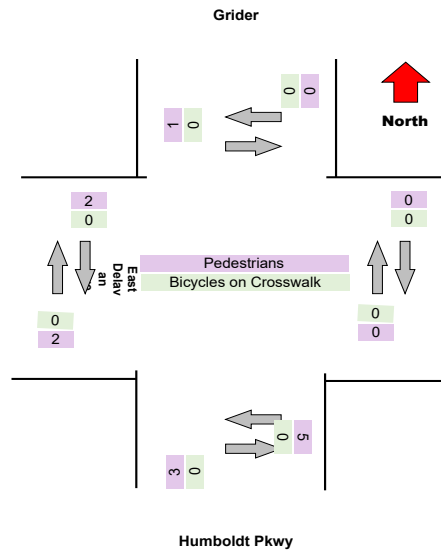
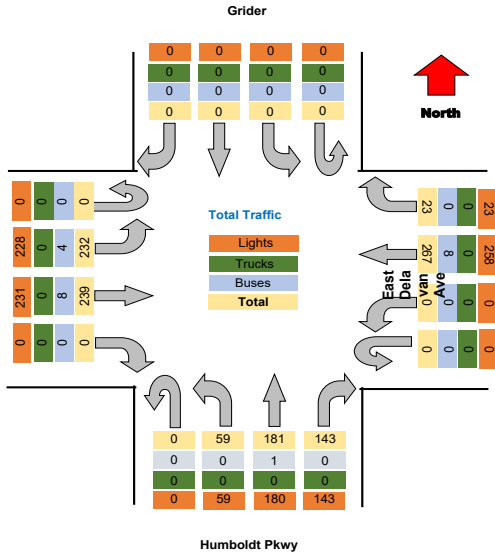



Project : VBH Malta NY  
 Site : Site 4  
 Location : 42.948550, -73.790036  
 Survey Date : 2021-04-28, Wednesday

### Turning Movement Data Plot

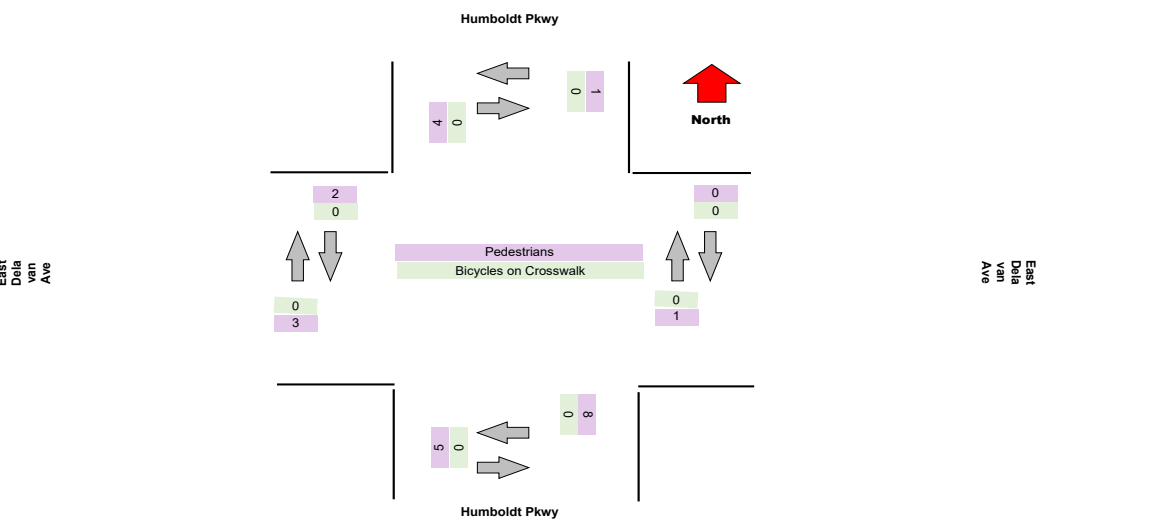
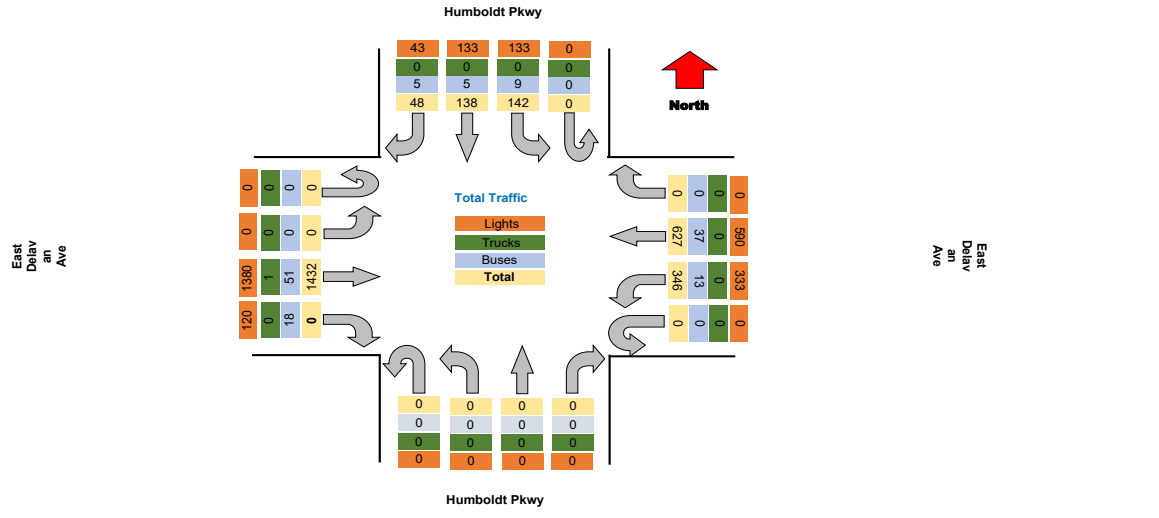



**Turning Movement Peak Hour Data (AM)**

7:30:00 AM

Leg Direction	Humboldt Pkwy					East Delavan Ave					Humboldt Pkwy					East Delavan Ave					Total	
	Southbound		Westbound			Northbound		Eastbound			Southbound		Westbound			Northbound		Eastbound				
Start Time	Right	Thru	Left	U-Turn	App Total	Peds CW	Peds CCW	Right	Thru	Left	U-Turn	App Total	Peds CW	Peds CCW	Right	Thru	Left	U-Turn	App Total	Peds CW	Peds CCW	
7:30:00 AM	1	6	12	0	19	0	0	0	35	18	0	53	0	0	0	0	0	0	0	0	0	0
7:45:00 AM	1	4	9	0	14	0	0	0	36	17	0	53	0	0	0	0	0	0	0	6	108	0
8:00:00 AM	1	5	4	0	10	0	0	0	48	25	0	73	0	0	0	0	0	0	1	0	0	0
8:15:00 AM	3	7	3	0	13	0	0	0	44	25	0	69	0	0	0	0	0	0	0	9	114	0
<b>Grand Total</b>	<b>6</b>	<b>22</b>	<b>33</b>	<b>0</b>	<b>61</b>	<b>0</b>	<b>0</b>	<b>0</b>	<b>153</b>	<b>88</b>	<b>0</b>	<b>251</b>	<b>0</b>	<b>0</b>	<b>0</b>	<b>0</b>	<b>0</b>	<b>0</b>	<b>1</b>	<b>25</b>	<b>395</b>	<b>0</b>
<b>% Approach</b>	9.8%	36.1%	54.1%	0.0%	0.0%	0.0%	0.0%	14.2%	85.8%	0.0%	0.0%	0.0%	0.0%	0.0%	45.1%	41.7%	13.2%	0.0%	0.0%	0.0%	0.0%	0.0%
<b>% Total</b>	0.8%	3.0%	4.5%	0.0%	8.3%	0.0%	0.0%	0.0%	22.2%	12.0%	0.0%	34.2%	0.0%	0.0%	0.0%	0.0%	0.0%	0.0%	0.0%	3.4%	54.0%	0.0%
<b>PHF</b>	0.500	0.786	0.688	0.000	0.803	0.000	0.000	0.000	0.849	0.786	0.000	0.826	0.000	0.000	0.000	0.000	0.000	0.000	0.000	0.694	0.868	0.000
<b>Lights</b>	5	21	31	0	57	0	0	0	150	87	0	237	0	0	0	0	0	0	0	21	386	0
<b>% Lights</b>	83.3%	85.5%	93.9%	0.0%	93.4%	0.0%	0.0%	0.0%	92.0%	98.9%	0.0%	94.4%	0.0%	0.0%	0.0%	0.0%	0.0%	0.0%	0.0%	84.0%	97.5%	0.0%
<b>Trucks</b>	0	0	0	0	0	0	0	0	0	0	0	0	0	0	0	0	0	0	0	0	1	0
<b>% Trucks</b>	0.0%	0.0%	0.0%	0.0%	0.0%	0.0%	0.0%	0.0%	0.0%	0.0%	0.0%	0.0%	0.0%	0.0%	0.0%	0.0%	0.0%	0.0%	0.0%	0.0%	0.3%	0.0%
<b>Buses</b>	1	1	2	0	4	0	0	0	13	1	0	14	0	0	0	0	0	0	0	4	9	0
<b>% Buses</b>	16.7%	4.5%	6.1%	0.0%	6.6%	0.0%	0.0%	0.0%	8.0%	1.1%	0.0%	5.0%	0.0%	0.0%	0.0%	0.0%	0.0%	0.0%	0.0%	16.0%	2.3%	0.0%
<b>Pedestrians</b>	0	0	0	0	0	0	0	0	0	0	0	0	0	0	1	0	0	0	0	0	0	0
<b>% Pedestrians</b>	0.0%	0.0%	0.0%	0.0%	0.0%	0.0%	0.0%	0.0%	0.0%	0.0%	0.0%	0.0%	0.0%	0.0%	0.0%	0.0%	0.0%	0.0%	0.0%	0.0%	0.0%	0.0%
<b>Bicycles on Crosswalk</b>	0	0	0	0	0	0	0	0	0	0	0	0	0	0	0	0	0	0	0	0	0	0
<b>% Bicycles on Crosswalk</b>	0.0%	0.0%	0.0%	0.0%	0.0%	0.0%	0.0%	0.0%	0.0%	0.0%	0.0%	0.0%	0.0%	0.0%	0.0%	0.0%	0.0%	0.0%	0.0%	0.0%	0.0%	0.0%

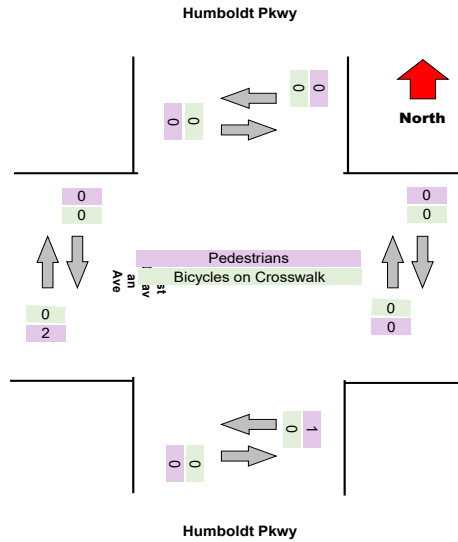
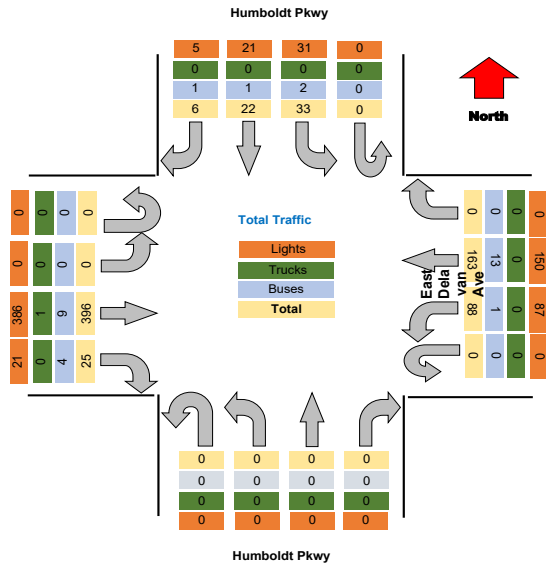

### Turning Movement Peak Hour Data (PM)

4:30:00 PM

Leg Direction	Humboldt Pkwy								East Delavan Ave								Total					
	Southbound				Westbound				Northbound				Eastbound									
Start Time	Right	Thru	Left	U-Turn	App Total	Peds CW	Peds CCW	Right	Thru	Left	U-Turn	App Total	Peds CW	Peds CCW	Right	Thru	Left	U-Turn	App Total	Peds CW	Peds CCW	
4:30:00 PM	3	11	16	0	30	0	0	0	47	29	0	76	0	0	0	0	0	0	134	1	0	
4:45:00 PM	6	15	13	0	34	0	0	0	60	23	0	83	0	0	0	0	0	1	111	90	0	
5:00:00 PM	2	17	11	0	30	3	0	0	45	25	0	70	0	0	0	0	0	10	82	0	0	
5:15:00 PM	8	14	18	0	41	0	0	0	44	21	0	65	0	0	0	0	0	9	103	0	0	
<b>Grand Total</b>	<b>20</b>	<b>57</b>	<b>58</b>	<b>0</b>	<b>135</b>	<b>3</b>	<b>0</b>	<b>0</b>	<b>196</b>	<b>98</b>	<b>0</b>	<b>294</b>	<b>0</b>	<b>0</b>	<b>0</b>	<b>0</b>	<b>0</b>	<b>48</b>	<b>391</b>	<b>0</b>	<b>0</b>	
<b>% Approach</b>	14.8%	42.2%	43.0%	0.0%	0.0%	0.0%	0.0%	14.2%	85.8%	0.0%	0.0%	0.0%	0.0%	0.0%	45.1%	41.7%	13.2%	0.0%	0.0%	0.0%	0.0%	0.0%
<b>% Total</b>	2.3%	6.6%	6.7%	0.0%	15.6%	0.0%	0.0%	0.0%	22.6%	11.3%	0.0%	33.9%	0.0%	0.0%	0.0%	0.0%	0.0%	0.0%	5.5%	45.0%	0.0%	0.0%
<b>PHF</b>	0.556	0.838	0.806	0.000	0.823	0.000	0.000	0.000	0.817	0.845	0.000	0.886	0.000	0.000	0.000	0.000	0.000	0.000	0.667	0.843	0.000	0.000
<b>Lights</b>	18	55	55	0	128	0	0	0	187	98	0	285	0	0	0	0	0	0	41	380	0	0
<b>% Lights</b>	80.0%	96.5%	94.8%	0.0%	94.8%	0.0%	0.0%	0.0%	95.4%	100.0%	0.0%	96.9%	0.0%	0.0%	0.0%	0.0%	0.0%	0.0%	85.4%	97.2%	0.0%	0.0%
<b>Trucks</b>	0	0	0	0	0	0	0	0	0	0	0	0	0	0	0	0	0	0	0	0	0	0
<b>% Trucks</b>	0.0%	0.0%	0.0%	0.0%	0.0%	0.0%	0.0%	0.0%	0.0%	0.0%	0.0%	0.0%	0.0%	0.0%	0.0%	0.0%	0.0%	0.0%	0.0%	0.0%	0.0%	0.0%
<b>Buses</b>	2	2	3	0	7	0	0	0	9	0	0	9	0	0	0	0	0	0	7	11	0	0
<b>% Buses</b>	10.0%	3.5%	5.2%	0.0%	0.0%	0.0%	0.0%	0.0%	4.6%	0.0%	0.0%	3.0%	0.0%	0.0%	0.0%	0.0%	0.0%	0.0%	14.6%	2.8%	0.0%	0.0%
<b>Pedestrians</b>	0	0	0	0	0	3	0	0	0	0	0	0	3	2	0	0	0	0	0	0	1	0
<b>% Pedestrians</b>	0.0%	0.0%	0.0%	0.0%	0.0%	100.0%	0.0%	0.0%	0.0%	0.0%	0.0%	0.0%	100.0%	100.0%	0.0%	0.0%	0.0%	0.0%	0.0%	0.0%	100.0%	0.0%
<b>Bicycles on Crosswalk</b>	0	0	0	0	0	0	0	0	0	0	0	0	0	0	0	0	0	0	0	0	0	0
<b>% Bicycles on Crosswalk</b>	0.0%	0.0%	0.0%	0.0%	0.0%	0.0%	0.0%	0.0%	0.0%	0.0%	0.0%	0.0%	0.0%	0.0%	0.0%	0.0%	0.0%	0.0%	0.0%	0.0%	0.0%	0.0%

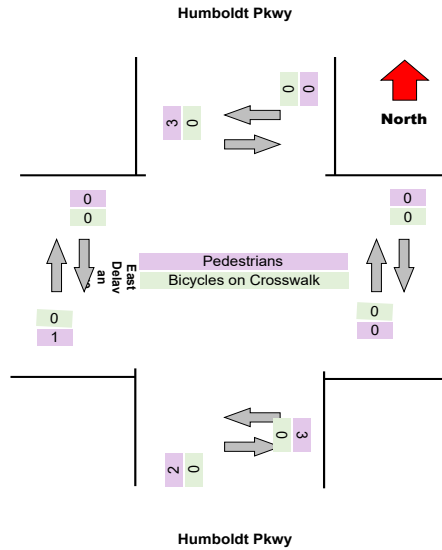
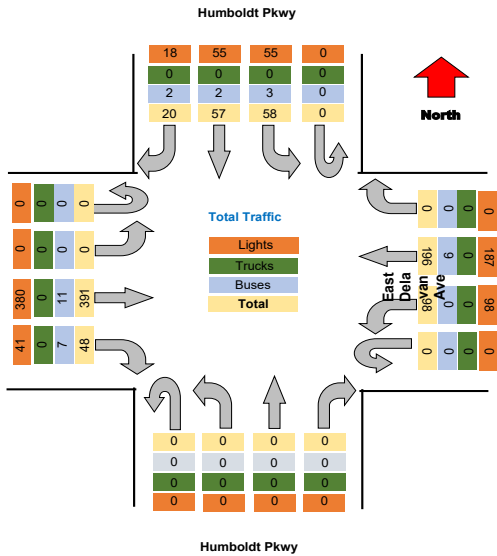



Project : VBH Malta NY  
 Site : Site 4  
 Location : 42.948550, -73.790036  
 Survey Date : 2021-04-28, Wednesday

### Turning Movement Data Plot

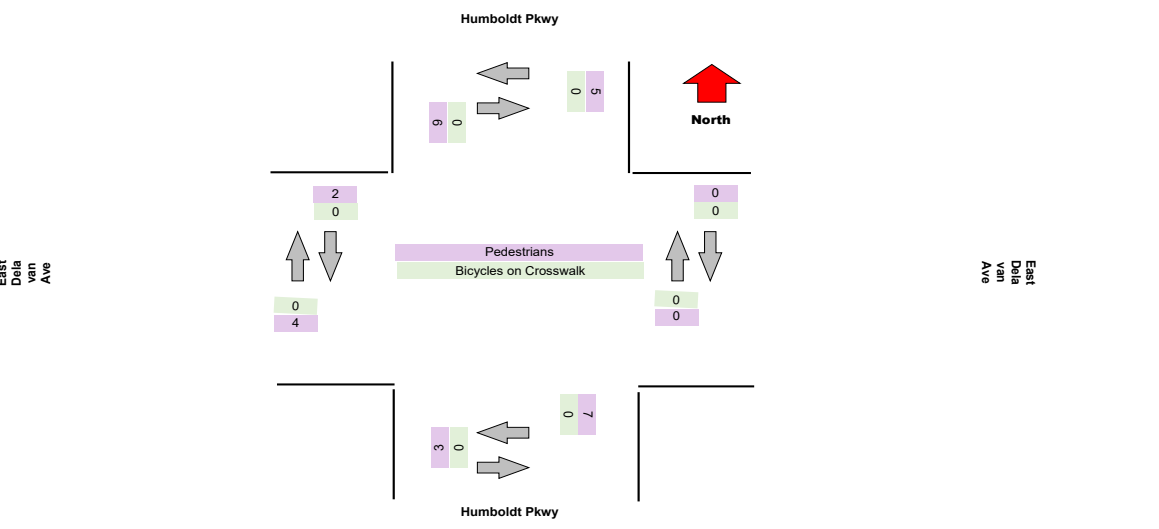
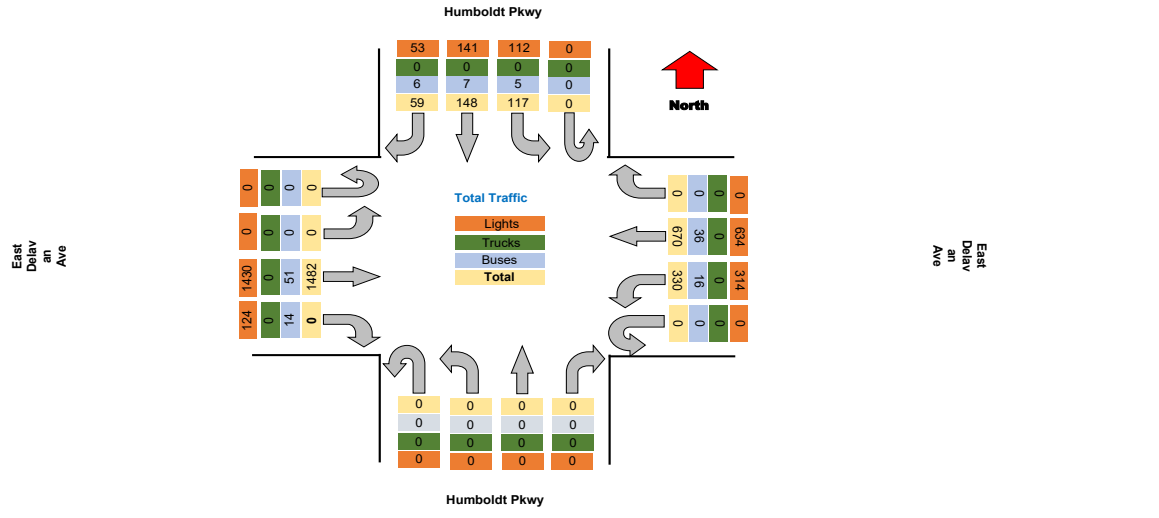

Project : VBH Malta NY  
Site : Site 4  
Location : 42.948550, -73.790036

TSTData.com

Survey Date : 2021-04-28, Wednesday

### Turning Movement Peak Hour Data (AM)

7:30:00 AM

Leg Direction	Humboldt Pkwy					East Delavan Ave					Humboldt Pkwy					East Delavan Ave					Total						
	Southbound		Westbound			Northbound		Eastbound																			
Start Time	Right	Thru	Left	U-Turn	App Total	Peds CW	Peds CCW	Right	Thru	Left	U-Turn	App Total	Peds CW	Peds CCW	Right	Thru	Left	U-Turn	App Total	Peds CW	Peds CCW						
7:30:00 AM	4	3	9	0	16	1	0	0	29	16	0	45	0	0	0	0	0	0	0	9	96	0	105	1	0	166	
7:45:00 AM	1	8	9	0	18	0	0	0	43	25	0	68	0	0	0	0	0	0	0	5	93	0	98	0	0	184	
8:00:00 AM	3	7	4	0	14	1	0	0	45	19	0	64	0	0	0	0	0	0	0	6	91	0	97	0	0	175	
8:15:00 AM	3	9	3	0	15	0	0	0	39	20	0	59	0	0	0	0	0	0	0	5	100	0	105	0	0	180	
<b>Grand Total</b>	<b>11</b>	<b>27</b>	<b>25</b>	<b>0</b>	<b>63</b>	<b>2</b>	<b>0</b>	<b>0</b>	<b>156</b>	<b>80</b>	<b>0</b>	<b>237</b>	<b>0</b>	<b>0</b>	<b>0</b>	<b>0</b>	<b>0</b>	<b>0</b>	<b>0</b>	<b>25</b>	<b>380</b>	<b>0</b>	<b>405</b>	<b>1</b>	<b>0</b>	<b>705</b>	
% Approach	17.5%	42.2%	39.7%	0.0%	0.0%	0.0%	0.0%	14.2%	85.8%	0.0%	0.0%	0.0%	0.0%	0.0%	45.1%	41.7%	13.2%	0.0%	0.0%	0.0%	66.2%	33.8%	0.0%	0.0%	0.0%	0.0%	0.0%
% Total	1.6%	3.8%	3.5%	0.0%	8.3%	0.0%	0.0%	0.0%	22.1%	11.3%	0.0%	33.6%	0.0%	0.0%	0.0%	0.0%	0.0%	0.0%	0.0%	3.5%	53.9%	0.0%	67.4%	0.0%	0.0%	0.0%	
PHF	0.688	0.750	0.694	0.000	0.875	0.000	0.000	0.000	0.887	0.800	0.000	0.871	0.000	0.000	0.000	0.000	0.000	0.000	0.000	0.694	0.950	0.000	0.964	0.000	0.000	0.958	
Lights	10	25	25	0	60	0	0	0	142	77	0	219	0	0	0	0	0	0	0	21	368	0	389	0	0	668	
% Lights	80.9%	82.6%	100.0%	0.0%	95.2%	0.0%	0.0%	0.0%	91.0%	96.3%	0.0%	92.4%	0.0%	0.0%	0.0%	0.0%	0.0%	0.0%	0.0%	84.0%	96.8%	0.0%	96.0%	0.0%	0.0%	94.8%	
Trucks	0	0	0	0	0	0	0	0	0	0	0	0	0	0	0	0	0	0	0	0	0	0	0	0	0	0	
% Trucks	0.0%	0.0%	0.0%	0.0%	0.0%	0.0%	0.0%	0.0%	0.0%	0.0%	0.0%	0.0%	0.0%	0.0%	0.0%	0.0%	0.0%	0.0%	0.0%	0.0%	0.0%	0.0%	0.0%	0.0%	0.0%	0.0%	
Buses	1	2	0	0	3	0	0	0	14	3	0	17	0	0	0	0	0	0	0	4	12	0	16	0	0	36	
% Buses	3.1%	7.4%	0.0%	0.0%	0.0%	0.0%	0.0%	0.0%	9.0%	3.8%	0.0%	0.0%	0.0%	0.0%	0.0%	0.0%	0.0%	0.0%	0.0%	16.0%	3.2%	0.0%	0.0%	0.0%	0.0%	5.1%	
Pedestrians	0	0	0	0	0	2	1	0	0	0	0	0	0	0	0	0	0	0	0	0	0	0	0	1	0	0	
% Pedestrians	0.0%	0.0%	0.0%	0.0%	0.0%	100.0%	100.0%	0.0%	0.0%	0.0%	0.0%	0.0%	0.0%	0.0%	0.0%	0.0%	0.0%	0.0%	0.0%	0.0%	0.0%	0.0%	0.0%	100.0%	0.0%	0.0%	
Bicycles on Crosswalk	0	0	0	0	0	0	0	0	0	0	0	0	0	0	0	0	0	0	0	0	0	0	0	0	0	0	
% Bicycles on Crosswalk	0.0%	0.0%	0.0%	0.0%	0.0%	0.0%	0.0%	0.0%	0.0%	0.0%	0.0%	0.0%	0.0%	0.0%	0.0%	0.0%	0.0%	0.0%	0.0%	0.0%	0.0%	0.0%	0.0%	0.0%	0.0%	0.0%	

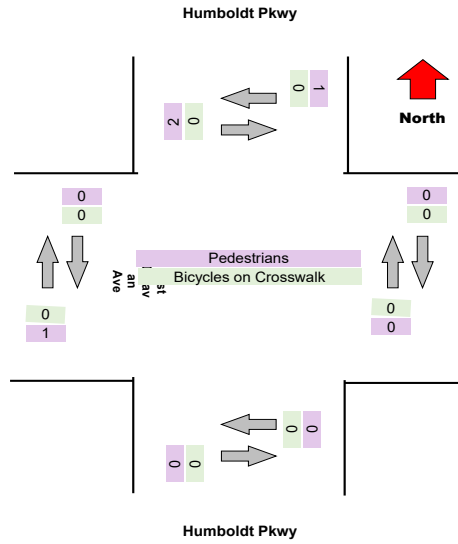
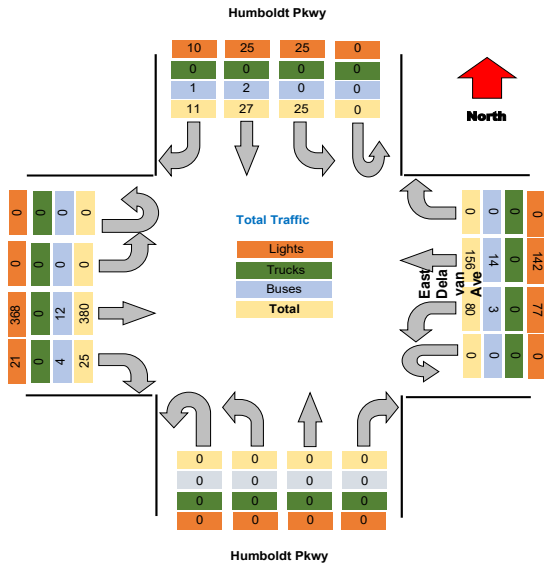

**Turning Movement Peak Hour Data (PM)**

4:30:00 PM

Leg Direction	Humboldt Pkwy										East Delavan Ave										Total									
	Southbound					Westbound					Northbound					Eastbound														
	Right	Thru	Left	U-Turn	App Total	Peds CW	Peds CCW	Right	Thru	Left	U-Turn	App Total	Peds CW	Peds CCW	Right	Thru	Left	U-Turn	App Total	Peds CW		Peds CCW								
4:30:00 PM	6	17	9	0	32	0	0	0	57	26	0	83	0	0	0	0	0	0	0	4	1	8	112	0	0	120	0	1	235	
4:45:00 PM	4	15	11	0	30	0	0	0	53	25	0	78	0	0	0	0	0	0	0	0	0	8	107	0	0	115	1	0	223	
5:00:00 PM	6	13	10	0	29	1	0	0	53	19	0	72	0	0	0	0	0	0	0	0	0	12	91	0	0	103	1	1	204	
5:15:00 PM	6	9	6	0	21	1	0	0	55	22	0	77	0	0	0	0	0	0	0	0	0	16	104	0	0	120	0	0	219	
<b>Grand Total</b>	<b>22</b>	<b>54</b>	<b>36</b>	<b>0</b>	<b>112</b>	<b>2</b>	<b>0</b>	<b>0</b>	<b>219</b>	<b>92</b>	<b>0</b>	<b>311</b>	<b>0</b>	<b>0</b>	<b>0</b>	<b>0</b>	<b>0</b>	<b>0</b>	<b>4</b>	<b>1</b>	<b>44</b>	<b>414</b>	<b>0</b>	<b>0</b>	<b>438</b>	<b>2</b>	<b>2</b>	<b>881</b>		
<b>% Approach</b>	19.6%	48.2%	32.1%	0.0%	0.0%	0.0%	0.0%	14.2%	85.8%	0.0%	0.0%	0.0%	0.0%	0.0%	45.1%	41.7%	13.2%	0.0%	0.0%	0.0%	0.0%	0.0%	66.2%	33.8%	0.0%	0.0%	0.0%	0.0%	0.0%	
<b>% Total</b>	2.5%	6.1%	4.1%	0.0%	12.7%	0.0%	0.0%	0.0%	24.9%	10.4%	0.0%	35.3%	0.0%	0.0%	0.0%	0.0%	0.0%	0.0%	0.0%	0.0%	0.0%	5.0%	47.0%	0.0%	0.0%	52.0%	0.0%	0.0%		
<b>PHF</b>	0.917	0.794	0.818	0.000	0.875	0.000	0.000	0.000	0.961	0.885	0.000	0.937	0.000	0.000	0.000	0.000	0.000	0.000	0.000	0.000	0.000	0.688	0.924	0.000	0.000	0.954	0.000	0.000	0.937	
<b>Lights</b>	19	53	34	0	106	0	0	0	212	90	0	302	0	0	0	0	0	0	0	0	0	42	405	0	0	447	0	0	855	
<b>% Lights</b>	86.4%	98.1%	94.4%	0.0%	94.6%	0.0%	0.0%	0.0%	96.8%	97.8%	0.0%	97.1%	0.0%	0.0%	0.0%	0.0%	0.0%	0.0%	0.0%	0.0%	0.0%	95.5%	97.8%	0.0%	0.0%	97.6%	0.0%	0.0%	97.0%	
<b>Trucks</b>	0	0	0	0	0	0	0	0	0	0	0	0	0	0	0	0	0	0	0	0	0	0	0	0	0	0	0	0	0	
<b>% Trucks</b>	0.0%	0.0%	0.0%	0.0%	0.0%	0.0%	0.0%	0.0%	0.0%	0.0%	0.0%	0.0%	0.0%	0.0%	0.0%	0.0%	0.0%	0.0%	0.0%	0.0%	0.0%	0.0%	0.0%	0.0%	0.0%	0.0%	0.0%	0.0%	0.0%	
<b>Buses</b>	3	1	2	0	6	0	0	0	7	2	0	9	0	0	0	0	0	0	0	0	0	2	9	0	0	11	0	0	26	
<b>% Buses</b>	13.6%	1.9%	5.6%	0.0%	0.0%	0.0%	0.0%	0.0%	3.2%	2.2%	0.0%	0.0%	0.0%	0.0%	0.0%	0.0%	0.0%	0.0%	0.0%	0.0%	0.0%	4.5%	2.2%	0.0%	0.0%	0.0%	0.0%	0.0%	3.0%	
<b>Pedestrians</b>	0	0	0	0	0	2	1	0	0	0	0	0	0	0	0	4	1	0	0	0	0	0	0	0	0	0	2	2	0	
<b>% Pedestrians</b>	0.0%	0.0%	0.0%	0.0%	0.0%	100.0%	100.0%	0.0%	0.0%	0.0%	0.0%	0.0%	0.0%	0.0%	0.0%	100.0%	100.0%	0.0%	0.0%	0.0%	0.0%	0.0%	0.0%	0.0%	0.0%	0.0%	0.0%	100.0%	100.0%	0.0%
<b>Bicycles on Crosswalk</b>	0	0	0	0	0	0	0	0	0	0	0	0	0	0	0	0	0	0	0	0	0	0	0	0	0	0	0	0	0	
<b>% Bicycles on Crosswalk</b>	0.0%	0.0%	0.0%	0.0%	0.0%	0.0%	0.0%	0.0%	0.0%	0.0%	0.0%	0.0%	0.0%	0.0%	0.0%	0.0%	0.0%	0.0%	0.0%	0.0%	0.0%	0.0%	0.0%	0.0%	0.0%	0.0%	0.0%	0.0%	0.0%	

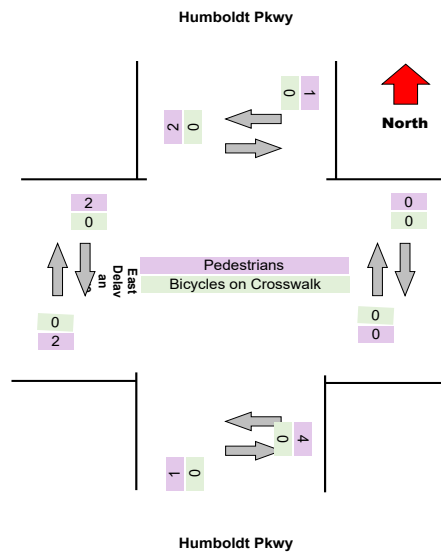
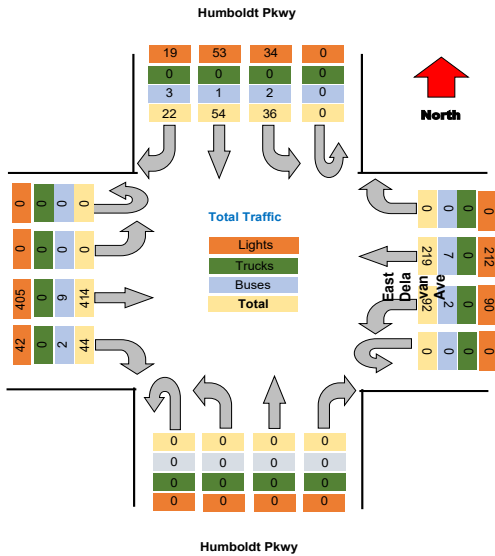



Project : VBH Malta NY  
 Site : Site 4  
 Location : 42.948550, -73.790036  
 Survey Date : 2021-04-28, Wednesday

### Turning Movement Data Plot

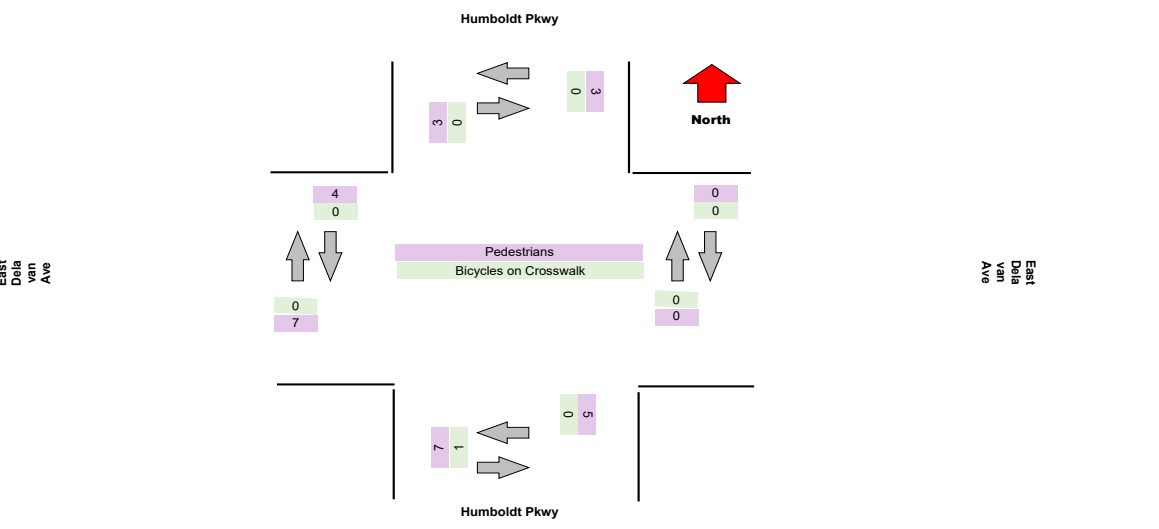
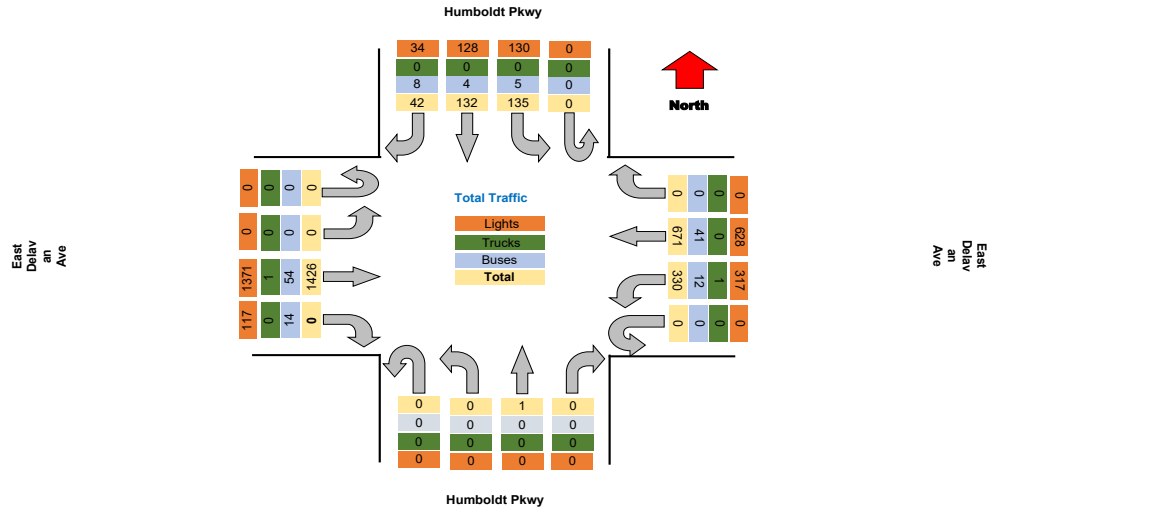



Project : VBH Malta NY  
Site : Site 4  
Location : 42.948550, -73.790036  
Survey Date : 2021-04-28, Wednesday

TSTData.com

**Turning Movement Peak Hour Data (AM)**

7:30:00 AM

Leg Direction	Humboldt Pkwy					East Delavan Ave					Humboldt Pkwy					East Delavan Ave					Total								
	Southbound		Westbound			Northbound		Eastbound			Southbound		Westbound			Northbound		Eastbound											
Start Time	Right	Thru	Left	U-Turn	App Total	Peds CW	Peds CCW	Right	Thru	Left	U-Turn	App Total	Peds CW	Peds CCW	Right	Thru	Left	U-Turn	App Total	Peds CW	Peds CCW	Right	Thru	Left	U-Turn	App Total	Peds CW	Peds CCW	
7:30:00 AM	4	5	9	0	18	0	0	0	31	21	0	52	0	0	0	0	0	0	0	0	0	0	6	92	0	0	98	0	0
7:45:00 AM	0	10	6	0	16	1	0	0	52	23	0	75	0	0	0	0	0	0	0	0	0	4	107	0	0	111	0	0	
8:00:00 AM	2	2	4	0	8	0	0	0	44	26	0	70	0	0	0	0	0	0	0	0	0	8	90	0	0	98	0	0	
8:15:00 AM	1	11	8	0	20	0	0	0	41	23	0	65	0	0	0	0	0	0	0	0	0	4	91	0	0	95	0	0	
<b>Grand Total</b>	<b>7</b>	<b>28</b>	<b>27</b>	<b>0</b>	<b>62</b>	<b>1</b>	<b>0</b>	<b>0</b>	<b>168</b>	<b>95</b>	<b>0</b>	<b>264</b>	<b>0</b>	<b>0</b>	<b>0</b>	<b>0</b>	<b>0</b>	<b>0</b>	<b>0</b>	<b>0</b>	<b>0</b>	<b>22</b>	<b>366</b>	<b>0</b>	<b>0</b>	<b>492</b>	<b>0</b>	<b>0</b>	
% Approach	11.3%	45.2%	43.5%	0.0%	0.0%	0.0%	0.0%	14.2%	85.8%	0.0%	0.0%	0.0%	0.0%	0.0%	45.1%	41.7%	13.2%	0.0%	0.0%	0.0%	0.0%	0.0%	66.2%	33.8%	0.0%	0.0%	0.0%	0.0%	
% Total	1.0%	3.8%	3.7%	0.0%	8.5%	0.0%	0.0%	0.0%	23.1%	13.0%	0.0%	36.3%	0.0%	0.0%	0.0%	0.0%	0.0%	0.0%	0.0%	0.0%	0.0%	3.0%	52.2%	0.0%	0.0%	55.2%	0.0%	0.0%	
PHF	0.438	0.636	0.750	0.000	0.775	0.000	0.000	0.000	0.808	0.848	0.000	0.890	0.000	0.000	0.000	0.000	0.000	0.000	0.000	0.000	0.000	0.688	0.888	0.000	0.000	0.905	0.000	0.000	
Lights	6	27	27	0	60	0	0	0	152	92	0	244	0	0	0	0	0	0	0	0	0	18	366	0	0	384	0	0	
% Lights	85.7%	96.4%	100.0%	0.0%	96.8%	0.0%	0.0%	0.0%	90.5%	96.8%	0.0%	92.4%	0.0%	0.0%	0.0%	0.0%	0.0%	0.0%	0.0%	0.0%	0.0%	81.8%	96.3%	0.0%	0.0%	95.5%	0.0%	0.0%	
Trucks	0	0	0	0	0	0	0	0	0	1	0	1	0	0	0	0	0	0	0	0	0	0	1	0	0	1	0	0	
% Trucks	0.0%	0.0%	0.0%	0.0%	0.0%	0.0%	0.0%	0.0%	0.0%	1.1%	0.0%	0.4%	0.0%	0.0%	0.0%	0.0%	0.0%	0.0%	0.0%	0.0%	0.0%	0.0%	0.3%	0.0%	0.0%	0.2%	0.0%	0.0%	
Buses	1	1	0	0	2	0	0	0	16	2	0	18	0	0	0	0	0	0	0	0	0	4	13	0	0	17	0	0	
% Buses	14.3%	3.6%	0.0%	0.0%	0.0%	0.0%	0.0%	0.0%	9.5%	2.1%	0.0%	0.0%	0.0%	0.0%	0.0%	0.0%	0.0%	0.0%	0.0%	0.0%	0.0%	18.2%	3.4%	0.0%	0.0%	0.0%	0.0%	0.0%	
Pedestrians	0	0	0	0	0	1	1	0	0	0	0	0	0	0	0	0	0	0	0	0	2	0	0	0	0	0	1	0	
% Pedestrians	0.0%	0.0%	0.0%	0.0%	0.0%	100.0%	100.0%	0.0%	0.0%	0.0%	0.0%	0.0%	0.0%	0.0%	0.0%	0.0%	0.0%	0.0%	0.0%	0.0%	0.0%	0.0%	0.0%	0.0%	0.0%	0.0%	100.0%	0.0%	
Bicycles on Crosswalk	0	0	0	0	0	0	0	0	0	0	0	0	0	0	0	0	0	0	0	0	0	0	0	0	0	0	0	0	
% Bicycles on Crosswalk	0.0%	0.0%	0.0%	0.0%	0.0%	0.0%	0.0%	0.0%	0.0%	0.0%	0.0%	0.0%	0.0%	0.0%	0.0%	0.0%	0.0%	0.0%	0.0%	0.0%	0.0%	0.0%	0.0%	0.0%	0.0%	0.0%	0.0%	0.0%	

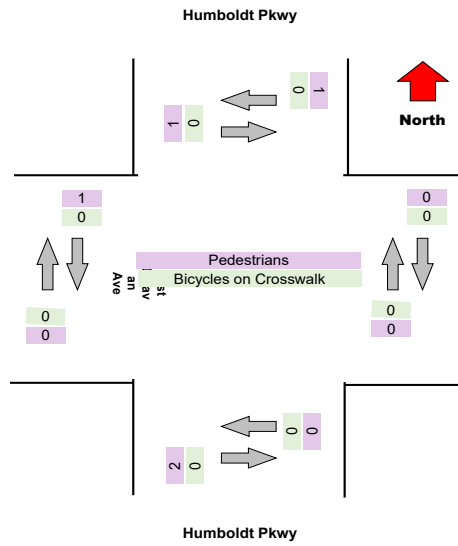
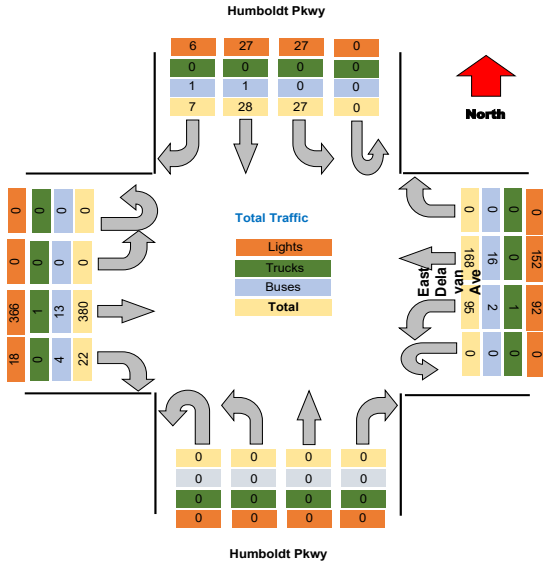

### Turning Movement Peak Hour Data (PM)

4:30:00 PM

Leg Direction	Humboldt Pkwy				East Delavan Ave				Humboldt Pkwy				East Delavan Ave				Total								
	Southbound		Northbound		Westbound		Eastbound		Northbound		Southbound		Eastbound												
Start Time	Right	Thru	Left	U-Turn	App Total	Peds CW	Peds CCW	Right	Thru	Left	U-Turn	App Total	Peds CW	Peds CCW	Right	Thru	Left	U-Turn	App Total	Peds CW	Peds CCW				
4:30:00 PM	3	14	18	0	35	0	0	0	61	25	0	86	0	0	0	1	0	0	1	126	0	0	258		
4:45:00 PM	5	12	11	0	28	0	1	0	62	28	0	90	0	0	0	0	0	0	0	12	95	0	0	225	
5:00:00 PM	5	11	10	0	26	0	0	0	41	30	0	71	0	0	0	0	0	0	0	13	87	0	0	197	
5:15:00 PM	2	7	13	0	22	0	0	0	52	26	0	78	0	0	0	0	0	0	0	16	110	0	0	226	
<b>Grand Total</b>	<b>15</b>	<b>44</b>	<b>52</b>	<b>0</b>	<b>111</b>	<b>0</b>	<b>1</b>	<b>0</b>	<b>216</b>	<b>109</b>	<b>0</b>	<b>325</b>	<b>0</b>	<b>0</b>	<b>0</b>	<b>1</b>	<b>0</b>	<b>0</b>	<b>1</b>	<b>51</b>	<b>419</b>	<b>0</b>	<b>0</b>	<b>906</b>	
% Approach	13.5%	39.6%	46.8%	0.0%	0.0%	0.0%	0.0%	14.2%	85.8%	0.0%	0.0%	0.0%	0.0%	0.0%	45.1%	41.7%	13.2%	0.0%	0.0%	0.0%	66.2%	33.8%	0.0%	0.0%	0.0%
% Total	1.7%	4.9%	5.7%	0.0%	12.3%	0.0%	0.0%	0.0%	23.8%	12.0%	0.0%	35.9%	0.0%	0.0%	0.0%	0.1%	0.0%	0.0%	0.0%	5.6%	46.1%	0.0%	0.0%	51.8%	
PHF	0.750	0.786	0.722	0.000	0.793	0.000	0.000	0.000	0.871	0.908	0.000	0.903	0.000	0.000	0.000	0.250	0.000	0.000	0.250	0.797	0.829	0.000	0.000	0.882	
Lights	10	43	50	0	103	0	0	0	208	108	0	316	0	0	0	0	0	0	0	47	408	0	0	874	
% Lights	66.7%	97.7%	96.2%	0.0%	92.8%	0.0%	0.0%	0.0%	96.3%	99.1%	0.0%	97.2%	0.0%	0.0%	0.0%	0.0%	0.0%	0.0%	0.0%	92.2%	97.6%	0.0%	0.0%	96.5%	
Trucks	0	0	0	0	0	0	0	0	0	0	0	0	0	0	0	0	0	0	0	0	0	0	0	0	
% Trucks	0.0%	0.0%	0.0%	0.0%	0.0%	0.0%	0.0%	0.0%	0.0%	0.0%	0.0%	0.0%	0.0%	0.0%	0.0%	0.0%	0.0%	0.0%	0.0%	0.0%	0.0%	0.0%	0.0%	0.0%	
Buses	5	1	2	0	8	0	0	0	7	1	0	8	0	0	0	0	0	0	0	4	10	0	0	30	
% Buses	33.3%	2.3%	3.8%	0.0%	0.0%	0.0%	0.0%	0.0%	3.2%	0.9%	0.0%	0.0%	0.0%	0.0%	0.0%	0.0%	0.0%	0.0%	0.0%	7.8%	2.4%	0.0%	0.0%	3.3%	
Pedestrians	0	0	0	0	0	0	0	0	0	0	0	0	0	0	2	1	0	0	0	0	0	0	3	1	
% Pedestrians	0.0%	0.0%	0.0%	0.0%	0.0%	0.0%	100.0%	0.0%	0.0%	0.0%	0.0%	0.0%	0.0%	0.0%	0.0%	100.0%	100.0%	0.0%	0.0%	0.0%	0.0%	0.0%	0.0%	100.0%	
Bicycles on Crosswalk	0	0	0	0	0	0	0	0	0	0	0	0	0	0	0	0	0	0	0	0	0	0	0	0	
% Bicycles on Crosswalk	0.0%	0.0%	0.0%	0.0%	0.0%	0.0%	0.0%	0.0%	0.0%	0.0%	0.0%	0.0%	0.0%	0.0%	0.0%	0.0%	0.0%	0.0%	0.0%	0.0%	0.0%	0.0%	0.0%	0.0%	

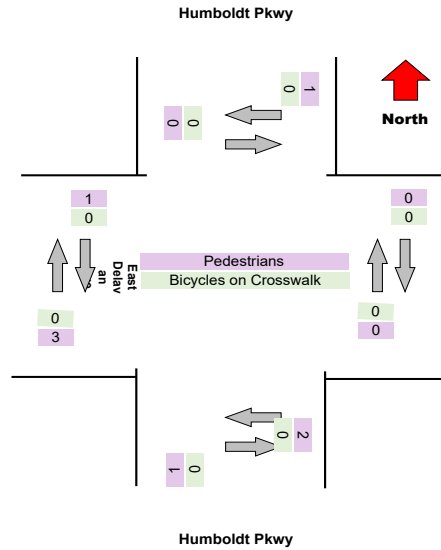
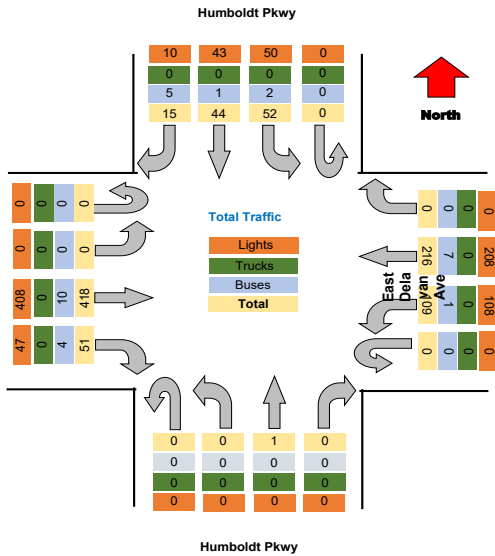



### Turning Movement Data Plot

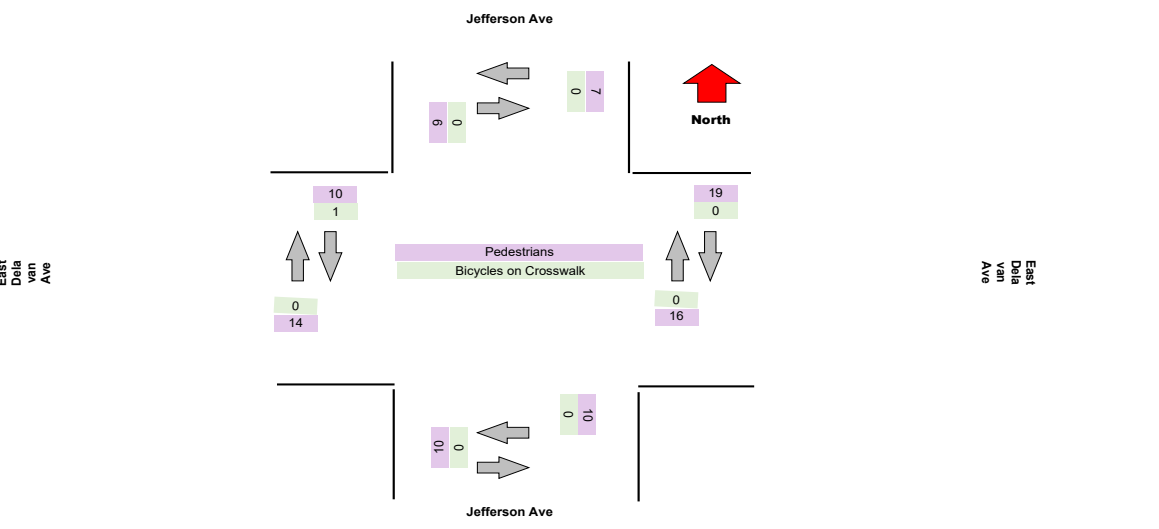
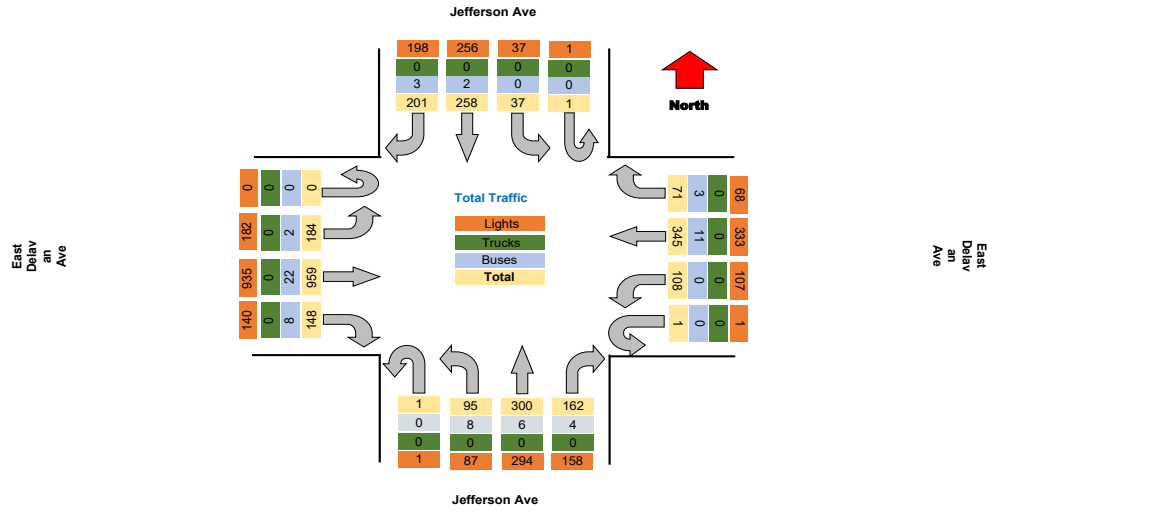

Project : VBH Malta NY  
Site : Site 4  
Location : 42.948550, -73.790036

TSTData.com

Survey Date : 2021-04-28, Wednesday

### Turning Movement Peak Hour Data (AM)

7:30:00 AM

Leg Direction	Jefferson Ave								East Delavan Ave								Jefferson Ave								East Delavan Ave								Total
	Southbound				Westbound				Northbound				Eastbound				Southbound				Westbound				Northbound				Eastbound				
	Right	Thru	Left	U-Turn	App Total	Peds CW	Peds CCW		Right	Thru	Left	U-Turn	App Total	Peds CW	Peds CCW		Right	Thru	Left	U-Turn	App Total	Peds CW	Peds CCW		Right	Thru	Left	U-Turn	App Total	Peds CW	Peds CCW		
7:30:00 AM	6	9	1	0	16	1	0	1	23	5	0	29	0	2	4	15	5	0	26	1	1	3	77	9	0	89	0	0	160				
7:45:00 AM	10	11	1	0	22	0	1	3	11	6	0	21	0	1	4	18	6	0	29	0	0	6	70	9	0	85	0	1	157				
8:00:00 AM	22	13	1	0	36	0	1	3	12	2	0	18	0	1	6	12	5	0	24	0	0	10	56	10	0	76	5	0	154				
8:15:00 AM	24	12	2	0	38	0	0	4	17	6	0	27	0	0	4	11	4	0	19	0	0	9	71	8	0	88	3	2	172				
<b>Grand Total</b>	<b>62</b>	<b>45</b>	<b>5</b>	<b>0</b>	<b>112</b>	<b>1</b>	<b>0</b>	<b>11</b>	<b>63</b>	<b>19</b>	<b>0</b>	<b>95</b>	<b>0</b>	<b>0</b>	<b>18</b>	<b>55</b>	<b>20</b>	<b>0</b>	<b>89</b>	<b>1</b>	<b>1</b>	<b>29</b>	<b>274</b>	<b>36</b>	<b>0</b>	<b>338</b>	<b>3</b>	<b>3</b>	<b>643</b>				
% Approach	55.4%	40.2%	4.5%	0.0%	0.0%	0.0%	0.0%	11.6%	66.3%	20.0%	0.0%	0.0%	0.0%	0.0%	18.4%	57.1%	20.4%	0.0%	0.0%	0.0%	0.0%	8.3%	81.1%	10.7%	0.0%	0.0%	0.0%	0.0%	0.0%				
% Total	9.6%	7.0%	0.8%	0.0%	17.4%	0.0%	0.0%	1.7%	8.8%	3.0%	0.0%	14.8%	0.0%	0.0%	2.8%	8.7%	3.1%	0.0%	15.2%	0.0%	0.0%	4.4%	42.6%	5.6%	0.0%	52.6%	0.0%	0.0%	0.0%				
PHF	0.646	0.865	0.625	0.000	0.737	0.000	0.000	0.688	0.685	0.792	0.000	0.819	0.000	0.000	0.750	0.778	0.833	0.000	0.845	0.000	0.000	0.700	0.890	0.900	0.000	0.949	0.000	0.000	0.935				
Lights	62	45	5	0	112	0	0	10	60	19	0	89	0	0	18	55	18	0	91	0	0	26	268	35	0	329	0	0	621				
% Lights	100.0%	100.0%	100.0%	0.0%	100.0%	0.0%	0.0%	90.9%	95.2%	100.0%	0.0%	93.7%	0.0%	0.0%	100.0%	98.2%	90.0%	0.0%	92.9%	0.0%	0.0%	92.9%	97.8%	97.2%	0.0%	97.3%	0.0%	0.0%	96.6%				
Trucks	0	0	0	0	0	0	0	0	0	0	0	0	0	0	0	0	0	0	0	0	0	0	0	0	0	0	0	0	0				
% Trucks	0.0%	0.0%	0.0%	0.0%	0.0%	0.0%	0.0%	0.0%	0.0%	0.0%	0.0%	0.0%	0.0%	0.0%	0.0%	0.0%	0.0%	0.0%	0.0%	0.0%	0.0%	0.0%	0.0%	0.0%	0.0%	0.0%	0.0%	0.0%	0.0%				
Buses	0	0	0	0	0	0	0	1	3	0	0	4	0	0	0	1	2	0	3	0	0	2	6	1	0	9	0	0	16				
% Buses	0.0%	0.0%	0.0%	0.0%	0.0%	0.0%	0.0%	9.1%	4.8%	0.0%	0.0%	0.0%	0.0%	0.0%	0.0%	1.8%	10.0%	0.0%	0.0%	0.0%	0.0%	7.1%	2.2%	2.8%	0.0%	0.0%	0.0%	0.0%	2.5%				
Pedestrians	0	0	0	0	0	1	2	0	0	0	0	0	4	0	0	0	0	0	1	1	0	0	0	0	0	0	8	3	0				
% Pedestrians	0.0%	0.0%	0.0%	0.0%	0.0%	100.0%	100.0%	0.0%	0.0%	0.0%	0.0%	0.0%	0.0%	100.0%	0.0%	0.0%	0.0%	0.0%	0.0%	100.0%	100.0%	0.0%	0.0%	0.0%	0.0%	0.0%	100.0%	100.0%	0.0%				
Bicycles on Crosswalk	0	0	0	0	0	0	0	0	0	0	0	0	0	0	0	0	0	0	0	0	0	0	0	0	0	0	0	0	0				
% Bicycles on Crosswalk	0.0%	0.0%	0.0%	0.0%	0.0%	0.0%	0.0%	0.0%	0.0%	0.0%	0.0%	0.0%	0.0%	0.0%	0.0%	0.0%	0.0%	0.0%	0.0%	0.0%	0.0%	0.0%	0.0%	0.0%	0.0%	0.0%	0.0%	0.0%	0.0%				

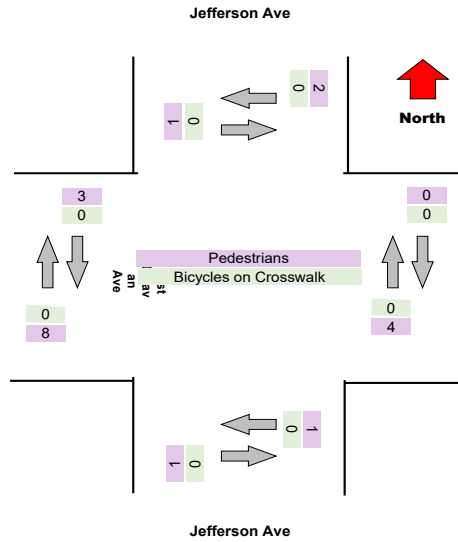
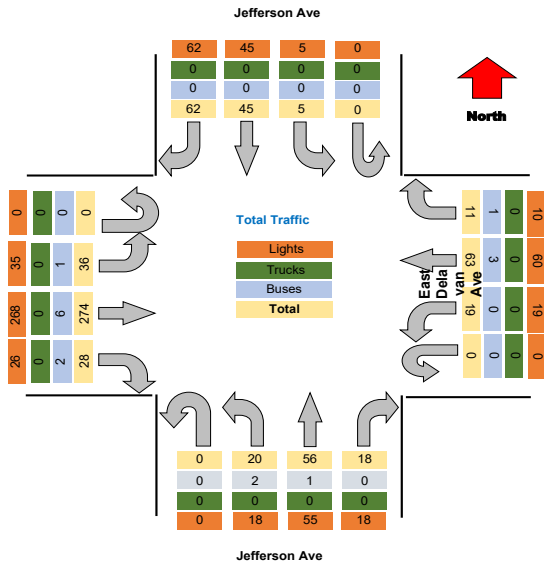

**Turning Movement Peak Hour Data (PM)**

4:30:00 PM

Leg Direction	Jefferson Ave								East Delavan Ave								Jefferson Ave								East Delavan Ave								Total
	Southbound				Northbound				Westbound				Eastbound				Northbound				Eastbound												
	Right	Thru	Left	U-Turn	App Total	Peds CW	Peds CCW		Right	Thru	Left	U-Turn	App Total	Peds CW	Peds CCW		Right	Thru	Left	U-Turn	App Total	Peds CW	Peds CCW		Right	Thru	Left	U-Turn	App Total	Peds CW	Peds CCW		
4:30:00 PM	7	27	3	0	37	2	0	0	4	29	11	0	44	4	3	0	19	20	10	0	49	2	2	0	17	73	17	0	107	1	0	0	237
4:45:00 PM	11	22	4	0	37	1	0	0	6	24	7	0	37	2	2	0	13	25	10	0	48	0	1	0	12	58	15	0	85	0	0	0	207
5:00:00 PM	11	26	5	0	42	0	0	0	8	27	9	0	44	2	0	0	10	32	7	0	49	0	0	0	17	60	21	0	98	2	1	0	233
5:15:00 PM	20	19	3	0	42	0	0	0	5	22	11	0	38	3	3	0	14	24	6	0	44	2	1	0	16	81	14	0	111	0	2	0	235
<b>Grand Total</b>	<b>49</b>	<b>94</b>	<b>15</b>	<b>0</b>	<b>158</b>	<b>3</b>	<b>0</b>	<b>0</b>	<b>23</b>	<b>102</b>	<b>38</b>	<b>0</b>	<b>153</b>	<b>11</b>	<b>6</b>	<b>0</b>	<b>55</b>	<b>101</b>	<b>33</b>	<b>0</b>	<b>190</b>	<b>4</b>	<b>4</b>	<b>0</b>	<b>62</b>	<b>272</b>	<b>67</b>	<b>0</b>	<b>401</b>	<b>3</b>	<b>3</b>	<b>0</b>	<b>912</b>
% Approach	31.0%	59.5%	9.5%	0.0%	0.0%	0.0%	0.0%	0.0%	14.1%	62.6%	23.3%	0.0%	0.0%	0.0%	0.0%	0.0%	25.5%	53.2%	17.4%	0.0%	0.0%	0.0%	0.0%	0.0%	15.5%	67.8%	16.7%	0.0%	0.0%	0.0%	0.0%	0.0%	
% Total	5.4%	10.3%	1.6%	0.0%	17.3%	0.0%	0.0%	0.0%	2.5%	11.2%	4.2%	0.0%	17.9%	0.0%	0.0%	0.0%	6.1%	11.1%	3.6%	0.0%	20.8%	0.0%	0.0%	0.0%	6.8%	29.8%	7.3%	0.0%	44.0%	0.0%	0.0%	0.0%	
PHF	0.613	0.870	0.750	0.000	0.940	0.000	0.000	0.000	0.719	0.879	0.864	0.000	0.926	0.000	0.000	0.000	0.737	0.789	0.825	0.000	0.869	0.000	0.000	0.000	0.912	0.840	0.798	0.000	0.903	0.000	0.000	0.000	0.962
Lights	48	94	15	0	157	0	0	0	23	98	37	0	158	0	0	0	56	99	31	0	186	0	0	0	60	267	67	0	394	0	0	0	895
% Lights	88.0%	100.0%	100.0%	0.0%	99.4%	0.0%	0.0%	0.0%	100.0%	96.1%	97.4%	0.0%	96.9%	0.0%	0.0%	0.0%	100.0%	98.0%	93.9%	0.0%	97.9%	0.0%	0.0%	0.0%	96.8%	98.2%	100.0%	0.0%	98.3%	0.0%	0.0%	0.0%	98.1%
Trucks	0	0	0	0	0	0	0	0	0	0	0	0	0	0	0	0	0	0	0	0	0	0	0	0	0	0	0	0	0	0	0	0	0
% Trucks	0.0%	0.0%	0.0%	0.0%	0.0%	0.0%	0.0%	0.0%	0.0%	0.0%	0.0%	0.0%	0.0%	0.0%	0.0%	0.0%	0.0%	0.0%	0.0%	0.0%	0.0%	0.0%	0.0%	0.0%	0.0%	0.0%	0.0%	0.0%	0.0%	0.0%	0.0%	0.0%	0.0%
Buses	1	0	0	0	1	0	0	0	0	3	0	0	3	0	0	0	0	2	2	0	4	0	0	0	2	3	0	0	5	0	0	0	13
% Buses	2.0%	0.0%	0.0%	0.0%	0.0%	0.0%	0.0%	0.0%	0.0%	2.9%	0.0%	0.0%	0.0%	0.0%	0.0%	0.0%	0.0%	2.0%	6.1%	0.0%	0.0%	0.0%	0.0%	0.0%	3.2%	1.1%	0.0%	0.0%	0.0%	0.0%	0.0%	0.0%	1.4%
Pedestrians	0	0	0	0	3	0	0	0	0	0	0	0	11	6	0	0	0	0	0	0	4	4	0	0	0	0	0	0	8	3	2	0	20
% Pedestrians	0.0%	0.0%	0.0%	0.0%	0.0%	100.0%	0.0%	0.0%	0.0%	0.0%	0.0%	0.0%	0.0%	100.0%	100.0%	0.0%	0.0%	0.0%	0.0%	0.0%	0.0%	100.0%	100.0%	0.0%	0.0%	0.0%	0.0%	0.0%	0.0%	100.0%	66.7%	0.0%	
Bicycles on Crosswalk	0	0	0	0	0	0	0	0	0	0	0	0	0	0	0	0	0	0	0	0	0	0	0	0	0	0	0	0	0	0	1	0	1
% Bicycles on Crosswalk	0.0%	0.0%	0.0%	0.0%	0.0%	0.0%	0.0%	0.0%	0.0%	0.0%	0.0%	0.0%	0.0%	0.0%	0.0%	0.0%	0.0%	0.0%	0.0%	0.0%	0.0%	0.0%	0.0%	0.0%	0.0%	0.0%	0.0%	0.0%	0.0%	0.0%	33.3%	0.0%	

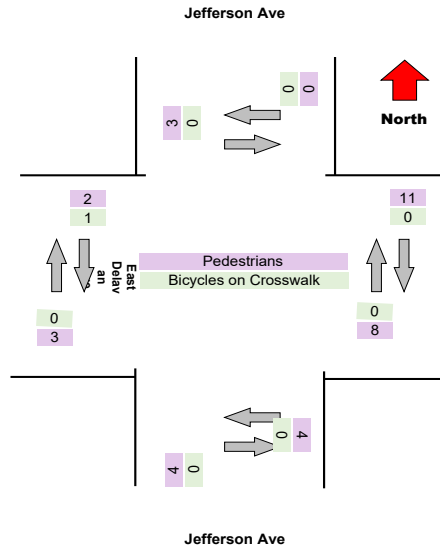
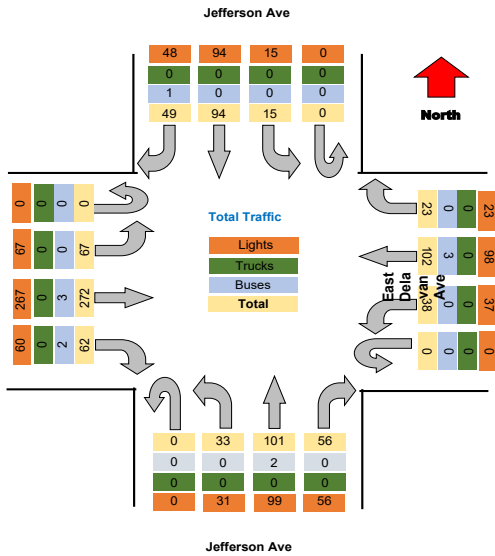



### Turning Movement Data Plot

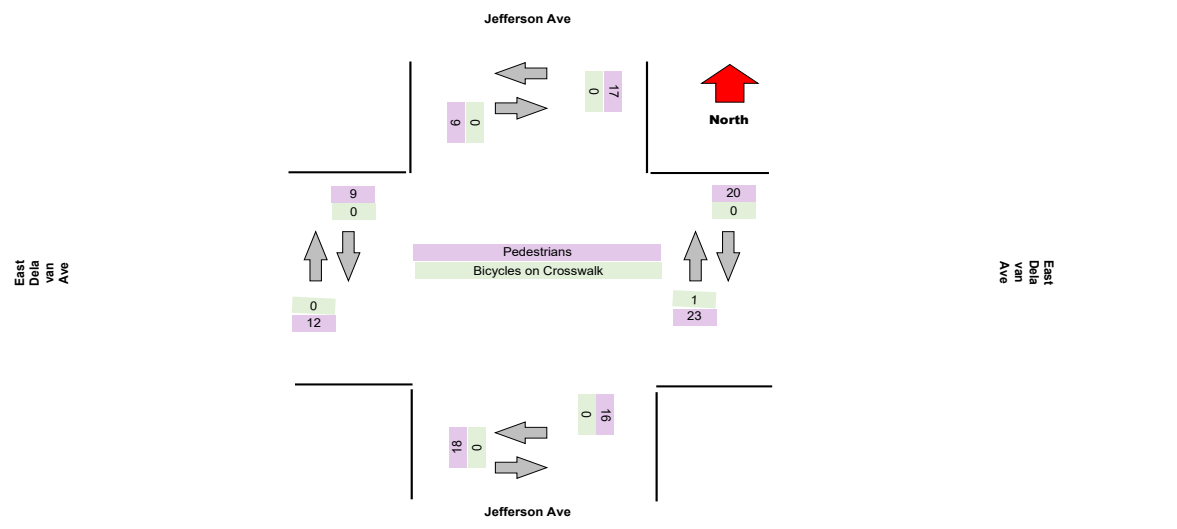
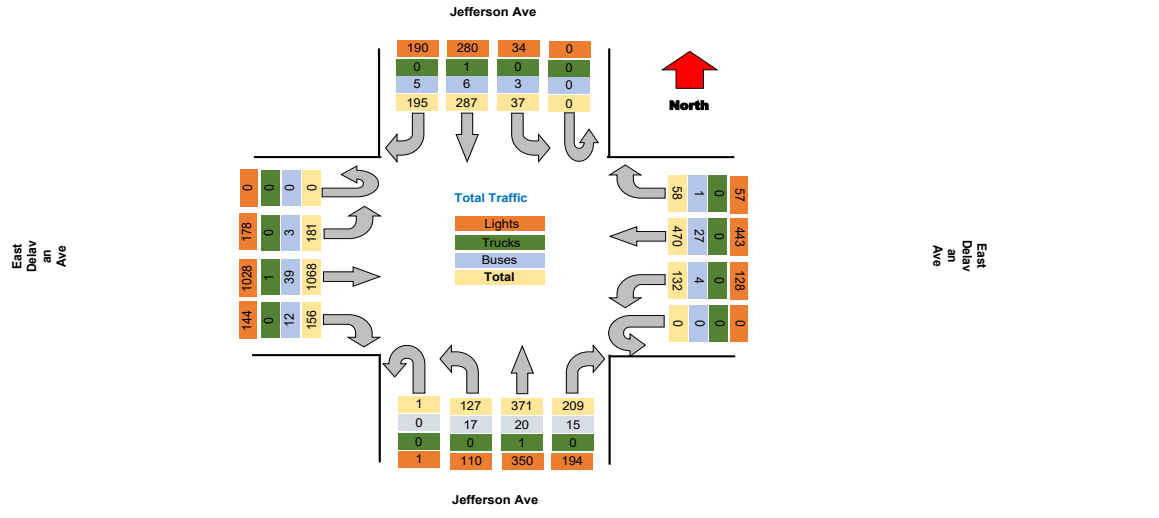



Project : VBH Malta NY  
Site : Site 4  
Location : 42.948550, -73.790036  
Survey Date : 2021-04-28, Wednesday

TSTData.com

**Turning Movement Peak Hour Data (AM)**

7:30:00 AM

Leg Direction	Jefferson Ave					East Delavan Ave					Jefferson Ave					East Delavan Ave					Total								
	Right	Thru	Left	U-Turn	App Total	Right	Thru	Left	U-Turn	App Total	Right	Thru	Left	U-Turn	App Total	Right	Thru	Left	U-Turn	App Total									
7:30:00 AM	12	15	1	0	28	0	0	0	0	0	1	24	3	0	28	8	22	4	0	36	4	97	2	0	103	0	0	195	
7:45:00 AM	17	30	1	0	48	0	4	0	0	4	3	47	9	0	63	18	17	7	0	43	1	5	63	10	0	78	0	1	232
8:00:00 AM	22	12	2	0	36	0	0	0	0	0	6	23	6	0	35	8	24	8	0	41	0	13	86	6	0	105	0	1	217
8:15:00 AM	23	10	1	0	34	1	5	0	0	6	4	36	7	0	52	13	21	7	0	41	0	5	81	16	0	92	0	0	209
<b>Grand Total</b>	<b>74</b>	<b>67</b>	<b>5</b>	<b>0</b>	<b>146</b>	<b>1</b>	<b>9</b>	<b>0</b>	<b>0</b>	<b>14</b>	<b>130</b>	<b>25</b>	<b>0</b>	<b>178</b>	<b>47</b>	<b>84</b>	<b>26</b>	<b>0</b>	<b>151</b>	<b>1</b>	<b>27</b>	<b>307</b>	<b>34</b>	<b>0</b>	<b>368</b>	<b>0</b>	<b>2</b>	<b>853</b>	
% Approach	50.7%	45.9%	3.4%	0.0%	0.0%	7.9%	73.0%	14.0%	0.0%	0.0%	29.2%	52.2%	16.1%	0.0%	0.0%	7.3%	83.4%	9.2%	0.0%	0.0%	0.0%	0.0%	0.0%	0.0%	0.0%	0.0%	0.0%	0.0%	0.0%
% Total	8.7%	7.9%	0.6%	0.0%	17.1%	1.6%	15.2%	2.9%	0.0%	20.9%	5.5%	9.8%	3.0%	0.0%	18.9%	3.2%	36.0%	4.0%	0.0%	43.1%	0.0%	0.0%	0.0%	0.0%	0.0%	0.0%	0.0%	0.0%	0.0%
PHF	0.804	0.558	0.625	0.000	0.760	0.583	0.691	0.694	0.000	0.706	0.653	0.875	0.813	0.000	0.936	0.519	0.791	0.531	0.000	0.876	0.000	0.000	0.000	0.000	0.000	0.000	0.000	0.919	
Lights	72	67	5	0	144	14	120	24	0	158	43	79	19	0	141	23	300	34	0	357	0	0	0	0	0	0	0	800	
% Lights	87.3%	100.0%	100.0%	0.0%	98.6%	100.0%	92.3%	96.0%	0.0%	88.8%	81.5%	94.0%	73.1%	0.0%	87.6%	85.2%	97.7%	100.0%	0.0%	97.0%	0.0%	0.0%	0.0%	0.0%	0.0%	0.0%	0.0%	93.8%	
Trucks	0	0	0	0	0	0	0	0	0	0	0	0	0	0	0	0	0	0	0	0	0	0	0	0	0	0	0	0	
% Trucks	0.0%	0.0%	0.0%	0.0%	0.0%	0.0%	0.0%	0.0%	0.0%	0.0%	0.0%	0.0%	0.0%	0.0%	0.0%	0.0%	0.0%	0.0%	0.0%	0.0%	0.0%	0.0%	0.0%	0.0%	0.0%	0.0%	0.0%	0.0%	
Buses	2	0	0	0	2	0	10	1	0	11	4	5	7	0	16	4	7	0	0	11	0	0	0	0	0	0	0	40	
% Buses	2.7%	0.0%	0.0%	0.0%	0.0%	0.0%	7.7%	4.0%	0.0%	0.0%	8.5%	6.0%	26.9%	0.0%	0.0%	14.8%	2.3%	0.0%	0.0%	0.0%	0.0%	0.0%	0.0%	0.0%	0.0%	0.0%	4.7%		
Pedestrians	0	0	0	0	0	0	0	0	0	0	0	0	0	0	0	0	0	0	0	0	0	0	0	0	0	0	0	0	
% Pedestrians	0.0%	0.0%	0.0%	0.0%	0.0%	0.0%	0.0%	0.0%	0.0%	0.0%	0.0%	0.0%	0.0%	0.0%	0.0%	0.0%	0.0%	0.0%	0.0%	0.0%	0.0%	0.0%	0.0%	0.0%	0.0%	0.0%	0.0%	0.0%	
Bicycles on Crosswalk	0	0	0	0	0	0	0	0	0	0	0	0	0	0	0	0	0	0	0	0	0	0	0	0	0	0	0	0	
% Bicycles on Crosswalk	0.0%	0.0%	0.0%	0.0%	0.0%	0.0%	0.0%	0.0%	0.0%	0.0%	0.0%	0.0%	0.0%	0.0%	0.0%	0.0%	0.0%	0.0%	0.0%	0.0%	0.0%	0.0%	0.0%	0.0%	0.0%	0.0%	0.0%	0.0%	

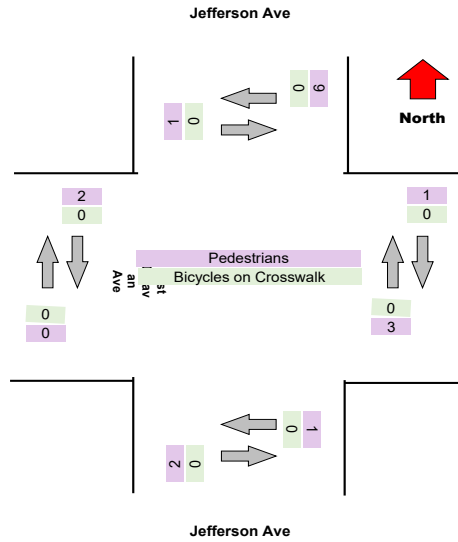
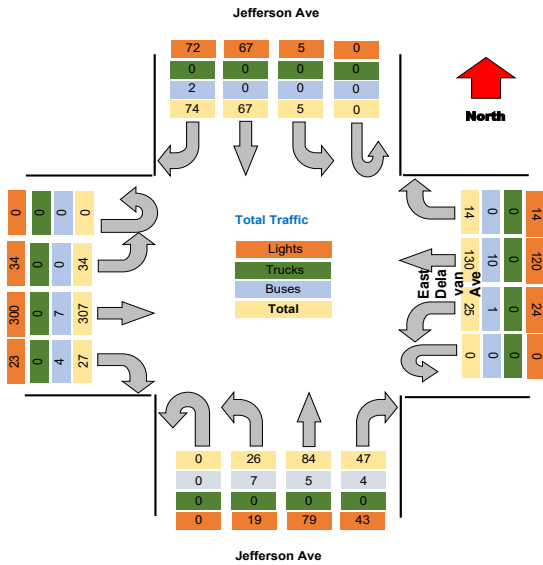

**Turning Movement Peak Hour Data (PM)**

4:30:00 PM

Leg Direction	Jefferson Ave					East Delavan Ave					Jefferson Ave					East Delavan Ave					Total									
	Southbound					Westbound					Northbound					Eastbound														
Start Time	Right	Thru	Left	U-Turn	App Total	Peds CW	Peds CCW	Right	Thru	Left	U-Turn	App Total	Peds CW	Peds CCW	Right	Thru	Left	U-Turn	App Total	Peds CW	Peds CCW	Total								
4:30:00 PM	13	27	3	0	43	0	1	2	35	15	0	52	2	1	14	27	13	0	54	1	3	17	85	22	0	124	8	1	273	
4:45:00 PM	9	17	5	0	31	0	0	7	40	11	0	58	0	3	14	31	11	0	56	2	1	9	65	10	0	84	2	0	229	
5:00:00 PM	5	26	3	0	34	1	0	10	24	10	0	44	0	2	21	43	9	0	73	0	1	12	76	29	0	117	1	1	268	
5:15:00 PM	11	25	0	0	36	0	0	2	29	13	0	44	1	2	14	29	8	1	53	1	0	9	67	17	0	93	0	1	226	
<b>Grand Total</b>	<b>38</b>	<b>85</b>	<b>11</b>	<b>0</b>	<b>144</b>	<b>1</b>	<b>0</b>	<b>21</b>	<b>128</b>	<b>49</b>	<b>0</b>	<b>198</b>	<b>3</b>	<b>6</b>	<b>63</b>	<b>130</b>	<b>42</b>	<b>1</b>	<b>236</b>	<b>4</b>	<b>5</b>	<b>47</b>	<b>293</b>	<b>78</b>	<b>0</b>	<b>418</b>	<b>11</b>	<b>3</b>	<b>996</b>	
% Approach	26.4%	66.0%	7.6%	0.0%	0.0%	0.0%	0.0%	10.6%	64.6%	24.7%	0.0%	0.0%	0.0%	0.0%	26.7%	55.1%	17.8%	0.4%	0.0%	0.0%	0.0%	11.2%	70.1%	18.7%	0.0%	0.0%	0.0%	0.0%	0.0%	
% Total	3.8%	9.5%	1.1%	0.0%	14.5%	0.0%	0.0%	2.1%	12.9%	4.9%	0.0%	19.9%	0.0%	0.0%	6.3%	13.1%	4.2%	0.1%	23.7%	0.0%	0.0%	4.7%	29.4%	7.8%	0.0%	42.0%	0.0%	0.0%	0.0%	
PHF	0.731	0.880	0.550	0.000	0.837	0.000	0.000	0.525	0.800	0.817	0.000	0.853	0.000	0.000	0.750	0.756	0.808	0.250	0.808	0.000	0.000	0.691	0.862	0.672	0.000	0.843	0.000	0.000	0.912	
Lights	37	92	11	0	140	0	0	21	122	49	0	192	0	0	59	125	39	1	224	0	0	45	285	77	0	407	0	0	963	
% Lights	97.4%	96.8%	100.0%	0.0%	97.2%	0.0%	0.0%	100.0%	95.3%	100.0%	0.0%	97.0%	0.0%	0.0%	93.7%	96.2%	92.9%	100.0%	94.9%	0.0%	0.0%	95.7%	97.3%	98.7%	0.0%	97.4%	0.0%	0.0%	96.7%	
Trucks	0	0	0	0	0	0	0	0	0	0	0	0	0	0	0	1	0	0	1	0	0	0	0	0	0	0	0	0	1	
% Trucks	0.0%	0.0%	0.0%	0.0%	0.0%	0.0%	0.0%	0.0%	0.0%	0.0%	0.0%	0.0%	0.0%	0.0%	0.0%	0.8%	0.0%	0.0%	0.4%	0.0%	0.0%	0.0%	0.0%	0.0%	0.0%	0.0%	0.0%	0.0%	0.1%	
Buses	1	3	0	0	4	0	0	0	6	0	0	6	0	0	4	4	3	0	11	0	0	2	8	1	0	11	0	0	32	
% Buses	2.6%	3.2%	0.0%	0.0%	0.0%	0.0%	0.0%	0.0%	4.7%	0.0%	0.0%	0.0%	0.0%	0.0%	6.3%	3.1%	7.1%	0.0%	0.0%	0.0%	0.0%	4.3%	2.7%	1.3%	0.0%	0.0%	0.0%	0.0%	3.2%	
Pedestrians	0	0	0	0	0	1	3	0	0	0	0	3	6	0	0	0	0	0	4	5	0	0	0	0	0	0	0	11	3	0
% Pedestrians	0.0%	0.0%	0.0%	0.0%	0.0%	100.0%	100.0%	0.0%	0.0%	0.0%	0.0%	0.0%	100.0%	100.0%	0.0%	0.0%	0.0%	0.0%	0.0%	0.0%	100.0%	100.0%	0.0%	0.0%	0.0%	0.0%	0.0%	0.0%	100.0%	0.0%
Bicycles on Crosswalk	0	0	0	0	0	0	0	0	0	0	0	0	0	0	0	0	0	0	0	0	0	0	0	0	0	0	0	0	0	
% Bicycles on Crosswalk	0.0%	0.0%	0.0%	0.0%	0.0%	0.0%	0.0%	0.0%	0.0%	0.0%	0.0%	0.0%	0.0%	0.0%	0.0%	0.0%	0.0%	0.0%	0.0%	0.0%	0.0%	0.0%	0.0%	0.0%	0.0%	0.0%	0.0%	0.0%	0.0%	

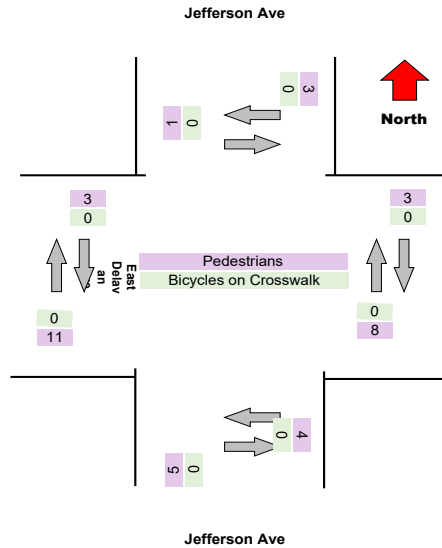
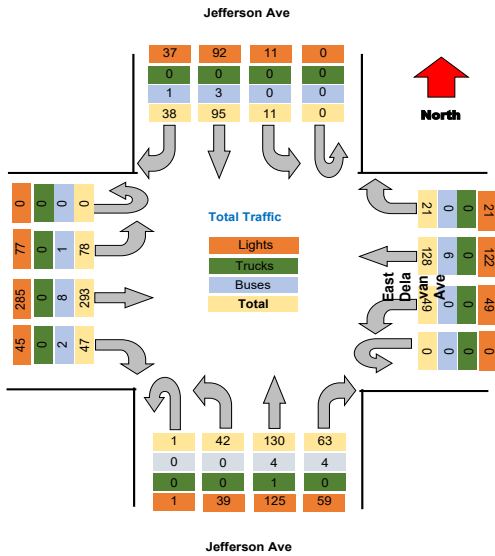

Project	LaBella
Project Code	LaBella
Site Name	29
Legs and Movements	All Processed Legs & Move
Bin Size	15 minutes
Survey Date	2021-11-04, Thursday
Location	29
Latitude and Longitude	42.922152, -78.854005

	Start	End	PHF
Forced Peak AM	2021/11/04 07:30:00	2021/11/04 08:30:00	0.9
Forced Peak PM	2021/11/04 16:30:00	2021/11/04 17:30:00	0.93
AM Peak	2021/11/04 07:30:00	2021/11/04 08:30:00	0.9
PM Peak	2021/11/04 16:30:00	2021/11/04 17:30:00	0.93

### Turning Movement Data

Leg Direction	Jefferson Ave										East Delavan Ave										Total
	Southbound					Westbound					Northbound					Eastbound					
	Right	Thru	Left	U-Turn	App Total	Right	Thru	Left	U-Turn	App Total	Right	Thru	Left	U-Turn	App Total	Right	Thru	Left	U-Turn	App Total	
Start Time																					
6:30:00 AM	17	4	1	0	22	1	10	4	0	15	5	10	3	0	18	1	36	2	0	41	96
6:45:00 AM	8	8	1	0	17	3	18	1	0	22	5	11	2	0	21	2	52	1	0	55	115
Hourly Total	25	12	2	0	39	4	28	5	0	37	10	21	5	0	39	5	88	3	0	96	211
7:00:00 AM	10	8	2	0	18	2	12	1	0	16	9	8	5	0	21	1	59	3	0	63	118
7:15:00 AM	23	11	0	0	34	7	16	5	0	28	7	14	10	0	40	3	42	2	0	47	149
7:30:00 AM	9	16	3	0	28	1	22	4	0	27	9	14	6	0	29	9	30	3	0	102	186
7:45:00 AM	16	15	3	0	34	6	40	6	0	54	12	22	7	0	41	10	77	11	0	98	227
Hourly Total	58	48	8	0	114	16	90	16	0	125	37	56	28	0	131	23	268	19	0	310	680
8:00:00 AM	13	19	4	0	36	8	26	10	0	45	10	21	9	0	41	14	68	9	0	91	213
8:15:00 AM	21	18	0	0	39	3	28	6	0	37	16	19	6	0	43	6	56	6	0	68	187
Hourly Total	34	37	4	0	75	11	54	16	0	82	26	40	15	0	84	20	124	15	0	159	400
4:00:00 PM	9	30	8	0	47	7	54	9	0	70	20	35	9	0	64	19	67	20	0	106	287
4:15:00 PM	9	26	6	0	41	4	29	9	0	42	14	32	8	0	54	19	79	15	0	113	250
4:30:00 PM	7	29	2	0	38	7	34	7	0	48	20	34	6	0	60	20	76	16	0	112	258
4:45:00 PM	6	19	4	0	29	6	32	10	0	48	15	28	4	0	47	16	53	21	0	90	214
Hourly Total	31	104	20	0	155	24	149	35	0	208	69	129	27	0	225	74	275	72	0	421	1009
5:00:00 PM	10	29	5	0	44	5	34	10	0	49	15	32	13	0	60	17	68	21	0	106	259
5:15:00 PM	8	27	5	0	40	9	31	11	0	51	13	27	12	0	52	10	62	17	0	89	232
5:30:00 PM	17	17	11	0	45	8	35	8	0	51	15	28	15	0	58	22	65	14	0	101	265
5:45:00 PM	41	22	8	0	71	3	36	8	0	47	8	22	8	0	38	11	51	15	0	77	233
Hourly Total	76	95	29	0	200	25	136	37	0	198	51	109	48	0	208	60	246	67	0	373	979
Grand Total	224	296	63	0	583	80	457	109	0	650	193	355	123	0	667	182	1001	176	0	1359	3279
% Approach	38.4%	50.8%	10.8%	0.0%	0.0%	12.3%	70.3%	16.8%	0.0%	0.0%	28.1%	51.7%	17.9%	0.0%	0.0%	13.4%	73.7%	13.0%	0.0%	0.0%	0.0%
% Total	6.8%	8.0%	1.9%	0.0%	17.8%	2.4%	13.9%	3.3%	0.0%	19.8%	5.9%	10.8%	3.8%	0.0%	21.0%	5.6%	30.5%	5.4%	0.0%	41.4%	0.0%
Lights	220	290	59	0	569	79	424	108	0	611	177	336	111	0	624	170	961	174	0	1305	3109
% Lights	98.2%	98.0%	93.7%	0.0%	97.8%	98.8%	92.8%	99.1%	0.0%	94.0%	91.7%	94.6%	90.2%	0.0%	90.8%	93.4%	96.0%	96.9%	0.0%	96.0%	94.8%
Trucks	0	0	0	0	0	0	1	0	0	1	0	2	0	0	2	0	2	0	0	2	5
% Trucks	0.0%	0.0%	0.0%	0.0%	0.0%	0.0%	0.2%	0.0%	0.0%	0.2%	0.0%	0.6%	0.0%	0.0%	0.3%	0.0%	0.2%	0.0%	0.0%	0.1%	0.2%
Buses	4	6	4	0	14	1	32	1	0	34	16	17	12	0	45	12	38	2	0	52	146
% Buses	1.8%	2.0%	6.3%	0.0%	0.0%	0.0%	7.0%	0.9%	0.0%	0.0%	8.3%	4.5%	9.8%	0.0%	0.0%	6.6%	3.8%	1.1%	0.0%	0.0%	4.4%
Pedestrians	0	0	0	0	0	0	0	0	0	0	0	0	0	0	0	0	0	0	0	0	14
% Pedestrians	0.0%	0.0%	0.0%	0.0%	0.0%	0.0%	0.0%	0.0%	0.0%	0.0%	0.0%	0.0%	0.0%	0.0%	0.0%	0.0%	0.0%	0.0%	0.0%	0.0%	100.0%
Bicycles on Crosswalk	0	0	0	0	0	0	0	0	0	0	0	0	0	0	0	0	0	0	0	0	0
% Bicycles on Crosswalk	0.0%	0.0%	0.0%	0.0%	0.0%	0.0%	0.0%	0.0%	0.0%	0.0%	0.0%	0.0%	0.0%	0.0%	0.0%	0.0%	0.0%	0.0%	0.0%	0.0%	0.0%

Project : VBH Malta NY  
 Site : Site 4  
 Location : 42.948550, -73.790036  
 Survey Date : 2021-04-28, Wednesday

### Turning Movement Data Plot

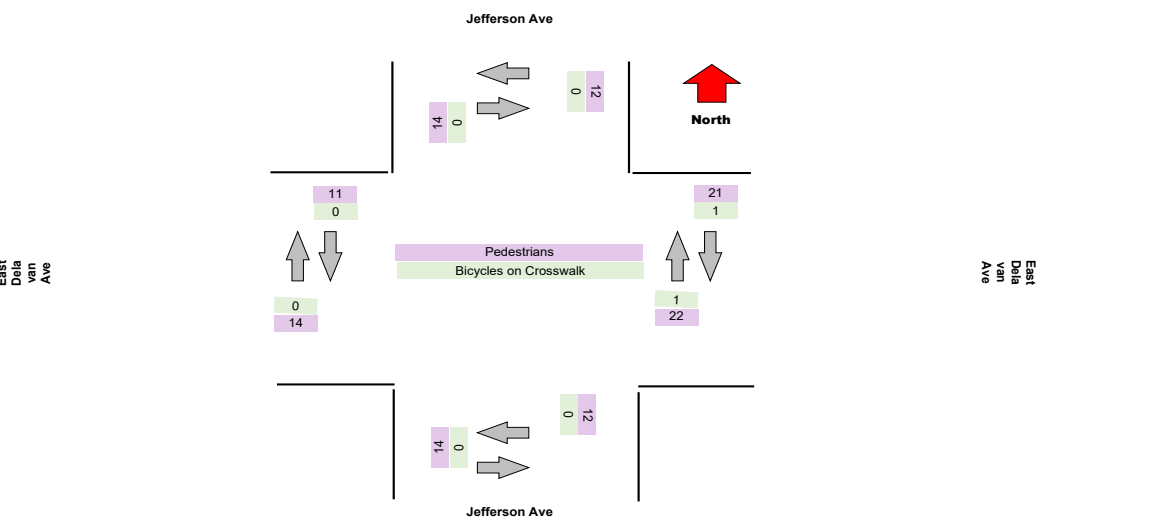
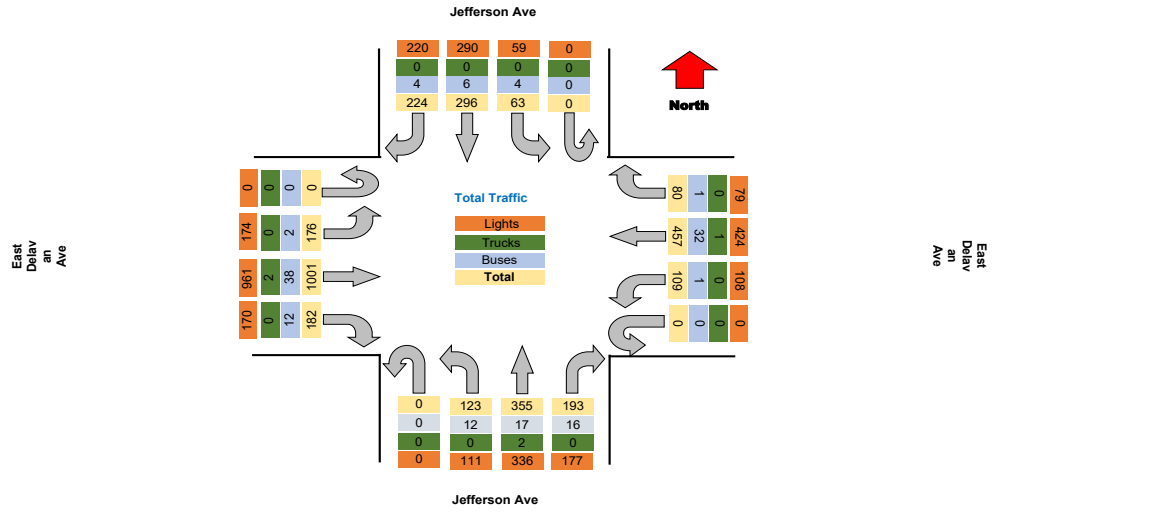

Project : VBH Malta NY  
 Site : Site 4  
 Location : 42.948550, -73.790036  
 Survey Date : 2021-04-28, Wednesday

TSTData.com

**Turning Movement Peak Hour Data (AM)**

7:30:00 AM

Leg Direction	Jefferson Ave					East Delavan Ave					Jefferson Ave					East Delavan Ave					Total									
	Southbound		Westbound			Northbound		Eastbound			Southbound		Westbound			Northbound		Eastbound												
Start Time	Right	Thru	Left	U-Turn	App Total	Peds CW	Peds CCW	Right	Thru	Left	U-Turn	App Total	Peds CW	Peds CCW	Right	Thru	Left	U-Turn	App Total	Peds CW	Peds CCW									
7:30:00 AM	9	16	3	0	28	0	0	1	22	4	0	27	0	0	9	14	6	0	29	2	0	102	1	0	186					
7:45:00 AM	16	15	3	0	34	1	2	6	40	6	0	54	0	0	12	22	7	0	41	0	1	10	77	11	0	98	2	0	227	
8:00:00 AM	13	19	4	0	36	0	1	8	26	10	0	44	0	1	10	21	9	0	41	0	1	14	68	9	0	91	1	1	213	
8:15:00 AM	21	16	0	0	39	0	0	3	29	6	0	37	0	2	16	19	6	0	43	0	0	6	56	6	0	68	3	2	187	
<b>Grand Total</b>	<b>59</b>	<b>68</b>	<b>10</b>	<b>0</b>	<b>127</b>	<b>1</b>	<b>3</b>	<b>18</b>	<b>116</b>	<b>26</b>	<b>0</b>	<b>153</b>	<b>0</b>	<b>3</b>	<b>47</b>	<b>76</b>	<b>28</b>	<b>0</b>	<b>154</b>	<b>2</b>	<b>2</b>	<b>39</b>	<b>291</b>	<b>29</b>	<b>0</b>	<b>359</b>	<b>7</b>	<b>3</b>	<b>813</b>	
<b>% Approach</b>	43.1%	49.6%	7.3%	0.0%	0.0%	0.0%	0.0%	11.0%	71.2%	16.0%	0.0%	0.0%	0.0%	0.0%	30.5%	49.4%	19.2%	0.0%	0.0%	0.0%	0.0%	10.9%	81.1%	8.1%	0.0%	0.0%	0.0%	0.0%	0.0%	
<b>% Total</b>	7.3%	8.4%	1.2%	0.0%	16.9%	0.0%	0.0%	2.2%	14.3%	3.2%	0.0%	20.0%	0.0%	0.0%	5.8%	9.3%	3.4%	0.0%	18.9%	0.0%	0.0%	4.8%	35.8%	3.6%	0.0%	44.2%	0.0%	0.0%	0.0%	
<b>PHF</b>	0.702	0.895	0.625	0.000	0.878	0.000	0.000	0.563	0.725	0.650	0.000	0.755	0.000	0.000	0.734	0.864	0.778	0.000	0.895	0.000	0.000	0.696	0.808	0.659	0.000	0.880	0.000	0.000	0.895	
<b>Lights</b>	57	68	9	0	134	0	0	18	104	26	0	148	0	0	40	70	24	0	134	0	0	35	284	29	0	348	0	0	764	
<b>% Lights</b>	96.6%	100.0%	90.0%	0.0%	97.8%	0.0%	0.0%	100.0%	89.7%	100.0%	0.0%	90.8%	0.0%	0.0%	85.1%	92.1%	85.7%	0.0%	87.0%	0.0%	0.0%	89.7%	97.6%	100.0%	0.0%	96.9%	0.0%	0.0%	94.0%	
<b>Trucks</b>	0	0	0	0	0	0	0	0	0	0	0	0	0	0	0	1	0	0	1	0	0	0	1	0	0	1	0	0	2	
<b>% Trucks</b>	0.0%	0.0%	0.0%	0.0%	0.0%	0.0%	0.0%	0.0%	0.0%	0.0%	0.0%	0.0%	0.0%	0.0%	0.0%	1.3%	0.0%	0.0%	0.6%	0.0%	0.0%	0.0%	0.3%	0.0%	0.0%	0.3%	0.0%	0.0%	0.2%	
<b>Buses</b>	2	0	1	0	3	0	0	0	12	0	0	12	0	0	7	5	4	0	16	0	0	4	6	0	0	10	0	0	41	
<b>% Buses</b>	3.4%	0.0%	10.0%	0.0%	0.0%	0.0%	0.0%	0.0%	10.3%	0.0%	0.0%	0.0%	0.0%	0.0%	14.9%	6.8%	14.3%	0.0%	0.0%	0.0%	0.0%	10.3%	2.1%	0.0%	0.0%	0.0%	0.0%	0.0%	5.0%	
<b>Pedestrians</b>	0	0	0	0	0	1	3	0	0	0	0	0	3	0	0	0	0	0	0	2	2	0	0	0	0	0	7	3	0	
<b>% Pedestrians</b>	0.0%	0.0%	0.0%	0.0%	0.0%	100.0%	100.0%	0.0%	0.0%	0.0%	0.0%	0.0%	0.0%	0.0%	0.0%	0.0%	0.0%	0.0%	0.0%	0.0%	100.0%	100.0%	0.0%	0.0%	0.0%	0.0%	0.0%	100.0%	100.0%	0.0%
<b>Bicycles on Crosswalk</b>	0	0	0	0	0	0	0	0	0	0	0	0	0	0	0	0	0	0	0	0	0	0	0	0	0	0	0	0	0	
<b>% Bicycles on Crosswalk</b>	0.0%	0.0%	0.0%	0.0%	0.0%	0.0%	0.0%	0.0%	0.0%	0.0%	0.0%	0.0%	0.0%	0.0%	0.0%	0.0%	0.0%	0.0%	0.0%	0.0%	0.0%	0.0%	0.0%	0.0%	0.0%	0.0%	0.0%	0.0%	0.0%	

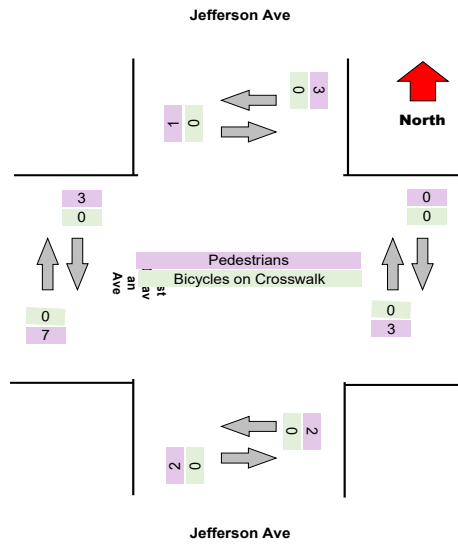
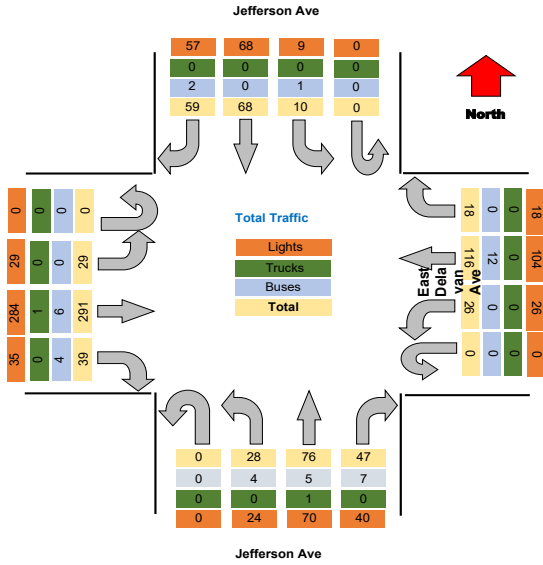

**Turning Movement Peak Hour Data (PM)**

4:30:00 PM

Leg Direction	Jefferson Ave				East Delavan Ave				Jefferson Ave				East Delavan Ave				Total												
	Southbound				Westbound				Northbound				Eastbound																
	Right	Thru	Left	U-Turn	App Total	Peds CW	Peds CCW	Right	Thru	Left	U-Turn	App Total	Peds CW	Peds CCW	Right	Thru		Left	U-Turn	App Total	Peds CW	Peds CCW							
4:30:00 PM	7	29	2	0	38	1	4	7	34	7	0	48	0	1	20	34	6	0	60	0	1	20	76	16	0	112	4	1	258
4:45:00 PM	6	19	4	0	29	1	0	6	32	10	0	48	2	1	15	28	4	0	47	1	0	16	53	21	0	90	0	2	214
5:00:00 PM	10	29	5	0	44	4	3	5	34	10	0	49	4	1	15	32	13	0	60	2	2	17	68	21	0	106	0	1	259
5:15:00 PM	8	27	5	0	40	1	0	9	31	11	0	51	1	4	13	27	12	0	52	1	2	10	62	17	0	89	2	2	232
<b>Grand Total</b>	<b>31</b>	<b>104</b>	<b>16</b>	<b>0</b>	<b>151</b>	<b>7</b>	<b>7</b>	<b>27</b>	<b>131</b>	<b>38</b>	<b>0</b>	<b>196</b>	<b>7</b>	<b>7</b>	<b>63</b>	<b>121</b>	<b>35</b>	<b>0</b>	<b>219</b>	<b>4</b>	<b>5</b>	<b>63</b>	<b>259</b>	<b>75</b>	<b>0</b>	<b>397</b>	<b>3</b>	<b>6</b>	<b>963</b>
% Approach	20.5%	68.9%	10.6%	0.0%	0.0%	0.0%	0.0%	13.8%	66.8%	19.4%	0.0%	0.0%	0.0%	0.0%	28.6%	55.3%	16.0%	0.0%	0.0%	0.0%	0.0%	15.9%	65.2%	18.9%	0.0%	0.0%	0.0%	0.0%	0.0%
% Total	3.2%	10.8%	1.7%	0.0%	15.7%	0.0%	0.0%	2.8%	13.6%	3.9%	0.0%	20.4%	0.0%	0.0%	6.5%	12.6%	3.6%	0.0%	22.7%	0.0%	0.0%	6.5%	26.9%	7.8%	0.0%	41.2%	0.0%	0.0%	0.0%
PHF	0.775	0.897	0.800	0.000	0.858	0.000	0.000	0.750	0.963	0.864	0.000	0.961	0.000	0.000	0.788	0.890	0.673	0.000	0.913	0.000	0.000	0.788	0.852	0.893	0.000	0.886	0.000	0.000	0.930
Lights	31	101	16	0	148	0	0	27	124	38	0	189	0	0	60	118	33	0	211	0	0	61	252	74	0	387	0	0	935
% Lights	100.0%	97.1%	100.0%	0.0%	98.0%	0.0%	0.0%	100.0%	94.7%	100.0%	0.0%	96.4%	0.0%	0.0%	85.2%	97.5%	94.3%	0.0%	96.3%	0.0%	0.0%	96.8%	97.3%	98.7%	0.0%	97.5%	0.0%	0.0%	97.1%
Trucks	0	0	0	0	0	0	0	0	0	0	0	0	0	0	0	0	0	0	0	0	0	0	0	0	0	0	0	0	0
% Trucks	0.0%	0.0%	0.0%	0.0%	0.0%	0.0%	0.0%	0.0%	0.0%	0.0%	0.0%	0.0%	0.0%	0.0%	0.0%	0.0%	0.0%	0.0%	0.0%	0.0%	0.0%	0.0%	0.0%	0.0%	0.0%	0.0%	0.0%	0.0%	0.0%
Buses	0	3	0	0	3	0	0	0	7	0	0	7	0	0	3	3	2	0	8	0	0	2	7	1	0	10	0	0	28
% Buses	0.0%	2.9%	0.0%	0.0%	0.0%	0.0%	0.0%	0.0%	5.3%	0.0%	0.0%	0.0%	0.0%	0.0%	4.8%	2.5%	5.7%	0.0%	0.0%	0.0%	0.0%	3.2%	2.7%	1.3%	0.0%	0.0%	0.0%	0.0%	2.9%
Pedestrians	0	0	0	0	0	7	7	0	0	0	0	0	7	7	0	0	0	0	0	4	5	0	0	0	0	0	6	6	0
% Pedestrians	0.0%	0.0%	0.0%	0.0%	0.0%	100.0%	100.0%	0.0%	0.0%	0.0%	0.0%	0.0%	100.0%	100.0%	0.0%	0.0%	0.0%	0.0%	0.0%	0.0%	100.0%	100.0%	0.0%	0.0%	0.0%	0.0%	0.0%	0.0%	0.0%
Bicycles on Crosswalk	0	0	0	0	0	0	0	0	0	0	0	0	0	0	0	0	0	0	0	0	0	0	0	0	0	0	0	0	0
% Bicycles on Crosswalk	0.0%	0.0%	0.0%	0.0%	0.0%	0.0%	0.0%	0.0%	0.0%	0.0%	0.0%	0.0%	0.0%	0.0%	0.0%	0.0%	0.0%	0.0%	0.0%	0.0%	0.0%	0.0%	0.0%	0.0%	0.0%	0.0%	0.0%	0.0%	0.0%

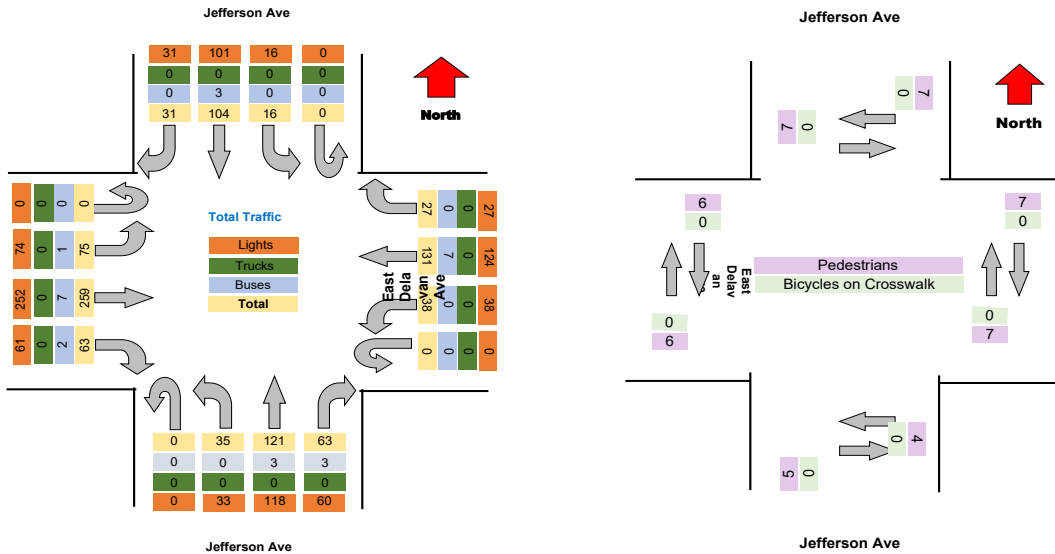

Project : VBH Malta NY  
 Site : Site 4  
 Location : 42.948550, -73.790036

TSTData.com

Survey Date : 2021-04-28, Wednesday

Project	LaBella
Project Code	LaBella
Site Name	30
Legs and Movements	All Processed Legs & Move
Bin Size	15 minutes
Survey Date	2021-11-02, Tuesday
Location	30
Latitude and Longitude	42.919362, -78.853974

	Start	End	PHF
Forced Peak AM	2021/11/02 07:30:00	2021/11/02 08:30:00	0.9
Forced Peak PM	2021/11/02 16:30:00	2021/11/02 17:30:00	0.94
AM Peak	2021/11/02 07:30:00	2021/11/02 08:30:00	0.9
PM Peak	2021/11/02 17:00:00	2021/11/02 18:00:00	0.85

### Turning Movement Data

Leg Direction	Jefferson Ave									Northland Ave									Jefferson Ave									Northland Ave									Total
	Southbound									Westbound									Northbound									Eastbound									
	Right	Thru	Left	U-Turn	App Total	Peds CV	Peds CCV	Right	Thru	Left	U-Turn	App Total	Peds CV	Peds CCV	Right	Thru	Left	U-Turn	App Total	Peds CV	Peds CCV	Right	Thru	Left	U-Turn	App Total	Peds CV	Peds CCV									
6:30:00 AM	1	10	0	0	11	0	0	0	1	2	0	3	0	0	2	15	0	0	17	0	0	1	1	0	2	1	0	33									
6:45:00 AM	0	11	1	0	12	0	0	1	1	1	0	3	0	0	4	13	0	0	17	0	0	0	0	1	0	1	0	33									
Hourly Total	1	21	1	0	23	0	0	1	2	3	0	6	0	0	6	28	0	0	34	0	0	1	1	1	0	3	1	0	66								
7:00:00 AM	1	9	2	0	12	0	0	3	0	2	0	5	0	0	2	41	2	0	45	0	0	1	0	1	0	2	0	1	64								
7:15:00 AM	1	14	1	0	16	0	0	3	1	2	0	6	0	0	3	23	0	0	26	0	0	2	1	2	0	5	0	0	53								
7:30:00 AM	2	14	1	0	17	0	0	1	1	1	0	3	0	0	0	24	0	0	24	0	0	1	2	1	0	4	0	0	48								
7:45:00 AM	1	23	4	0	28	0	0	1	2	0	0	3	0	0	1	26	1	0	28	0	0	1	2	0	0	3	0	0	62								
Hourly Total	5	60	8	0	73	0	0	8	4	5	0	17	0	0	6	114	3	0	123	0	0	5	5	4	0	14	0	1	227								
8:00:00 AM	1	20	3	0	24	1	0	1	4	1	0	6	0	0	3	20	0	0	23	0	0	3	1	2	0	6	0	0	59								
8:15:00 AM	1	28	0	0	29	0	0	2	0	2	0	4	0	0	0	15	0	0	15	0	0	2	2	2	0	6	0	0	54								
Hourly Total	2	48	3	0	53	1	0	3	4	3	0	10	0	0	3	35	0	0	38	0	0	5	3	4	0	12	0	0	113								
4:00:00 PM	4	46	5	0	55	0	0	5	8	5	0	18	0	0	7	43	4	0	54	4	4	3	3	7	0	13	4	1	140								
4:15:00 PM	4	44	11	0	59	0	0	2	4	7	0	13	0	0	7	44	3	0	54	2	2	3	3	6	0	12	5	2	138								
4:30:00 PM	4	51	7	0	62	0	0	4	5	6	0	17	1	0	7	48	3	0	58	4	3	2	2	1	0	5	4	3	142								
4:45:00 PM	4	37	6	0	47	1	0	3	3	6	0	12	2	0	7	45	3	0	55	2	1	0	3	3	0	6	5	4	120								
Hourly Total	16	178	29	0	223	1	0	14	20	26	0	60	3	0	28	150	13	0	221	12	10	8	11	17	0	38	19	10	540								
5:00:00 PM	5	42	4	1	52	1	0	2	3	3	0	8	0	2	13	40	5	0	59	3	1	4	7	4	0	15	3	2	133								
5:15:00 PM	5	42	7	0	54	0	0	4	10	0	0	14	1	1	4	49	4	0	57	3	2	5	5	5	0	15	4	4	140								
5:30:00 PM	2	30	4	0	36	0	0	1	5	2	0	8	0	1	7	43	2	0	52	1	3	0	2	3	0	5	6	1	101								
5:45:00 PM	4	32	9	0	45	0	0	2	2	3	0	7	0	0	1	41	3	0	45	2	2	0	7	0	0	7	5	6	104								
Hourly Total	16	146	24	1	187	1	0	9	20	8	0	37	1	4	25	173	14	0	212	9	8	9	21	12	0	42	18	13	478								
Grand Total	40	453	65	1	559	3	0	35	50	45	0	130	4	4	66	530	30	0	628	21	18	28	41	38	0	107	38	24	1424								
% Approach	7.2%	81.0%	11.6%	0.2%	0.0%	0.0%	0.0%	26.9%	38.5%	34.6%	0.0%	0.0%	0.0%	10.8%	84.4%	4.8%	0.0%	0.0%	0.0%	0.0%	26.2%	38.3%	35.5%	0.0%	0.0%	0.0%	0.0%	0.0%	0.0%								
% Total	2.8%	31.8%	4.6%	0.1%	39.3%	0.0%	0.0%	2.5%	3.5%	3.2%	0.0%	8.1%	0.0%	0.0%	4.8%	37.2%	2.1%	0.0%	44.1%	0.0%	0.0%	2.0%	2.9%	2.7%	0.0%	7.5%	0.0%	0.0%	0.0%								
Lights	40	443	64	1	548	0	0	33	50	43	0	126	0	0	67	520	30	0	617	0	0	27	40	35	0	102	0	0	1393								
% Lights	100.0%	97.8%	98.5%	100.0%	98.0%	0.0%	0.0%	94.3%	100.0%	95.6%	0.0%	96.9%	0.0%	0.0%	95.5%	98.1%	100.0%	0.0%	98.2%	0.0%	0.0%	96.4%	97.6%	92.1%	0.0%	95.3%	0.0%	0.0%	97.8%								
Trucks	0	0	0	0	0	0	0	0	0	0	0	0	0	0	0	0	0	0	0	0	0	0	0	0	0	0	0	0	0								
% Trucks	0.0%	0.0%	0.0%	0.0%	0.0%	0.0%	0.0%	0.0%	0.0%	0.0%	0.0%	0.0%	0.0%	0.0%	0.0%	0.0%	0.0%	0.0%	0.0%	0.0%	0.0%	0.0%	0.0%	0.0%	0.0%	0.0%	0.0%	0.0%	0.0%	0.0%							
Buses	0	9	1	0	10	0	0	2	0	2	0	4	0	0	1	10	0	0	11	0	0	1	1	3	0	5	0	0	30								
% Buses	0.0%	2.0%	1.5%	0.0%	0.0%	0.0%	0.0%	0.0%	0.0%	4.4%	0.0%	0.0%	0.0%	0.0%	1.5%	1.9%	0.0%	0.0%	0.0%	0.0%	0.0%	3.6%	2.4%	7.9%	0.0%	0.0%	0.0%	0.0%	2.1%								
Pedestrians	0	0	0	0	0	3	0	0	0	0	0	0	4	4	0	0	0	0	0	21	18	0	0	0	0	0	34	23	0								
% Pedestrians	0.0%	0.0%	0.0%	0.0%	0.0%	100.0%	0.0%	0.0%	0.0%	0.0%	0.0%	0.0%	100.0%	100.0%	0.0%	0.0%	0.0%	0.0%	0.0%	100.0%	100.0%	0.0%	0.0%	0.0%	0.0%	0.0%	0.0%	89.6%	85.8%	0.0%							
Bicycles on Crosswalk	0	0	0	0	0	0	0	0	0	0	0	0	0	0	0	0	0	0	0	0	0	0	0	0	0	0	4	1	0								
% Bicycles on Crosswalk	0.0%	0.0%	0.0%	0.0%	0.0%	0.0%	0.0%	0.0%	0.0%	0.0%	0.0%	0.0%	0.0%	0.0%	0.0%	0.0%	0.0%	0.0%	0.0%	0.0%	0.0%	0.0%	0.0%	0.0%	0.0%	0.0%	0.0%	10.5%	4.2%	0.0%							

Project : VBH Malta NY  
 Site : Site 4  
 Location : 42.948550, -73.790036  
 Survey Date : 2021-04-28, Wednesday

### Turning Movement Data Plot

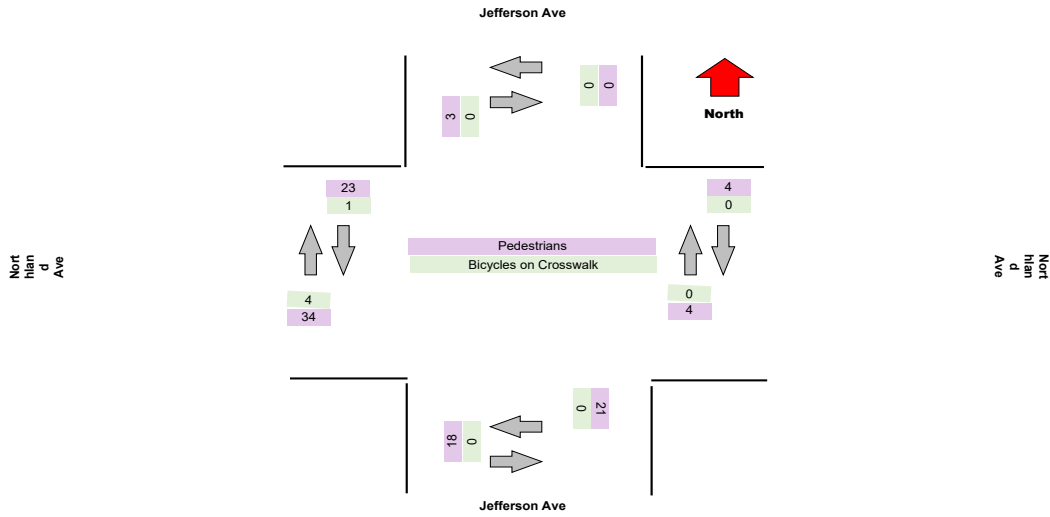
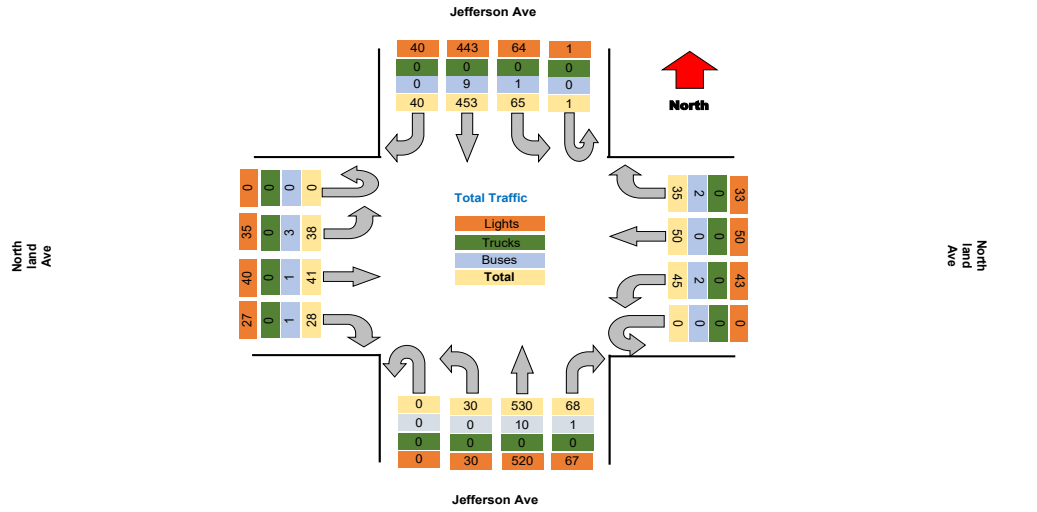



Project : VBH Malta NY  
Site : Site 4  
Location : 42.948550, -73.790036

TSTData.com

Survey Date : 2021-04-28, Wednesday

### Turning Movement Peak Hour Data (AM)

7:30:00 AM

Leg Direction	Jefferson Ave				Northland Ave				Jefferson Ave				Northland Ave				Total											
	Right	Thru	Left	U-Turn	Right	Thru	Left	U-Turn	Right	Thru	Left	U-Turn	Right	Thru	Left	U-Turn												
7:30:00 AM	2	14	1	0	1	1	1	0	0	24	0	0	1	2	1	0	4	48										
7:45:00 AM	1	23	4	0	1	2	0	0	3	0	0	0	1	2	0	0	3	62										
8:00:00 AM	1	20	3	0	1	4	1	0	6	0	0	0	3	2	0	0	6	59										
8:15:00 AM	1	28	0	0	2	0	2	0	4	0	0	0	0	2	2	0	6	54										
<b>Grand Total</b>	<b>5</b>	<b>85</b>	<b>8</b>	<b>0</b>	<b>5</b>	<b>7</b>	<b>4</b>	<b>0</b>	<b>16</b>	<b>0</b>	<b>0</b>	<b>0</b>	<b>4</b>	<b>85</b>	<b>1</b>	<b>0</b>	<b>19</b>	<b>223</b>										
% Approach	5.1%	86.7%	8.2%	0.0%	31.3%	43.8%	25.0%	0.0%	0.0%	4.4%	94.4%	1.1%	0.0%	0.0%	0.0%	0.0%	36.8%	36.8%	26.3%	0.0%	0.0%	0.0%						
% Total	2.2%	38.1%	3.6%	0.0%	2.2%	3.1%	1.8%	0.0%	7.2%	0.0%	0.0%	0.0%	1.8%	38.1%	0.4%	0.0%	40.4%	0.0%	0.0%	3.1%	3.1%	2.2%	0.0%	8.5%	0.0%	0.0%		
PHF	0.625	0.759	0.500	0.000	0.845	0.000	0.000	0.000	0.667	0.000	0.000	0.000	0.333	0.817	0.250	0.000	0.804	0.000	0.000	0.583	0.875	0.625	0.000	0.792	0.000	0.000	0.899	
Lights	5	83	8	0	5	7	4	0	16	0	0	0	4	82	1	0	87	0	0	7	7	5	0	19	0	0	218	
% Lights	100.0%	97.6%	100.0%	0.0%	100.0%	100.0%	100.0%	0.0%	100.0%	0.0%	0.0%	0.0%	100.0%	96.5%	100.0%	0.0%	96.7%	0.0%	0.0%	100.0%	100.0%	100.0%	0.0%	100.0%	0.0%	0.0%	97.8%	
Trucks	0	0	0	0	0	0	0	0	0	0	0	0	0	0	0	0	0	0	0	0	0	0	0	0	0	0	0	0
% Trucks	0.0%	0.0%	0.0%	0.0%	0.0%	0.0%	0.0%	0.0%	0.0%	0.0%	0.0%	0.0%	0.0%	0.0%	0.0%	0.0%	0.0%	0.0%	0.0%	0.0%	0.0%	0.0%	0.0%	0.0%	0.0%	0.0%	0.0%	0.0%
Buses	0	2	0	0	0	0	0	0	0	0	0	0	0	3	0	0	3	0	0	0	0	0	0	0	0	0	0	5
% Buses	0.0%	2.4%	0.0%	0.0%	0.0%	0.0%	0.0%	0.0%	0.0%	0.0%	0.0%	0.0%	0.0%	3.5%	0.0%	0.0%	3.0%	0.0%	0.0%	0.0%	0.0%	0.0%	0.0%	0.0%	0.0%	0.0%	0.0%	2.2%
Pedestrians	0	0	0	0	0	0	0	0	0	0	0	0	0	0	0	0	0	0	0	0	0	0	0	0	0	0	0	0
% Pedestrians	0.0%	0.0%	0.0%	0.0%	0.0%	0.0%	0.0%	0.0%	0.0%	0.0%	0.0%	0.0%	0.0%	0.0%	0.0%	0.0%	0.0%	0.0%	0.0%	0.0%	0.0%	0.0%	0.0%	0.0%	0.0%	0.0%	0.0%	0.0%
Bicycles on Crosswalk	0	0	0	0	0	0	0	0	0	0	0	0	0	0	0	0	0	0	0	0	0	0	0	0	0	0	0	0
% Bicycles on Crosswalk	0.0%	0.0%	0.0%	0.0%	0.0%	0.0%	0.0%	0.0%	0.0%	0.0%	0.0%	0.0%	0.0%	0.0%	0.0%	0.0%	0.0%	0.0%	0.0%	0.0%	0.0%	0.0%	0.0%	0.0%	0.0%	0.0%	0.0%	0.0%

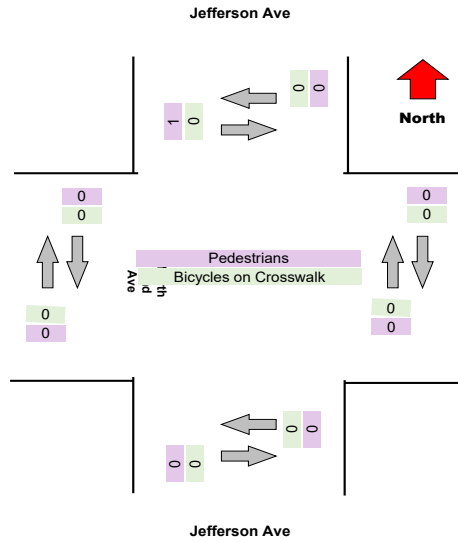
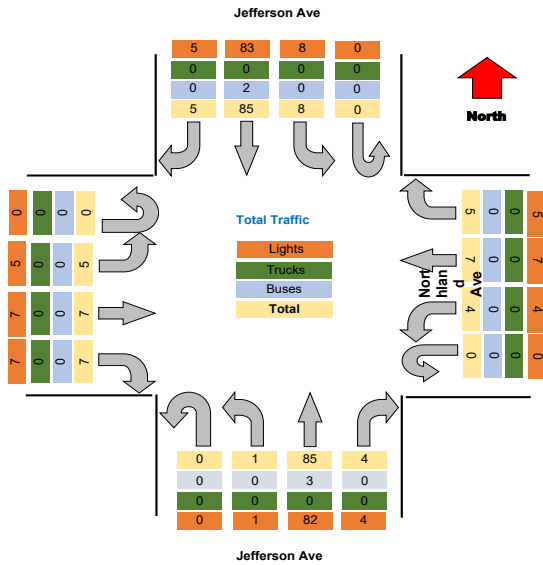

**Turning Movement Peak Hour Data (PM)**

5:00:00 PM

Leg Direction	Jefferson Ave										Northland Ave										Total										
	Southbound					Westbound					Northbound					Eastbound															
	Right	Thru	Left	U-Turn	App Total	Peds CW	Peds CCW	Right	Thru	Left	U-Turn	App Total	Peds CW	Peds CCW	Right	Thru	Left	U-Turn	App Total	Peds CW		Peds CCW									
5:00:00 PM	5	42	4	1	52	1	0	2	3	3	0	8	0	2	13	40	5	0	58	3	1	4	7	4	0	15	3	2	133		
5:15:00 PM	5	42	7	0	54	0	0	4	10	0	0	14	1	1	4	49	4	0	57	3	2	5	5	5	0	15	4	4	140		
5:30:00 PM	2	30	4	0	36	0	0	1	5	2	0	8	0	1	7	43	2	0	52	1	3	0	2	3	0	5	6	1	101		
5:45:00 PM	4	32	9	0	45	0	0	2	2	3	0	7	0	0	1	41	3	0	45	2	2	0	7	0	0	7	5	6	104		
<b>Grand Total</b>	16	146	24	1	187	1	0	9	20	8	0	37	1	4	25	173	14	0	212	3	6	9	21	12	0	42	15	13	478		
% Approach	8.6%	78.1%	12.8%	0.5%	0.0%	0.0%	0.0%	24.3%	54.1%	21.6%	0.0%	0.0%	0.0%	0.0%	11.8%	81.6%	6.6%	0.0%	0.0%	0.0%	0.0%	21.4%	50.0%	28.6%	0.0%	0.0%	0.0%	0.0%	0.0%		
% Total	3.3%	30.5%	5.0%	0.2%	38.1%	0.0%	0.0%	1.9%	4.2%	1.7%	0.0%	7.7%	0.0%	0.0%	5.2%	36.2%	2.9%	0.0%	44.4%	0.0%	0.0%	1.9%	4.4%	2.5%	0.0%	8.8%	0.0%	0.0%	0.0%		
PHF	0.800	0.869	0.667	0.250	0.866	0.000	0.000	0.563	0.500	0.667	0.000	0.661	0.000	0.000	0.481	0.883	0.700	0.000	0.814	0.000	0.000	0.450	0.750	0.600	0.000	0.700	0.000	0.000	0.854		
Lights	16	144	24	1	185	0	0	9	20	8	0	37	0	0	25	171	14	0	210	0	0	9	21	12	0	42	0	0	474		
% Lights	100.0%	98.6%	100.0%	100.0%	98.9%	0.0%	0.0%	100.0%	100.0%	100.0%	0.0%	100.0%	0.0%	0.0%	100.0%	98.8%	100.0%	0.0%	99.1%	0.0%	0.0%	100.0%	100.0%	100.0%	0.0%	100.0%	0.0%	0.0%	99.2%		
Trucks	0	0	0	0	0	0	0	0	0	0	0	0	0	0	0	0	0	0	0	0	0	0	0	0	0	0	0	0	0		
% Trucks	0.0%	0.0%	0.0%	0.0%	0.0%	0.0%	0.0%	0.0%	0.0%	0.0%	0.0%	0.0%	0.0%	0.0%	0.0%	0.0%	0.0%	0.0%	0.0%	0.0%	0.0%	0.0%	0.0%	0.0%	0.0%	0.0%	0.0%	0.0%	0.0%		
Buses	0	2	0	0	2	0	0	0	0	0	0	0	0	0	0	2	0	0	2	0	0	0	0	0	0	0	0	0	4		
% Buses	0.0%	1.4%	0.0%	0.0%	0.0%	0.0%	0.0%	0.0%	0.0%	0.0%	0.0%	0.0%	0.0%	0.0%	0.0%	1.2%	0.0%	0.0%	0.0%	0.0%	0.0%	0.0%	0.0%	0.0%	0.0%	0.0%	0.0%	0.0%	0.8%		
Pedestrians	0	0	0	0	0	1	0	0	0	0	0	1	4	0	0	0	0	0	0	9	8	0	0	0	0	0	0	18	12	0	
% Pedestrians	0.0%	0.0%	0.0%	0.0%	0.0%	100.0%	0.0%	0.0%	0.0%	0.0%	0.0%	0.0%	100.0%	100.0%	0.0%	0.0%	0.0%	0.0%	0.0%	0.0%	100.0%	100.0%	0.0%	0.0%	0.0%	0.0%	0.0%	0.0%	100.0%	92.3%	0.0%
Bicycles on Crosswalk	0	0	0	0	0	0	0	0	0	0	0	0	0	0	0	0	0	0	0	0	0	0	0	0	0	0	0	0	1	0	
% Bicycles on Crosswalk	0.0%	0.0%	0.0%	0.0%	0.0%	0.0%	0.0%	0.0%	0.0%	0.0%	0.0%	0.0%	0.0%	0.0%	0.0%	0.0%	0.0%	0.0%	0.0%	0.0%	0.0%	0.0%	0.0%	0.0%	0.0%	0.0%	0.0%	7.7%	0.0%		

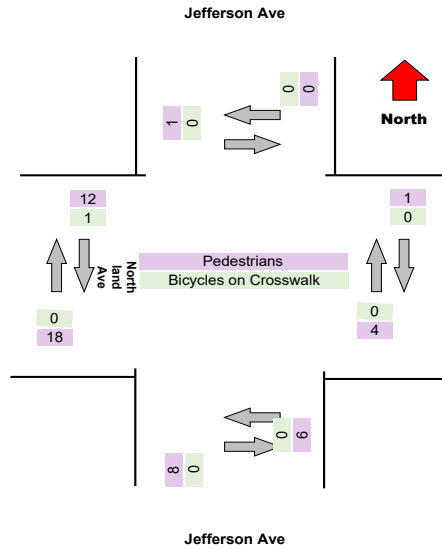
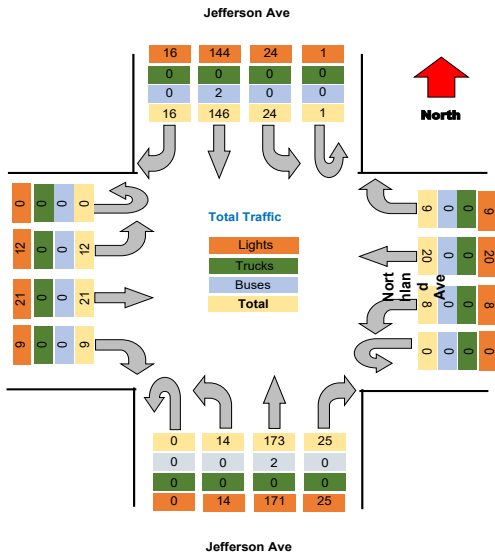

Project : VBH Malta NY  
 Site : Site 4  
 Location : 42.948550, -73.790036

TSTData.com

Survey Date : 2021-04-28, Wednesday

Project	LaBella
Project Code	LaBella
Site Name	30
Legs and Movements	All Processed Legs & Move
Bin Size	15 minutes
Survey Date	2021-11-03, Wednesday
Location	30
Latitude and Longitude	42.919362, -78.853974

	Start	End	PHF
Forced Peak AM	2021/11/03 07:30:00	2021/11/03 08:30:00	0.83
Forced Peak PM	2021/11/03 16:30:00	2021/11/03 17:30:00	0.84
AM Peak	2021/11/03 07:30:00	2021/11/03 08:30:00	0.83
PM Peak	2021/11/03 17:00:00	2021/11/03 18:00:00	0.91

### Turning Movement Data

Leg Direction	Jefferson Ave							Northland Ave							Jefferson Ave							Northland Ave							Total							
	Southbound			Westbound				Northbound			Westbound				Northbound			Eastbound																		
Start Time	Right	Thru	Left	U-Turn	App Total	Peds CV	Peds CCV	Right	Thru	Left	U-Turn	App Total	Peds CV	Peds CCV	Right	Thru	Left	U-Turn	App Total	Peds CV	Peds CCV	Right	Thru	Left	U-Turn	App Total	Peds CV	Peds CCV								
6:30:00 AM	3	11	0	0	14	0	0	0	0	2	0	2	0	1	0	15	0	0	16	0	0	1	2	0	0	3	0	0	2	1	0	0	3	0	0	35
6:45:00 AM	1	17	1	0	19	0	0	0	1	2	0	4	0	1	2	16	2	0	21	0	0	2	1	0	0	3	0	0	3	0	0	0	3	0	0	47
Hourly Total	4	28	1	0	33	0	0	0	1	4	0	6	0	2	2	31	2	0	37	0	0	3	3	0	0	6	0	0	6	0	0	0	6	0	0	82
7:00:00 AM	0	21	1	0	22	0	0	3	0	3	0	6	0	0	1	32	1	0	34	0	0	2	2	1	0	5	2	2	2	2	1	0	5	2	2	87
7:15:00 AM	4	15	2	0	21	0	0	1	2	1	0	4	0	1	1	28	1	0	31	0	0	1	3	4	0	8	0	0	1	3	4	0	8	0	0	64
7:30:00 AM	4	18	3	0	25	0	0	1	0	3	0	4	0	0	2	31	1	0	34	0	0	1	4	1	0	6	1	0	1	4	1	0	6	1	0	69
7:45:00 AM	4	48	1	0	53	0	1	7	2	5	0	15	0	1	0	23	5	0	29	0	0	5	2	5	0	12	1	2	12	1	2	0	15	2	4	109
Hourly Total	12	102	7	0	121	0	1	12	4	12	0	29	0	2	4	114	8	0	128	0	0	9	11	11	0	31	4	4	31	4	4	0	39	6	8	309
8:00:00 AM	3	29	6	0	38	0	0	0	1	1	0	2	1	1	3	37	3	0	46	0	0	1	7	3	0	11	2	0	1	7	3	0	11	2	0	96
8:15:00 AM	2	25	0	0	27	0	0	5	2	4	0	11	0	0	2	35	1	0	38	0	0	2	7	4	0	13	0	1	2	7	4	0	13	0	1	89
Hourly Total	5	54	6	0	65	0	0	5	3	5	0	13	1	1	5	72	4	0	83	0	0	3	14	7	0	24	2	1	24	2	1	0	27	3	1	185
4:00:00 PM	4	47	2	0	53	1	0	7	3	3	0	13	0	0	8	56	3	0	67	1	2	4	6	4	0	14	5	6	4	6	4	0	14	5	6	147
4:15:00 PM	1	54	6	0	61	0	0	4	6	4	0	14	1	0	7	54	3	2	66	5	5	1	8	7	0	16	4	7	1	8	7	0	16	4	7	157
4:30:00 PM	5	62	9	0	76	0	0	4	8	5	0	17	0	0	4	46	6	0	56	2	1	10	7	5	0	22	4	0	10	7	5	0	22	4	0	171
4:45:00 PM	2	36	2	0	40	0	0	6	1	3	0	10	1	1	4	47	2	2	55	2	3	3	7	6	0	16	4	1	3	7	6	0	16	4	1	121
Hourly Total	12	199	19	0	230	1	0	21	18	15	0	54	2	1	23	203	14	4	244	10	11	18	28	22	0	68	17	14	68	17	14	0	99	31	28	596
5:00:00 PM	5	40	4	0	49	0	0	5	6	3	0	14	0	0	4	51	5	0	60	1	2	2	11	11	0	24	3	3	2	11	11	0	24	3	3	147
5:15:00 PM	3	39	4	0	46	3	0	2	2	2	0	6	0	0	7	51	7	0	65	5	4	8	6	4	0	18	4	4	8	6	4	0	18	4	4	135
5:30:00 PM	2	45	5	0	52	0	0	6	3	3	0	12	1	0	14	43	5	0	62	2	2	4	4	4	0	12	1	6	4	4	4	0	12	1	6	138
5:45:00 PM	2	38	5	0	45	0	0	4	4	3	0	11	0	0	2	43	5	0	50	2	2	2	4	6	0	12	2	3	2	4	6	0	12	2	3	118
Hourly Total	12	162	18	0	192	3	0	17	15	11	0	43	1	0	27	188	22	0	237	10	10	16	25	25	0	66	10	16	16	25	25	0	66	10	16	538
Grand Total	45	545	51	0	641	4	2	55	41	47	0	145	4	6	61	608	50	4	729	20	21	49	81	65	0	195	33	35	49	81	65	0	195	33	35	1710
% Approach	7.0%	85.0%	8.0%	0.0%	0.0%	0.0%	0.0%	37.9%	28.3%	32.4%	0.0%	0.0%	0.0%	0.0%	8.4%	83.4%	6.9%	0.5%	0.0%	0.0%	0.0%	25.1%	41.5%	33.3%	0.0%	0.0%	0.0%	0.0%	0.0%	0.0%	0.0%	0.0%	0.0%	0.0%	0.0%	0.0%
% Total	2.6%	31.9%	3.0%	0.0%	37.5%	0.0%	0.0%	3.2%	2.4%	2.7%	0.0%	8.5%	0.0%	0.0%	3.6%	35.6%	2.9%	0.2%	42.6%	0.0%	0.0%	2.9%	4.7%	3.8%	0.0%	11.4%	0.0%	0.0%	11.4%	0.0%	0.0%	0.0%	11.4%	0.0%	0.0%	0.0%
Lights	44	522	46	0	612	0	0	49	39	40	0	128	0	0	60	574	45	4	683	0	0	45	72	58	0	175	0	0	45	72	58	0	175	0	0	1598
% Lights	97.8%	95.6%	90.2%	0.0%	95.2%	0.0%	0.0%	99.1%	95.1%	85.1%	0.0%	98.3%	0.0%	0.0%	98.4%	84.4%	90.0%	100.0%	93.7%	0.0%	0.0%	91.8%	88.9%	89.2%	0.0%	89.7%	0.0%	0.0%	89.7%	0.0%	0.0%	0.0%	89.7%	0.0%	0.0%	93.8%
Trucks	0	1	0	0	1	0	0	0	0	0	0	0	0	0	0	1	0	0	1	0	0	0	0	0	0	0	0	0	0	0	0	0	0	0	0	2
% Trucks	0.0%	0.2%	0.0%	0.0%	0.2%	0.0%	0.0%	0.0%	0.0%	0.0%	0.0%	0.0%	0.0%	0.0%	0.0%	0.2%	0.0%	0.0%	0.1%	0.0%	0.0%	0.0%	0.0%	0.0%	0.0%	0.0%	0.0%	0.0%	0.0%	0.0%	0.0%	0.0%	0.0%	0.0%	0.0%	0.1%
Buses	1	22	5	0	28	0	0	6	2	7	0	15	0	0	1	33	5	0	39	0	0	4	9	7	0	20	0	0	4	9	7	0	20	0	0	102
% Buses	2.2%	4.0%	9.8%	0.0%	0.0%	0.0%	0.0%	0.0%	4.9%	14.9%	0.0%	0.0%	0.0%	0.0%	1.6%	5.4%	10.0%	0.0%	0.0%	0.0%	0.0%	8.2%	11.1%	10.8%	0.0%	0.0%	0.0%	0.0%	8.2%	11.1%	10.8%	0.0%	0.0%	0.0%	0.0%	6.0%
Pedestrians	0	0	0	0	0	4	2	0	0	0	0	0	4	6	0	0	0	0	0	20	21	0	0	0	0	0	0	0	0	0	0	0	0	32	33	0
% Pedestrians	0.0%	0.0%	0.0%	0.0%	0.0%	100.0%	100.0%	0.0%	0.0%	0.0%	0.0%	0.0%	100.0%	100.0%	0.0%	0.0%	0.0%	0.0%	0.0%	100.0%	100.0%	0.0%	0.0%	0.0%	0.0%	0.0%	0.0%	0.0%	0.0%	0.0%	0.0%	0.0%	0.0%	87.0%	84.3%	0.0%
Bicycles on Crosswalk	0	0	0	0	0	0	0	0	0	0	0	0	0	0	0	0	0	0	0	0	0	0	0	0	0	0	1	2	0	1	2	0	0			
% Bicycles on Crosswalk	0.0%	0.0%	0.0%	0.0%	0.0%	0.0%	0.0%	0.0%	0.0%	0.0%	0.0%	0.0%	0.0%	0.0%	0.0%	0.0%	0.0%	0.0%	0.0%	0.0%	0.0%	0.0%	0.0%	0.0%	0.0%	0.0%	0.0%	0.0%	0.0%	0.0%	0.0%	0.0%	0.0%	3.0%	5.7%	0.0%

Project : VBH Malta NY  
 Site : Site 4  
 Location : 42.948550, -73.790036  
 Survey Date : 2021-04-28, Wednesday

### Turning Movement Data Plot

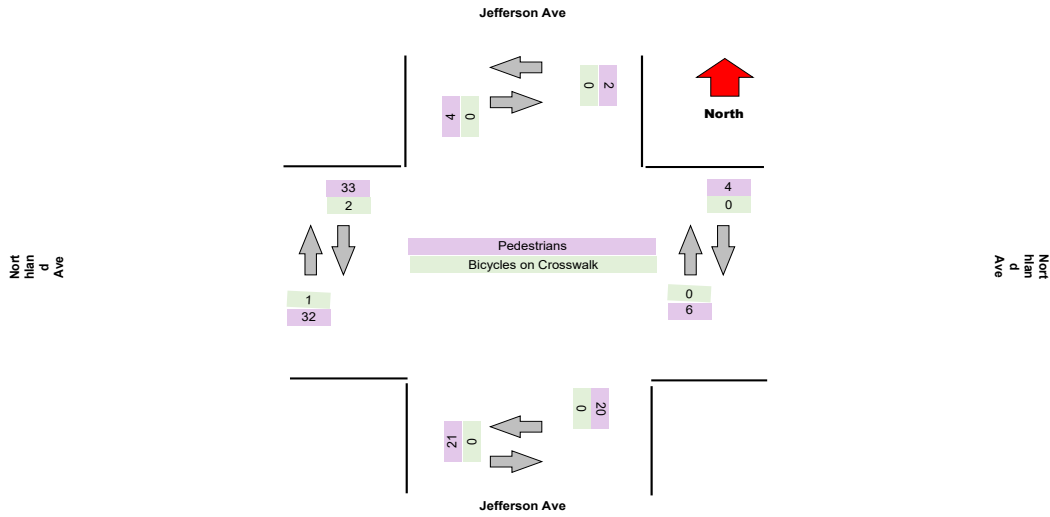
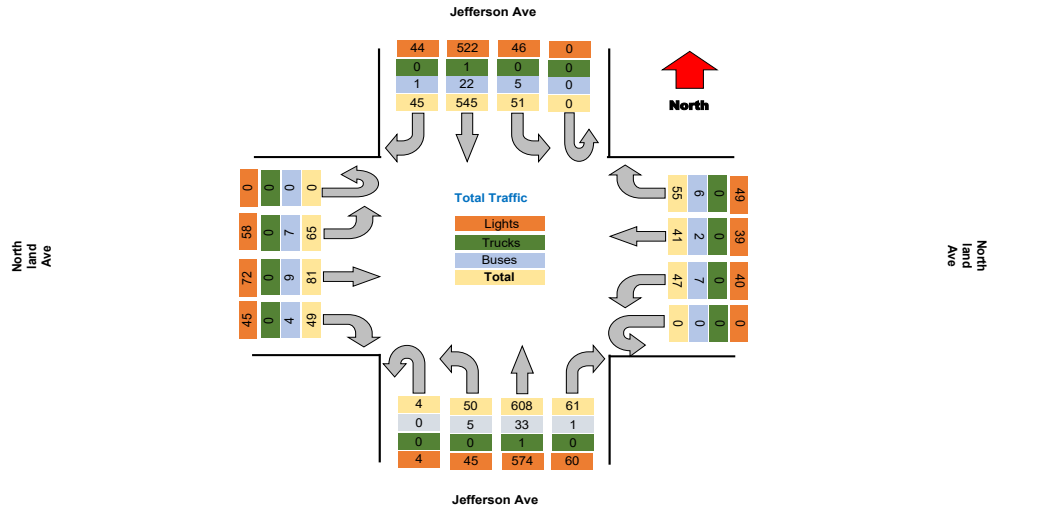

**Turning Movement Peak Hour Data (AM)**

7:30:00 AM

Leg Direction	Jefferson Ave				Northland Ave				Jefferson Ave				Northland Ave				Total				
	Right	Thru	Left	U-Turn	Right	Thru	Left	U-Turn	Right	Thru	Left	U-Turn	Right	Thru	Left	U-Turn					
7:30:00 AM	4	18	3	0	1	0	3	0	2	31	1	0	1	4	1	0	6	1	0	69	
7:45:00 AM	4	48	1	0	7	2	5	0	0	23	5	0	2	2	5	0	12	1	2	109	
8:00:00 AM	3	29	6	0	0	1	1	0	2	37	3	0	3	7	3	0	11	2	0	96	
8:15:00 AM	2	25	0	0	5	2	4	0	11	35	1	0	2	7	4	0	13	0	1	89	
<b>Grand Total</b>	<b>13</b>	<b>129</b>	<b>10</b>	<b>0</b>	<b>13</b>	<b>5</b>	<b>13</b>	<b>0</b>	<b>32</b>	<b>7</b>	<b>125</b>	<b>10</b>	<b>0</b>	<b>9</b>	<b>20</b>	<b>13</b>	<b>42</b>	<b>3</b>	<b>3</b>	<b>383</b>	
% Approach	9.1%	83.9%	7.0%	0.0%	40.6%	15.6%	40.6%	0.0%	0.0%	4.8%	96.3%	6.8%	0.0%	21.4%	47.6%	31.0%	0.0%	0.0%	0.0%	0.0%	
% Total	3.6%	33.1%	2.8%	0.0%	3.6%	1.4%	3.6%	0.0%	8.8%	1.9%	34.7%	2.8%	0.0%	2.5%	5.5%	3.6%	0.0%	11.6%	0.0%	0.0%	
PHF	0.813	0.625	0.417	0.000	0.675	0.000	0.000	0.000	0.533	0.583	0.851	0.500	0.000	0.811	0.000	0.000	0.450	0.714	0.650	0.000	0.833
Lights	13	114	8	0	13	5	12	0	29	7	115	8	0	8	18	12	0	38	0	0	332
% Lights	100.0%	95.0%	80.0%	0.0%	94.4%	0.0%	0.0%	0.0%	90.6%	100.0%	91.3%	80.0%	0.0%	88.9%	90.0%	92.3%	0.0%	90.5%	0.0%	0.0%	91.5%
Trucks	0	0	0	0	0	0	0	0	0	0	0	0	0	0	0	0	0	0	0	0	0
% Trucks	0.0%	0.0%	0.0%	0.0%	0.0%	0.0%	0.0%	0.0%	0.0%	0.0%	0.0%	0.0%	0.0%	0.0%	0.0%	0.0%	0.0%	0.0%	0.0%	0.0%	0.0%
Buses	0	6	2	0	1	0	1	0	2	0	11	2	0	1	2	1	0	4	0	0	27
% Buses	0.0%	5.0%	20.0%	0.0%	0.0%	0.0%	0.0%	0.0%	7.7%	0.0%	8.7%	20.0%	0.0%	11.1%	10.0%	7.7%	0.0%	0.0%	0.0%	0.0%	7.4%
Pedestrians	0	0	0	0	0	0	0	0	1	0	0	0	0	0	0	0	0	0	3	1	0
% Pedestrians	0.0%	0.0%	0.0%	0.0%	0.0%	0.0%	0.0%	0.0%	3.1%	0.0%	0.0%	0.0%	0.0%	0.0%	0.0%	0.0%	0.0%	0.0%	7.5%	33.3%	0.0%
Bicycles on Crosswalk	0	0	0	0	0	0	0	0	0	0	0	0	0	0	0	0	0	0	1	2	0
% Bicycles on Crosswalk	0.0%	0.0%	0.0%	0.0%	0.0%	0.0%	0.0%	0.0%	0.0%	0.0%	0.0%	0.0%	0.0%	0.0%	0.0%	0.0%	0.0%	0.0%	25.0%	66.7%	0.0%

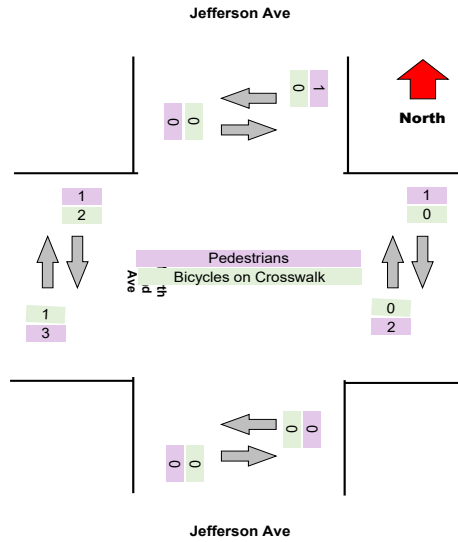
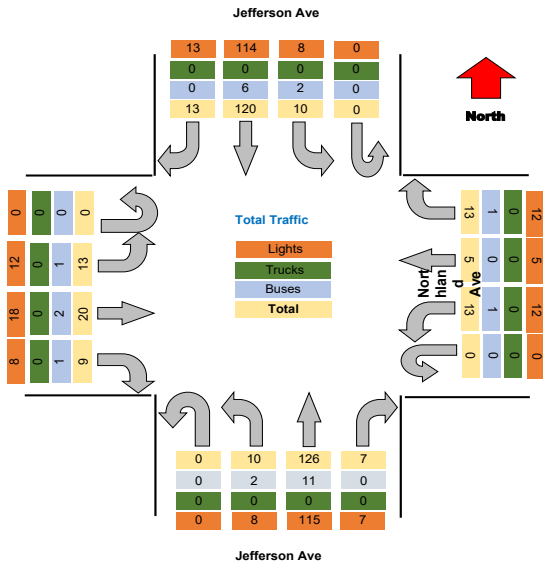

**Turning Movement Peak Hour Data (PM)**

5:00:00 PM

Leg Direction	Jefferson Ave										Northland Ave										Jefferson Ave										Northland Ave										Total
	Southbound					Westbound					Northbound					Eastbound																									
	Right	Thru	Left	U-Turn	App Total	Peds CW	Peds CCW	Right	Thru	Left	U-Turn	App Total	Peds CW	Peds CCW	Right	Thru	Left	U-Turn	App Total	Peds CW	Peds CCW	Right	Thru	Left	U-Turn	App Total	Peds CW	Peds CCW													
5:00:00 PM	5	40	4	0	49	0	0	5	6	3	0	14	0	0	4	51	5	0	60	1	2	2	11	11	0	24	3	3	147												
5:15:00 PM	3	39	4	0	46	3	0	2	2	2	0	6	0	0	7	51	7	0	65	5	4	8	6	4	0	18	4	4	136												
5:30:00 PM	2	45	5	0	52	0	0	6	3	3	0	12	1	0	14	43	5	0	62	2	2	4	4	4	0	12	1	6	138												
5:45:00 PM	2	39	5	0	45	0	0	4	4	3	0	11	0	0	2	43	5	0	50	2	2	2	4	6	0	12	2	3	118												
<b>Grand Total</b>	12	162	18	0	192	3	0	17	15	11	0	42	1	0	27	188	22	0	237	10	10	16	25	25	0	66	15	16	538												
% Approach	6.3%	84.4%	9.4%	0.0%	0.0%	0.0%	0.0%	39.5%	34.9%	25.6%	0.0%	0.0%	0.0%	0.0%	11.4%	79.3%	9.3%	0.0%	0.0%	0.0%	0.0%	24.2%	37.9%	37.9%	0.0%	0.0%	0.0%	0.0%	0.0%												
% Total	2.2%	30.1%	3.3%	0.0%	35.7%	0.0%	0.0%	3.2%	2.8%	2.0%	0.0%	8.0%	0.0%	0.0%	5.0%	34.9%	4.1%	0.0%	44.1%	0.0%	0.0%	3.0%	4.6%	4.6%	0.0%	12.3%	0.0%	0.0%	0.0%												
PHF	0.600	0.900	0.900	0.000	0.923	0.000	0.000	0.708	0.625	0.917	0.000	0.768	0.000	0.000	0.482	0.922	0.786	0.000	0.912	0.000	0.000	0.500	0.568	0.568	0.000	0.688	0.000	0.000	0.915												
Lights	12	158	17	0	187	0	0	16	15	11	0	42	0	0	27	180	22	0	229	0	0	16	25	23	0	64	0	0	522												
% Lights	100.0%	97.5%	94.4%	0.0%	97.4%	0.0%	0.0%	84.1%	100.0%	100.0%	0.0%	97.7%	0.0%	0.0%	100.0%	95.7%	100.0%	0.0%	96.6%	0.0%	0.0%	100.0%	100.0%	92.0%	0.0%	97.0%	0.0%	0.0%	97.0%												
Trucks	0	0	0	0	0	0	0	0	0	0	0	0	0	0	1	0	0	1	0	0	0	0	0	0	0	0	0	0	1												
% Trucks	0.0%	0.0%	0.0%	0.0%	0.0%	0.0%	0.0%	0.0%	0.0%	0.0%	0.0%	0.0%	0.0%	0.0%	0.0%	0.5%	0.0%	0.0%	0.4%	0.0%	0.0%	0.0%	0.0%	0.0%	0.0%	0.0%	0.0%	0.0%	0.2%												
Buses	0	4	1	0	5	0	0	1	0	0	0	1	0	0	7	0	0	7	0	0	0	0	0	2	0	2	0	0	15												
% Buses	0.0%	2.5%	5.6%	0.0%	0.0%	0.0%	0.0%	5.9%	0.0%	0.0%	0.0%	0.0%	0.0%	0.0%	0.0%	3.7%	0.0%	0.0%	0.0%	0.0%	0.0%	0.0%	0.0%	8.0%	0.0%	0.0%	0.0%	2.8%													
Pedestrians	0	0	0	0	0	3	0	0	0	0	0	0	1	0	0	0	0	0	0	10	10	0	0	0	0	0	10	16	0												
% Pedestrians	0.0%	0.0%	0.0%	0.0%	0.0%	100.0%	0.0%	0.0%	0.0%	0.0%	0.0%	0.0%	100.0%	0.0%	0.0%	0.0%	0.0%	0.0%	0.0%	0.0%	100.0%	100.0%	0.0%	0.0%	0.0%	0.0%	0.0%	100.0%	100.0%	0.0%											
Bicycles on Crosswalk	0	0	0	0	0	0	0	0	0	0	0	0	0	0	0	0	0	0	0	0	0	0	0	0	0	0	0	0	0												
% Bicycles on Crosswalk	0.0%	0.0%	0.0%	0.0%	0.0%	0.0%	0.0%	0.0%	0.0%	0.0%	0.0%	0.0%	0.0%	0.0%	0.0%	0.0%	0.0%	0.0%	0.0%	0.0%	0.0%	0.0%	0.0%	0.0%	0.0%	0.0%	0.0%	0.0%	0.0%												

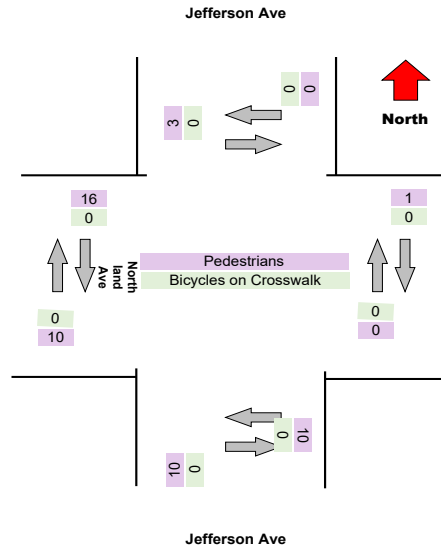
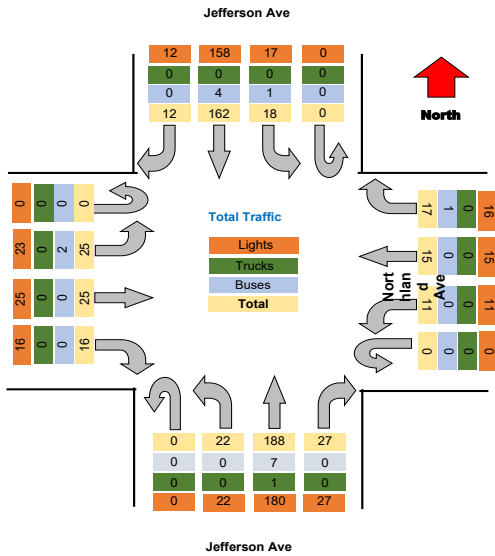



Project : VBH Malta NY  
 Site : Site 4  
 Location : 42.948550, -73.790036  
 Survey Date : 2021-04-28, Wednesday

### Turning Movement Data Plot

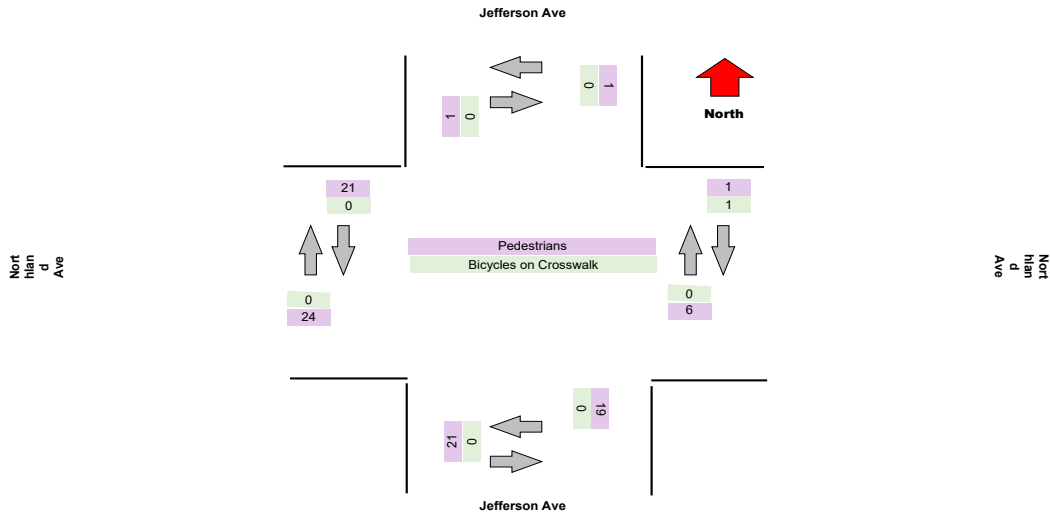
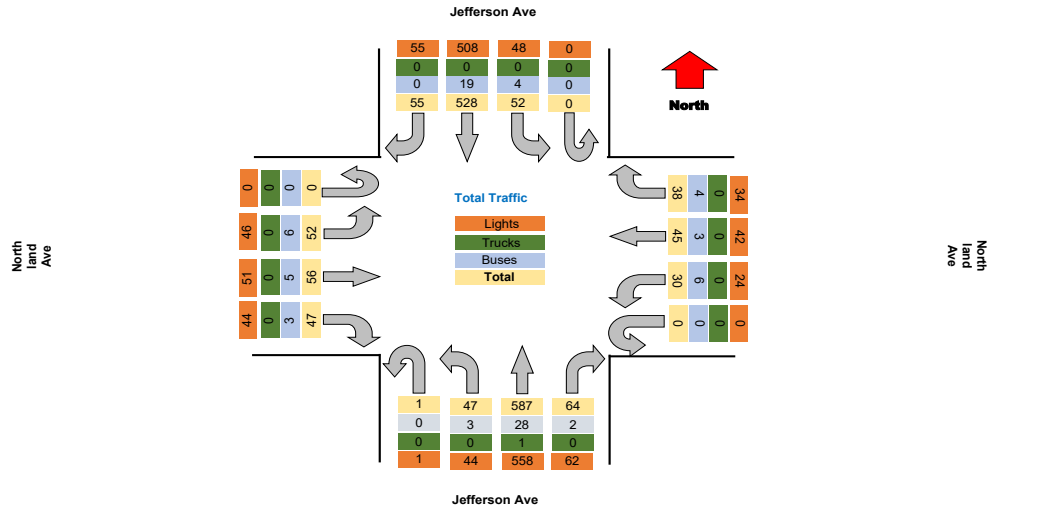



Project : VBH Malta NY  
Site : Site 4  
Location : 42.948550, -73.790036

TSTData.com

Survey Date : 2021-04-28, Wednesday

**Turning Movement Peak Hour Data (AM)**

7:30:00 AM

Leg Direction	Jefferson Ave				Northland Ave				Jefferson Ave				Northland Ave				Total						
	Southbound		Northbound		Westbound		Eastbound		Northbound		Eastbound		Westbound		Eastbound								
Start Time	Right	Thru	Left	U-Turn	App Total	Peds CW	Peds CCW	Right	Thru	Left	U-Turn	App Total	Peds CW	Peds CCW	Right	Thru	Left	U-Turn	App Total	Peds CW	Peds CCW	Total	
7:30:00 AM	5	31	2	0	38	0	0	1	0	1	0	2	0	0	2	30	4	0	36	0	0	84	
7:45:00 AM	6	25	2	0	33	0	1	7	4	2	0	14	0	0	4	30	1	0	35	0	0	91	
8:00:00 AM	3	37	7	0	47	0	0	1	5	0	0	6	0	1	2	38	0	0	41	0	1	105	
8:15:00 AM	5	31	2	0	38	0	0	0	0	1	0	1	0	0	3	40	3	0	46	0	0	99	
<b>Grand Total</b>	<b>19</b>	<b>124</b>	<b>13</b>	<b>0</b>	<b>156</b>	<b>0</b>	<b>1</b>	<b>9</b>	<b>9</b>	<b>4</b>	<b>0</b>	<b>23</b>	<b>0</b>	<b>1</b>	<b>11</b>	<b>138</b>	<b>8</b>	<b>0</b>	<b>158</b>	<b>0</b>	<b>1</b>	<b>379</b>	
% Approach	12.2%	79.5%	8.3%	0.0%	0.0%	0.0%	0.0%	39.1%	39.1%	17.4%	0.0%	0.0%	0.0%	0.0%	7.0%	87.3%	5.1%	0.0%	0.0%	0.0%	0.0%	0.0%	0.0%
% Total	5.0%	32.7%	3.4%	0.0%	41.2%	0.0%	0.0%	2.4%	2.4%	1.1%	0.0%	6.1%	0.0%	0.0%	2.9%	36.4%	2.1%	0.0%	41.7%	0.0%	0.0%	0.0%	0.0%
PHF	0.792	0.838	0.464	0.000	0.830	0.000	0.000	0.321	0.450	0.500	0.000	0.411	0.000	0.000	0.688	0.863	0.500	0.000	0.859	0.000	0.000	0.000	0.902
Lights	19	119	12	0	150	0	0	8	9	3	0	20	0	0	11	126	6	0	143	0	0	350	
% Lights	100.0%	96.0%	92.3%	0.0%	96.2%	0.0%	0.0%	88.9%	100.0%	75.0%	0.0%	87.0%	0.0%	0.0%	100.0%	91.3%	75.0%	0.0%	90.5%	0.0%	0.0%	92.3%	
Trucks	0	0	0	0	0	0	0	0	0	0	0	0	0	0	0	0	0	0	0	0	0	0	0
% Trucks	0.0%	0.0%	0.0%	0.0%	0.0%	0.0%	0.0%	0.0%	0.0%	0.0%	0.0%	0.0%	0.0%	0.0%	0.0%	0.0%	0.0%	0.0%	0.0%	0.0%	0.0%	0.0%	0.0%
Buses	0	5	1	0	6	0	0	1	0	1	0	2	0	0	0	12	2	0	14	0	0	27	
% Buses	0.0%	4.0%	7.7%	0.0%	0.0%	0.0%	0.0%	11.1%	0.0%	25.0%	0.0%	0.0%	0.0%	0.0%	0.0%	8.7%	25.0%	0.0%	0.0%	0.0%	0.0%	0.0%	7.1%
Pedestrians	0	0	0	0	0	0	1	0	0	0	0	0	1	0	0	0	0	0	0	0	1	2	0
% Pedestrians	0.0%	0.0%	0.0%	0.0%	0.0%	0.0%	100.0%	0.0%	0.0%	0.0%	0.0%	0.0%	0.0%	100.0%	0.0%	0.0%	0.0%	0.0%	0.0%	0.0%	0.0%	100.0%	0.0%
Bicycles on Crosswalk	0	0	0	0	0	0	0	0	0	0	0	0	0	0	0	0	0	0	0	0	0	0	0
% Bicycles on Crosswalk	0.0%	0.0%	0.0%	0.0%	0.0%	0.0%	0.0%	0.0%	0.0%	0.0%	0.0%	0.0%	0.0%	0.0%	0.0%	0.0%	0.0%	0.0%	0.0%	0.0%	0.0%	0.0%	0.0%

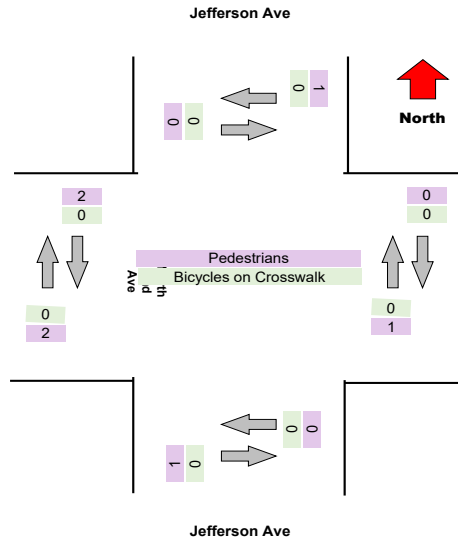
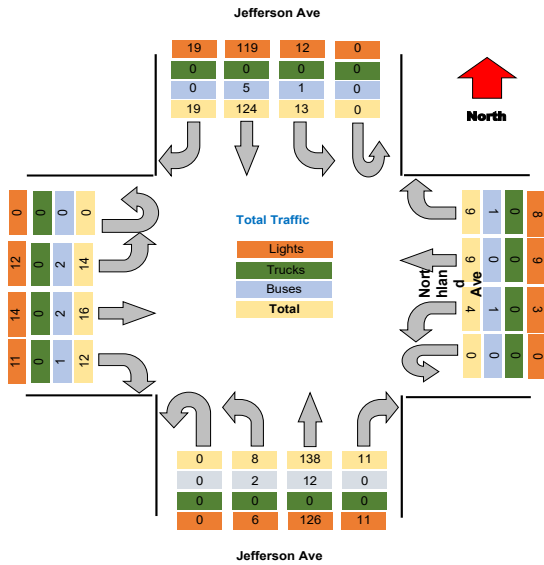

### Turning Movement Peak Hour Data (PM)

5:00:00 PM

Leg Direction	Jefferson Ave								Northland Ave								Jefferson Ave								Northland Ave								Total
	Southbound				Westbound				Northbound				Eastbound				Southbound				Westbound				Northbound				Eastbound				
	Right	Thru	Left	U-Turn	App Total	Peds CW	Peds CCW		Right	Thru	Left	U-Turn	App Total	Peds CW	Peds CCW		Right	Thru	Left	U-Turn	App Total	Peds CW	Peds CCW		Right	Thru	Left	U-Turn	App Total	Peds CW	Peds CCW		
5:00:00 PM	3	47	4	0	54	0	0		3	3	4	0	10	0	0		3	63	3	0	69	1	4		6	5	7	0	18	1	2		151
5:15:00 PM	1	36	5	0	42	0	0		1	6	3	0	10	0	1		4	42	7	0	53	3	2		0	2	5	0	7	2	1		112
5:30:00 PM	3	44	5	0	52	0	0		1	0	1	0	2	0	0		7	50	6	0	63	2	1		2	4	1	0	7	1	2		124
5:45:00 PM	5	39	4	0	47	0	0		4	3	2	0	9	0	0		2	25	7	1	35	0	0		2	4	2	0	8	5	2		99
<b>Grand Total</b>	<b>12</b>	<b>165</b>	<b>18</b>	<b>0</b>	<b>195</b>	<b>0</b>	<b>0</b>		<b>9</b>	<b>12</b>	<b>10</b>	<b>0</b>	<b>31</b>	<b>0</b>	<b>1</b>		<b>16</b>	<b>190</b>	<b>23</b>	<b>1</b>	<b>230</b>	<b>3</b>	<b>7</b>		<b>10</b>	<b>15</b>	<b>15</b>	<b>0</b>	<b>40</b>	<b>3</b>	<b>7</b>		<b>488</b>
% Approach	6.2%	84.6%	9.2%	0.0%	0.0%	0.0%	0.0%		29.0%	38.7%	32.3%	0.0%	0.0%	0.0%	0.0%		7.3%	81.6%	10.5%	0.5%	0.0%	0.0%	0.0%		25.0%	37.5%	37.5%	0.0%	0.0%	0.0%	0.0%		
% Total	2.5%	34.0%	3.7%	0.0%	40.1%	0.0%	0.0%		1.9%	2.5%	2.1%	0.0%	6.4%	0.0%	0.0%		3.3%	37.0%	4.7%	0.2%	45.3%	0.0%	0.0%		2.1%	3.1%	3.1%	0.0%	8.2%	0.0%	0.0%		
PHF	0.600	0.878	0.900	0.000	0.903	0.000	0.000		0.563	0.500	0.625	0.000	0.775	0.000	0.000		0.571	0.714	0.821	0.250	0.787	0.000	0.000		0.417	0.750	0.536	0.000	0.556	0.000	0.000		0.805
Lights	12	162	18	0	192	0	0		9	12	10	0	31	0	0		16	176	23	1	216	0	0		10	15	15	0	40	0	0		479
% Lights	100.0%	98.2%	100.0%	0.0%	98.5%	0.0%	0.0%		100.0%	100.0%	100.0%	0.0%	100.0%	0.0%	0.0%		100.0%	97.8%	100.0%	100.0%	98.2%	0.0%	0.0%		100.0%	100.0%	100.0%	0.0%	100.0%	0.0%	0.0%		98.6%
Trucks	0	0	0	0	0	0	0		0	0	0	0	0	0	0		0	0	0	0	0	0	0		0	0	0	0	0	0	0		0
% Trucks	0.0%	0.0%	0.0%	0.0%	0.0%	0.0%	0.0%		0.0%	0.0%	0.0%	0.0%	0.0%	0.0%	0.0%		0.0%	0.0%	0.0%	0.0%	0.0%	0.0%	0.0%		0.0%	0.0%	0.0%	0.0%	0.0%	0.0%	0.0%		0.0%
Buses	0	3	0	0	3	0	0		0	0	0	0	0	0	0		0	4	0	0	4	0	0		0	0	0	0	0	0	0		7
% Buses	0.0%	1.8%	0.0%	0.0%	0.0%	0.0%	0.0%		0.0%	0.0%	0.0%	0.0%	0.0%	0.0%	0.0%		0.0%	2.2%	0.0%	0.0%	0.0%	0.0%	0.0%		0.0%	0.0%	0.0%	0.0%	0.0%	0.0%	0.0%		1.4%
Pedestrians	0	0	0	0	0	0	0		0	0	0	0	0	1	0		0	0	0	0	0	6	7		0	0	0	0	0	9	7		0
% Pedestrians	0.0%	0.0%	0.0%	0.0%	0.0%	0.0%	0.0%		0.0%	0.0%	0.0%	0.0%	0.0%	0.0%	100.0%		0.0%	0.0%	0.0%	0.0%	0.0%	100.0%	100.0%		0.0%	0.0%	0.0%	0.0%	0.0%	100.0%	100.0%		0.0%
Bicycles on Crosswalk	0	0	0	0	0	0	0		0	0	0	0	0	0	0		0	0	0	0	0	0	0		0	0	0	0	0	0	0		0
% Bicycles on Crosswalk	0.0%	0.0%	0.0%	0.0%	0.0%	0.0%	0.0%		0.0%	0.0%	0.0%	0.0%	0.0%	0.0%	0.0%		0.0%	0.0%	0.0%	0.0%	0.0%	0.0%	0.0%		0.0%	0.0%	0.0%	0.0%	0.0%	0.0%	0.0%		0.0%

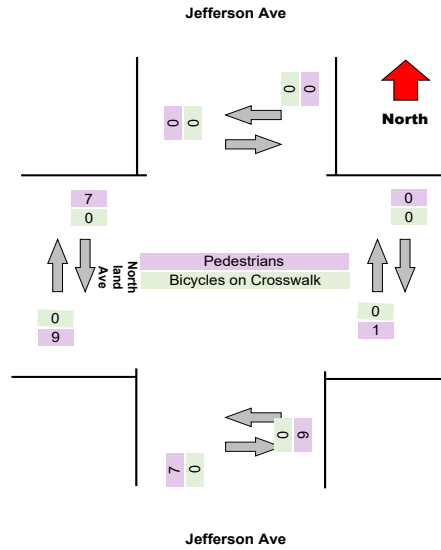
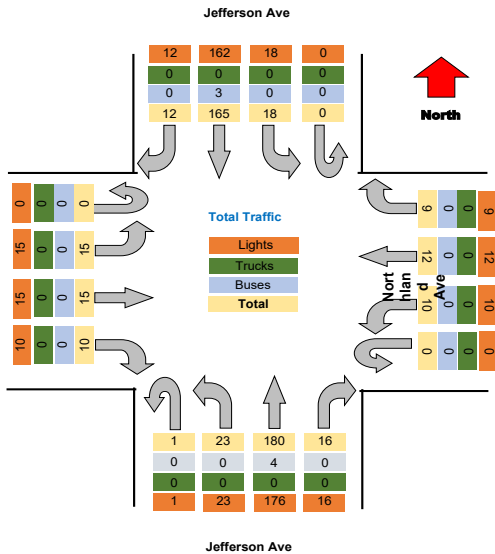



Turning Movement Data Plot

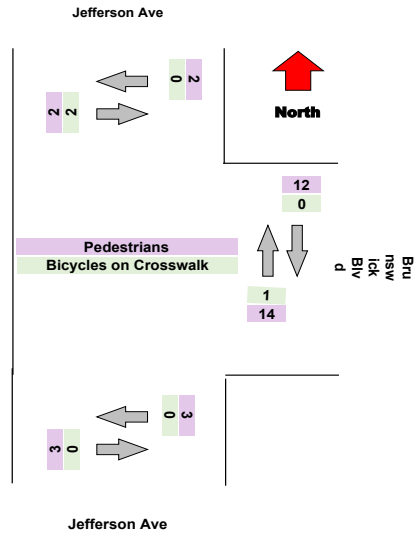
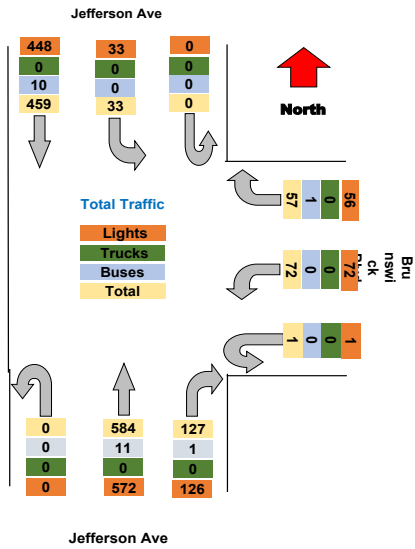

Turning Movement Peak Hour Data (AM)  
 7:30:00 AM

Leg Direction	Jefferson Ave Southbound						Brunswick Blvd Westbound						Jefferson Ave Northbound						Total
	Thru	Left	U-Turn	App Total	Peds CW	Peds CCW	Right	Left	U-Turn	App Total	Peds CW	Peds CCW	Right	Thru	U-Turn	App Total	Peds CW	Peds CCW	
7:30:00 AM	13	1	0	14	0	0	7	4	0	11	1	1	5	19	0	26	0	1	51
7:45:00 AM	22	2	0	24	0	0	1	3	0	4	0	0	6	28	0	34	0	0	62
8:00:00 AM	20	4	0	24	0	0	3	3	0	6	1	1	7	17	0	26	0	0	56
8:15:00 AM	27	1	0	28	0	0	3	7	0	10	0	0	4	13	0	17	0	0	55
<b>Grand Total</b>	82	8	0	90	0	0	14	17	0	31	2	2	22	77	0	103	0	1	224
% Approach	91.1%	8.9%	0.0%	0.0%	0.0%	0.0%	45.2%	54.8%	0.0%	0.0%	0.0%	0.0%	21.4%	74.8%	0.0%	0.0%	0.0%	0.0%	
% Total	36.6%	3.6%	0.0%	40.2%	0.0%	0.0%	6.3%	7.6%	0.0%	13.8%	0.0%	0.0%	9.8%	34.4%	0.0%	46.0%	0.0%	0.0%	
PHF	0.759	0.500	0.000	0.804	0.000	0.000	0.500	0.607	0.000	0.705	0.000	0.000	0.786	0.688	0.000	0.757	0.000	0.000	0.903
Lights	80	8	0	88	0	0	13	17	0	30	0	0	21	74	0	95	0	0	213
% Lights	97.6%	100.0%	0.0%	97.8%	0.0%	0.0%	92.9%	100.0%	0.0%	96.8%	0.0%	0.0%	95.5%	96.1%	0.0%	92.2%	0.0%	0.0%	95.1%
Trucks	0	0	0	0	0	0	0	0	0	0	0	0	0	0	0	0	0	0	0
% Trucks	0.0%	0.0%	0.0%	0.0%	0.0%	0.0%	0.0%	0.0%	0.0%	0.0%	0.0%	0.0%	0.0%	0.0%	0.0%	0.0%	0.0%	0.0%	0.0%
Buses	2	0	0	2	0	0	1	0	0	1	0	0	1	3	0	4	0	0	7
% Buses	2.4%	0.0%	0.0%	0.0%	0.0%	0.0%	7.1%	0.0%	0.0%	0.0%	0.0%	0.0%	4.5%	3.9%	0.0%	0.0%	0.0%	0.0%	3.1%
Pedestrians	0	0	0	0	0	0	0	0	0	2	2	0	0	0	0	0	0	1	0
% Pedestrians	0.0%	0.0%	0.0%	0.0%	0.0%	0.0%	0.0%	0.0%	0.0%	0.0%	100.0%	100.0%	0.0%	0.0%	0.0%	0.0%	0.0%	100.0%	0.0%
Bicycles on Crosswalk	0	0	0	0	0	0	0	0	0	0	0	0	0	0	0	0	0	0	0
% Bicycles on Crosswalk	0.0%	0.0%	0.0%	0.0%	0.0%	0.0%	0.0%	0.0%	0.0%	0.0%	0.0%	0.0%	0.0%	0.0%	0.0%	0.0%	0.0%	0.0%	0.0%

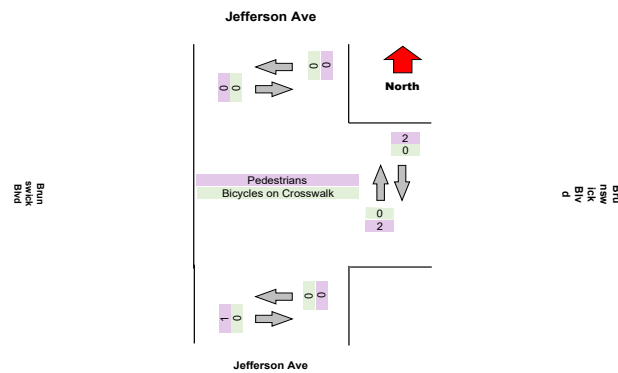
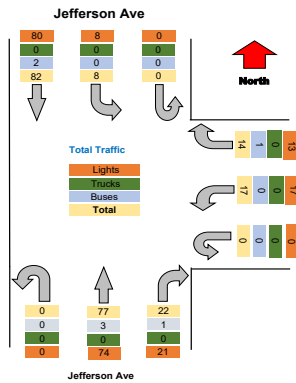

Turning Movement Peak Hour Data (PM)  
 5:00:00 PM

Leg Direction	Jefferson Ave Southbound						Brunswick Blvd Westbound						Jefferson Ave Northbound						Total
	Thru	Left	U-Turn	App Total	Peds CW	Peds CCW	Right	Left	U-Turn	App Total	Peds CW	Peds CCW	Right	Thru	U-Turn	App Total	Peds CW	Peds CCW	
5:00:00 PM	39	6	0	45	0	0	5	7	0	12	0	0	18	56	0	74	0	1	131
5:15:00 PM	41	2	0	43	0	0	3	5	0	8	0	0	5	51	0	56	1	0	107
5:30:00 PM	35	3	0	38	0	0	6	7	0	13	2	3	17	49	0	66	0	0	117
5:45:00 PM	28	0	0	28	0	0	1	5	0	6	0	1	11	45	0	56	0	0	90
<b>Grand Total</b>	143	11	0	154	0	0	15	24	0	39	2	4	51	201	0	252	1	1	445
% Approach	92.9%	7.1%	0.0%	0.0%	0.0%	0.0%	38.5%	61.5%	0.0%	0.0%	0.0%	0.0%	20.2%	79.8%	0.0%	0.0%	0.0%	0.0%	
% Total	32.1%	2.5%	0.0%	34.6%	0.0%	0.0%	3.4%	5.4%	0.0%	8.8%	0.0%	0.0%	11.5%	45.2%	0.0%	56.6%	0.0%	0.0%	
PHF	0.872	0.458	0.000	0.856	0.000	0.000	0.625	0.857	0.000	0.750	0.000	0.000	0.708	0.897	0.000	0.851	0.000	0.000	0.849
Lights	141	11	0	152	0	0	15	24	0	39	0	0	51	199	0	250	0	0	441
% Lights	98.6%	100.0%	0.0%	98.7%	0.0%	0.0%	100.0%	100.0%	0.0%	100.0%	0.0%	0.0%	100.0%	99.0%	0.0%	99.2%	0.0%	0.0%	99.1%
Trucks	0	0	0	0	0	0	0	0	0	0	0	0	0	0	0	0	0	0	0
% Trucks	0.0%	0.0%	0.0%	0.0%	0.0%	0.0%	0.0%	0.0%	0.0%	0.0%	0.0%	0.0%	0.0%	0.0%	0.0%	0.0%	0.0%	0.0%	0.0%
Buses	2	0	0	2	0	0	0	0	0	0	0	0	0	0	0	2	0	0	4
% Buses	1.4%	0.0%	0.0%	0.0%	0.0%	0.0%	0.0%	0.0%	0.0%	0.0%	0.0%	0.0%	0.0%	1.0%	0.0%	0.0%	0.0%	0.0%	0.9%
Pedestrians	0	0	0	0	0	0	0	0	0	0	2	4	0	0	0	0	1	1	0
% Pedestrians	0.0%	0.0%	0.0%	0.0%	0.0%	0.0%	0.0%	0.0%	0.0%	0.0%	100.0%	100.0%	0.0%	0.0%	0.0%	0.0%	100.0%	100.0%	0.0%
Bicycles on Crosswalk	0	0	0	0	0	0	0	0	0	0	0	0	0	0	0	0	0	0	0
% Bicycles on Crosswalk	0.0%	0.0%	0.0%	0.0%	0.0%	0.0%	0.0%	0.0%	0.0%	0.0%	0.0%	0.0%	0.0%	0.0%	0.0%	0.0%	0.0%	0.0%	0.0%

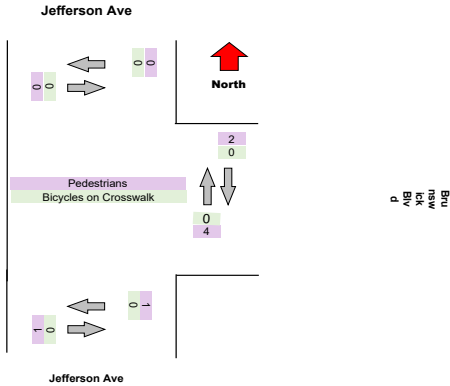
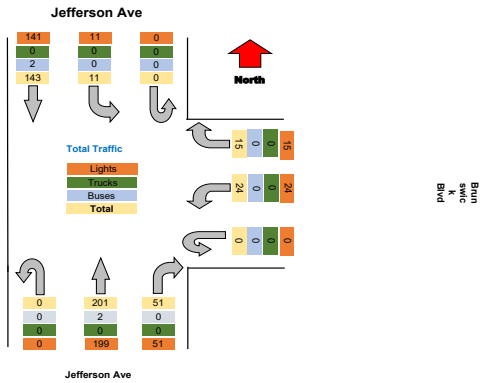



Turning Movement Data Plot

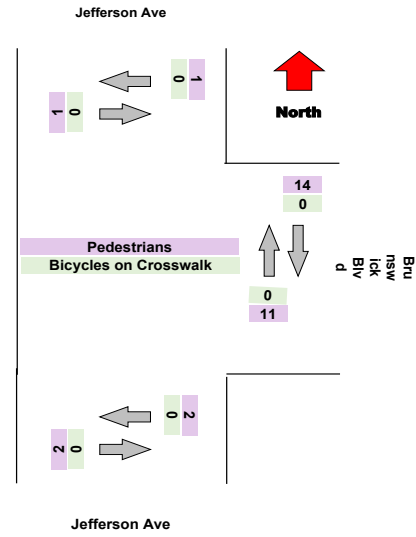
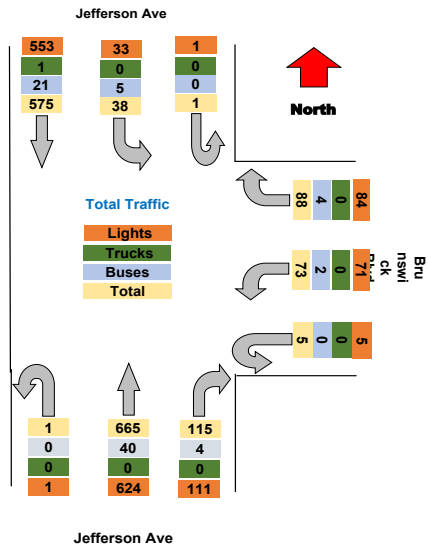



Turning Movement Peak Hour Data (AM)  
 7:30:00 AM

Leg Direction	Jefferson Ave Southbound						Brunswick Blvd Westbound						Jefferson Ave Northbound						Total
	Thru	Left	U-Turn	App Total	Peds CW	Peds CCW	Right	Left	U-Turn	App Total	Peds CW	Peds CCW	Right	Thru	U-Turn	App Total	Peds CW	Peds CCW	
7:30:00 AM	24	1	0	25	0	0	6	6	0	12	0	2	4	29	0	35	0	1	
7:45:00 AM	51	4	0	55	0	1	4	6	1	12	2	0	8	21	0	31	0	0	
8:00:00 AM	28	2	0	30	0	0	4	7	0	11	0	1	7	41	0	49	0	1	
8:15:00 AM	27	1	0	28	0	0	4	4	0	8	1	0	2	41	0	44	0	0	
<b>Grand Total</b>	130	8	0	138	0	1	18	23	1	43	3	3	21	132	0	159	0	2	
% Approach	94.2%	5.8%	0.0%	0.0%	0.0%	0.0%	41.9%	53.5%	2.3%	0.0%	0.0%	0.0%	13.2%	83.0%	0.0%	0.0%	0.0%	0.0%	
% Total	38.2%	2.4%	0.0%	40.6%	0.0%	0.0%	5.3%	6.8%	0.3%	12.6%	0.0%	0.0%	6.2%	38.8%	0.0%	46.8%	0.0%	0.0%	
PHF	0.637	0.500	0.000	0.627	0.000	0.000	0.750	0.821	0.250	0.896	0.000	0.000	0.656	0.805	0.000	0.811	0.000	0.000	
Lights	124	7	0	131	0	0	16	22	1	39	0	0	20	120	0	140	0	0	
% Lights	95.4%	87.5%	0.0%	94.9%	0.0%	0.0%	88.9%	95.7%	100.0%	90.7%	0.0%	0.0%	95.2%	90.9%	0.0%	88.1%	0.0%	0.0%	
Trucks	0	0	0	0	0	0	0	0	0	0	0	0	0	0	0	0	0	0	
% Trucks	0.0%	0.0%	0.0%	0.0%	0.0%	0.0%	0.0%	0.0%	0.0%	0.0%	0.0%	0.0%	0.0%	0.0%	0.0%	0.0%	0.0%	0.0%	
Buses	6	1	0	7	0	0	2	1	0	3	0	0	1	12	0	13	0	0	
% Buses	4.6%	12.5%	0.0%	0.0%	0.0%	0.0%	11.1%	4.3%	0.0%	0.0%	0.0%	0.0%	4.8%	9.1%	0.0%	0.0%	0.0%	0.0%	
Pedestrians	0	0	0	0	0	1	0	0	0	0	3	3	0	0	0	0	0	2	
% Pedestrians	0.0%	0.0%	0.0%	0.0%	0.0%	100.0%	0.0%	0.0%	0.0%	0.0%	100.0%	100.0%	0.0%	0.0%	0.0%	0.0%	0.0%	100.0%	
Bicycles on Crosswalk	0	0	0	0	0	0	0	0	0	0	0	0	0	0	0	0	0	0	
% Bicycles on Crosswalk	0.0%	0.0%	0.0%	0.0%	0.0%	0.0%	0.0%	0.0%	0.0%	0.0%	0.0%	0.0%	0.0%	0.0%	0.0%	0.0%	0.0%	0.0%	

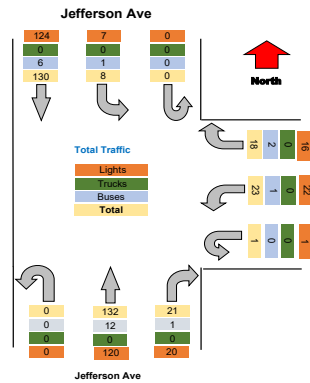

Brunswick Blvd

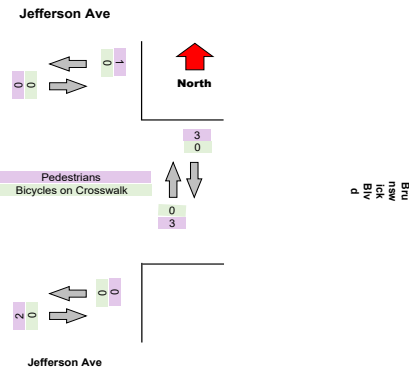

Brunswick Blvd

Turning Movement Peak Hour Data (PM)

5:00:00 PM

Leg Direction	Jefferson Ave Southbound						Brunswick Blvd Westbound						Jefferson Ave Northbound						Total
	Thru	Left	U-Turn	App Total	Peds CW	Peds CCW	Right	Left	U-Turn	App Total	Peds CW	Peds CCW	Right	Thru	U-Turn	App Total	Peds CW	Peds CCW	
5:00:00 PM	43	2	0	45	0	0	7	6	0	13	0	0	11	61	0	72	0	0	130
5:15:00 PM	41	1	0	42	1	0	3	8	0	11	0	0	10	64	0	74	0	0	127
5:30:00 PM	47	2	0	49	0	0	7	5	1	13	0	0	5	58	0	63	0	0	125
5:45:00 PM	38	3	0	41	0	0	6	4	0	10	0	1	13	45	1	59	1	0	110
<b>Grand Total</b>	169	8	0	177	1	0	23	23	1	47	0	1	39	228	1	268	1	0	492
% Approach	95.5%	4.5%	0.0%	0.0%	0.0%	0.0%	48.9%	48.9%	2.1%	0.0%	0.0%	0.0%	14.6%	85.1%	0.4%	0.0%	0.0%	0.0%	
% Total	34.3%	1.6%	0.0%	36.0%	0.0%	0.0%	4.7%	4.7%	0.2%	9.6%	0.0%	0.0%	7.9%	46.3%	0.2%	54.5%	0.0%	0.0%	
PHF	0.899	0.667	0.000	0.903	0.000	0.000	0.821	0.719	0.250	0.904	0.000	0.000	0.750	0.891	0.250	0.905	0.000	0.000	0.946
Lights	166	8	0	174	0	0	23	22	1	46	0	0	38	219	1	258	0	0	478
% Lights	98.2%	100.0%	0.0%	98.3%	0.0%	0.0%	100.0%	95.7%	100.0%	97.9%	0.0%	0.0%	97.4%	96.1%	100.0%	96.3%	0.0%	0.0%	97.2%
Trucks	0	0	0	0	0	0	0	0	0	0	0	0	0	0	0	0	0	0	0
% Trucks	0.0%	0.0%	0.0%	0.0%	0.0%	0.0%	0.0%	0.0%	0.0%	0.0%	0.0%	0.0%	0.0%	0.0%	0.0%	0.0%	0.0%	0.0%	0.0%
Buses	3	0	0	3	0	0	0	1	0	1	0	0	0	9	0	10	0	0	14
% Buses	1.8%	0.0%	0.0%	0.0%	0.0%	0.0%	0.0%	4.3%	0.0%	0.0%	0.0%	0.0%	2.6%	3.9%	0.0%	0.0%	0.0%	0.0%	2.8%
Pedestrians	0	0	0	0	1	0	0	0	0	0	1	0	0	0	0	1	0	0	0
% Pedestrians	0.0%	0.0%	0.0%	0.0%	100.0%	0.0%	0.0%	0.0%	0.0%	0.0%	100.0%	0.0%	0.0%	0.0%	0.0%	0.0%	100.0%	0.0%	0.0%
Bicycles on Crosswalk	0	0	0	0	0	0	0	0	0	0	0	0	0	0	0	0	0	0	0
% Bicycles on Crosswalk	0.0%	0.0%	0.0%	0.0%	0.0%	0.0%	0.0%	0.0%	0.0%	0.0%	0.0%	0.0%	0.0%	0.0%	0.0%	0.0%	0.0%	0.0%	0.0%

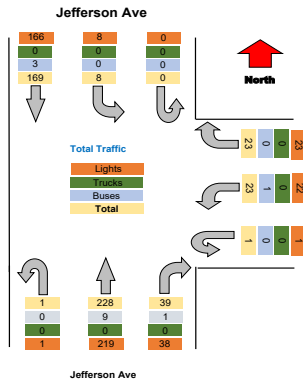

Brunswick Blvd

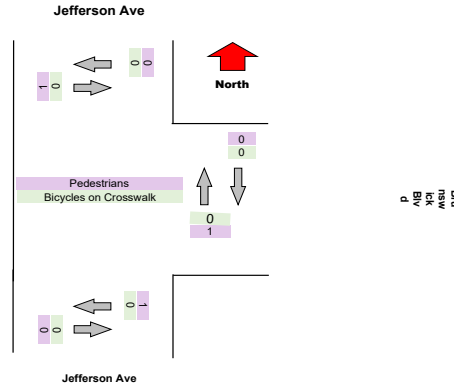

Brunswick Blvd



Turning Movement Data Plot

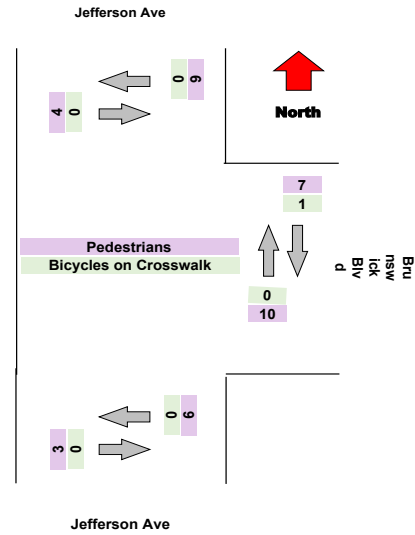
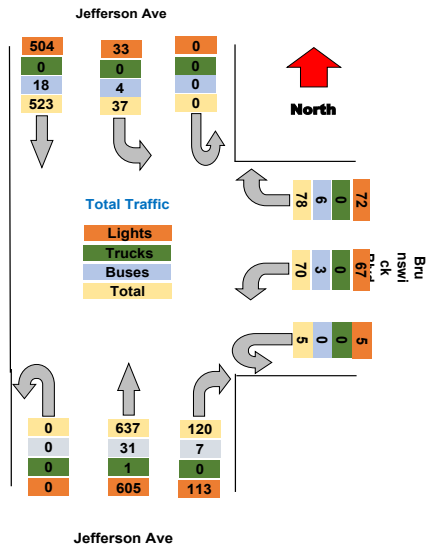

Turning Movement Peak Hour Data (AM)

7:30:00 AM

Leg Direction	Jefferson Ave Southbound						Brunswick Blvd Westbound						Jefferson Ave Northbound						Total
	Thru	Left	U-Turn	App Total	Peds CW	Peds CCW	Right	Left	U-Turn	App Total	Peds CW	Peds CCW	Right	Thru	U-Turn	App Total	Peds CW	Peds CCW	
7:30:00 AM	32	2	0	34	0	0	8	7	0	15	0	0	0	28	0	28	0	0	77
7:45:00 AM	29	1	0	30	0	1	5	7	0	13	0	0	3	34	0	37	0	0	80
8:00:00 AM	38	2	0	40	0	0	4	4	1	9	1	1	11	37	0	50	0	0	99
8:15:00 AM	31	2	0	33	0	0	7	3	1	11	0	0	6	41	0	47	0	0	91
<b>Grand Total</b>	130	7	0	137	0	1	24	21	2	48	1	1	20	140	0	162	0	0	347
% Approach	94.9%	5.1%	0.0%	0.0%	0.0%	0.0%	50.0%	43.8%	4.2%	0.0%	0.0%	0.0%	12.3%	86.4%	0.0%	0.0%	0.0%	0.0%	
% Total	37.5%	2.0%	0.0%	39.5%	0.0%	0.0%	6.9%	6.1%	0.6%	13.8%	0.0%	0.0%	5.8%	40.3%	0.0%	46.7%	0.0%	0.0%	
PHF	0.855	0.875	0.000	0.856	0.000	0.000	0.750	0.750	0.500	0.800	0.000	0.000	0.455	0.854	0.000	0.810	0.000	0.000	0.876
Lights	125	6	0	131	0	0	20	20	2	42	0	0	18	128	0	146	0	0	319
% Lights	96.2%	85.7%	0.0%	95.6%	0.0%	0.0%	83.3%	95.2%	100.0%	87.5%	0.0%	0.0%	90.0%	91.4%	0.0%	90.1%	0.0%	0.0%	91.9%
Trucks	0	0	0	0	0	0	0	0	0	0	0	0	0	0	0	0	0	0	0
% Trucks	0.0%	0.0%	0.0%	0.0%	0.0%	0.0%	0.0%	0.0%	0.0%	0.0%	0.0%	0.0%	0.0%	0.0%	0.0%	0.0%	0.0%	0.0%	0.0%
Buses	5	1	0	6	0	0	4	1	0	5	0	0	2	12	0	14	0	0	25
% Buses	3.8%	14.3%	0.0%	0.0%	0.0%	0.0%	16.7%	4.8%	0.0%	0.0%	0.0%	0.0%	10.0%	8.6%	0.0%	0.0%	0.0%	0.0%	7.2%
Pedestrians	0	0	0	0	0	1	0	0	0	0	1	1	0	0	0	0	0	0	0
% Pedestrians	0.0%	0.0%	0.0%	0.0%	0.0%	100.0%	0.0%	0.0%	0.0%	0.0%	100.0%	100.0%	0.0%	0.0%	0.0%	0.0%	0.0%	0.0%	0.0%
Bicycles on Crosswalk	0	0	0	0	0	0	0	0	0	0	0	0	0	0	0	0	0	0	0
% Bicycles on Crosswalk	0.0%	0.0%	0.0%	0.0%	0.0%	0.0%	0.0%	0.0%	0.0%	0.0%	0.0%	0.0%	0.0%	0.0%	0.0%	0.0%	0.0%	0.0%	0.0%



Brunswick Blvd

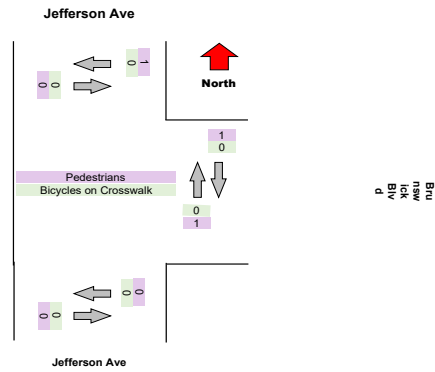

Brunswick Blvd

**Turning Movement Peak Hour Data (PM)**  
 5:00:00 PM

Leg Direction	Jefferson Ave Southbound						Brunswick Blvd Westbound						Jefferson Ave Northbound						Total
	Thru	Left	U-Turn	App Total	Peds CW	Peds CCW	Right	Left	U-Turn	App Total	Peds CW	Peds CCW	Right	Thru	U-Turn	App Total	Peds CW	Peds CCW	
5:00:00 PM	49	2	0	51	1	2	7	5	0	12	0	1	16	63	0	79	4	3	142
5:15:00 PM	30	2	0	32	0	0	4	2	0	6	1	0	6	50	0	56	0	0	94
5:30:00 PM	47	3	0	50	0	3	8	4	1	13	2	2	13	59	0	72	0	0	135
5:45:00 PM	32	4	0	36	2	0	8	4	0	12	0	1	9	31	0	40	1	0	88
<b>Grand Total</b>	158	11	0	169	3	5	27	15	1	43	3	4	44	203	0	247	5	3	459
% Approach	93.5%	6.5%	0.0%	0.0%	0.0%	0.0%	62.8%	34.9%	2.3%	0.0%	0.0%	0.0%	17.8%	82.2%	0.0%	0.0%	0.0%	0.0%	0.0%
% Total	34.4%	2.4%	0.0%	36.8%	0.0%	0.0%	5.9%	3.3%	0.2%	9.4%	0.0%	0.0%	9.6%	44.2%	0.0%	53.8%	0.0%	0.0%	0.0%
PHF	0.806	0.688	0.000	0.828	0.000	0.000	0.844	0.750	0.250	0.827	0.000	0.000	0.688	0.806	0.000	0.782	0.000	0.000	0.808
Lights	155	11	0	166	0	0	27	15	1	43	0	0	43	198	0	241	0	0	450
% Lights	98.1%	100.0%	0.0%	98.2%	0.0%	0.0%	100.0%	100.0%	100.0%	100.0%	0.0%	0.0%	97.7%	97.5%	0.0%	97.6%	0.0%	0.0%	98.0%
Trucks	0	0	0	0	0	0	0	0	0	0	0	0	0	0	0	0	0	0	0
% Trucks	0.0%	0.0%	0.0%	0.0%	0.0%	0.0%	0.0%	0.0%	0.0%	0.0%	0.0%	0.0%	0.0%	0.0%	0.0%	0.0%	0.0%	0.0%	0.0%
Buses	3	0	0	3	0	0	0	0	0	0	0	0	1	5	0	6	0	0	9
% Buses	1.9%	0.0%	0.0%	0.0%	0.0%	0.0%	0.0%	0.0%	0.0%	0.0%	0.0%	0.0%	2.3%	2.5%	0.0%	0.0%	0.0%	0.0%	2.0%
Pedestrians	0	0	0	0	3	5	0	0	0	0	3	4	0	0	0	0	5	3	0
% Pedestrians	0.0%	0.0%	0.0%	0.0%	100.0%	100.0%	0.0%	0.0%	0.0%	0.0%	100.0%	100.0%	0.0%	0.0%	0.0%	0.0%	100.0%	100.0%	0.0%
Bicycles on Crosswalk	0	0	0	0	0	0	0	0	0	0	0	0	0	0	0	0	0	0	0
% Bicycles on Crosswalk	0.0%	0.0%	0.0%	0.0%	0.0%	0.0%	0.0%	0.0%	0.0%	0.0%	0.0%	0.0%	0.0%	0.0%	0.0%	0.0%	0.0%	0.0%	0.0%

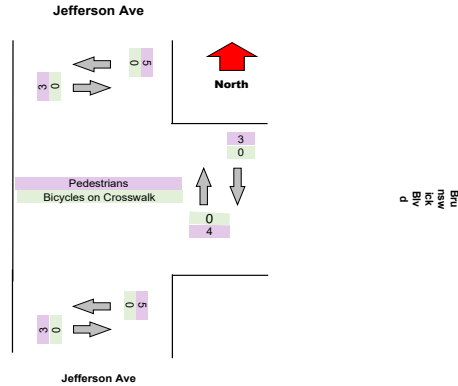
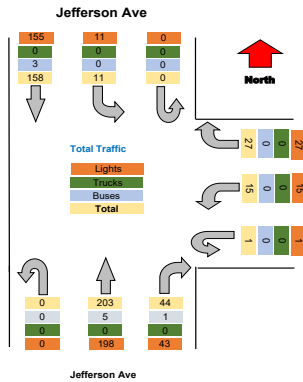

Project : VBH Malta NY  
 Site : Site 4  
 Location : 42.948550, -73.790036

TSTData.com

Survey Date : 2021-04-28, Wednesday

Project	LaBella
Project Code	LaBella
Site Name	32
Legs and Movements	All Processed Legs & Move
Bin Size	15 minutes
Survey Date	2021-11-02, Tuesday
Location	32
Latitude and Longitude	42.914969, -78.853981

	Start	End	PHF
Forced Peak AM	2021/11/02 07:30:00	2021/11/02 08:30:00	0.85
Forced Peak PM	2021/11/02 16:30:00	2021/11/02 17:30:00	0.96
AM Peak	2021/11/02 07:30:00	2021/11/02 08:30:00	0.85
PM Peak	2021/11/02 16:15:00	2021/11/02 17:15:00	0.95

### Turning Movement Data

Leg Direction	Jefferson Ave Southbound					East Ferry St Westbound					Jefferson Ave Northbound					East Ferry St Eastbound					Total
	Right	Thru	Left	U-Turn	App Total	Right	Thru	Left	U-Turn	App Total	Right	Thru	Left	U-Turn	App Total	Right	Thru	Left	U-Turn	App Total	
6:30:00 AM	2	7	4	0	13	7	50	8	0	67	1	11	6	0	18	4	28	1	0	33	131
6:45:00 AM	2	12	3	0	17	6	52	2	0	60	2	13	8	0	23	5	20	3	0	29	129
Hourly Total	4	19	7	0	30	13	102	10	0	127	3	24	14	0	41	9	48	4	0	62	260
7:00:00 AM	2	9	4	0	15	8	37	4	0	49	3	30	4	0	37	2	21	3	0	26	127
7:15:00 AM	3	14	1	0	18	8	49	7	0	66	3	19	7	0	29	3	18	2	0	23	136
7:30:00 AM	1	14	5	0	20	6	64	3	0	73	5	18	5	0	30	6	24	1	0	31	164
7:45:00 AM	5	15	3	0	23	9	104	10	0	125	2	22	4	0	29	3	33	3	0	39	216
Hourly Total	11	52	13	0	76	31	254	24	0	313	13	89	20	0	125	14	96	9	0	119	633
8:00:00 AM	2	18	3	0	23	7	90	5	0	107	5	17	2	0	26	2	29	2	0	33	188
8:15:00 AM	2	30	3	0	35	9	70	7	0	87	6	9	7	0	23	7	27	0	0	34	179
Hourly Total	4	48	6	0	58	16	160	12	0	194	11	26	9	0	48	9	56	2	0	67	367
4:00:00 PM	8	31	10	0	49	13	83	11	0	107	22	38	16	0	76	17	52	8	0	77	309
4:15:00 PM	5	33	5	0	43	10	93	13	0	116	16	47	13	0	76	12	47	9	0	68	303
4:30:00 PM	6	46	6	0	58	13	85	9	0	107	22	46	13	0	81	18	47	7	0	72	318
4:45:00 PM	3	35	7	0	45	5	97	13	0	115	8	43	13	0	64	7	50	12	0	69	293
Hourly Total	22	145	28	0	195	41	358	46	0	445	68	174	55	0	297	54	196	36	0	286	1223
5:00:00 PM	11	31	11	0	53	17	78	9	0	102	19	43	8	0	69	18	45	11	0	74	298
5:15:00 PM	4	38	12	0	54	23	97	18	0	138	16	37	11	0	64	8	45	2	0	55	311
5:30:00 PM	5	33	5	0	43	9	81	12	0	102	9	49	7	0	65	12	38	5	0	55	265
5:45:00 PM	3	31	10	0	44	13	81	13	0	107	17	44	11	0	72	9	23	4	0	36	259
Hourly Total	23	133	38	0	194	62	335	52	0	449	60	173	37	0	270	47	151	22	0	220	1133
Grand Total	64	397	92	0	553	163	1209	144	0	1528	155	486	135	0	781	134	547	73	0	754	3616
% Approach	11.6%	71.8%	16.6%	0.0%	0.0%	10.7%	79.1%	9.4%	0.0%	0.0%	19.8%	62.2%	17.3%	0.0%	0.0%	17.8%	72.5%	9.7%	0.0%	0.0%	0.0%
% Total	1.8%	11.0%	2.5%	0.0%	15.3%	4.5%	33.4%	4.0%	0.0%	42.3%	4.3%	13.4%	3.7%	0.0%	21.6%	3.7%	15.1%	2.0%	0.0%	20.9%	0.0%
Lights	63	386	92	0	541	162	1183	140	0	1485	155	474	134	0	763	133	535	73	0	741	3530
% Lights	98.4%	97.2%	100.0%	0.0%	97.8%	99.4%	97.6%	97.2%	0.0%	97.2%	100.0%	97.5%	99.3%	0.0%	97.7%	99.3%	97.8%	100.0%	0.0%	98.3%	97.6%
Trucks	0	0	0	0	0	0	0	2	0	2	0	0	0	0	0	0	0	0	0	0	2
% Trucks	0.0%	0.0%	0.0%	0.0%	0.0%	0.0%	0.0%	1.4%	0.0%	0.1%	0.0%	0.0%	0.0%	0.0%	0.0%	0.0%	0.0%	0.0%	0.0%	0.0%	0.1%
Buses	1	9	0	0	10	1	25	2	0	28	0	11	1	0	12	1	11	0	0	12	62
% Buses	1.6%	2.3%	0.0%	0.0%	0.0%	0.0%	2.1%	1.4%	0.0%	0.0%	0.0%	2.3%	0.7%	0.0%	0.0%	0.7%	2.0%	0.0%	0.0%	0.0%	1.7%
Pedestrians	0	0	0	0	0	0	0	0	0	0	0	0	0	0	0	0	0	0	0	0	0
% Pedestrians	0.0%	0.0%	0.0%	0.0%	0.0%	0.0%	0.0%	0.0%	0.0%	0.0%	0.0%	0.0%	0.0%	0.0%	0.0%	0.0%	0.0%	0.0%	0.0%	0.0%	0.0%
Bicycles on Crosswalk	0	0	0	0	0	0	0	0	0	0	0	0	0	0	0	0	0	0	0	0	0
% Bicycles on Crosswalk	0.0%	0.0%	0.0%	0.0%	0.0%	0.0%	0.0%	0.0%	0.0%	0.0%	0.0%	0.0%	0.0%	0.0%	0.0%	0.0%	0.0%	0.0%	0.0%	0.0%	0.0%

Project : VBH Malta NY  
 Site : Site 4  
 Location : 42.948550, -73.790036  
 Survey Date : 2021-04-28, Wednesday

### Turning Movement Data Plot

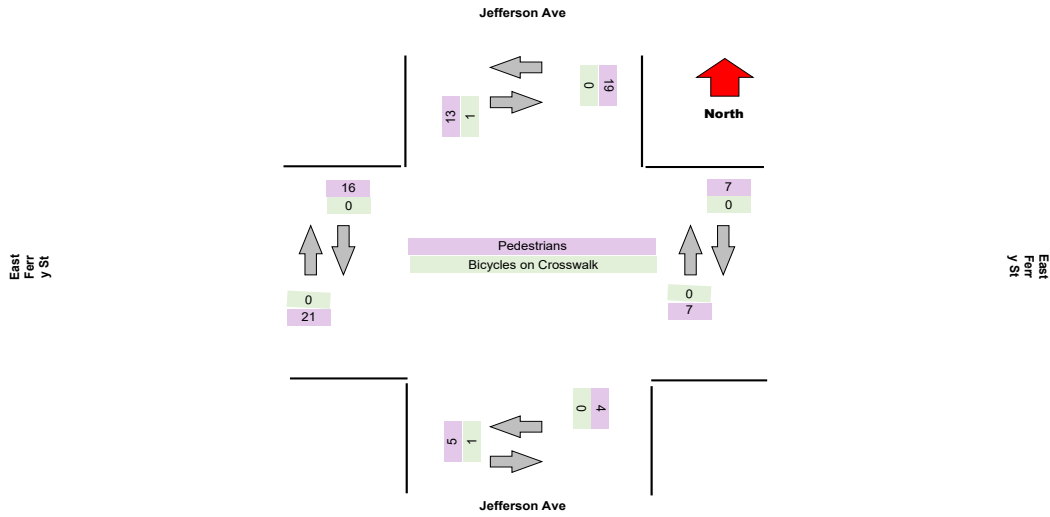
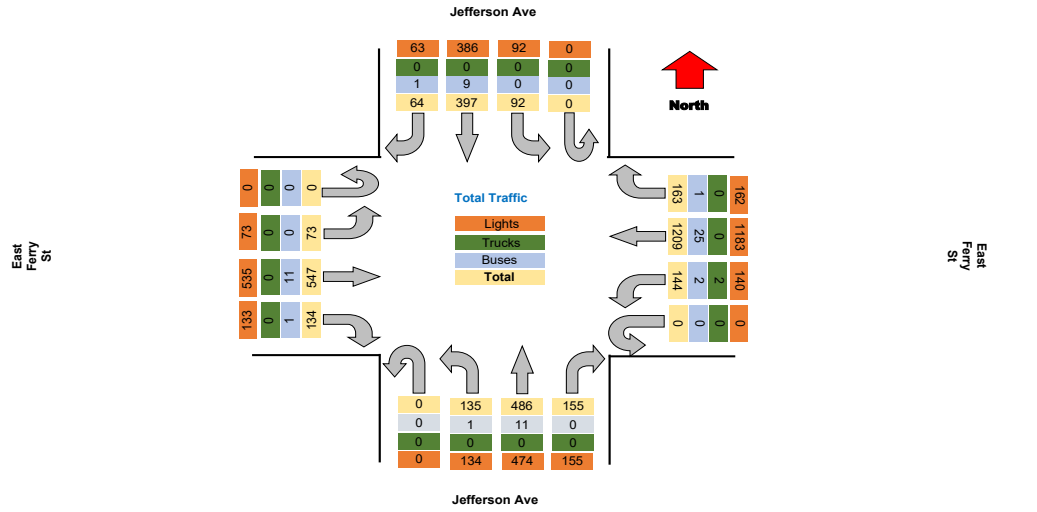



Project : VBH Malta NY  
Site : Site 4  
Location : 42.948550, -73.790036

TSTData.com

Survey Date : 2021-04-28, Wednesday

**Turning Movement Peak Hour Data (AM)**

7:30:00 AM

Leg Direction	Jefferson Ave				East Ferry St				Jefferson Ave				East Ferry St				Total				
	Southbound		Northbound		Westbound		Eastbound		Northbound		Southbound		Eastbound								
Start Time	Right	Thru	Left	U-Turn	App Total	Peds CW	Peds CCW	Right	Thru	Left	U-Turn	App Total	Peds CW	Peds CCW	Right	Thru	Left	U-Turn	App Total	Peds CW	Peds CCW
7:30:00 AM	1	14	5	0	20	1	0	6	64	3	0	73	2	0	5	18	5	0	30	1	1
7:45:00 AM	5	15	3	0	23	1	2	9	104	10	0	125	0	1	2	22	4	0	29	1	1
8:00:00 AM	2	18	3	0	23	3	5	7	90	5	0	107	0	1	5	17	2	0	25	0	0
8:15:00 AM	2	30	3	0	35	1	1	9	70	7	0	87	0	1	6	9	7	0	23	0	1
<b>Grand Total</b>	10	77	14	0	101	6	8	31	328	25	0	392	2	3	18	66	18	0	107	2	3
% Approach	9.9%	76.2%	13.9%	0.0%	0.0%	0.0%	0.0%	7.9%	83.7%	6.4%	0.0%	0.0%	0.0%	0.0%	16.8%	61.7%	16.8%	0.0%	0.0%	0.0%	0.0%
% Total	1.4%	10.4%	1.9%	0.0%	13.7%	0.0%	0.0%	4.2%	44.5%	3.4%	0.0%	53.2%	0.0%	0.0%	2.4%	9.0%	2.4%	0.0%	14.5%	0.0%	0.0%
PHF	0.500	0.642	0.700	0.000	0.721	0.000	0.000	0.861	0.788	0.625	0.000	0.784	0.000	0.000	0.750	0.750	0.643	0.000	0.892	0.000	0.000
Lights	10	74	14	0	98	0	8	31	321	24	0	376	0	0	18	62	18	0	98	0	0
% Lights	100.0%	96.1%	100.0%	0.0%	97.0%	0.0%	0.0%	100.0%	97.9%	96.0%	0.0%	95.9%	0.0%	0.0%	100.0%	93.9%	100.0%	0.0%	91.6%	0.0%	0.0%
Trucks	0	0	0	0	0	0	0	0	0	1	0	1	0	0	0	0	0	0	0	0	0
% Trucks	0.0%	0.0%	0.0%	0.0%	0.0%	0.0%	0.0%	0.0%	0.0%	4.0%	0.0%	0.3%	0.0%	0.0%	0.0%	0.0%	0.0%	0.0%	0.0%	0.0%	0.0%
Buses	0	2	0	0	2	0	0	0	6	0	0	6	0	0	0	4	0	0	4	0	0
% Buses	0.0%	2.6%	0.0%	0.0%	0.0%	0.0%	0.0%	0.0%	1.8%	0.0%	0.0%	0.0%	0.0%	0.0%	0.0%	6.1%	0.0%	0.0%	0.0%	0.0%	0.0%
Pedestrians	0	0	0	0	0	6	5	0	0	0	0	2	3	0	0	0	0	0	0	2	3
% Pedestrians	0.0%	0.0%	0.0%	0.0%	0.0%	100.0%	100.0%	0.0%	0.0%	0.0%	0.0%	0.0%	100.0%	100.0%	0.0%	0.0%	0.0%	0.0%	0.0%	0.0%	100.0%
Bicycles on Crosswalk	0	0	0	0	0	0	0	0	0	0	0	0	0	0	0	0	0	0	0	0	0
% Bicycles on Crosswalk	0.0%	0.0%	0.0%	0.0%	0.0%	0.0%	0.0%	0.0%	0.0%	0.0%	0.0%	0.0%	0.0%	0.0%	0.0%	0.0%	0.0%	0.0%	0.0%	0.0%	0.0%

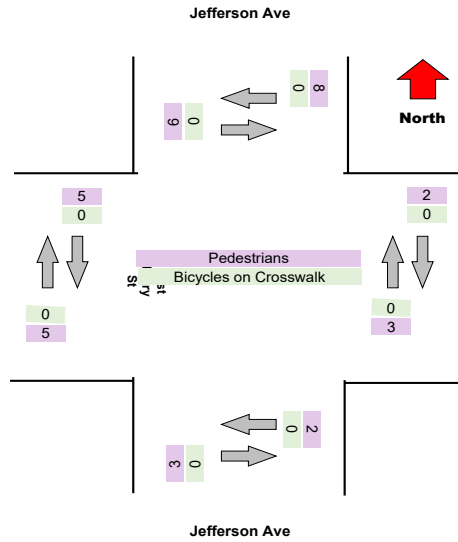
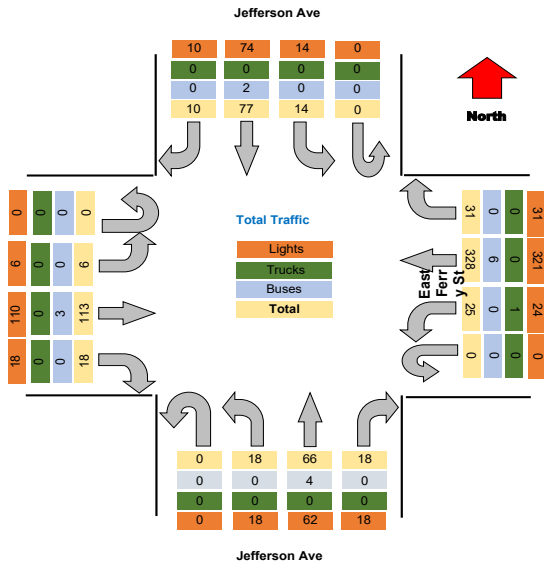

### Turning Movement Peak Hour Data (PM)

4:15:00 PM

Leg Direction	Jefferson Ave					East Ferry St					Jefferson Ave					East Ferry St					Total	
	Southbound					Westbound					Northbound					Eastbound						
Start Time	Right	Thru	Left	U-Turn	App Total	Right	Thru	Left	U-Turn	App Total	Right	Thru	Left	U-Turn	App Total	Right	Thru	Left	U-Turn	App Total	Peds CW	Peds CCW
4:15:00 PM	5	33	5	0	43	10	93	13	0	116	16	47	13	0	76	12	47	9	0	68	3	1
4:30:00 PM	6	46	6	0	58	13	85	9	0	107	22	46	13	0	81	18	47	7	0	72	2	1
4:45:00 PM	3	35	7	0	45	5	97	13	0	115	8	43	13	0	64	7	50	12	0	69	2	1
5:00:00 PM	11	31	11	0	53	17	75	9	0	102	15	43	8	0	66	18	45	11	0	74	0	1
<b>Grand Total</b>	<b>25</b>	<b>145</b>	<b>29</b>	<b>0</b>	<b>199</b>	<b>45</b>	<b>351</b>	<b>44</b>	<b>0</b>	<b>440</b>	<b>64</b>	<b>179</b>	<b>47</b>	<b>0</b>	<b>290</b>	<b>55</b>	<b>189</b>	<b>39</b>	<b>0</b>	<b>233</b>	<b>7</b>	<b>4</b>
% Approach	12.6%	72.9%	14.6%	0.0%	0.0%	10.2%	79.8%	10.0%	0.0%	0.0%	22.1%	61.7%	16.2%	0.0%	0.0%	19.4%	66.8%	13.8%	0.0%	0.0%	0.0%	0.0%
% Total	2.1%	12.0%	2.4%	0.0%	16.4%	3.7%	29.0%	3.6%	0.0%	36.3%	5.3%	14.8%	3.9%	0.0%	23.9%	4.5%	15.6%	3.2%	0.0%	23.3%	0.0%	0.0%
PHF	0.568	0.788	0.659	0.000	0.858	0.662	0.905	0.846	0.000	0.948	0.727	0.952	0.904	0.000	0.895	0.764	0.945	0.813	0.000	0.956	0.000	0.000
Lights	25	141	29	0	195	45	346	43	0	434	64	176	46	0	286	54	186	39	0	279	0	0
% Lights	100.0%	97.2%	100.0%	0.0%	98.0%	100.0%	98.6%	97.7%	0.0%	98.6%	100.0%	98.3%	97.9%	0.0%	98.6%	98.2%	98.4%	100.0%	0.0%	98.6%	0.0%	0.0%
Trucks	0	0	0	0	0	0	0	1	0	1	0	0	0	0	0	0	0	0	0	0	0	0
% Trucks	0.0%	0.0%	0.0%	0.0%	0.0%	0.0%	0.0%	2.3%	0.0%	0.2%	0.0%	0.0%	0.0%	0.0%	0.0%	0.0%	0.0%	0.0%	0.0%	0.0%	0.0%	0.0%
Buses	0	3	0	0	3	0	5	0	0	5	0	2	1	0	3	1	3	0	0	4	0	0
% Buses	0.0%	2.1%	0.0%	0.0%	0.0%	0.0%	1.4%	0.0%	0.0%	0.0%	0.0%	1.1%	2.1%	0.0%	0.0%	1.8%	1.6%	0.0%	0.0%	0.0%	0.0%	0.0%
Pedestrians	0	0	0	0	0	7	4	0	0	11	0	0	0	0	0	0	0	0	0	0	7	4
% Pedestrians	0.0%	0.0%	0.0%	0.0%	0.0%	100.0%	100.0%	0.0%	0.0%	0.0%	0.0%	0.0%	0.0%	0.0%	0.0%	0.0%	0.0%	0.0%	0.0%	0.0%	100.0%	100.0%
Bicycles on Crosswalk	0	0	0	0	0	0	0	0	0	0	0	0	0	0	0	0	0	0	0	0	0	0
% Bicycles on Crosswalk	0.0%	0.0%	0.0%	0.0%	0.0%	0.0%	0.0%	0.0%	0.0%	0.0%	0.0%	0.0%	0.0%	0.0%	0.0%	0.0%	0.0%	0.0%	0.0%	0.0%	0.0%	0.0%

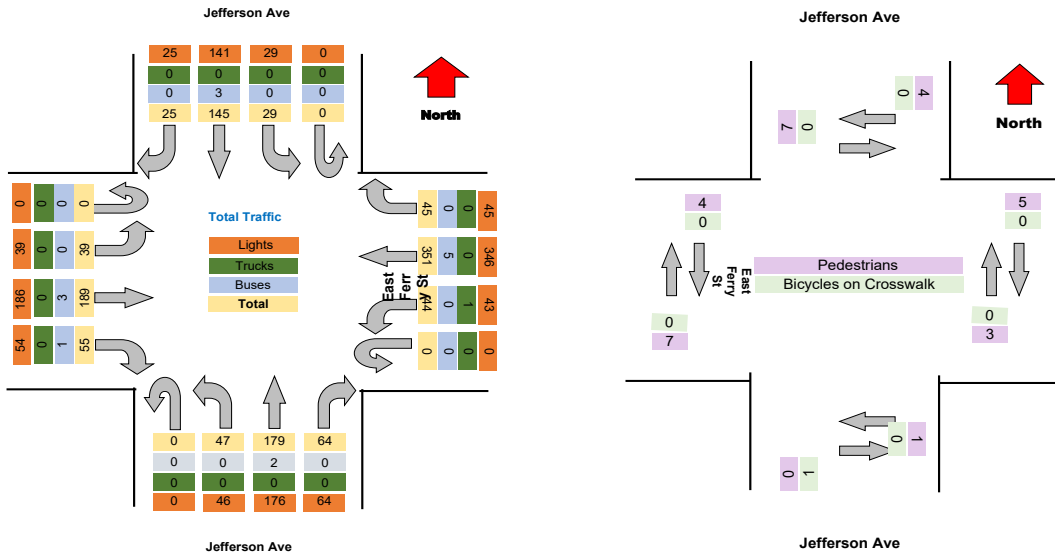

Project : VBH Malta NY  
 Site : Site 4  
 Location : 42.948550, -73.790036

TSTData.com

Survey Date : 2021-04-28, Wednesday

Project	LaBella
Project Code	LaBella
Site Name	32
Legs and Movements	All Processed Legs & Move
Bin Size	15 minutes
Survey Date	2021-11-03, Wednesday
Location	32
Latitude and Longitude	42.914969, -78.853981

	Start	End	PHF
Forced Peak AM	2021/11/03 07:30:00	2021/11/03 08:30:00	0.84
Forced Peak PM	2021/11/03 16:30:00	2021/11/03 17:30:00	0.96
AM Peak	2021/11/03 07:30:00	2021/11/03 08:30:00	0.84
PM Peak	2021/11/03 16:15:00	2021/11/03 17:15:00	0.95

### Turning Movement Data

Leg Direction	Jefferson Ave							East Ferry St							Jefferson Ave							East Ferry St							Total				
	Southbound			Northbound				Westbound			Eastbound				Northbound			Eastbound															
Start Time	Right	Thru	Left	U-Turn	App Total	Peds CV	Peds CCV	Right	Thru	Left	U-Turn	App Total	Peds CV	Peds CCV	Right	Thru	Left	U-Turn	App Total	Peds CV	Peds CCV	Right	Thru	Left	U-Turn	App Total	Peds CV	Peds CCV					
6:30:00 AM	3	6	4	0	13	1	2	6	39	2	0	49	0	0	4	13	4	0	21	1	0	3	21	0	0	5	15	1	0	21	1	0	107
6:45:00 AM	2	18	1	0	21	0	0	6	58	1	0	65	0	0	3	5	4	0	12	0	0	5	15	1	0	21	1	0	21	1	0	117	
Hourly Total	5	24	5	0	34	1	2	12	95	3	0	112	0	0	7	18	8	0	33	1	0	8	36	1	0	45	1	0	45	1	0	224	
7:00:00 AM	2	14	3	0	19	1	3	4	59	4	0	70	0	0	5	28	2	0	35	3	0	6	28	3	0	35	2	4	159				
7:15:00 AM	5	15	1	0	21	1	1	5	74	8	0	86	0	0	5	22	7	0	34	0	0	11	30	5	0	46	2	0	167				
7:30:00 AM	5	18	4	0	27	0	1	6	106	11	0	124	1	0	6	24	4	0	35	3	0	8	49	4	0	61	1	0	247				
7:45:00 AM	5	46	6	0	57	1	0	9	132	13	0	154	0	0	5	17	7	0	29	1	0	14	53	6	0	73	0	0	313				
Hourly Total	17	93	14	0	124	3	5	24	371	34	0	434	1	0	21	91	20	0	133	7	0	39	158	18	0	215	5	4	906				
8:00:00 AM	4	25	3	0	32	1	3	11	109	10	0	133	1	4	3	33	13	0	54	1	0	14	45	7	0	66	0	2	285				
8:15:00 AM	6	24	4	0	34	0	0	10	65	8	0	83	1	0	7	25	9	0	42	0	0	4	41	8	0	53	1	0	212				
Hourly Total	10	49	7	0	66	1	3	21	174	18	0	216	2	4	10	58	22	0	96	1	0	18	86	15	0	119	1	2	497				
4:00:00 PM	4	40	9	0	53	1	0	14	86	10	0	110	0	0	12	59	11	0	82	3	1	16	67	8	0	91	3	1	336				
4:15:00 PM	9	37	9	0	55	0	1	18	92	15	0	125	0	1	18	50	17	0	85	0	0	9	58	6	0	73	1	0	338				
4:30:00 PM	6	60	14	0	80	1	2	14	83	11	0	108	2	2	17	38	13	0	68	0	1	12	53	5	0	70	0	0	326				
4:45:00 PM	4	33	10	0	47	0	3	13	94	6	0	113	0	1	15	43	14	0	72	1	1	12	61	3	0	66	3	2	298				
Hourly Total	23	170	42	0	235	2	6	59	355	42	0	456	2	4	62	190	55	0	397	4	3	49	229	22	0	390	7	3	1298				
5:00:00 PM	4	39	9	0	52	0	1	11	78	20	0	108	0	1	15	58	15	0	86	0	0	16	54	8	0	78	0	0	322				
5:15:00 PM	5	37	7	0	49	0	2	9	105	12	0	126	0	0	20	54	14	0	88	0	0	13	52	5	0	70	1	1	333				
5:30:00 PM	3	42	7	0	52	1	4	12	80	16	0	108	0	0	10	42	15	0	67	0	2	13	52	3	0	68	1	2	295				
5:45:00 PM	5	32	4	0	41	1	1	11	88	11	0	120	0	0	17	41	10	0	68	0	0	6	46	5	0	57	1	4	286				
Hourly Total	17	150	27	0	194	2	8	43	358	59	0	460	0	1	62	193	54	0	309	0	2	48	204	21	0	273	3	7	1236				
Grand Total	72	486	95	0	653	9	24	159	1353	156	0	1678	5	9	162	550	159	0	878	13	5	162	713	77	0	952	17	15	4181				
% Approach	11.0%	74.4%	14.5%	0.0%	0.0%	0.0%	0.0%	9.5%	80.6%	9.3%	0.0%	0.0%	0.0%	0.0%	18.5%	62.6%	18.1%	0.0%	0.0%	0.0%	0.0%	17.0%	74.9%	8.1%	0.0%	0.0%	0.0%	0.0%	0.0%	0.0%			
% Total	1.7%	11.7%	2.3%	0.0%	15.7%	0.0%	0.0%	3.8%	32.5%	3.7%	0.0%	40.3%	0.0%	0.0%	3.9%	13.2%	3.8%	0.0%	21.1%	0.0%	0.0%	3.9%	17.1%	1.9%	0.0%	22.9%	0.0%	0.0%	0.0%				
Lights	66	471	91	0	628	0	0	147	1300	145	0	1592	0	0	158	526	154	0	838	0	0	153	667	71	0	891	0	0	3949				
% Lights	91.7%	96.9%	95.8%	0.0%	96.2%	0.0%	0.0%	92.5%	96.1%	92.9%	0.0%	94.9%	0.0%	0.0%	97.5%	95.6%	96.9%	0.0%	95.4%	0.0%	0.0%	94.4%	93.5%	92.2%	0.0%	93.6%	0.0%	0.0%	94.9%				
Trucks	0	1	0	0	1	0	0	0	0	0	0	0	0	0	0	0	0	0	0	0	0	0	1	0	0	1	0	0	2				
% Trucks	0.0%	0.2%	0.0%	0.0%	0.2%	0.0%	0.0%	0.0%	0.0%	0.0%	0.0%	0.0%	0.0%	0.0%	0.0%	0.0%	0.0%	0.0%	0.0%	0.0%	0.0%	0.0%	0.1%	0.0%	0.0%	0.1%	0.0%	0.0%	0.0%				
Buses	6	14	4	0	24	0	0	12	53	11	0	76	0	0	4	24	5	0	33	0	0	9	45	6	0	60	0	0	193				
% Buses	8.3%	2.9%	4.2%	0.0%	0.0%	0.0%	0.0%	0.0%	3.9%	7.1%	0.0%	0.0%	0.0%	0.0%	2.5%	4.4%	3.1%	0.0%	0.0%	0.0%	0.0%	5.6%	6.3%	7.8%	0.0%	0.0%	0.0%	4.6%					
Pedestrians	0	0	0	0	0	9	23	0	0	0	0	0	5	8	0	0	0	0	0	13	5	0	0	0	0	0	17	12	0				
% Pedestrians	0.0%	0.0%	0.0%	0.0%	0.0%	100.0%	85.8%	0.0%	0.0%	0.0%	0.0%	0.0%	100.0%	88.9%	0.0%	0.0%	0.0%	0.0%	0.0%	100.0%	100.0%	0.0%	0.0%	0.0%	0.0%	0.0%	0.0%	100.0%	75.0%	0.0%			
Bicycles on Crosswalk	0	0	0	0	0	0	1	0	0	0	0	0	0	1	0	0	0	0	0	0	0	0	0	0	0	0	0	0	4	0			
% Bicycles on Crosswalk	0.0%	0.0%	0.0%	0.0%	0.0%	0.0%	4.2%	0.0%	0.0%	0.0%	0.0%	0.0%	0.0%	11.1%	0.0%	0.0%	0.0%	0.0%	0.0%	0.0%	0.0%	0.0%	0.0%	0.0%	0.0%	0.0%	0.0%	0.0%	25.0%	0.0%			

Project : VBH Malta NY  
 Site : Site 4  
 Location : 42.948550, -73.790036  
 Survey Date : 2021-04-28, Wednesday

### Turning Movement Data Plot

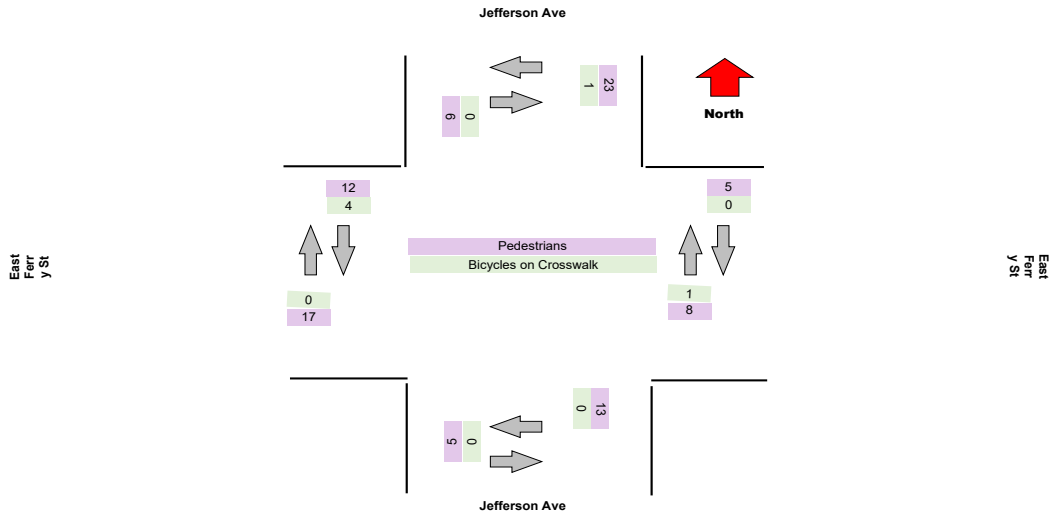
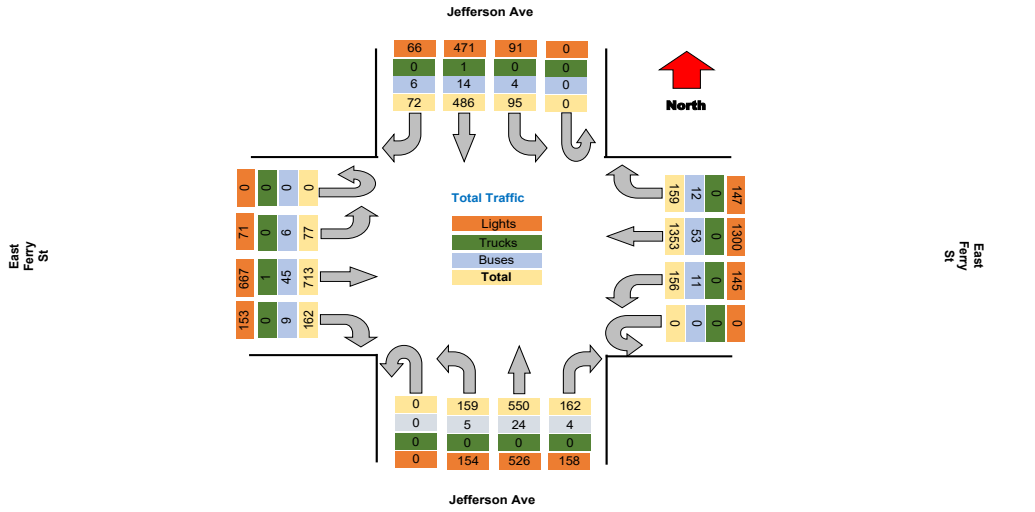

### Turning Movement Peak Hour Data (AM)

7:30:00 AM

Leg Direction	Jefferson Ave						East Ferry St						Jefferson Ave						East Ferry St						Total					
	Southbound			Northbound			Westbound			Eastbound			Northbound			Eastbound														
Start Time	Right	Thru	Left	U-Turn	App Total	Peds CW	Peds CCW	Right	Thru	Left	U-Turn	App Total	Peds CW	Peds CCW	Right	Thru	Left	U-Turn	App Total	Peds CW	Peds CCW	Right	Thru	Left	U-Turn	App Total	Peds CW	Peds CCW		
7:30:00 AM	5	18	4	0	27	0	1	6	106	11	0	124	1	0	6	24	4	0	35	3	0	8	49	4	0	61	1	0	247	
7:45:00 AM	5	46	6	0	57	1	0	9	132	13	0	154	0	0	5	17	7	0	29	1	0	14	53	6	0	73	0	0	313	
8:00:00 AM	4	25	3	0	32	1	0	11	109	10	0	133	1	4	3	33	13	0	54	1	0	14	45	7	0	66	0	2	285	
8:15:00 AM	6	24	4	0	34	0	0	10	65	8	0	83	1	0	7	25	9	0	42	0	0	4	41	8	0	53	1	0	212	
<b>Grand Total</b>	<b>20</b>	<b>113</b>	<b>17</b>	<b>0</b>	<b>150</b>	<b>2</b>	<b>1</b>	<b>36</b>	<b>412</b>	<b>42</b>	<b>0</b>	<b>494</b>	<b>3</b>	<b>4</b>	<b>21</b>	<b>99</b>	<b>33</b>	<b>0</b>	<b>150</b>	<b>3</b>	<b>0</b>	<b>40</b>	<b>188</b>	<b>23</b>	<b>0</b>	<b>253</b>	<b>2</b>	<b>2</b>	<b>1057</b>	
% Approach	13.3%	75.3%	11.3%	0.0%	0.0%	0.0%	0.0%	7.3%	83.4%	8.5%	0.0%	0.0%	0.0%	0.0%	13.1%	61.9%	20.6%	0.0%	0.0%	0.0%	0.0%	15.8%	74.3%	9.8%	0.0%	0.0%	0.0%	0.0%	0.0%	
% Total	1.9%	10.7%	1.6%	0.0%	14.2%	0.0%	0.0%	3.4%	39.0%	4.0%	0.0%	46.7%	0.0%	0.0%	2.0%	9.4%	3.1%	0.0%	15.1%	0.0%	0.0%	3.8%	17.8%	2.4%	0.0%	23.9%	0.0%	0.0%	0.0%	
PHF	0.833	0.614	0.708	0.000	0.658	0.000	0.000	0.818	0.780	0.808	0.000	0.802	0.000	0.000	0.750	0.750	0.635	0.000	0.741	0.000	0.000	0.714	0.887	0.781	0.000	0.866	0.000	0.000	0.844	
Lights	18	110	15	0	143	0	0	33	395	37	0	465	0	0	18	91	31	0	140	0	0	36	169	23	0	228	0	0	976	
% Lights	80.0%	97.3%	88.2%	0.0%	95.3%	0.0%	0.0%	81.7%	95.9%	88.1%	0.0%	94.1%	0.0%	0.0%	85.7%	91.9%	93.9%	0.0%	87.5%	0.0%	0.0%	90.0%	89.9%	92.0%	0.0%	90.1%	0.0%	0.0%	92.3%	
Trucks	0	0	0	0	0	0	0	0	0	0	0	0	0	0	0	0	0	0	0	0	0	0	1	0	0	1	0	0	1	
% Trucks	0.0%	0.0%	0.0%	0.0%	0.0%	0.0%	0.0%	0.0%	0.0%	0.0%	0.0%	0.0%	0.0%	0.0%	0.0%	0.0%	0.0%	0.0%	0.0%	0.0%	0.0%	0.0%	0.5%	0.0%	0.0%	0.4%	0.0%	0.0%	0.1%	
Buses	2	3	2	0	7	0	0	3	17	5	0	25	0	0	3	8	2	0	13	0	0	4	18	2	0	24	0	0	69	
% Buses	10.0%	2.7%	11.8%	0.0%	0.0%	0.0%	0.0%	8.3%	4.1%	11.9%	0.0%	0.0%	0.0%	0.0%	14.3%	8.1%	6.1%	0.0%	0.0%	0.0%	0.0%	10.0%	9.8%	8.0%	0.0%	0.0%	0.0%	6.5%		
Pedestrians	0	0	0	0	0	2	4	0	0	0	0	3	4	0	0	0	0	0	0	5	0	0	0	0	0	0	2	1	0	
% Pedestrians	0.0%	0.0%	0.0%	0.0%	0.0%	100.0%	100.0%	0.0%	0.0%	0.0%	0.0%	0.0%	100.0%	100.0%	0.0%	0.0%	0.0%	0.0%	0.0%	0.0%	100.0%	0.0%	0.0%	0.0%	0.0%	0.0%	0.0%	100.0%	50.0%	0.0%
Bicycles on Crosswalk	0	0	0	0	0	0	0	0	0	0	0	0	0	0	0	0	0	0	0	0	0	0	0	0	0	0	0	0	1	0
% Bicycles on Crosswalk	0.0%	0.0%	0.0%	0.0%	0.0%	0.0%	0.0%	0.0%	0.0%	0.0%	0.0%	0.0%	0.0%	0.0%	0.0%	0.0%	0.0%	0.0%	0.0%	0.0%	0.0%	0.0%	0.0%	0.0%	0.0%	0.0%	0.0%	50.0%	0.0%	

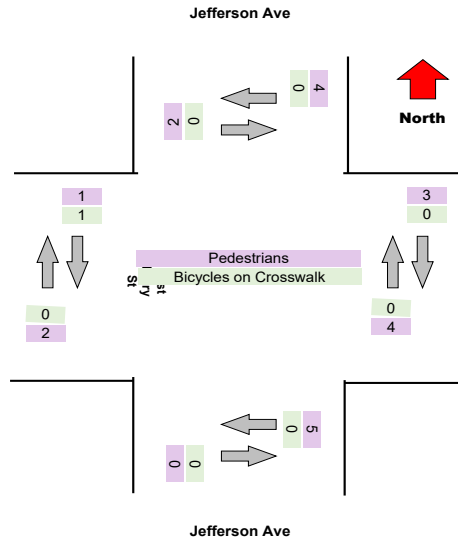
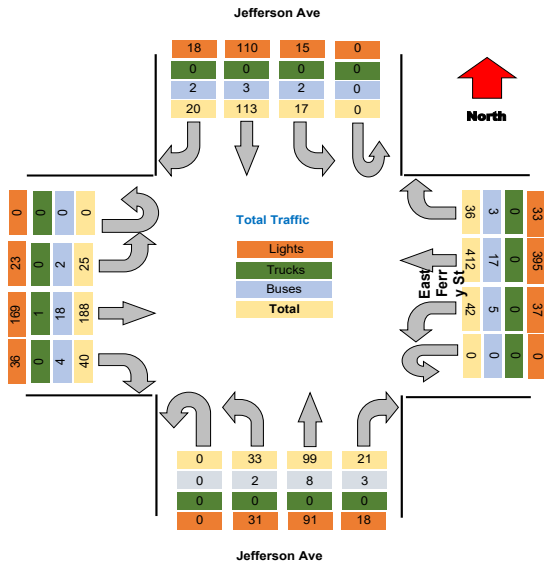

**Turning Movement Peak Hour Data (PM)**

4:15:00 PM

Leg Direction	Jefferson Ave				East Ferry St				Jefferson Ave				East Ferry St				Total					
	Southbound		Northbound		Westbound		Eastbound		Northbound		Southbound		Westbound									
Start Time	Right	Thru	Left	U-Turn	App Total	Peds CW	Peds CCW	Right	Thru	Left	U-Turn	App Total	Peds CW	Peds CCW	Right	Thru	Left	U-Turn	App Total	Peds CW	Peds CCW	
4:15:00 PM	9	37	9	0	55	0	1	18	92	15	0	125	0	1	18	50	17	0	85	0	0	338
4:30:00 PM	6	60	14	0	80	1	2	14	83	11	0	108	2	2	12	53	5	0	70	0	0	326
4:45:00 PM	4	33	10	0	47	0	3	13	94	6	0	113	0	1	15	43	14	0	72	1	1	298
5:00:00 PM	4	39	9	0	52	0	1	11	75	20	0	106	0	1	15	56	15	0	86	0	0	322
<b>Grand Total</b>	<b>23</b>	<b>169</b>	<b>42</b>	<b>0</b>	<b>234</b>	<b>1</b>	<b>7</b>	<b>56</b>	<b>344</b>	<b>52</b>	<b>0</b>	<b>452</b>	<b>2</b>	<b>6</b>	<b>65</b>	<b>187</b>	<b>59</b>	<b>0</b>	<b>311</b>	<b>1</b>	<b>2</b>	<b>1284</b>
% Approach	9.8%	72.2%	17.9%	0.0%	0.0%	0.0%	0.0%	12.4%	76.1%	11.5%	0.0%	0.0%	0.0%	0.0%	20.9%	60.1%	19.0%	0.0%	0.0%	0.0%	0.0%	0.0%
% Total	1.8%	13.2%	3.3%	0.0%	18.2%	0.0%	0.0%	4.4%	26.8%	4.0%	0.0%	35.2%	0.0%	0.0%	5.1%	14.6%	4.6%	0.0%	24.2%	0.0%	0.0%	0.0%
PHF	0.639	0.704	0.750	0.000	0.731	0.000	0.000	0.778	0.915	0.650	0.000	0.904	0.000	0.000	0.903	0.835	0.868	0.000	0.904	0.000	0.000	0.950
Lights	22	163	42	0	227	0	0	51	334	48	0	433	0	0	65	181	57	0	303	0	0	1238
% Lights	95.7%	96.4%	100.0%	0.0%	97.0%	0.0%	0.0%	91.1%	97.1%	92.3%	0.0%	95.8%	0.0%	0.0%	100.0%	96.8%	96.6%	0.0%	97.4%	0.0%	0.0%	96.4%
Trucks	0	0	0	0	0	0	0	0	0	0	0	0	0	0	0	0	0	0	0	0	0	0
% Trucks	0.0%	0.0%	0.0%	0.0%	0.0%	0.0%	0.0%	0.0%	0.0%	0.0%	0.0%	0.0%	0.0%	0.0%	0.0%	0.0%	0.0%	0.0%	0.0%	0.0%	0.0%	0.0%
Buses	1	6	0	0	7	0	0	5	10	4	0	19	0	0	0	6	2	0	8	0	0	46
% Buses	4.3%	3.6%	0.0%	0.0%	0.0%	0.0%	0.0%	8.9%	2.9%	7.7%	0.0%	0.0%	0.0%	0.0%	0.0%	3.2%	3.4%	0.0%	0.0%	0.0%	0.0%	3.6%
Pedestrians	0	0	0	0	0	1	6	0	0	0	0	0	2	4	0	0	0	0	0	1	2	0
% Pedestrians	0.0%	0.0%	0.0%	0.0%	0.0%	100.0%	85.7%	0.0%	0.0%	0.0%	0.0%	0.0%	100.0%	80.0%	0.0%	0.0%	0.0%	0.0%	0.0%	0.0%	100.0%	100.0%
Bicycles on Crosswalk	0	0	0	0	0	0	1	0	0	0	0	0	0	1	0	0	0	0	0	0	0	0
% Bicycles on Crosswalk	0.0%	0.0%	0.0%	0.0%	0.0%	0.0%	14.3%	0.0%	0.0%	0.0%	0.0%	0.0%	0.0%	20.0%	0.0%	0.0%	0.0%	0.0%	0.0%	0.0%	0.0%	0.0%

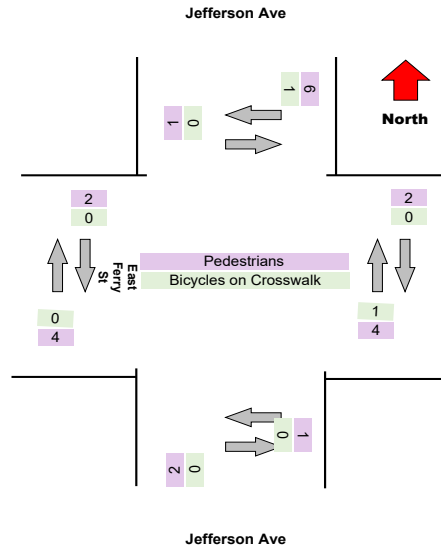
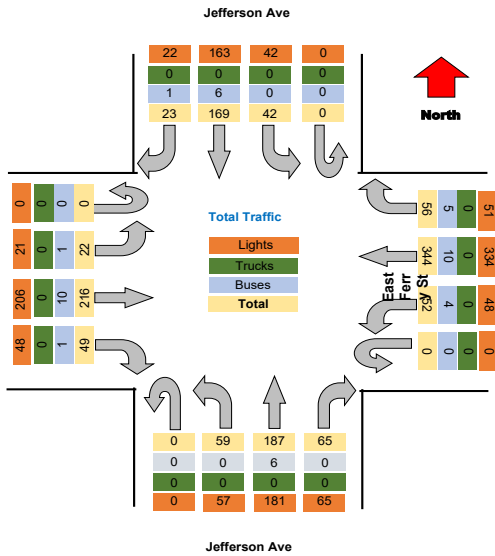



Project : VBH Malta NY  
 Site : Site 4  
 Location : 42.948550, -73.790036  
 Survey Date : 2021-04-28, Wednesday

### Turning Movement Data Plot

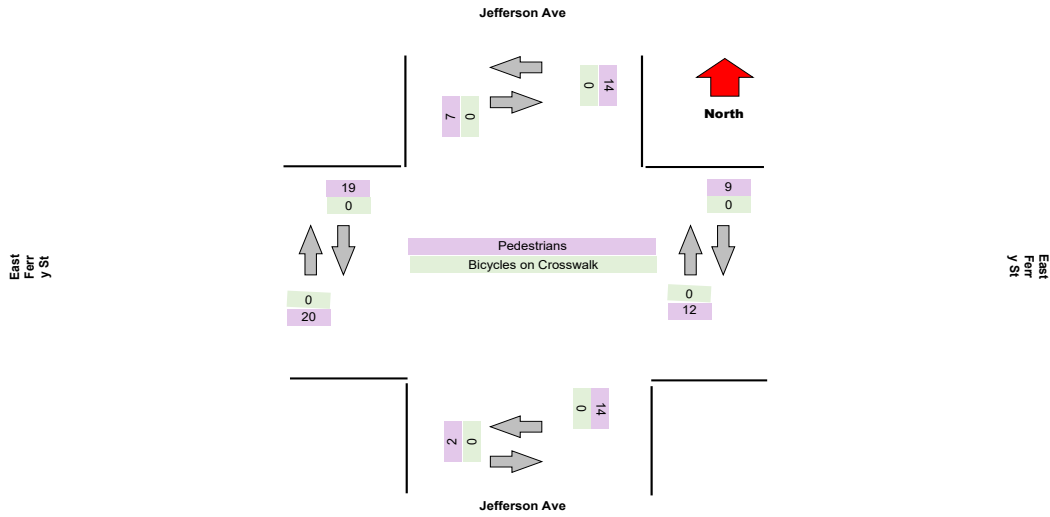
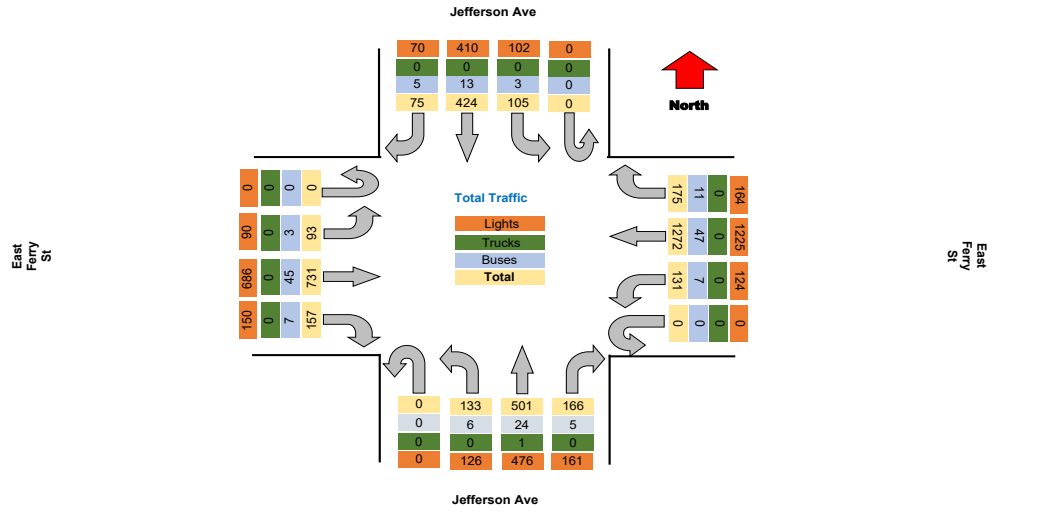



**Turning Movement Peak Hour Data (AM)**

7:30:00 AM

Leg Direction	Jefferson Ave						East Ferry St						Jefferson Ave						East Ferry St						Total				
	Southbound			Northbound			Westbound			Eastbound			Northbound			Eastbound													
Start Time	Right	Thru	Left	U-Turn	App Total	Peds CW	Peds CCW	Right	Thru	Left	U-Turn	App Total	Peds CW	Peds CCW	Right	Thru	Left	U-Turn	App Total	Peds CW	Peds CCW	Right	Thru	Left	U-Turn	App Total	Peds CW	Peds CCW	
7:30:00 AM	7	19	6	0	32	0	2	5	105	7	0	119	0	1	6	14	6	0	27	4	1	9	45	9	0	63	0	1	241
7:45:00 AM	10	20	6	0	36	0	3	14	131	7	0	155	1	0	4	21	8	0	34	0	0	17	62	3	0	82	0	2	307
8:00:00 AM	5	31	7	0	43	0	0	19	102	6	0	129	0	3	10	27	9	0	49	1	1	12	52	3	0	67	1	2	288
8:15:00 AM	5	25	8	0	39	1	0	8	69	11	0	87	1	0	8	30	2	0	41	0	0	8	40	7	0	55	2	1	222
Grand Total	27	95	27	0	150	1	5	46	406	33	0	490	2	4	28	92	25	0	151	5	2	46	199	22	0	287	3	6	1088
% Approach	18.0%	64.0%	18.0%	0.0%	0.0%	0.0%	0.0%	9.4%	82.9%	6.7%	0.0%	0.0%	0.0%	0.0%	18.5%	60.9%	16.6%	0.0%	0.0%	0.0%	0.0%	17.2%	74.5%	8.2%	0.0%	0.0%	0.0%	0.0%	0.0%
% Total	2.6%	9.1%	2.6%	0.0%	14.2%	0.0%	0.0%	4.3%	38.4%	3.1%	0.0%	46.3%	0.0%	0.0%	2.6%	8.7%	2.4%	0.0%	14.3%	0.0%	0.0%	4.3%	18.8%	2.1%	0.0%	25.2%	0.0%	0.0%	0.0%
PHF	0.675	0.774	0.844	0.000	0.872	0.000	0.000	0.605	0.775	0.750	0.000	0.790	0.000	0.000	0.700	0.767	0.694	0.000	0.770	0.000	0.000	0.676	0.802	0.611	0.000	0.814	0.000	0.000	0.862
Lights	25	94	25	0	144	0	0	42	389	29	0	460	0	0	25	83	23	0	131	0	0	43	184	21	0	248	0	0	983
% Lights	92.6%	97.9%	92.6%	0.0%	96.0%	0.0%	0.0%	91.3%	95.8%	87.9%	0.0%	93.9%	0.0%	0.0%	89.3%	90.2%	92.0%	0.0%	86.8%	0.0%	0.0%	93.5%	92.5%	95.5%	0.0%	92.9%	0.0%	0.0%	92.9%
Trucks	0	0	0	0	0	0	0	0	0	0	0	0	0	0	0	0	0	0	0	0	0	0	0	0	0	0	0	0	0
% Trucks	0.0%	0.0%	0.0%	0.0%	0.0%	0.0%	0.0%	0.0%	0.0%	0.0%	0.0%	0.0%	0.0%	0.0%	0.0%	0.0%	0.0%	0.0%	0.0%	0.0%	0.0%	0.0%	0.0%	0.0%	0.0%	0.0%	0.0%	0.0%	0.0%
Buses	2	2	2	0	6	0	0	4	17	4	0	25	0	0	3	9	2	0	14	0	0	3	15	1	0	19	0	0	64
% Buses	7.4%	2.1%	7.4%	0.0%	0.0%	0.0%	0.0%	8.7%	4.2%	12.1%	0.0%	0.0%	0.0%	0.0%	10.7%	9.8%	8.0%	0.0%	0.0%	0.0%	0.0%	6.5%	7.5%	4.5%	0.0%	0.0%	0.0%	0.0%	6.0%
Pedestrians	0	0	0	0	0	1	5	0	0	0	0	2	4	0	0	0	0	0	0	5	2	0	0	0	0	0	3	6	0
% Pedestrians	0.0%	0.0%	0.0%	0.0%	0.0%	100.0%	100.0%	0.0%	0.0%	0.0%	0.0%	0.0%	100.0%	100.0%	0.0%	0.0%	0.0%	0.0%	0.0%	0.0%	100.0%	100.0%	0.0%	0.0%	0.0%	0.0%	0.0%	100.0%	100.0%
Bicycles on Crosswalk	0	0	0	0	0	0	0	0	0	0	0	0	0	0	0	0	0	0	0	0	0	0	0	0	0	0	0	0	0
% Bicycles on Crosswalk	0.0%	0.0%	0.0%	0.0%	0.0%	0.0%	0.0%	0.0%	0.0%	0.0%	0.0%	0.0%	0.0%	0.0%	0.0%	0.0%	0.0%	0.0%	0.0%	0.0%	0.0%	0.0%	0.0%	0.0%	0.0%	0.0%	0.0%	0.0%	0.0%

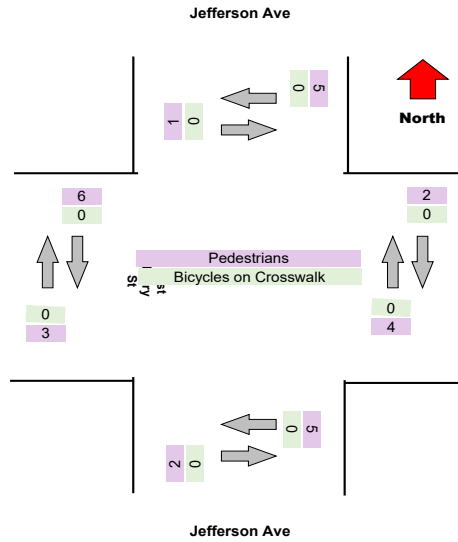
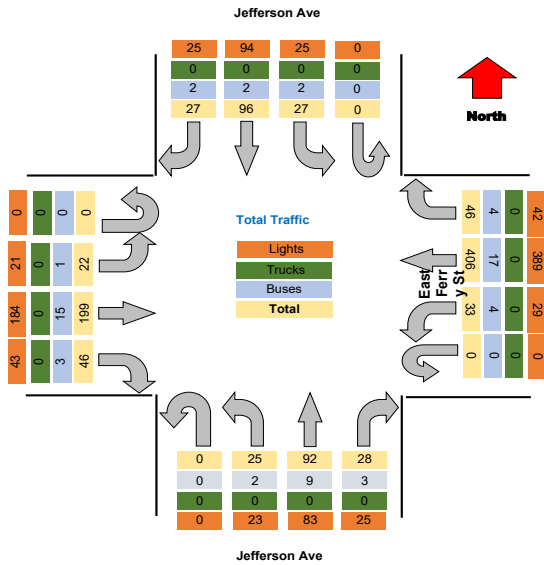

**Turning Movement Peak Hour Data (PM)**

4:15:00 PM

Leg Direction	Jefferson Ave					East Ferry St					Jefferson Ave					East Ferry St					Total		
	Southbound					Westbound					Northbound					Eastbound							
Start Time	Right	Thru	Left	U-Turn	App Total	Peds CW	Peds CCW	Right	Thru	Left	U-Turn	App Total	Peds CW	Peds CCW	Right	Thru	Left	U-Turn	App Total	Peds CW	Peds CCW	Total	
4:15:00 PM	6	36	11	0	53	0	0	14	81	11	0	106	0	1	19	54	15	0	88	0	0	324	
4:30:00 PM	4	36	7	0	47	0	1	9	93	10	0	112	2	1	15	39	7	0	61	1	0	319	
4:45:00 PM	6	35	8	0	49	1	3	14	86	15	0	115	1	2	20	40	13	0	73	0	0	310	
5:00:00 PM	8	41	8	0	57	0	0	19	82	8	0	109	0	1	15	54	6	0	75	2	0	321	
<b>Grand Total</b>	<b>24</b>	<b>148</b>	<b>34</b>	<b>0</b>	<b>206</b>	<b>1</b>	<b>4</b>	<b>56</b>	<b>342</b>	<b>44</b>	<b>0</b>	<b>442</b>	<b>3</b>	<b>5</b>	<b>69</b>	<b>187</b>	<b>41</b>	<b>0</b>	<b>297</b>	<b>3</b>	<b>4</b>	<b>1274</b>	
% Approach	11.7%	71.8%	16.5%	0.0%	0.0%	0.0%	0.0%	12.7%	77.4%	10.0%	0.0%	0.0%	0.0%	0.0%	23.2%	63.0%	13.8%	0.0%	0.0%	0.0%	0.0%	0.0%	0.0%
% Total	1.9%	11.6%	2.7%	0.0%	16.2%	0.0%	0.0%	4.4%	26.8%	3.5%	0.0%	34.7%	0.0%	0.0%	5.4%	14.7%	3.2%	0.0%	23.3%	0.0%	0.0%	0.0%	0.0%
PHF	0.750	0.902	0.773	0.000	0.904	0.000	0.000	0.737	0.919	0.733	0.000	0.961	0.000	0.000	0.863	0.866	0.683	0.000	0.844	0.000	0.000	0.000	0.983
Lights	21	144	34	0	199	0	0	51	333	42	0	426	0	0	68	182	38	0	288	0	0	1228	
% Lights	87.5%	97.3%	100.0%	0.0%	96.6%	0.0%	0.0%	81.1%	97.4%	95.5%	0.0%	96.4%	0.0%	0.0%	88.6%	97.3%	92.7%	0.0%	97.0%	0.0%	0.0%	96.4%	
Trucks	0	0	0	0	0	0	0	0	0	0	0	0	0	0	0	0	0	0	0	0	0	0	
% Trucks	0.0%	0.0%	0.0%	0.0%	0.0%	0.0%	0.0%	0.0%	0.0%	0.0%	0.0%	0.0%	0.0%	0.0%	0.0%	0.0%	0.0%	0.0%	0.0%	0.0%	0.0%	0.0%	
Buses	3	4	0	0	7	0	0	5	9	2	0	16	0	0	1	5	3	0	9	0	0	46	
% Buses	12.5%	2.7%	0.0%	0.0%	0.0%	0.0%	0.0%	8.9%	2.6%	4.5%	0.0%	0.0%	0.0%	0.0%	1.4%	2.7%	7.3%	0.0%	0.0%	0.0%	0.0%	3.6%	
Pedestrians	0	0	0	0	0	1	4	0	0	0	0	3	5	0	0	0	0	0	3	0	0	4	
% Pedestrians	0.0%	0.0%	0.0%	0.0%	0.0%	100.0%	100.0%	0.0%	0.0%	0.0%	0.0%	0.0%	100.0%	100.0%	0.0%	0.0%	0.0%	0.0%	0.0%	0.0%	0.0%	0.0%	
Bicycles on Crosswalk	0	0	0	0	0	0	0	0	0	0	0	0	0	0	0	0	0	0	0	0	0	0	
% Bicycles on Crosswalk	0.0%	0.0%	0.0%	0.0%	0.0%	0.0%	0.0%	0.0%	0.0%	0.0%	0.0%	0.0%	0.0%	0.0%	0.0%	0.0%	0.0%	0.0%	0.0%	0.0%	0.0%	0.0%	

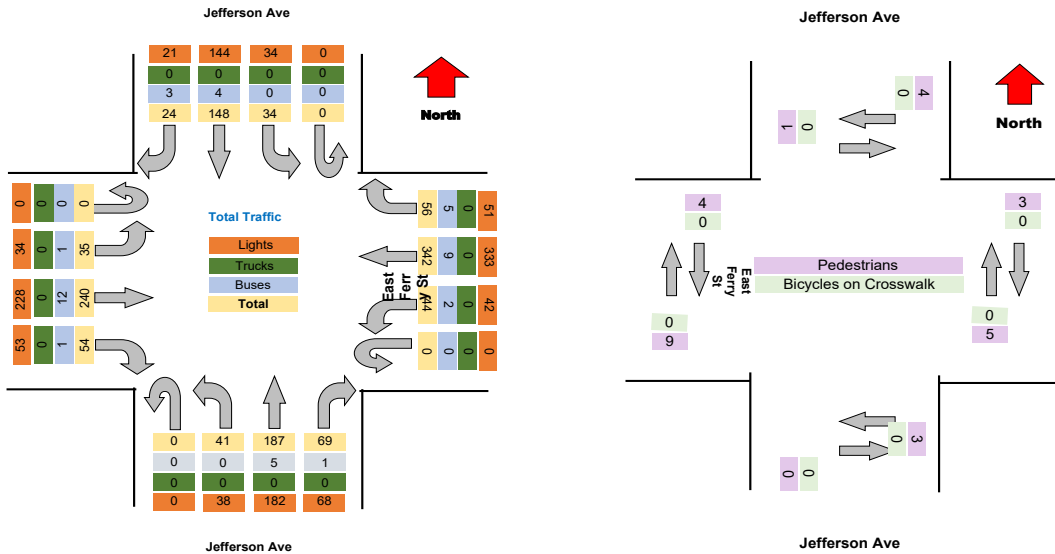

Project : VBH Malta NY  
 Site : Site 4  
 Location : 42.948550, -73.790036

TSTData.com

Survey Date : 2021-04-28, Wednesday

Project	LaBella
Project Code	LaBella
Site Name	33
Legs and Movements	All Processed Legs & Move
Bin Size	15 minutes
Survey Date	2021-11-03, Wednesday
Location	33
Latitude and Longitude	42.911146, -78.853969

	Start	End	PHF
Forced Peak AM	2021/11/03 07:30:00	2021/11/03 08:30:00	0.87
Forced Peak PM	2021/11/03 16:30:00	2021/11/03 17:30:00	0.93
AM Peak	2021/11/03 07:30:00	2021/11/03 08:30:00	0.87
PM Peak	2021/11/03 16:15:00	2021/11/03 17:15:00	0.94

### Turning Movement Data

Leg Direction	Jefferson Ave										E Utica St										Total								
	Southbound					Westbound					Northbound					Eastbound													
	Right	Thru	Left	U-Turn	App Total	Perfs CV	Perfs CCV	Right	Thru	Left	U-Turn	App Total	Perfs CV	Perfs CCV	Right	Thru	Left	U-Turn	App Total	Perfs CV		Perfs CCV							
6:30:00 AM	2	9	2	0	13	0	0	0	5	4	0	9	0	0	2	16	1	0	19	0	0	5	5	0	0	10	1	0	51
6:45:00 AM	1	20	1	0	22	0	0	5	6	0	0	12	0	0	1	15	2	0	18	1	0	2	9	0	0	11	2	0	63
Hourly Total	3	29	3	0	35	0	0	5	11	4	0	21	0	0	3	31	3	0	37	1	0	7	14	0	0	21	3	2	114
7:00:00 AM	3	18	2	0	23	0	0	2	15	3	0	21	1	2	4	35	2	0	44	0	2	5	11	4	0	20	2	1	108
7:15:00 AM	3	29	0	0	32	0	1	4	13	4	0	22	0	1	1	34	4	0	40	0	1	8	7	0	0	15	3	0	109
7:30:00 AM	5	28	1	0	34	0	1	4	17	4	0	26	1	0	2	27	2	0	32	1	1	5	15	2	0	22	2	1	114
7:45:00 AM	6	67	4	0	77	0	1	1	31	4	0	37	0	1	3	25	5	0	34	1	0	5	20	1	0	26	2	0	174
Hourly Total	17	142	7	0	166	0	4	11	76	15	0	106	2	4	10	121	13	0	150	2	4	23	53	7	0	83	9	2	595
8:00:00 AM	3	47	2	0	52	1	1	5	24	7	0	37	1	0	1	40	7	0	49	1	0	10	25	2	0	37	5	3	175
8:15:00 AM	4	30	1	0	35	1	2	1	17	5	0	25	1	0	3	39	6	0	49	2	4	11	23	3	0	37	4	0	146
Hourly Total	7	77	3	0	87	2	3	6	41	12	0	62	2	0	4	79	13	0	98	3	4	21	48	5	0	74	9	3	321
4:00:00 PM	8	55	5	0	68	5	0	11	19	11	0	41	3	2	9	75	6	0	90	2	0	11	38	5	0	54	1	2	263
4:15:00 PM	4	62	2	0	68	0	2	8	24	11	0	43	0	1	13	69	10	0	92	2	3	6	20	3	0	29	4	2	232
4:30:00 PM	4	84	4	0	92	0	0	6	27	9	0	42	0	0	6	64	6	0	76	0	1	11	23	1	0	35	1	2	245
4:45:00 PM	4	47	3	0	54	2	2	7	17	12	0	36	0	4	7	61	10	0	78	2	1	8	19	4	0	31	5	1	199
Hourly Total	20	248	14	0	282	7	4	32	87	43	0	162	3	7	35	299	32	0	336	6	5	36	100	13	0	149	11	7	929
5:00:00 PM	7	64	6	0	77	1	0	9	21	12	0	42	0	0	8	73	9	0	90	1	0	9	34	3	0	36	0	0	245
5:15:00 PM	1	55	3	0	59	2	1	11	21	5	0	37	0	1	12	63	8	0	83	0	1	10	25	6	0	41	3	1	220
5:30:00 PM	1	74	6	0	81	2	2	12	23	9	0	44	1	1	5	61	4	0	70	0	2	7	23	5	0	35	0	2	230
5:45:00 PM	8	54	2	0	64	0	1	5	9	10	0	24	2	0	7	49	9	0	65	0	1	6	12	0	0	18	0	2	171
Hourly Total	17	247	17	0	281	5	4	37	74	36	0	147	3	2	32	246	30	0	308	1	4	32	84	14	0	130	3	5	866
Grand Total	64	743	44	0	851	14	16	91	289	110	0	498	10	13	84	746	91	0	929	13	17	119	299	39	0	457	15	16	2735
% Approach	7.5%	87.3%	6.2%	0.0%	0.0%	0.0%	0.0%	18.3%	58.0%	22.1%	0.0%	0.0%	0.0%	0.0%	9.0%	80.3%	9.8%	0.0%	0.0%	0.0%	0.0%	26.0%	65.4%	8.5%	0.0%	0.0%	0.0%	0.0%	0.0%
% Total	2.3%	27.2%	1.6%	0.0%	31.1%	0.0%	0.0%	3.3%	10.6%	4.0%	0.0%	18.2%	0.0%	0.0%	3.1%	27.3%	3.3%	0.0%	34.0%	0.0%	0.0%	4.4%	10.9%	1.4%	0.0%	16.7%	0.0%	0.0%	0.0%
Lights	60	711	43	0	814	0	0	79	258	105	0	442	0	0	82	713	88	0	883	0	0	111	262	34	0	407	0	0	2546
% Lights	93.8%	95.7%	97.7%	0.0%	95.7%	0.0%	0.0%	86.9%	89.3%	95.5%	0.0%	88.6%	0.0%	0.0%	87.6%	95.6%	96.7%	0.0%	95.0%	0.0%	0.0%	93.3%	87.6%	87.2%	0.0%	89.1%	0.0%	0.0%	93.1%
Trucks	0	2	0	0	2	0	0	0	0	0	0	0	0	0	0	1	0	0	1	0	0	0	1	0	0	1	0	0	4
% Trucks	0.0%	0.3%	0.0%	0.0%	0.2%	0.0%	0.0%	0.0%	0.0%	0.0%	0.0%	0.0%	0.0%	0.0%	0.0%	0.1%	0.0%	0.0%	0.1%	0.0%	0.0%	0.0%	0.3%	0.0%	0.0%	0.2%	0.0%	0.0%	0.1%
Buses	4	30	1	0	35	0	0	12	31	5	0	48	0	0	2	32	3	0	37	0	0	8	36	5	0	49	0	0	169
% Buses	6.3%	4.0%	2.3%	0.0%	0.0%	0.0%	0.0%	0.0%	10.7%	4.5%	0.0%	0.0%	0.0%	0.0%	2.4%	4.3%	3.3%	0.0%	0.0%	0.0%	0.0%	6.7%	12.0%	12.8%	0.0%	0.0%	0.0%	0.0%	6.2%
Pedestrians	0	0	0	0	0	13	16	0	0	0	0	0	9	12	0	0	0	0	0	11	15	0	0	0	0	0	0	33	16
% Pedestrians	0.0%	0.0%	0.0%	0.0%	0.0%	82.8%	100.0%	0.0%	0.0%	0.0%	0.0%	0.0%	90.0%	92.9%	0.0%	0.0%	0.0%	0.0%	0.0%	84.6%	89.2%	0.0%	0.0%	0.0%	0.0%	0.0%	0.0%	84.3%	84.2%
Bicycles on Crosswalk	0	0	0	0	0	1	0	0	0	0	0	0	1	1	0	0	0	0	0	2	2	0	0	0	0	0	0	2	3
% Bicycles on Crosswalk	0.0%	0.0%	0.0%	0.0%	0.0%	7.1%	0.0%	0.0%	0.0%	0.0%	0.0%	0.0%	10.0%	7.7%	0.0%	0.0%	0.0%	0.0%	0.0%	15.4%	11.8%	0.0%	0.0%	0.0%	0.0%	0.0%	0.0%	5.7%	15.8%

Project : VBH Malta NY  
 Site : Site 4  
 Location : 42.948550, -73.790036  
 Survey Date : 2021-04-28, Wednesday

### Turning Movement Data Plot

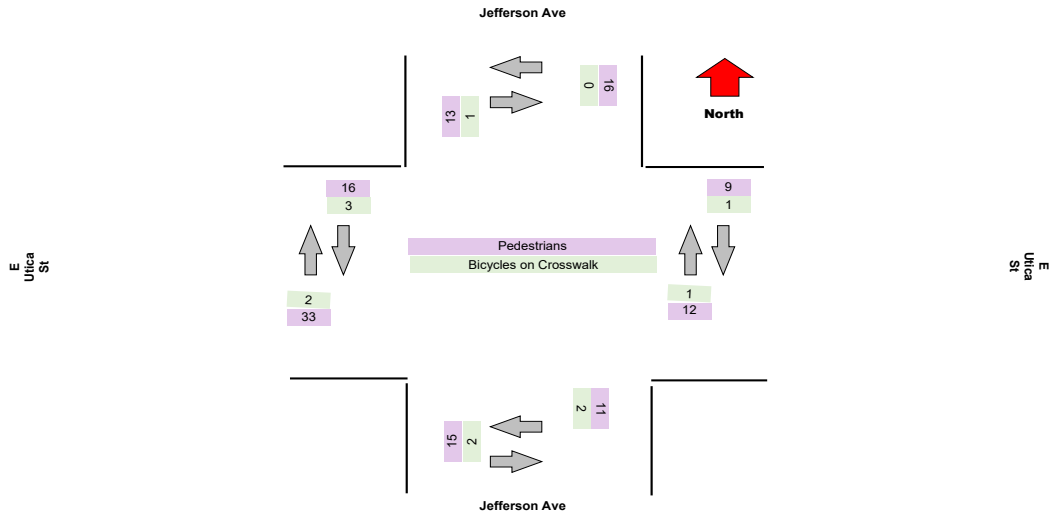
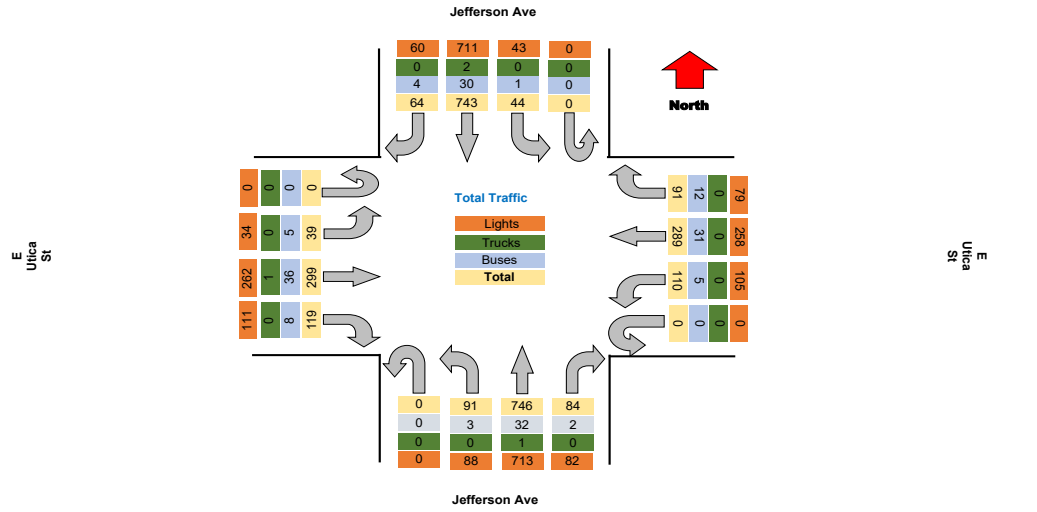

Project : VBH Malta NY  
Site : Site 4  
Location : 42.948550, -73.790036  
Survey Date : 2021-04-28, Wednesday

TSTData.com

**Turning Movement Peak Hour Data (AM)**

7:30:00 AM

Leg Direction	Jefferson Ave					E Ullica St					Jefferson Ave					E Ullica St					Total									
	Right	Thru	Left	U-Turn	App Total	Peds CW	Peds CCW	Right	Thru	Left	U-Turn	App Total	Peds CW	Peds CCW	Right	Thru	Left	U-Turn	App Total	Peds CW		Peds CCW								
7:30:00 AM	5	28	1	0	34	0	1	4	17	4	0	26	1	0	2	27	2	0	32	1	1	5	15	2	0	22	2	1	114	
7:45:00 AM	6	67	4	0	77	0	1	1	31	4	0	37	0	1	3	25	5	0	34	1	0	5	20	1	0	26	2	0	174	
8:00:00 AM	3	47	2	0	52	1	1	5	24	7	0	37	1	0	1	40	7	0	49	1	0	10	25	2	0	37	5	3	175	
8:15:00 AM	4	30	1	0	35	1	0	1	17	5	0	25	1	0	3	39	6	0	49	2	0	11	23	3	0	37	4	0	146	
<b>Grand Total</b>	<b>18</b>	<b>172</b>	<b>8</b>	<b>0</b>	<b>198</b>	<b>2</b>	<b>3</b>	<b>11</b>	<b>89</b>	<b>20</b>	<b>0</b>	<b>125</b>	<b>3</b>	<b>1</b>	<b>9</b>	<b>131</b>	<b>20</b>	<b>0</b>	<b>164</b>	<b>3</b>	<b>1</b>	<b>31</b>	<b>83</b>	<b>8</b>	<b>0</b>	<b>122</b>	<b>13</b>	<b>4</b>	<b>689</b>	
% Approach	9.1%	86.9%	4.0%	0.0%	0.0%	0.0%	0.0%	8.8%	71.2%	16.0%	0.0%	0.0%	0.0%	0.0%	5.5%	79.9%	12.2%	0.0%	0.0%	0.0%	0.0%	25.4%	66.0%	6.6%	0.0%	0.0%	0.0%	0.0%	0.0%	
% Total	3.0%	28.2%	1.3%	0.0%	32.5%	0.0%	0.0%	1.8%	14.6%	3.3%	0.0%	20.5%	0.0%	0.0%	1.5%	21.5%	3.3%	0.0%	26.9%	0.0%	0.0%	5.1%	13.6%	1.3%	0.0%	20.0%	0.0%	0.0%	0.0%	
PHF	0.750	0.642	0.500	0.000	0.643	0.000	0.000	0.550	0.718	0.714	0.000	0.845	0.000	0.000	0.750	0.819	0.714	0.000	0.837	0.000	0.000	0.705	0.830	0.667	0.000	0.824	0.000	0.000	0.870	
Lights	17	164	7	0	188	0	0	9	79	17	0	105	0	0	8	119	18	0	145	0	0	28	68	8	0	104	0	0	542	
% Lights	84.4%	85.3%	87.5%	0.0%	94.9%	0.0%	0.0%	81.8%	88.8%	85.0%	0.0%	84.0%	0.0%	0.0%	88.9%	90.8%	90.0%	0.0%	88.4%	0.0%	0.0%	90.3%	81.9%	100.0%	0.0%	85.2%	0.0%	0.0%	89.0%	
Trucks	0	1	0	0	1	0	0	0	0	0	0	0	0	0	0	0	0	0	0	0	0	0	0	0	0	0	0	0	1	
% Trucks	0.0%	0.6%	0.0%	0.0%	0.5%	0.0%	0.0%	0.0%	0.0%	0.0%	0.0%	0.0%	0.0%	0.0%	0.0%	0.0%	0.0%	0.0%	0.0%	0.0%	0.0%	0.0%	0.0%	0.0%	0.0%	0.0%	0.0%	0.0%	0.2%	
Buses	1	7	1	0	9	0	0	2	10	3	0	15	0	0	1	12	2	0	15	0	0	3	15	0	0	18	0	0	57	
% Buses	5.6%	4.1%	12.5%	0.0%	0.0%	0.0%	0.0%	18.2%	11.2%	15.0%	0.0%	0.0%	0.0%	0.0%	11.1%	9.2%	10.0%	0.0%	0.0%	0.0%	0.0%	9.7%	18.1%	0.0%	0.0%	0.0%	0.0%	0.0%	9.4%	
Pedestrians	0	0	0	0	0	2	5	0	0	0	0	0	2	1	0	0	0	0	0	4	4	0	0	0	0	0	11	3	0	
% Pedestrians	0.0%	0.0%	0.0%	0.0%	0.0%	100.0%	100.0%	0.0%	0.0%	0.0%	0.0%	0.0%	66.7%	100.0%	0.0%	0.0%	0.0%	0.0%	0.0%	0.0%	80.0%	80.0%	0.0%	0.0%	0.0%	0.0%	0.0%	84.9%	75.0%	0.0%
Bicycles on Crosswalk	0	0	0	0	0	0	0	0	0	0	0	1	0	0	0	0	0	0	1	1	0	0	0	0	0	0	2	1	0	
% Bicycles on Crosswalk	0.0%	0.0%	0.0%	0.0%	0.0%	0.0%	0.0%	0.0%	0.0%	0.0%	0.0%	0.0%	33.3%	0.0%	0.0%	0.0%	0.0%	0.0%	0.0%	20.0%	20.0%	0.0%	0.0%	0.0%	0.0%	0.0%	15.4%	25.0%	0.0%	

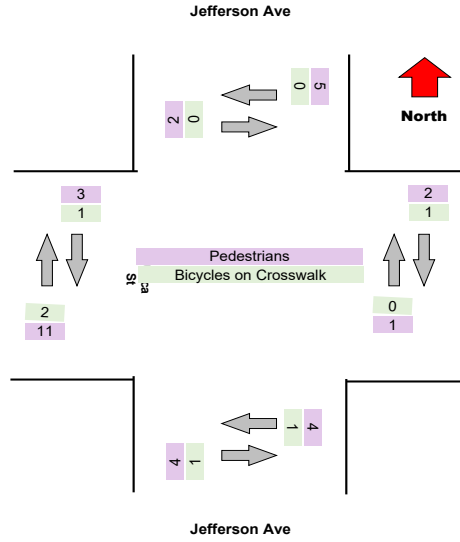
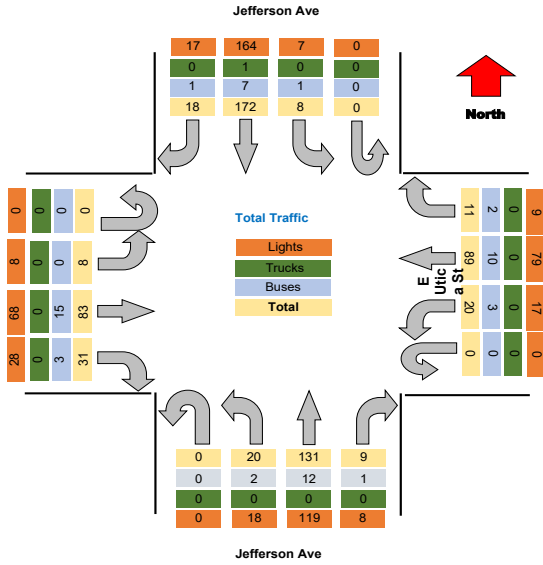

**Turning Movement Peak Hour Data (PM)**

4:15:00 PM

Leg Direction	Jefferson Ave										E Ulica St										Jefferson Ave										E Ulica St										Total
	Southbound					Westbound					Northbound					Eastbound																									
	Right	Thru	Left	U-Turn	App Total	Right	Thru	Left	U-Turn	App Total	Right	Thru	Left	U-Turn	App Total	Right	Thru	Left	U-Turn	App Total																					
4:15:00 PM	4	62	2	0	68	8	24	11	0	43	13	69	10	0	92	6	20	3	0	29																					
4:30:00 PM	4	84	4	0	92	6	27	9	0	42	6	64	6	0	76	11	23	1	0	35																					
4:45:00 PM	4	47	3	0	54	7	17	12	0	36	7	61	10	0	78	8	19	4	0	31																					
5:00:00 PM	7	64	6	0	77	9	21	12	0	42	8	73	9	0	90	9	24	3	0	36																					
<b>Grand Total</b>	<b>19</b>	<b>257</b>	<b>15</b>	<b>0</b>	<b>291</b>	<b>30</b>	<b>89</b>	<b>44</b>	<b>0</b>	<b>163</b>	<b>34</b>	<b>297</b>	<b>35</b>	<b>0</b>	<b>366</b>	<b>34</b>	<b>86</b>	<b>11</b>	<b>0</b>	<b>131</b>																					
% Approach	6.5%	88.3%	5.2%	0.0%	0.0%	18.4%	54.6%	27.0%	0.0%	0.0%	10.1%	79.5%	10.4%	0.0%	0.0%	26.0%	65.6%	8.4%	0.0%	0.0%																					
% Total	2.1%	27.9%	1.6%	0.0%	31.6%	3.3%	9.7%	4.8%	0.0%	17.7%	3.7%	29.0%	3.8%	0.0%	36.5%	3.7%	9.3%	1.2%	0.0%	14.2%																					
PHF	0.679	0.765	0.625	0.000	0.791	0.833	0.824	0.917	0.000	0.948	0.654	0.914	0.875	0.000	0.813	0.773	0.886	0.688	0.000	0.910																					
Lights	19	246	15	0	280	24	80	43	0	147	34	261	34	0	329	32	78	11	0	121																					
% Lights	100.0%	95.7%	100.0%	0.0%	96.2%	80.0%	89.9%	97.7%	0.0%	90.2%	100.0%	97.8%	97.1%	0.0%	97.9%	94.1%	90.7%	100.0%	0.0%	92.4%																					
Trucks	0	0	0	0	0	0	0	0	0	0	0	0	0	0	0	0	1	0	0	1																					
% Trucks	0.0%	0.0%	0.0%	0.0%	0.0%	0.0%	0.0%	0.0%	0.0%	0.0%	0.0%	0.0%	0.0%	0.0%	0.0%	0.0%	1.2%	0.0%	0.0%	0.8%																					
Buses	0	11	0	0	11	6	9	1	0	16	0	6	1	0	7	2	7	0	0	9																					
% Buses	0.0%	4.3%	0.0%	0.0%	0.0%	20.0%	10.1%	2.3%	0.0%	0.0%	0.0%	2.2%	2.9%	0.0%	0.0%	5.9%	8.1%	0.0%	0.0%	0.0%																					
Pedestrians	0	0	0	0	0	3	4	0	0	7	5	0	0	0	5	0	0	0	0	0																					
% Pedestrians	0.0%	0.0%	0.0%	0.0%	0.0%	100.0%	100.0%	0.0%	0.0%	80.0%	0.0%	0.0%	0.0%	0.0%	0.0%	0.0%	0.0%	0.0%	0.0%	0.0%																					
Bicycles on Crosswalk	0	0	0	0	0	0	0	0	0	0	1	0	0	0	1	0	0	0	0	0																					
% Bicycles on Crosswalk	0.0%	0.0%	0.0%	0.0%	0.0%	0.0%	0.0%	0.0%	0.0%	0.0%	0.0%	0.0%	0.0%	0.0%	0.0%	0.0%	0.0%	0.0%	0.0%	0.0%																					

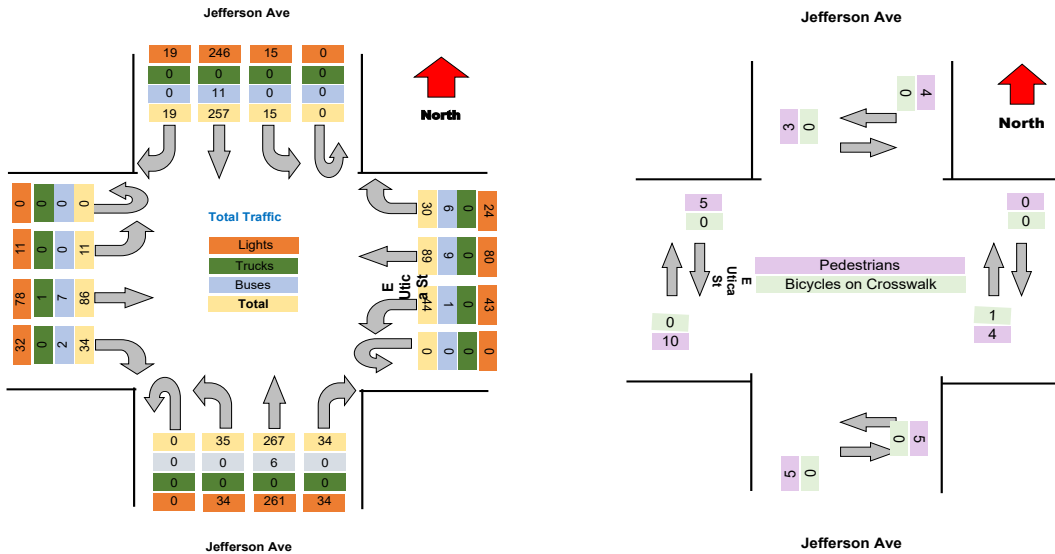

Project : VBH Malta NY  
 Site : Site 4  
 Location : 42.948550, -73.790036

TSTData.com

Survey Date : 2021-04-28, Wednesday

Project	LaBella
Project Code	LaBella
Site Name	33
Legs and Movements	All Processed Legs & Move
Bin Size	15 minutes
Survey Date	2021-11-04, Thursday
Location	33
Latitude and Longitude	42.911146, -78.853969

	Start	End	PHF
Forced Peak AM	2021/11/04 07:30:00	2021/11/04 08:30:00	0.89
Forced Peak PM	2021/11/04 16:30:00	2021/11/04 17:30:00	0.85
AM Peak	2021/11/04 07:30:00	2021/11/04 08:30:00	0.89
PM Peak	2021/11/04 16:15:00	2021/11/04 17:15:00	0.88

### Turning Movement Data

Leg Direction	Jefferson Ave Southbound					E Utica St Westbound					Jefferson Ave Northbound					E Utica St Eastbound					Total				
	Right	Thru	Left	U-Turn	App Total	Right	Thru	Left	U-Turn	App Total	Right	Thru	Left	U-Turn	App Total	Right	Thru	Left	U-Turn	App Total					
6:30:00 AM	1	11	0	0	12	0	7	1	0	8	0	11	5	0	17	0	2	4	2	0	8				
6:45:00 AM	2	14	2	0	18	1	7	0	0	8	1	24	3	0	28	0	2	8	1	0	11				
Hourly Total	3	25	2	0	30	1	14	1	0	17	1	35	8	0	45	0	4	12	3	0	19				
7:00:00 AM	2	9	0	0	11	3	12	5	0	20	4	20	7	0	33	2	11	3	0	16					
7:15:00 AM	3	24	1	0	28	2	22	5	0	29	2	29	5	0	36	2	9	8	2	0	19				
7:30:00 AM	6	34	0	0	40	2	27	4	0	33	0	1	21	5	0	27	0	3	18	2	0	23			
7:45:00 AM	5	35	5	0	45	2	28	7	0	38	1	5	34	4	0	44	0	5	16	2	0	23			
Hourly Total	16	102	6	0	124	9	89	21	0	120	3	12	104	21	0	140	3	19	53	9	0	81			
8:00:00 AM	8	41	2	0	49	3	20	6	0	30	2	6	39	4	0	53	2	7	19	4	0	30			
8:15:00 AM	1	40	0	0	41	2	15	2	0	20	1	1	41	6	0	50	0	9	14	5	0	28			
Hourly Total	7	81	2	0	90	5	35	8	0	50	3	7	80	10	0	103	2	16	33	9	0	58			
4:00:00 PM	1	60	5	0	66	13	18	10	0	41	3	11	60	8	0	79	2	10	24	3	0	37			
4:15:00 PM	3	69	3	0	75	6	25	10	0	41	4	9	60	12	0	81	0	6	24	8	0	38			
4:30:00 PM	2	51	3	0	56	6	15	10	0	31	1	0	12	49	10	71	0	7	26	3	0	36			
4:45:00 PM	10	59	1	0	70	13	25	13	0	51	0	16	68	9	0	83	1	10	26	6	0	42			
Hourly Total	16	239	12	0	267	38	83	43	0	164	8	48	237	39	0	324	3	33	100	20	0	153			
5:00:00 PM	9	67	5	0	71	9	27	8	0	44	2	3	60	9	0	72	1	4	21	7	0	32			
5:15:00 PM	4	54	0	0	58	8	19	10	0	37	0	2	8	53	15	76	0	9	24	2	0	35			
5:30:00 PM	4	60	1	0	65	10	15	11	0	36	0	1	5	52	7	64	0	14	19	4	0	37			
5:45:00 PM	4	50	2	0	56	10	25	7	0	42	0	6	51	7	0	64	0	5	17	0	0	22			
Hourly Total	21	221	8	0	250	37	86	36	0	159	2	22	216	38	0	276	1	32	81	13	0	126			
Grand Total	63	668	30	0	761	90	307	109	0	510	14	90	672	116	0	888	14	104	279	54	0	437			
% Approach	8.3%	87.8%	3.9%	0.0%	0.0%	17.6%	60.2%	21.4%	0.0%	0.0%	10.1%	75.7%	13.1%	0.0%	0.0%	23.8%	63.8%	12.4%	0.0%	0.0%	0.0%	0.0%	0.0%	0.0%	0.0%
% Total	2.4%	25.7%	1.2%	0.0%	29.3%	3.5%	11.8%	4.2%	0.0%	19.6%	3.5%	25.9%	4.5%	0.0%	34.2%	4.0%	10.7%	2.1%	0.0%	16.8%	0.0%	0.0%	0.0%	0.0%	0.0%
Lights	60	639	29	0	728	81	277	105	0	463	0	82	639	112	0	833	0	97	249	50	0	396			
% Lights	95.2%	95.7%	96.3%	0.0%	95.7%	90.0%	90.2%	96.3%	0.0%	90.8%	0.0%	81.1%	95.1%	96.6%	0.0%	93.8%	0.0%	93.3%	89.2%	92.6%	0.0%	90.6%			
Trucks	0	0	0	0	0	0	0	0	0	0	0	3	0	0	3	0	0	0	0	0	0				
% Trucks	0.0%	0.0%	0.0%	0.0%	0.0%	0.0%	0.0%	0.0%	0.0%	0.0%	0.0%	0.4%	0.0%	0.0%	0.3%	0.0%	0.0%	0.0%	0.0%	0.0%	0.0%				
Buses	3	28	1	0	32	9	30	4	0	43	0	8	28	4	0	40	0	7	30	4	0	41			
% Buses	4.8%	4.2%	3.3%	0.0%	0.0%	0.0%	9.8%	3.7%	0.0%	0.0%	0.0%	8.9%	4.2%	3.4%	0.0%	0.0%	0.0%	6.7%	10.8%	7.4%	0.0%	0.0%			
Pedestrians	0	0	0	0	0	0	0	0	0	0	0	0	0	0	0	0	0	0	0	0	0				
% Pedestrians	0.0%	0.0%	0.0%	0.0%	0.0%	0.0%	0.0%	0.0%	0.0%	0.0%	0.0%	0.0%	0.0%	0.0%	0.0%	0.0%	0.0%	0.0%	0.0%	0.0%	0.0%				
Bicycles on Crosswalk	0	0	0	0	0	0	0	0	0	0	0	0	0	0	0	0	0	0	0	0	0				
% Bicycles on Crosswalk	0.0%	0.0%	0.0%	0.0%	0.0%	0.0%	0.0%	0.0%	0.0%	0.0%	0.0%	0.0%	0.0%	0.0%	0.0%	0.0%	0.0%	0.0%	0.0%	0.0%	0.0%				

Project : VBH Malta NY  
 Site : Site 4  
 Location : 42.948550, -73.790036  
 Survey Date : 2021-04-28, Wednesday

**Turning Movement Data Plot**

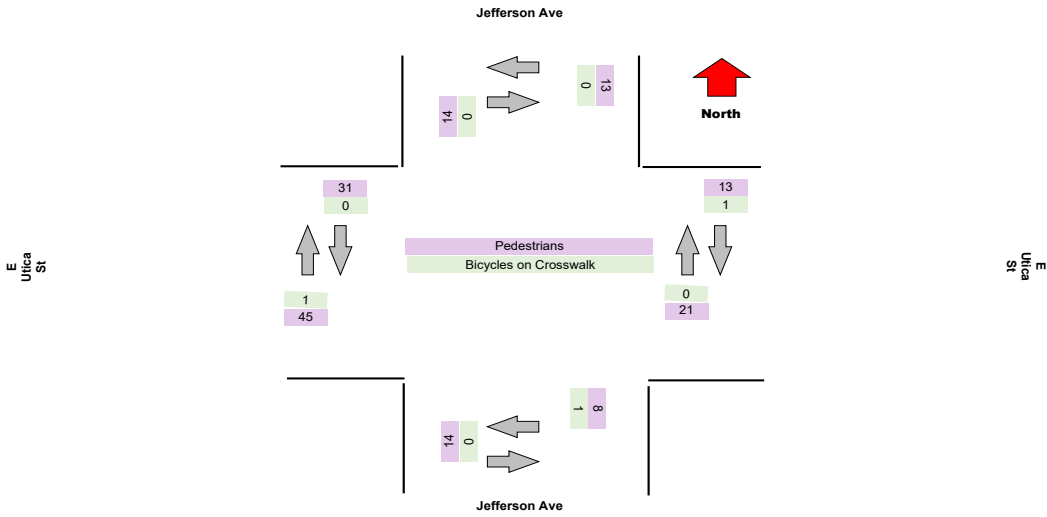
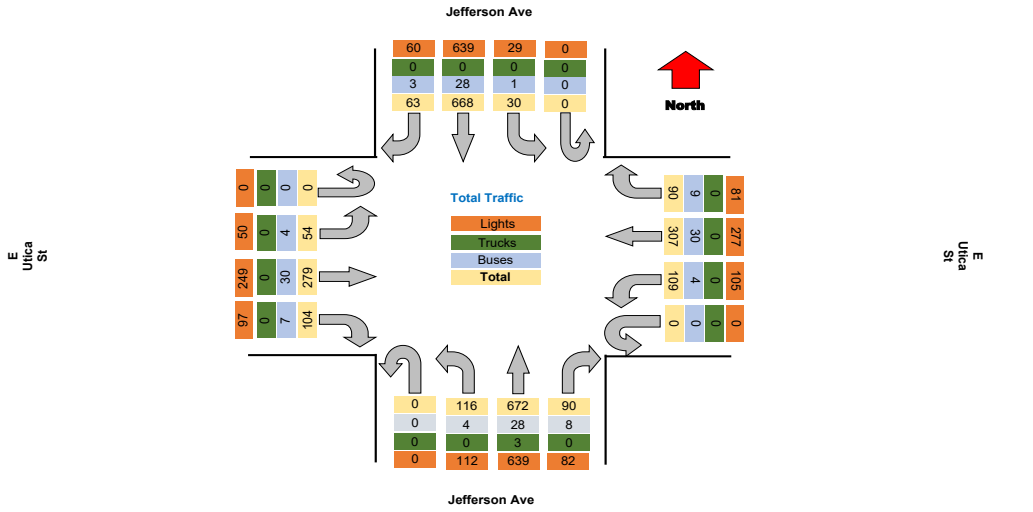



Project : VBH Malta NY  
Site : Site 4  
Location : 42.948550, -73.790036

TSTData.com

Survey Date : 2021-04-28, Wednesday

### Turning Movement Peak Hour Data (AM)

7:30:00 AM

Leg Direction	Jefferson Ave					E Ulrica St					Jefferson Ave					E Ulrica St					Total									
	Southbound					Westbound					Northbound					Eastbound														
Start Time	Right	Thru	Left	U-Turn	App Total	Peds CW	Peds CCW	Right	Thru	Left	U-Turn	App Total	Peds CW	Peds CCW	Right	Thru	Left	U-Turn	App Total	Peds CW	Peds CCW	Right	Thru	Left	U-Turn	App Total	Peds CW	Peds CCW		
7:30:00 AM	6	34	0	0	40	0	0	2	27	4	0	33	0	0	1	21	5	0	27	0	0	3	18	2	0	23	2	0	123	
7:45:00 AM	5	35	5	0	45	1	1	2	28	7	0	38	0	1	5	34	4	0	44	0	1	5	16	2	0	23	0	1	160	
8:00:00 AM	6	41	2	0	49	0	1	3	20	6	0	30	2	2	6	39	4	0	53	2	1	7	19	4	0	30	6	5	162	
8:15:00 AM	1	40	0	0	41	1	1	2	15	2	0	20	1	1	1	41	6	0	50	0	0	9	14	5	0	28	4	2	139	
Grand Total	18	150	7	0	175	2	3	9	90	19	0	121	3	4	13	135	19	0	174	2	2	24	67	13	0	104	12	8	674	
% Approach	10.3%	85.7%	4.0%	0.0%	0.0%	0.0%	0.0%	7.4%	74.4%	15.7%	0.0%	0.0%	0.0%	0.0%	7.5%	77.6%	10.9%	0.0%	0.0%	0.0%	0.0%	23.1%	64.4%	12.5%	0.0%	0.0%	0.0%	0.0%	0.0%	
% Total	3.1%	26.1%	1.2%	0.0%	30.6%	0.0%	0.0%	1.6%	15.7%	3.3%	0.0%	21.1%	0.0%	0.0%	2.3%	23.5%	3.3%	0.0%	30.3%	0.0%	0.0%	4.2%	11.7%	2.3%	0.0%	18.1%	0.0%	0.0%	0.0%	
PHF	0.750	0.915	0.350	0.000	0.893	0.000	0.000	0.750	0.804	0.679	0.000	0.796	0.000	0.000	0.542	0.823	0.792	0.000	0.821	0.000	0.000	0.667	0.882	0.650	0.000	0.867	0.000	0.000	0.886	
Lights	17	144	6	0	167	0	0	7	80	17	0	104	0	0	9	121	18	0	148	0	0	22	54	13	0	89	0	0	508	
% Lights	84.4%	96.0%	85.7%	0.0%	95.4%	0.0%	0.0%	77.8%	88.9%	89.5%	0.0%	86.0%	0.0%	0.0%	69.2%	89.6%	94.7%	0.0%	85.1%	0.0%	0.0%	91.7%	80.6%	100.0%	0.0%	85.6%	0.0%	0.0%	88.6%	
Trucks	0	0	0	0	0	0	0	0	0	0	0	0	0	0	0	2	0	0	2	0	0	0	0	0	0	0	0	0	2	
% Trucks	0.0%	0.0%	0.0%	0.0%	0.0%	0.0%	0.0%	0.0%	0.0%	0.0%	0.0%	0.0%	0.0%	0.0%	0.0%	1.5%	0.0%	0.0%	1.1%	0.0%	0.0%	0.0%	0.0%	0.0%	0.0%	0.0%	0.0%	0.0%	0.3%	
Buses	1	6	1	0	8	0	0	2	10	2	0	14	0	0	4	12	1	0	17	0	0	2	13	0	0	15	0	0	54	
% Buses	5.6%	4.0%	14.3%	0.0%	0.0%	0.0%	0.0%	22.2%	11.1%	10.5%	0.0%	0.0%	0.0%	0.0%	30.8%	8.9%	5.3%	0.0%	0.0%	0.0%	0.0%	8.3%	19.4%	0.0%	0.0%	0.0%	0.0%	0.0%	9.4%	
Pedestrians	0	0	0	0	0	2	3	0	0	0	0	3	4	0	0	0	0	0	0	2	2	0	0	0	0	0	11	8	0	
% Pedestrians	0.0%	0.0%	0.0%	0.0%	0.0%	100.0%	100.0%	0.0%	0.0%	0.0%	0.0%	0.0%	100.0%	100.0%	0.0%	0.0%	0.0%	0.0%	0.0%	0.0%	100.0%	100.0%	0.0%	0.0%	0.0%	0.0%	0.0%	91.7%	100.0%	0.0%
Bicycles on Crosswalk	0	0	0	0	0	0	0	0	0	0	0	0	0	0	0	0	0	0	0	0	0	0	0	0	0	0	0	1	0	
% Bicycles on Crosswalk	0.0%	0.0%	0.0%	0.0%	0.0%	0.0%	0.0%	0.0%	0.0%	0.0%	0.0%	0.0%	0.0%	0.0%	0.0%	0.0%	0.0%	0.0%	0.0%	0.0%	0.0%	0.0%	0.0%	0.0%	0.0%	0.0%	0.0%	8.3%	0.0%	0.0%

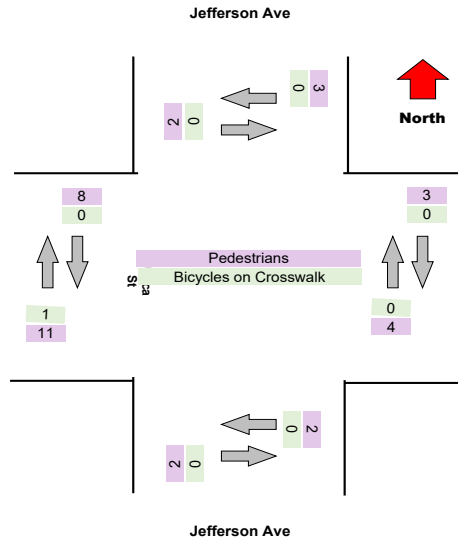
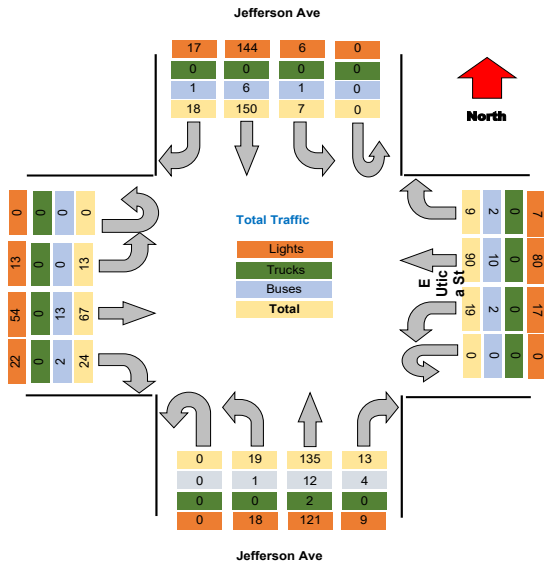

Project : VBH Malta NY  
Site : Site 4  
Location : 42.948550, -73.790036

TSTData.com

Survey Date : 2021-04-28, Wednesday

### Turning Movement Peak Hour Data (PM)

4:15:00 PM

Leg Direction	Jefferson Ave								E Ulica St								Jefferson Ave								E Ulica St								Total
	Southbound				Westbound				Northbound				Eastbound				Southbound				Westbound				Northbound				Eastbound				
	Right	Thru	Left	U-Turn	App Total	Peds CW	Peds CCW		Right	Thru	Left	U-Turn	App Total	Peds CW	Peds CCW		Right	Thru	Left	U-Turn	App Total	Peds CW	Peds CCW		Right	Thru	Left	U-Turn	App Total	Peds CW	Peds CCW		
4:15:00 PM	3	69	3	0	75	4	1		6	25	10	0	41	4	3		9	60	12	0	81	0	1		6	24	8	0	38	7	4		235
4:30:00 PM	2	51	3	0	56	0	1		6	15	10	0	31	1	0		12	49	10	0	71	0	3		7	26	3	0	36	2	8		194
4:45:00 PM	10	59	1	0	70	4	2		13	25	13	0	51	0	4		16	68	9	0	93	1	0		10	26	6	0	42	3	2		256
5:00:00 PM	9	57	5	0	71	4	1		9	27	8	0	44	2	1		3	50	8	0	72	1	1		4	21	7	0	32	4	1		219
<b>Grand Total</b>	<b>24</b>	<b>236</b>	<b>12</b>	<b>0</b>	<b>272</b>	<b>8</b>	<b>5</b>		<b>34</b>	<b>92</b>	<b>41</b>	<b>0</b>	<b>157</b>	<b>7</b>	<b>8</b>		<b>40</b>	<b>237</b>	<b>40</b>	<b>0</b>	<b>317</b>	<b>2</b>	<b>5</b>		<b>27</b>	<b>87</b>	<b>24</b>	<b>0</b>	<b>148</b>	<b>15</b>	<b>15</b>		<b>904</b>
% Approach	8.8%	86.8%	4.4%	0.0%	0.0%	0.0%	0.0%		20.4%	55.1%	24.6%	0.0%	0.0%	0.0%	0.0%		12.6%	74.8%	12.6%	0.0%	0.0%	0.0%	0.0%		18.2%	65.5%	16.2%	0.0%	0.0%	0.0%	0.0%		
% Total	2.7%	26.1%	1.3%	0.0%	30.1%	0.0%	0.0%		3.8%	10.2%	4.5%	0.0%	18.5%	0.0%	0.0%		4.4%	26.2%	4.4%	0.0%	35.1%	0.0%	0.0%		3.0%	10.7%	2.7%	0.0%	16.4%	0.0%	0.0%		
PHF	0.600	0.855	0.600	0.000	0.907	0.000	0.000		0.654	0.852	0.788	0.000	0.819	0.000	0.000		0.625	0.871	0.833	0.000	0.852	0.000	0.000		0.675	0.933	0.750	0.000	0.881	0.000	0.000		0.883
Lights	24	226	12	0	262	0	0		29	83	41	0	153	0	0		39	229	38	0	306	0	0		26	93	24	0	143	0	0		864
% Lights	100.0%	95.8%	100.0%	0.0%	96.3%	0.0%	0.0%		85.3%	90.2%	100.0%	0.0%	91.6%	0.0%	0.0%		97.5%	96.6%	95.0%	0.0%	96.5%	0.0%	0.0%		96.3%	95.9%	100.0%	0.0%	96.6%	0.0%	0.0%		95.6%
Trucks	0	0	0	0	0	0	0		0	0	0	0	0	0	0		0	0	0	0	0	0	0		0	0	0	0	0	0	0		0
% Trucks	0.0%	0.0%	0.0%	0.0%	0.0%	0.0%	0.0%		0.0%	0.0%	0.0%	0.0%	0.0%	0.0%	0.0%		0.0%	0.0%	0.0%	0.0%	0.0%	0.0%	0.0%		0.0%	0.0%	0.0%	0.0%	0.0%	0.0%	0.0%		0.0%
Buses	0	10	0	0	10	0	0		5	9	0	0	14	0	0		1	7	2	0	10	0	0		1	4	0	0	5	0	0		39
% Buses	0.0%	4.2%	0.0%	0.0%	0.0%	0.0%	0.0%		14.7%	9.8%	0.0%	0.0%	0.0%	0.0%	0.0%		2.5%	3.0%	5.0%	0.0%	0.0%	0.0%	0.0%		3.7%	4.1%	0.0%	0.0%	0.0%	0.0%	0.0%		4.3%
Pedestrians	0	0	0	0	0	9	5		0	0	0	0	6	6	8		0	0	0	0	1	5	1		0	0	0	0	0	16	15		0
% Pedestrians	0.0%	0.0%	0.0%	0.0%	0.0%	100.0%	100.0%		0.0%	0.0%	0.0%	0.0%	0.0%	85.7%	100.0%		0.0%	0.0%	0.0%	0.0%	0.0%	50.0%	100.0%		0.0%	0.0%	0.0%	0.0%	0.0%	100.0%	100.0%		0.0%
Bicycles on Crosswalk	0	0	0	0	0	0	0		0	0	0	0	1	0	0		0	0	0	0	1	0	0		0	0	0	0	0	0	0		0
% Bicycles on Crosswalk	0.0%	0.0%	0.0%	0.0%	0.0%	0.0%	0.0%		0.0%	0.0%	0.0%	0.0%	0.0%	14.3%	0.0%		0.0%	0.0%	0.0%	0.0%	0.0%	50.0%	0.0%		0.0%	0.0%	0.0%	0.0%	0.0%	0.0%	0.0%		0.0%

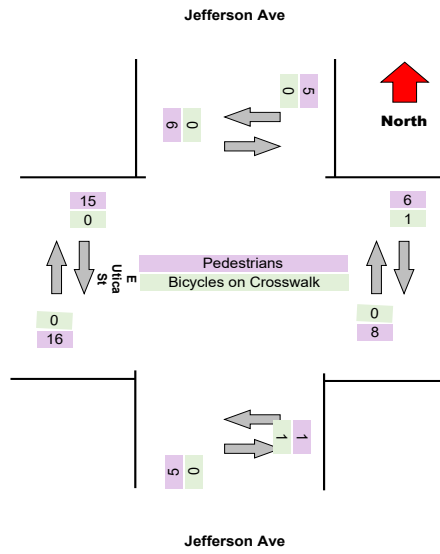
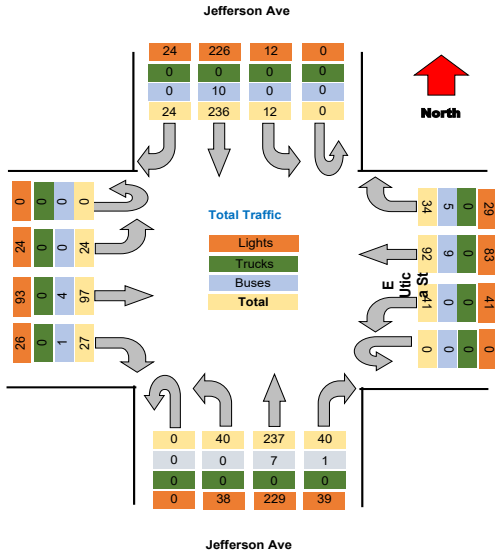

Project : VBH Malta NY  
Site : Site 4  
Location : 42.948550, -73.790036

TSTData.com

Survey Date : 2021-04-28, Wednesday

Project	LaBella
Project Code	LaBella
Site Name	33
Legs and Movements	All Processed Legs & Move
Bin Size	15 minutes
Survey Date	2021-11-02, Tuesday
Location	33
Latitude and Longitude	42.911146, -78.853969

	Start	End	PHF
Forced Peak AM	2021/11/02 07:30:00	2021/11/02 08:30:00	0.85
Forced Peak PM	2021/11/02 16:30:00	2021/11/02 17:30:00	0.85
AM Peak	2021/11/02 07:30:00	2021/11/02 08:30:00	0.85
PM Peak	2021/11/02 16:15:00	2021/11/02 17:15:00	0.93

### Turning Movement Data

Leg Direction	Jefferson Ave					E Utica St					Jefferson Ave					E Utica St					Total				
	Right	Thru	Left	U-Turn	App Total	Right	Thru	Left	U-Turn	App Total	Right	Thru	Left	U-Turn	App Total	Right	Thru	Left	U-Turn	App Total					
6:30:00 AM	0	7	2	0	9	2	4	3	0	10	1	12	3	0	17	4	6	1	0	11	1	0	0	0	1
6:45:00 AM	2	18	3	0	23	3	17	1	0	21	2	21	2	0	25	1	5	0	0	6	4	0	0	0	4
Hourly Total	2	25	5	0	32	5	21	4	0	31	3	33	5	0	42	5	11	1	0	17	5	0	0	0	122
7:00:00 AM	2	13	1	0	16	2	11	6	0	20	1	31	2	0	34	4	13	4	0	21	1	1	1	0	3
7:15:00 AM	1	25	0	0	26	6	8	4	0	20	0	24	3	0	27	6	7	1	0	14	1	1	1	0	3
7:30:00 AM	1	24	2	0	27	7	5	4	0	16	1	24	4	0	31	1	10	2	0	13	4	2	2	0	8
7:45:00 AM	3	22	4	0	29	1	18	1	0	20	4	20	3	0	27	4	6	1	0	11	3	2	2	0	8
Hourly Total	7	84	7	0	98	16	42	15	0	76	6	99	12	0	119	15	36	8	0	59	9	6	6	0	352
8:00:00 AM	2	25	1	0	28	5	20	2	0	27	5	21	8	0	36	7	15	1	0	23	7	5	5	0	17
8:15:00 AM	5	32	2	0	39	2	15	4	0	22	4	20	2	0	26	3	9	0	0	12	2	1	1	0	4
Hourly Total	7	57	3	0	67	7	35	6	0	49	9	41	10	0	61	10	24	1	0	35	9	6	6	0	31
4:00:00 PM	3	55	8	0	66	7	18	6	0	31	6	70	4	0	80	6	28	6	0	40	4	2	2	0	8
4:15:00 PM	7	55	4	0	66	11	19	7	0	37	5	58	4	0	67	11	20	3	0	34	1	1	1	0	3
4:30:00 PM	4	75	5	0	84	12	22	13	0	47	9	58	8	0	75	5	26	7	0	38	2	4	4	0	10
4:45:00 PM	7	53	5	0	65	8	22	7	0	37	9	67	8	0	84	9	27	3	0	39	4	9	9	0	21
Hourly Total	21	238	22	0	281	38	81	33	0	152	29	253	24	0	306	31	101	19	0	151	11	16	16	0	43
5:00:00 PM	2	63	4	0	69	9	28	9	0	44	17	64	7	0	88	9	21	4	0	34	4	2	2	0	8
5:15:00 PM	9	71	4	0	84	7	18	8	0	33	10	60	4	0	74	6	26	3	0	35	1	1	1	0	3
5:30:00 PM	10	42	5	0	57	5	16	8	0	29	9	57	5	0	71	8	22	3	0	33	3	1	1	0	5
5:45:00 PM	2	53	3	0	58	11	12	9	0	32	8	59	10	0	77	5	14	2	0	21	1	1	1	0	3
Hourly Total	23	229	16	0	268	32	72	34	0	138	44	240	26	0	310	28	83	12	0	123	9	5	5	0	19
Grand Total	60	633	53	0	746	98	251	92	0	446	91	666	77	0	838	89	255	41	0	385	43	33	33	0	119
% Approach	8.0%	84.9%	7.1%	0.0%	0.0%	22.0%	56.3%	20.6%	0.0%	0.0%	10.9%	79.5%	9.2%	0.0%	0.0%	23.1%	66.2%	10.6%	0.0%	0.0%	0.0%	0.0%	0.0%	0.0%	0.0%
% Total	2.5%	26.2%	2.2%	0.0%	30.9%	4.1%	10.4%	3.8%	0.0%	18.5%	3.8%	27.6%	3.2%	0.0%	34.7%	3.7%	10.6%	1.7%	0.0%	15.9%	0.0%	0.0%	0.0%	0.0%	0.0%
Lights	59	619	51	0	729	97	236	92	0	425	87	655	75	0	817	89	240	40	0	369	0	0	0	0	2340
% Lights	98.3%	97.8%	98.2%	0.0%	97.7%	99.0%	94.0%	100.0%	0.0%	95.3%	95.0%	98.3%	97.4%	0.0%	97.5%	100.0%	94.1%	97.6%	0.0%	95.8%	0.0%	0.0%	0.0%	0.0%	96.9%
Trucks	0	2	0	0	2	0	0	0	0	0	0	0	0	0	0	0	0	0	0	0	0	0	0	0	2
% Trucks	0.0%	0.3%	0.0%	0.0%	0.3%	0.0%	0.0%	0.0%	0.0%	0.0%	0.0%	0.0%	0.0%	0.0%	0.0%	0.0%	0.0%	0.0%	0.0%	0.0%	0.0%	0.0%	0.0%	0.0%	0.1%
Buses	1	11	1	0	13	1	15	0	0	16	4	11	2	0	17	0	15	1	0	16	0	0	0	0	62
% Buses	1.7%	1.7%	1.9%	0.0%	0.0%	0.0%	6.0%	0.0%	0.0%	0.0%	4.4%	1.7%	2.6%	0.0%	0.0%	0.0%	5.9%	2.4%	0.0%	0.0%	0.0%	0.0%	0.0%	0.0%	2.6%
Pedestrians	0	0	0	0	0	0	0	0	0	0	0	0	0	0	0	0	0	0	0	0	41	32	0	0	0
% Pedestrians	0.0%	0.0%	0.0%	0.0%	0.0%	0.0%	0.0%	0.0%	0.0%	0.0%	0.0%	0.0%	0.0%	0.0%	0.0%	0.0%	0.0%	0.0%	0.0%	0.0%	85.3%	87.0%	0.0%	0.0%	0.0%
Bicycles on Crosswalk	0	0	0	0	0	0	0	0	0	0	0	0	0	0	0	0	0	0	0	0	2	1	0	0	0
% Bicycles on Crosswalk	0.0%	0.0%	0.0%	0.0%	0.0%	0.0%	0.0%	0.0%	0.0%	0.0%	0.0%	0.0%	0.0%	0.0%	0.0%	0.0%	0.0%	0.0%	0.0%	0.0%	4.7%	3.0%	0.0%	0.0%	0.0%

Project : VBH Malta NY  
 Site : Site 4  
 Location : 42.948550, -73.790036  
 Survey Date : 2021-04-28, Wednesday

### Turning Movement Data Plot

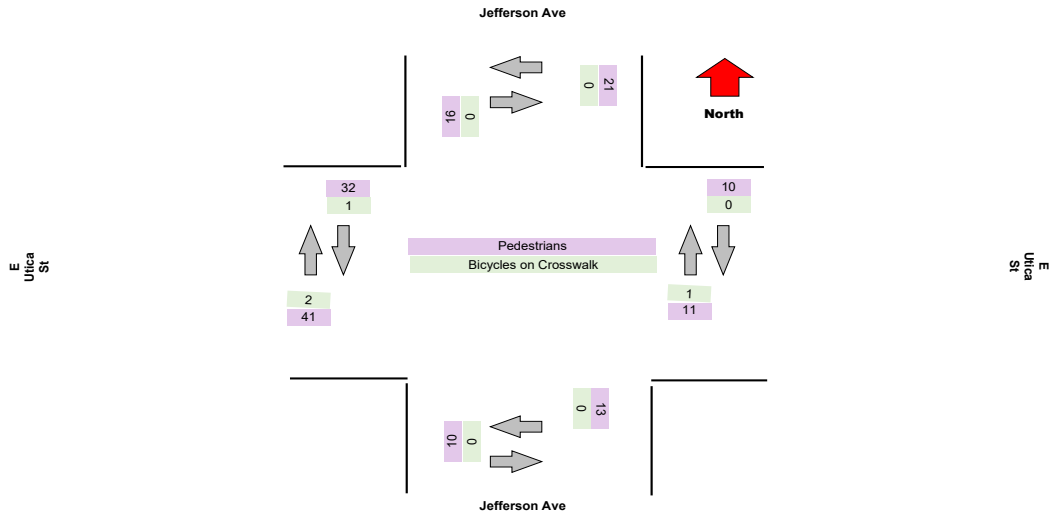
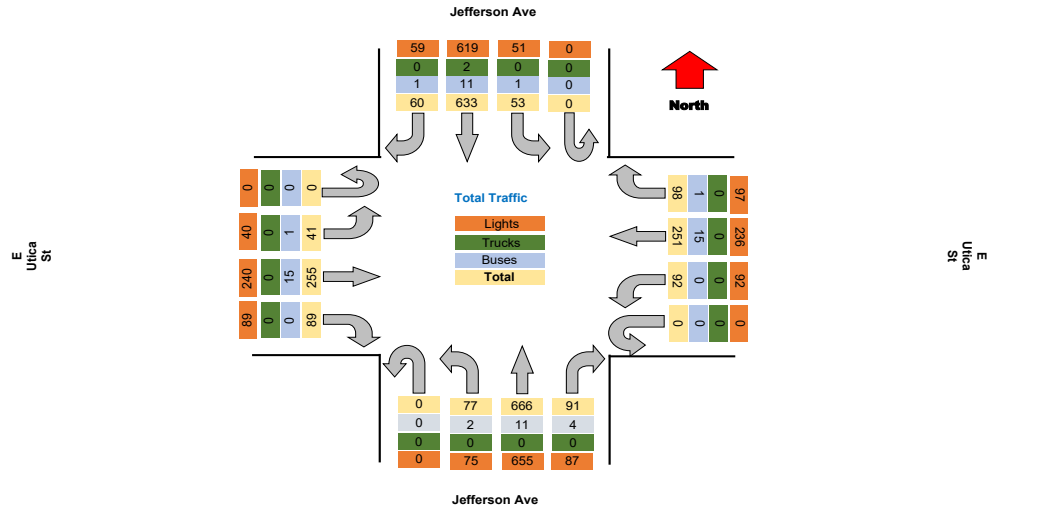

Project : VBH Malta NY  
Site : Site 4  
Location : 42.948550, -73.790036  
Survey Date : 2021-04-28, Wednesday

TSTData.com

**Turning Movement Peak Hour Data (AM)**

7:30:00 AM

Leg Direction	Jefferson Ave				E Ulica St				Jefferson Ave				E Ulica St				Total			
	Right	Thru	Left	U-Turn	Right	Thru	Left	U-Turn	Right	Thru	Left	U-Turn	Right	Thru	Left	U-Turn				
7:30:00 AM	1	24	2	0	7	5	4	0	1	24	4	0	1	10	2	0	13	4	2	87
7:45:00 AM	3	22	4	0	1	18	1	0	4	20	3	0	4	6	1	0	11	3	2	87
8:00:00 AM	2	25	1	0	5	20	2	0	5	21	8	0	7	15	1	0	23	7	5	113
8:15:00 AM	5	32	2	0	2	15	4	0	4	20	2	0	3	9	0	0	12	2	1	99
<b>Grand Total</b>	<b>11</b>	<b>103</b>	<b>9</b>	<b>0</b>	<b>15</b>	<b>58</b>	<b>11</b>	<b>0</b>	<b>14</b>	<b>85</b>	<b>17</b>	<b>0</b>	<b>15</b>	<b>40</b>	<b>4</b>	<b>0</b>	<b>59</b>	<b>15</b>	<b>10</b>	<b>388</b>
% Approach	8.9%	83.7%	7.3%	0.0%	17.6%	68.2%	12.9%	0.0%	11.8%	71.4%	14.3%	0.0%	25.4%	67.8%	6.8%	0.0%	0.0%	0.0%	0.0%	0.0%
% Total	2.8%	26.7%	2.3%	0.0%	3.9%	15.0%	2.8%	0.0%	3.6%	22.0%	4.4%	0.0%	3.9%	10.4%	1.0%	0.0%	15.3%	0.0%	0.0%	0.0%
PHF	0.550	0.805	0.563	0.000	0.536	0.725	0.688	0.000	0.700	0.885	0.531	0.000	0.536	0.667	0.500	0.000	0.641	0.000	0.000	0.854
Lights	11	101	9	0	15	54	11	0	13	81	17	0	15	36	4	0	55	0	0	367
% Lights	100.0%	98.1%	100.0%	0.0%	100.0%	93.1%	100.0%	0.0%	92.9%	95.3%	100.0%	0.0%	100.0%	90.0%	100.0%	0.0%	93.2%	0.0%	0.0%	95.1%
Trucks	0	1	0	0	0	0	0	0	0	0	0	0	0	0	0	0	0	0	0	1
% Trucks	0.0%	1.0%	0.0%	0.0%	0.0%	0.0%	0.0%	0.0%	0.0%	0.0%	0.0%	0.0%	0.0%	0.0%	0.0%	0.0%	0.0%	0.0%	0.0%	0.3%
Buses	0	1	0	0	0	4	0	0	1	4	0	0	0	4	0	0	4	0	0	14
% Buses	0.0%	1.0%	0.0%	0.0%	0.0%	6.9%	0.0%	0.0%	7.1%	4.7%	0.0%	0.0%	0.0%	10.0%	0.0%	0.0%	6.8%	0.0%	0.0%	3.6%
Pedestrians	0	0	0	0	0	0	0	0	0	0	0	0	0	0	0	0	0	0	0	0
% Pedestrians	0.0%	0.0%	0.0%	0.0%	0.0%	0.0%	0.0%	0.0%	0.0%	0.0%	0.0%	0.0%	0.0%	0.0%	0.0%	0.0%	0.0%	0.0%	0.0%	0.0%
Bicycles on Crosswalk	0	0	0	0	0	0	0	0	0	0	0	0	0	0	0	0	0	0	0	0
% Bicycles on Crosswalk	0.0%	0.0%	0.0%	0.0%	0.0%	0.0%	0.0%	0.0%	0.0%	0.0%	0.0%	0.0%	0.0%	0.0%	0.0%	0.0%	0.0%	0.0%	0.0%	0.0%

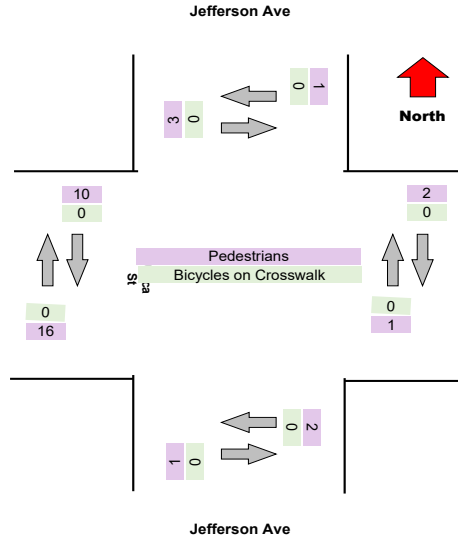
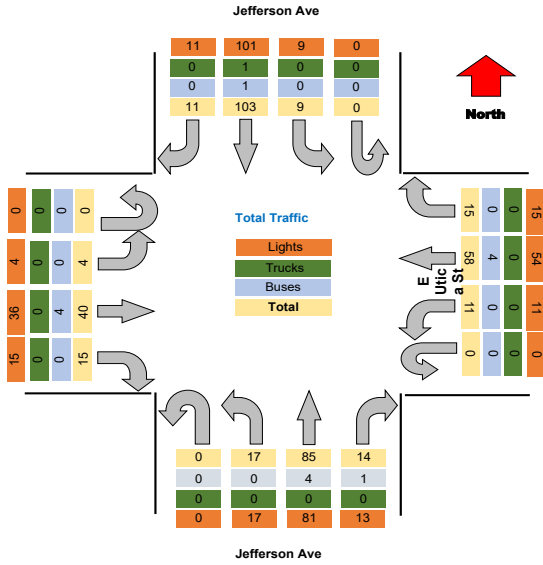

Project : VBH Malta NY  
Site : Site 4  
Location : 42.948550, -73.790036

TSTData.com

Survey Date : 2021-04-28, Wednesday

**Turning Movement Peak Hour Data (PM)**

4:15:00 PM

Leg Direction	Jefferson Ave										E Ulica St										Jefferson Ave										E Ulica St										Total
	Southbound					Westbound					Northbound					Eastbound																									
	Right	Thru	Left	U-Turn	App Total	Peds CW	Peds CCW	Right	Thru	Left	U-Turn	App Total	Peds CW	Peds CCW	Right	Thru	Left	U-Turn	App Total	Peds CW	Peds CCW	Right	Thru	Left	U-Turn	App Total	Peds CW	Peds CCW													
4:15:00 PM	7	55	4	0	66	1	1	11	19	7	0	37	0	1	5	58	4	0	67	0	0	11	20	3	0	34	1	1	204												
4:30:00 PM	4	75	5	0	84	3	0	12	22	13	0	47	0	1	9	58	8	0	75	2	1	5	26	7	0	38	2	4	244												
4:45:00 PM	7	53	5	0	65	0	0	8	22	7	0	37	0	1	9	67	8	0	84	0	0	9	27	3	0	39	4	9	225												
5:00:00 PM	2	53	4	0	59	0	0	9	25	9	0	44	1	0	17	54	7	0	88	4	1	9	21	4	0	34	4	2	235												
<b>Grand Total</b>	20	245	18	0	284	4	1	40	89	36	0	165	1	2	40	247	27	0	314	4	2	34	64	17	0	145	11	16	998												
% Approach	7.0%	86.6%	6.3%	0.0%	0.0%	0.0%	0.0%	24.2%	53.9%	21.8%	0.0%	0.0%	0.0%	0.0%	12.7%	78.7%	8.6%	0.0%	0.0%	0.0%	0.0%	23.4%	64.8%	11.7%	0.0%	0.0%	0.0%	0.0%	0.0%												
% Total	2.2%	27.1%	2.0%	0.0%	31.3%	0.0%	0.0%	4.4%	9.8%	4.0%	0.0%	18.2%	0.0%	0.0%	4.4%	27.2%	3.0%	0.0%	34.6%	0.0%	0.0%	3.7%	10.4%	1.9%	0.0%	16.0%	0.0%	0.0%	0.0%												
PHF	0.714	0.820	0.900	0.000	0.845	0.000	0.000	0.833	0.856	0.692	0.000	0.878	0.000	0.000	0.588	0.922	0.844	0.000	0.892	0.000	0.000	0.773	0.870	0.607	0.000	0.929	0.000	0.000	0.930												
Lights	20	241	17	0	278	0	0	39	86	36	0	161	0	0	39	244	26	0	309	0	0	34	91	17	0	142	0	0	890												
% Lights	100.0%	98.0%	94.4%	0.0%	97.9%	0.0%	0.0%	97.5%	96.6%	100.0%	0.0%	97.6%	0.0%	0.0%	97.5%	98.8%	96.3%	0.0%	98.4%	0.0%	0.0%	100.0%	96.8%	100.0%	0.0%	97.9%	0.0%	0.0%	98.0%												
Trucks	0	1	0	0	1	0	0	0	0	0	0	0	0	0	0	0	0	0	0	0	0	0	0	0	0	0	0	0	1												
% Trucks	0.0%	0.4%	0.0%	0.0%	0.4%	0.0%	0.0%	0.0%	0.0%	0.0%	0.0%	0.0%	0.0%	0.0%	0.0%	0.0%	0.0%	0.0%	0.0%	0.0%	0.0%	0.0%	0.0%	0.0%	0.0%	0.0%	0.0%	0.0%	0.1%												
Buses	0	3	0	0	3	0	0	1	3	0	0	4	0	0	1	3	1	0	5	0	0	0	3	0	0	3	0	0	15												
% Buses	0.0%	1.2%	0.0%	0.0%	0.0%	0.0%	0.0%	2.5%	3.4%	0.0%	0.0%	0.0%	0.0%	0.0%	2.5%	1.2%	3.7%	0.0%	0.0%	0.0%	0.0%	0.0%	3.2%	0.0%	0.0%	0.0%	0.0%	0.0%	1.7%												
Pedestrians	0	0	0	0	0	7	4	0	0	0	0	1	3	0	0	0	0	0	6	6	2	0	0	0	0	0	10	16	0												
% Pedestrians	0.0%	0.0%	0.0%	0.0%	0.0%	100.0%	100.0%	0.0%	0.0%	0.0%	0.0%	0.0%	0.0%	0.0%	0.0%	0.0%	0.0%	0.0%	0.0%	100.0%	100.0%	0.0%	0.0%	0.0%	0.0%	0.0%	0.0%	100.0%	0.0%	0.0%											
Bicycles on Crosswalk	0	0	0	0	0	0	0	0	0	0	0	0	0	0	0	0	0	0	0	0	0	0	0	0	0	0	1	0	0												
% Bicycles on Crosswalk	0.0%	0.0%	0.0%	0.0%	0.0%	0.0%	0.0%	0.0%	0.0%	0.0%	0.0%	0.0%	0.0%	0.0%	0.0%	0.0%	0.0%	0.0%	0.0%	0.0%	0.0%	0.0%	0.0%	0.0%	0.0%	0.0%	8.1%	0.0%	0.0%												

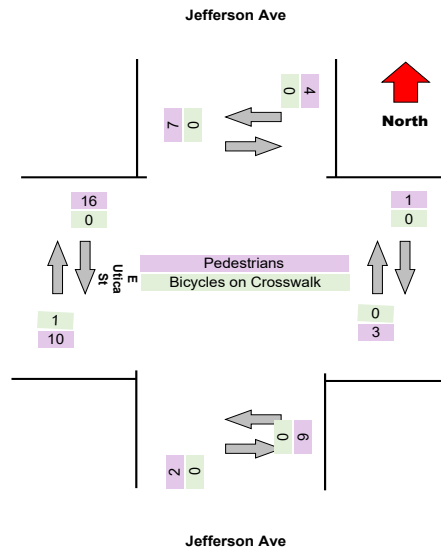
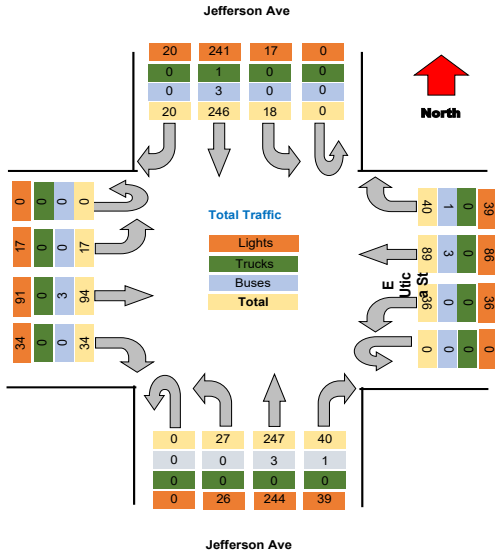



Project : VBH Malta NY  
 Site : Site 4  
 Location : 42.948550, -73.790036  
 Survey Date : 2021-04-28, Wednesday

### Turning Movement Data Plot

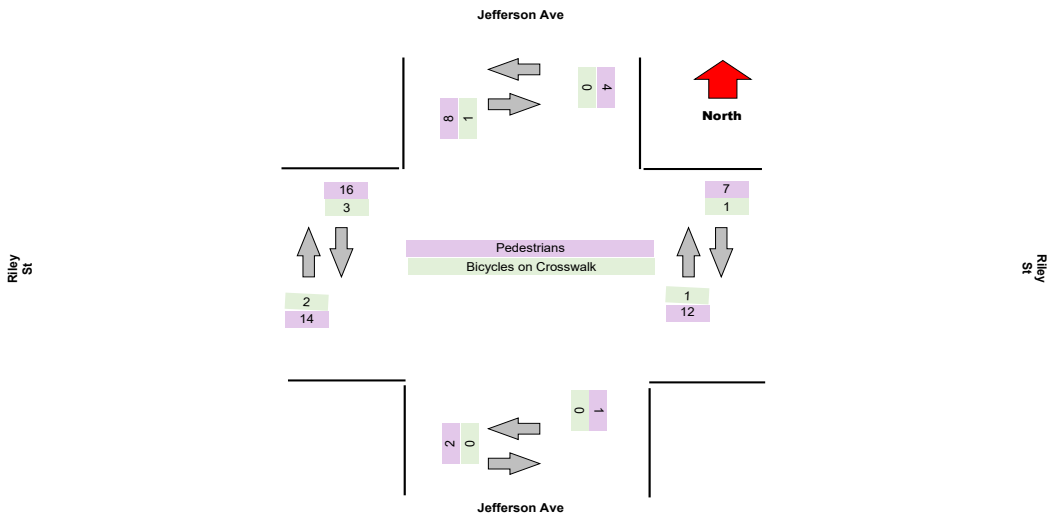
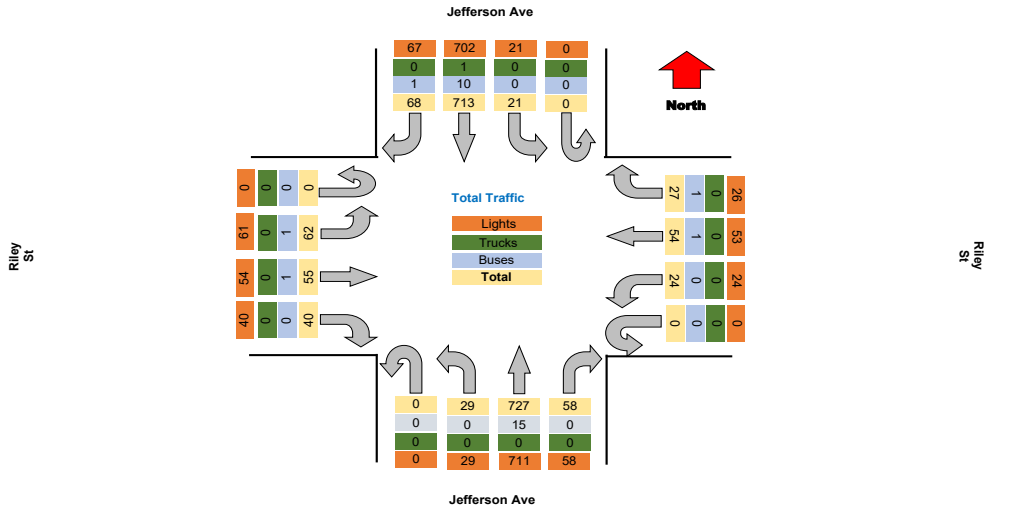



Project : VBH Malta NY  
 Site : Site 4  
 Location : 42.948550, -73.790036  
 Survey Date : 2021-04-28, Wednesday

TSTData.com

**Turning Movement Peak Hour Data (AM)**

7:30:00 AM

Leg Direction	Jefferson Ave					Riley St					Jefferson Ave					Riley St					Total	
	Southbound					Westbound					Northbound					Eastbound						
Start Time	Right	Thru	Left	U-Turn	App Total	Peds CW	Peds CCW	Right	Thru	Left	U-Turn	App Total	Peds CW	Peds CCW	Right	Thru	Left	U-Turn	App Total	Peds CW	Peds CCW	Total
7:30:00 AM	1	23	0	0	24	1	1	0	3	0	0	4	0	1	1	24	0	0	26	0	0	60
7:45:00 AM	1	28	0	0	29	0	1	0	6	0	0	7	0	0	2	26	0	0	28	0	0	67
8:00:00 AM	2	29	0	0	31	0	0	0	3	3	0	7	0	0	5	26	4	0	35	0	0	85
8:15:00 AM	0	40	0	0	40	0	0	1	6	0	0	7	0	0	2	26	1	0	29	0	0	95
Grand Total	4	120	0	0	124	1	2	1	18	3	0	24	0	1	10	102	5	0	118	0	0	307
% Approach	3.2%	96.8%	0.0%	0.0%	0.0%	0.0%	0.0%	4.2%	75.0%	12.5%	0.0%	0.0%	0.0%	0.0%	8.5%	96.4%	4.2%	0.0%	0.0%	0.0%	0.0%	0.0%
% Total	1.3%	39.1%	0.0%	0.0%	40.4%	0.0%	0.0%	0.3%	5.9%	1.0%	0.0%	7.8%	0.0%	0.0%	3.3%	33.2%	1.6%	0.0%	38.4%	0.0%	0.0%	0.0%
PHF	0.500	0.750	0.000	0.000	0.775	0.000	0.000	0.250	0.750	0.250	0.000	0.857	0.000	0.000	0.500	0.981	0.313	0.000	0.843	0.000	0.000	0.808
Lights	4	119	0	0	123	0	0	1	18	3	0	22	0	0	10	97	5	0	112	0	0	298
% Lights	100.0%	99.2%	0.0%	0.0%	99.2%	0.0%	0.0%	100.0%	100.0%	100.0%	0.0%	91.7%	0.0%	0.0%	100.0%	95.1%	100.0%	0.0%	94.9%	0.0%	0.0%	97.1%
Trucks	0	0	0	0	0	0	0	0	0	0	0	0	0	0	0	0	0	0	0	0	0	0
% Trucks	0.0%	0.0%	0.0%	0.0%	0.0%	0.0%	0.0%	0.0%	0.0%	0.0%	0.0%	0.0%	0.0%	0.0%	0.0%	0.0%	0.0%	0.0%	0.0%	0.0%	0.0%	0.0%
Buses	0	1	0	0	1	0	0	0	0	0	0	0	0	0	0	5	0	0	5	0	0	6
% Buses	0.0%	0.8%	0.0%	0.0%	0.0%	0.0%	0.0%	0.0%	0.0%	0.0%	0.0%	0.0%	0.0%	0.0%	0.0%	4.9%	0.0%	0.0%	0.0%	0.0%	0.0%	2.0%
Pedestrians	0	0	0	0	0	1	2	0	0	0	0	0	1	0	0	0	0	0	0	0	5	3
% Pedestrians	0.0%	0.0%	0.0%	0.0%	0.0%	100.0%	100.0%	0.0%	0.0%	0.0%	0.0%	0.0%	0.0%	100.0%	0.0%	0.0%	0.0%	0.0%	0.0%	0.0%	100.0%	75.0%
Bicycles on Crosswalk	0	0	0	0	0	0	0	0	0	0	0	0	0	0	0	0	0	0	0	0	0	1
% Bicycles on Crosswalk	0.0%	0.0%	0.0%	0.0%	0.0%	0.0%	0.0%	0.0%	0.0%	0.0%	0.0%	0.0%	0.0%	0.0%	0.0%	0.0%	0.0%	0.0%	0.0%	0.0%	0.0%	25.0%

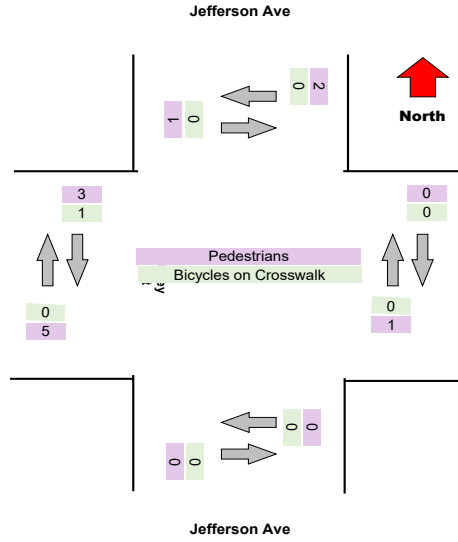
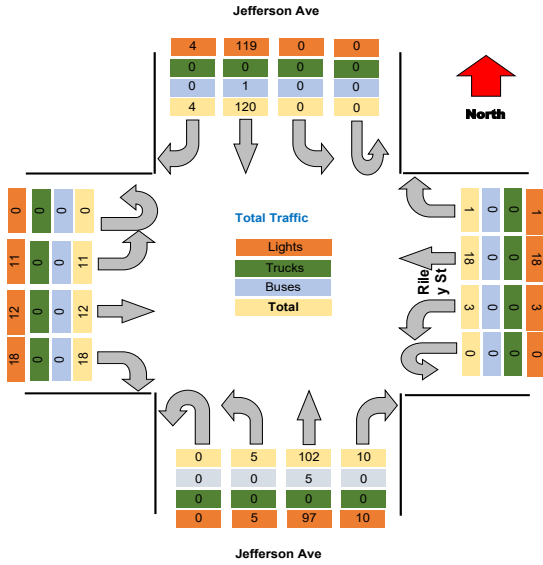

**Turning Movement Peak Hour Data (PM)**

4:15:00 PM

Leg Direction	Jefferson Ave										Riley St										Jefferson Ave										Riley St										Total
	Southbound					Westbound					Northbound					Eastbound																									
	Right	Thru	Left	U-Turn	App Total	Right	Thru	Left	U-Turn	App Total	Right	Thru	Left	U-Turn	App Total	Right	Thru	Left	U-Turn	App Total																					
4:15:00 PM	8	55	3	0	66	2	4	5	0	11	4	60	3	0	67	2	3	5	0	10																					
4:30:00 PM	10	86	4	0	100	4	2	1	0	7	11	71	2	0	84	2	7	5	0	14																					
4:45:00 PM	6	58	3	0	67	4	4	3	0	11	3	69	3	0	75	1	3	7	0	11																					
5:00:00 PM	11	52	2	0	65	4	4	1	0	9	4	54	2	0	60	0	5	9	0	14																					
<b>Grand Total</b>	<b>35</b>	<b>257</b>	<b>12</b>	<b>0</b>	<b>288</b>	<b>14</b>	<b>14</b>	<b>10</b>	<b>0</b>	<b>38</b>	<b>22</b>	<b>294</b>	<b>10</b>	<b>0</b>	<b>316</b>	<b>5</b>	<b>18</b>	<b>25</b>	<b>0</b>	<b>48</b>																					
% Approach	11.4%	84.7%	3.9%	0.0%	0.0%	36.8%	36.8%	26.3%	0.0%	0.0%	7.0%	89.9%	3.2%	0.0%	0.0%	10.2%	36.7%	53.1%	0.0%	0.0%																					
% Total	4.9%	36.7%	1.7%	0.0%	43.3%	2.0%	2.0%	1.4%	0.0%	5.3%	3.1%	39.9%	1.4%	0.0%	44.4%	0.7%	2.5%	3.7%	0.0%	6.9%																					
PHF	0.795	0.759	0.750	0.000	0.770	0.875	0.875	0.500	0.000	0.864	0.500	0.845	0.833	0.000	0.878	0.625	0.643	0.722	0.000	0.875																					
Lights	35	257	12	0	304	13	14	10	0	37	22	279	10	0	311	5	18	25	0	48																					
% Lights	100.0%	98.5%	100.0%	0.0%	98.7%	82.9%	100.0%	100.0%	0.0%	97.4%	100.0%	98.2%	100.0%	0.0%	98.4%	100.0%	100.0%	98.2%	0.0%	98.0%																					
Trucks	0	1	0	0	1	0	0	0	0	0	0	0	0	0	0	0	0	0	0	0																					
% Trucks	0.0%	0.4%	0.0%	0.0%	0.3%	0.0%	0.0%	0.0%	0.0%	0.0%	0.0%	0.0%	0.0%	0.0%	0.0%	0.0%	0.0%	0.0%	0.0%	0.0%																					
Buses	0	3	0	0	3	1	0	0	0	1	0	4	0	0	4	0	0	1	0	1																					
% Buses	0.0%	1.1%	0.0%	0.0%	0.0%	7.1%	0.0%	0.0%	0.0%	0.0%	0.0%	1.4%	0.0%	0.0%	0.0%	0.0%	0.0%	3.8%	0.0%	0.0%																					
Pedestrians	0	0	0	0	0	0	0	0	0	0	0	0	0	0	0	0	0	0	0	0																					
% Pedestrians	0.0%	0.0%	0.0%	0.0%	0.0%	0.0%	0.0%	0.0%	0.0%	0.0%	0.0%	0.0%	0.0%	0.0%	0.0%	0.0%	0.0%	0.0%	0.0%	0.0%																					
Bicycles on Crosswalk	0	0	0	0	0	0	0	0	0	1	0	0	0	0	0	0	0	0	0	0																					
% Bicycles on Crosswalk	0.0%	0.0%	0.0%	0.0%	0.0%	0.0%	0.0%	0.0%	0.0%	0.0%	0.0%	0.0%	0.0%	0.0%	0.0%	0.0%	0.0%	0.0%	0.0%	0.0%																					

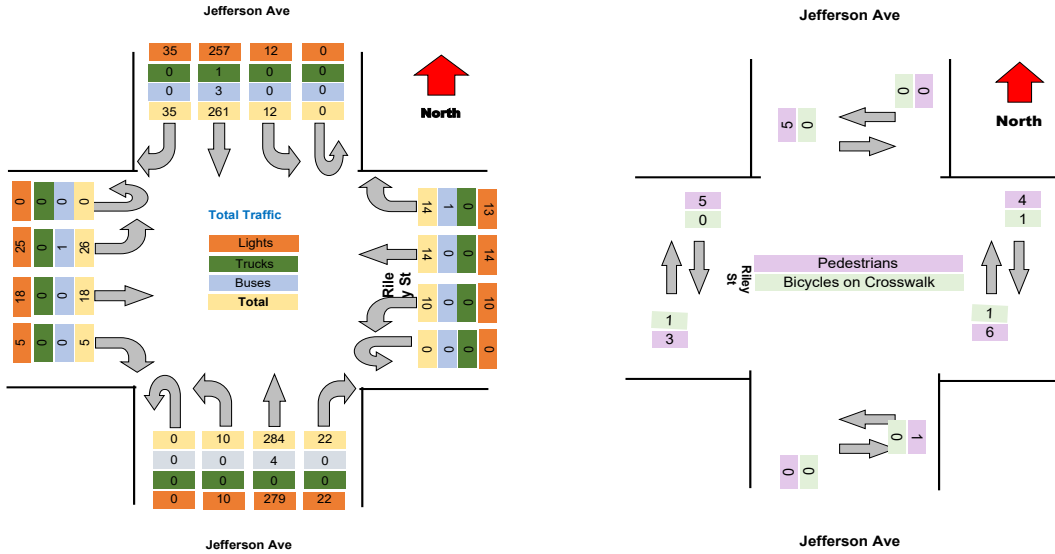

Project : VBH Malta NY  
Site : Site 4  
Location : 42.948550, -73.790036

TSTData.com

Survey Date : 2021-04-28, Wednesday

Project	LaBella
Project Code	LaBella
Site Name	34
Legs and Movements	All Processed Legs & Move
Bin Size	15 minutes
Survey Date	2021-11-03, Wednesday
Location	34
Latitude and Longitude	42.909386, -78.853967

	Start	End	PHF
Forced Peak AM	2021/11/03 07:30:00	2021/11/03 08:30:00	0.89
Forced Peak PM	2021/11/03 16:30:00	2021/11/03 17:30:00	0.91
AM Peak	2021/11/03 07:30:00	2021/11/03 08:30:00	0.89
PM Peak	2021/11/03 16:15:00	2021/11/03 17:15:00	0.92

### Turning Movement Data

Leg Direction	Jefferson Ave												Riley St												Jefferson Ave												Riley St												Total
	Southbound						Westbound						Northbound						Eastbound																														
	Right	Thru	Left	U-Turn	App Total	Peds CW	Peds CCW	Right	Thru	Left	U-Turn	App Total	Peds CW	Peds CCW	Right	Thru	Left	U-Turn	App Total	Peds CW	Peds CCW	Right	Thru	Left	U-Turn	App Total	Peds CW	Peds CCW																					
6:30:00 AM	1	12	0	0	13	0	0	0	2	0	0	2	0	0	2	19	0	0	21	0	0	1	2	3	0	6	1	0	42																				
6:45:00 AM	2	18	0	0	20	0	0	2	0	3	0	5	0	2	3	22	1	0	28	0	0	2	2	3	0	4	2	0	57																				
Hourly Total	3	30	0	0	33	0	0	2	2	3	0	7	0	2	5	41	1	0	49	0	0	3	4	3	0	10	3	0	99																				
7:00:00 AM	1	28	0	0	29	0	0	2	3	2	0	7	0	0	2	41	1	0	44	0	0	2	2	3	0	7	1	2	85																				
7:15:00 AM	2	30	2	0	34	0	1	3	4	1	0	9	0	0	7	31	0	0	38	0	0	2	1	0	0	3	0	0	84																				
7:30:00 AM	2	31	0	0	33	0	0	0	6	2	0	8	0	0	3	29	3	0	35	0	0	8	4	0	0	12	2	1	88																				
7:45:00 AM	2	84	0	0	86	4	1	3	2	1	0	7	0	0	0	38	1	0	39	0	0	0	5	0	0	5	5	0	117																				
Hourly Total	7	151	2	0	160	4	2	8	15	6	0	31	0	0	12	139	5	0	156	0	0	12	12	3	0	27	8	3	374																				
8:00:00 AM	3	54	1	0	58	0	0	0	1	3	0	4	0	0	1	44	3	0	48	0	0	3	6	3	0	12	0	1	122																				
8:15:00 AM	1	37	0	0	38	1	0	2	5	1	0	8	0	1	2	43	1	0	47	0	0	2	7	4	0	13	3	1	106																				
Hourly Total	4	91	1	0	96	1	0	2	6	4	0	12	0	1	3	87	4	0	95	0	0	5	13	7	0	25	3	2	228																				
4:00:00 PM	5	61	1	0	67	0	0	2	3	4	0	9	1	0	9	82	2	0	93	1	0	3	9	4	0	16	2	3	185																				
4:15:00 PM	1	88	2	0	91	1	6	4	4	4	0	12	0	1	9	79	1	0	89	0	0	1	8	2	0	11	0	0	183																				
4:30:00 PM	9	81	5	0	95	0	1	4	3	4	0	11	2	2	12	60	0	0	72	0	0	5	7	4	0	18	0	0	194																				
4:45:00 PM	3	54	2	0	59	0	0	3	6	5	0	14	0	2	7	72	1	0	80	0	1	1	5	2	0	8	1	0	161																				
Hourly Total	18	264	10	0	292	1	7	13	18	17	0	48	3	5	37	293	4	0	334	1	1	10	29	12	0	51	3	3	723																				
5:00:00 PM	4	79	1	0	84	0	0	5	6	2	0	13	0	1	9	80	4	0	93	0	1	3	6	3	0	12	2	2	202																				
5:15:00 PM	11	60	2	0	73	0	2	1	4	3	0	8	1	0	4	75	1	0	80	3	0	3	10	3	0	16	0	3	177																				
5:30:00 PM	6	66	3	0	75	0	0	2	2	2	0	6	0	2	5	61	2	0	68	1	0	2	7	3	0	12	1	1	161																				
5:45:00 PM	4	59	2	0	65	0	2	0	2	1	0	3	1	0	2	51	1	0	54	0	0	2	1	3	0	6	3	2	128																				
Hourly Total	25	284	8	0	297	0	4	8	14	8	0	30	2	3	20	287	8	0	295	4	1	10	24	12	0	46	6	8	688																				
Grand Total	57	800	21	0	878	5	13	33	53	38	0	126	5	11	77	827	22	0	929	5	2	40	82	37	0	159	23	16	2092																				
% Approach	6.5%	91.1%	2.4%	0.0%	0.0%	0.0%	0.0%	26.2%	42.1%	30.2%	0.0%	0.0%	0.0%	0.0%	6.3%	89.0%	2.4%	0.0%	0.0%	0.0%	0.0%	25.2%	51.6%	23.3%	0.0%	0.0%	0.0%	0.0%	0.0%																				
% Total	2.7%	38.2%	1.0%	0.0%	42.0%	0.0%	0.0%	1.6%	2.5%	1.8%	0.0%	6.0%	0.0%	0.0%	3.7%	39.5%	1.1%	0.0%	44.4%	0.0%	0.0%	1.9%	3.9%	1.8%	0.0%	7.6%	0.0%	0.0%	0.0%																				
Lights	56	758	19	0	833	0	0	29	51	36	0	116	0	0	75	796	19	0	890	0	0	36	76	35	0	147	0	0	1886																				
% Lights	98.2%	94.8%	90.5%	0.0%	94.3%	0.0%	0.0%	87.9%	86.2%	94.7%	0.0%	92.1%	0.0%	0.0%	87.4%	86.3%	86.4%	0.0%	95.8%	0.0%	0.0%	90.0%	92.7%	94.6%	0.0%	92.5%	0.0%	0.0%	94.9%																				
Trucks	0	2	0	0	2	0	0	0	0	0	0	0	0	0	0	0	0	0	0	0	0	0	0	0	0	0	0	0	2																				
% Trucks	0.0%	0.3%	0.0%	0.0%	0.2%	0.0%	0.0%	0.0%	0.0%	0.0%	0.0%	0.0%	0.0%	0.0%	0.0%	0.0%	0.0%	0.0%	0.0%	0.0%	0.0%	0.0%	0.0%	0.0%	0.0%	0.0%	0.0%	0.0%	0.1%																				
Buses	1	40	2	0	43	0	0	4	2	2	0	8	0	0	2	31	3	0	36	0	0	4	6	2	0	12	0	0	99																				
% Buses	1.8%	5.0%	9.5%	0.0%	0.0%	0.0%	0.0%	0.0%	3.8%	5.3%	0.0%	0.0%	0.0%	0.0%	2.6%	3.7%	13.6%	0.0%	0.0%	0.0%	10.0%	7.3%	5.4%	0.0%	0.0%	0.0%	0.0%	4.7%																					
Pedestrians	0	0	0	0	0	6	13	0	0	0	0	0	5	11	0	0	0	0	0	5	2	0	0	0	0	0	23	15	0																				
% Pedestrians	0.0%	0.0%	0.0%	0.0%	0.0%	100.0%	100.0%	0.0%	0.0%	0.0%	0.0%	0.0%	100.0%	100.0%	0.0%	0.0%	0.0%	0.0%	0.0%	100.0%	100.0%	0.0%	0.0%	0.0%	0.0%	0.0%	100.0%	93.8%	0.0%																				
Bicycles on Crosswalk	0	0	0	0	0	0	0	0	0	0	0	0	0	0	0	0	0	0	0	0	0	0	0	0	0	0	0	1	0																				
% Bicycles on Crosswalk	0.0%	0.0%	0.0%	0.0%	0.0%	0.0%	0.0%	0.0%	0.0%	0.0%	0.0%	0.0%	0.0%	0.0%	0.0%	0.0%	0.0%	0.0%	0.0%	0.0%	0.0%	0.0%	0.0%	0.0%	0.0%	0.0%	0.0%	0.3%	0.0%																				

**Turning Movement Data Plot**

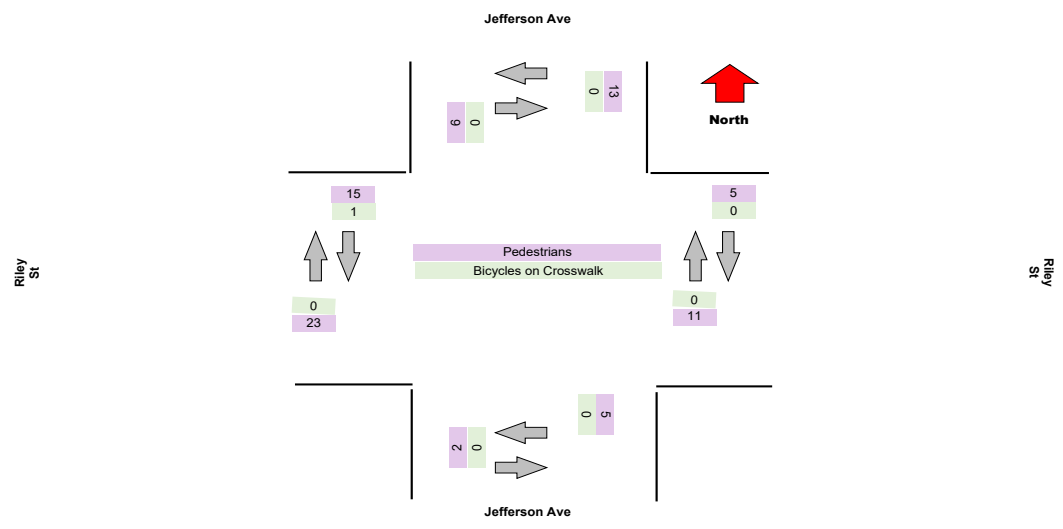
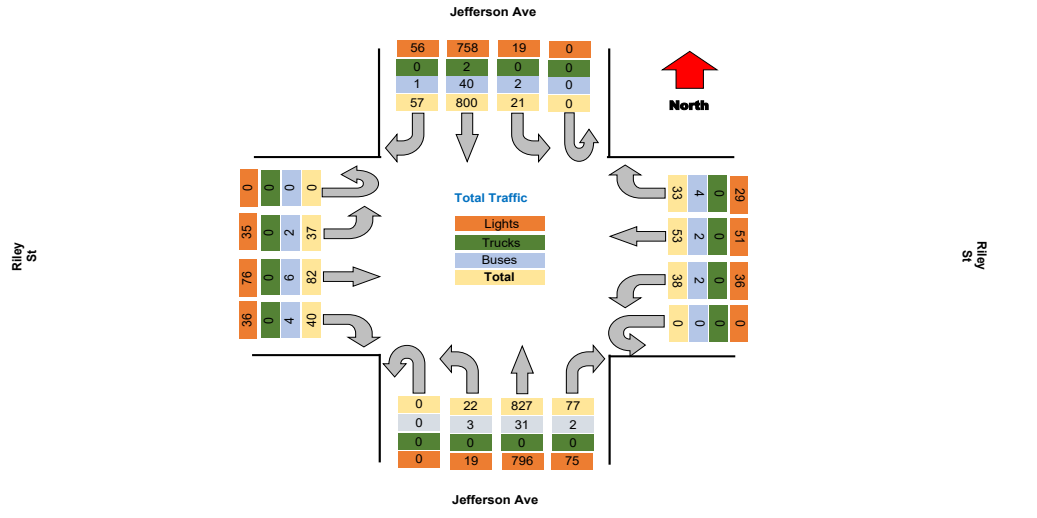

Project : VBH Malta NY  
 Site : Site 4  
 Location : 42.948550, -73.790036  
 Survey Date : 2021-04-28, Wednesday

TSTData.com

**Turning Movement Peak Hour Data (AM)**

7:30:00 AM

Leg Direction	Jefferson Ave					Riley St					Jefferson Ave					Riley St					Total									
	Southbound					Westbound					Northbound					Eastbound														
Start Time	Right	Thru	Left	U-Turn	App Total	Peds CW	Peds CCW	Right	Thru	Left	U-Turn	App Total	Peds CW	Peds CCW	Right	Thru	Left	U-Turn	App Total	Peds CW	Peds CCW	Right	Thru	Left	U-Turn	App Total	Peds CW	Peds CCW		
7:30:00 AM	2	31	0	0	33	0	0	0	6	2	0	8	0	0	3	29	3	0	35	0	0	8	4	0	0	12	2	1	88	
7:45:00 AM	2	64	0	0	66	4	1	3	2	1	0	7	0	0	0	38	1	0	39	0	0	0	5	0	0	5	5	0	117	
8:00:00 AM	3	54	1	0	58	0	0	0	1	3	0	4	0	0	1	44	3	0	48	0	0	3	6	3	0	12	0	1	122	
8:15:00 AM	1	37	0	0	38	1	0	2	5	1	0	8	0	1	2	43	1	0	47	0	0	2	7	4	0	13	3	1	106	
<b>Grand Total</b>	<b>9</b>	<b>186</b>	<b>1</b>	<b>0</b>	<b>195</b>	<b>5</b>	<b>1</b>	<b>5</b>	<b>14</b>	<b>7</b>	<b>0</b>	<b>27</b>	<b>0</b>	<b>1</b>	<b>6</b>	<b>154</b>	<b>8</b>	<b>0</b>	<b>169</b>	<b>0</b>	<b>0</b>	<b>13</b>	<b>22</b>	<b>7</b>	<b>0</b>	<b>42</b>	<b>10</b>	<b>3</b>	<b>433</b>	
<b>% Approach</b>	4.1%	95.4%	0.5%	0.0%	0.0%	0.0%	0.0%	18.5%	51.9%	25.9%	0.0%	0.0%	0.0%	0.0%	3.6%	91.1%	4.7%	0.0%	0.0%	0.0%	0.0%	31.0%	52.4%	16.7%	0.0%	0.0%	0.0%	0.0%	0.0%	
<b>% Total</b>	1.8%	43.0%	0.2%	0.0%	45.0%	0.0%	0.0%	1.2%	3.2%	1.6%	0.0%	6.2%	0.0%	0.0%	1.4%	35.6%	1.8%	0.0%	39.0%	0.0%	0.0%	3.0%	5.1%	1.6%	0.0%	9.7%	0.0%	0.0%	0.0%	
<b>PHF</b>	0.667	0.727	0.250	0.000	0.739	0.000	0.000	0.417	0.583	0.583	0.000	0.844	0.000	0.000	0.500	0.875	0.667	0.000	0.880	0.000	0.000	0.406	0.786	0.438	0.000	0.808	0.000	0.000	0.887	
<b>Lights</b>	8	171	1	0	180	0	0	3	14	5	0	22	0	0	6	138	7	0	151	0	0	11	21	7	0	39	0	0	392	
<b>% Lights</b>	100.0%	91.9%	100.0%	0.0%	92.3%	0.0%	0.0%	80.0%	100.0%	71.4%	0.0%	81.5%	0.0%	0.0%	100.0%	89.6%	87.5%	0.0%	89.3%	0.0%	0.0%	84.6%	95.5%	100.0%	0.0%	92.9%	0.0%	0.0%	90.5%	
<b>Trucks</b>	0	1	0	0	1	0	0	0	0	0	0	0	0	0	0	0	0	0	0	0	0	0	0	0	0	0	0	0	1	
<b>% Trucks</b>	0.0%	0.5%	0.0%	0.0%	0.5%	0.0%	0.0%	0.0%	0.0%	0.0%	0.0%	0.0%	0.0%	0.0%	0.0%	0.0%	0.0%	0.0%	0.0%	0.0%	0.0%	0.0%	0.0%	0.0%	0.0%	0.0%	0.0%	0.0%	0.2%	
<b>Buses</b>	0	14	0	0	14	0	0	2	0	2	0	4	0	0	0	16	1	0	17	0	0	2	1	0	0	3	0	0	38	
<b>% Buses</b>	0.0%	7.5%	0.0%	0.0%	0.0%	0.0%	0.0%	40.0%	0.0%	28.6%	0.0%	0.0%	0.0%	0.0%	0.0%	10.4%	12.5%	0.0%	0.0%	0.0%	0.0%	15.4%	4.5%	0.0%	0.0%	0.0%	0.0%	0.0%	8.8%	
<b>Pedestrians</b>	0	0	0	0	0	5	1	0	0	0	0	0	1	0	0	0	0	0	0	0	0	0	0	0	0	0	10	3	0	
<b>% Pedestrians</b>	0.0%	0.0%	0.0%	0.0%	0.0%	100.0%	100.0%	0.0%	0.0%	0.0%	0.0%	0.0%	0.0%	0.0%	0.0%	0.0%	0.0%	0.0%	0.0%	0.0%	0.0%	0.0%	0.0%	0.0%	0.0%	0.0%	0.0%	100.0%	100.0%	0.0%
<b>Bicycles on Crosswalk</b>	0	0	0	0	0	0	0	0	0	0	0	0	0	0	0	0	0	0	0	0	0	0	0	0	0	0	0	0	0	
<b>% Bicycles on Crosswalk</b>	0.0%	0.0%	0.0%	0.0%	0.0%	0.0%	0.0%	0.0%	0.0%	0.0%	0.0%	0.0%	0.0%	0.0%	0.0%	0.0%	0.0%	0.0%	0.0%	0.0%	0.0%	0.0%	0.0%	0.0%	0.0%	0.0%	0.0%	0.0%	0.0%	

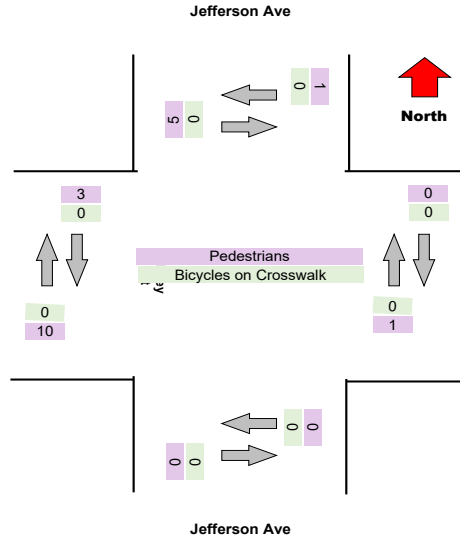
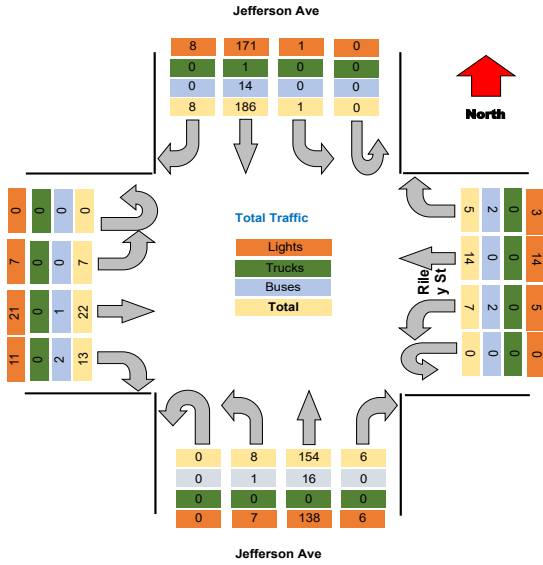

Project : VBH Malta NY  
 Site : Site 4  
 Location : 42.948550, -73.790036  
 Survey Date : 2021-04-28, Wednesday

TSTData.com

### Turning Movement Peak Hour Data (PM)

4:15:00 PM

Leg Direction	Jefferson Ave				Riley St				Jefferson Ave				Riley St				Total												
	Southbound		Westbound		Northbound		Eastbound		Northbound		Eastbound		Eastbound																
Start Time	Right	Thru	Left	U-Turn	App Total	Peds CW	Peds CCW	Right	Thru	Left	U-Turn	App Total	Peds CW	Peds CCW	Right	Thru	Left	U-Turn	App Total	Peds CW	Peds CCW								
4:15:00 PM	1	68	2	0	71	1	6	4	4	4	0	12	0	1	9	79	1	0	89	0	0	183							
4:30:00 PM	9	81	5	0	95	0	1	4	3	4	0	11	2	2	12	60	0	0	72	0	0	194							
4:45:00 PM	3	54	2	0	59	0	0	3	6	5	0	14	0	2	7	72	1	0	80	0	1	161							
5:00:00 PM	4	79	1	0	84	0	0	5	6	2	0	13	0	1	9	80	4	0	93	0	1	202							
<b>Grand Total</b>	<b>17</b>	<b>282</b>	<b>10</b>	<b>0</b>	<b>309</b>	<b>1</b>	<b>7</b>	<b>16</b>	<b>19</b>	<b>15</b>	<b>0</b>	<b>59</b>	<b>2</b>	<b>6</b>	<b>37</b>	<b>291</b>	<b>6</b>	<b>0</b>	<b>334</b>	<b>0</b>	<b>2</b>	<b>740</b>							
% Approach	5.5%	91.3%	3.2%	0.0%	0.0%	0.0%	0.0%	32.0%	38.0%	30.0%	0.0%	0.0%	0.0%	0.0%	11.1%	87.1%	1.8%	0.0%	0.0%	0.0%	0.0%	0.0%	21.3%	55.3%	23.4%	0.0%	0.0%	0.0%	0.0%
% Total	2.3%	38.1%	1.4%	0.0%	41.8%	0.0%	0.0%	2.2%	2.6%	2.0%	0.0%	6.8%	0.0%	0.0%	5.0%	39.3%	0.8%	0.0%	45.1%	0.0%	0.0%	0.0%	1.4%	3.5%	1.5%	0.0%	6.4%	0.0%	0.0%
PHF	0.472	0.870	0.500	0.000	0.813	0.000	0.000	0.800	0.792	0.750	0.000	0.893	0.000	0.000	0.771	0.909	0.375	0.000	0.898	0.000	0.000	0.000	0.500	0.813	0.688	0.000	0.734	0.000	0.000
Lights	16	271	8	0	295	0	0	15	18	15	0	48	0	0	36	286	5	0	327	0	0	0	10	24	9	0	43	0	0
% Lights	84.1%	96.1%	80.0%	0.0%	95.5%	0.0%	0.0%	83.8%	94.7%	100.0%	0.0%	96.0%	0.0%	0.0%	97.3%	98.3%	83.3%	0.0%	97.9%	0.0%	0.0%	0.0%	100.0%	92.3%	81.8%	0.0%	91.5%	0.0%	0.0%
Trucks	0	0	0	0	0	0	0	0	0	0	0	0	0	0	0	0	0	0	0	0	0	0	0	0	0	0	0	0	0
% Trucks	0.0%	0.0%	0.0%	0.0%	0.0%	0.0%	0.0%	0.0%	0.0%	0.0%	0.0%	0.0%	0.0%	0.0%	0.0%	0.0%	0.0%	0.0%	0.0%	0.0%	0.0%	0.0%	0.0%	0.0%	0.0%	0.0%	0.0%	0.0%	0.0%
Buses	1	11	2	0	14	0	0	1	1	0	0	2	0	0	1	5	1	0	7	0	0	0	0	2	2	0	4	0	0
% Buses	5.9%	3.9%	20.0%	0.0%	0.0%	0.0%	0.0%	6.3%	5.3%	0.0%	0.0%	0.0%	0.0%	0.0%	2.7%	1.7%	16.7%	0.0%	0.0%	0.0%	0.0%	0.0%	0.0%	7.7%	18.2%	0.0%	0.0%	0.0%	0.0%
Pedestrians	0	0	0	0	0	1	7	0	0	0	0	2	6	0	0	0	0	0	0	0	2	0	0	0	0	0	0	3	1
% Pedestrians	0.0%	0.0%	0.0%	0.0%	0.0%	100.0%	100.0%	0.0%	0.0%	0.0%	0.0%	0.0%	100.0%	100.0%	0.0%	0.0%	0.0%	0.0%	0.0%	0.0%	0.0%	0.0%	0.0%	0.0%	0.0%	0.0%	0.0%	100.0%	50.0%
Bicycles on Crosswalk	0	0	0	0	0	0	0	0	0	0	0	0	0	0	0	0	0	0	0	0	0	0	0	0	0	0	0	0	1
% Bicycles on Crosswalk	0.0%	0.0%	0.0%	0.0%	0.0%	0.0%	0.0%	0.0%	0.0%	0.0%	0.0%	0.0%	0.0%	0.0%	0.0%	0.0%	0.0%	0.0%	0.0%	0.0%	0.0%	0.0%	0.0%	0.0%	0.0%	0.0%	0.0%	50.0%	0.0%

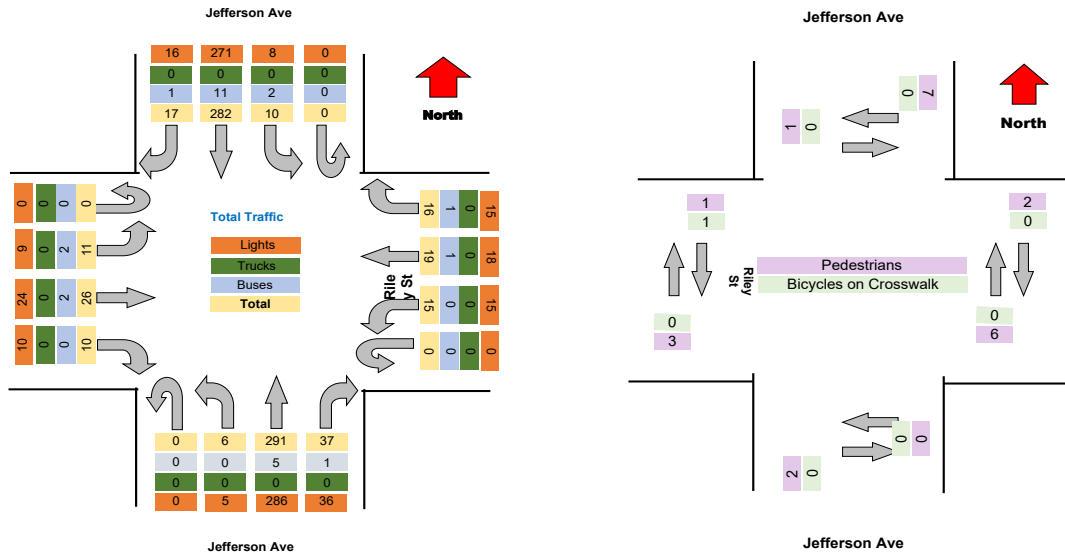



Project : VBH Malta NY  
 Site : Site 4  
 Location : 42.948550, -73.790036  
 Survey Date : 2021-04-28, Wednesday

**Turning Movement Data Plot**

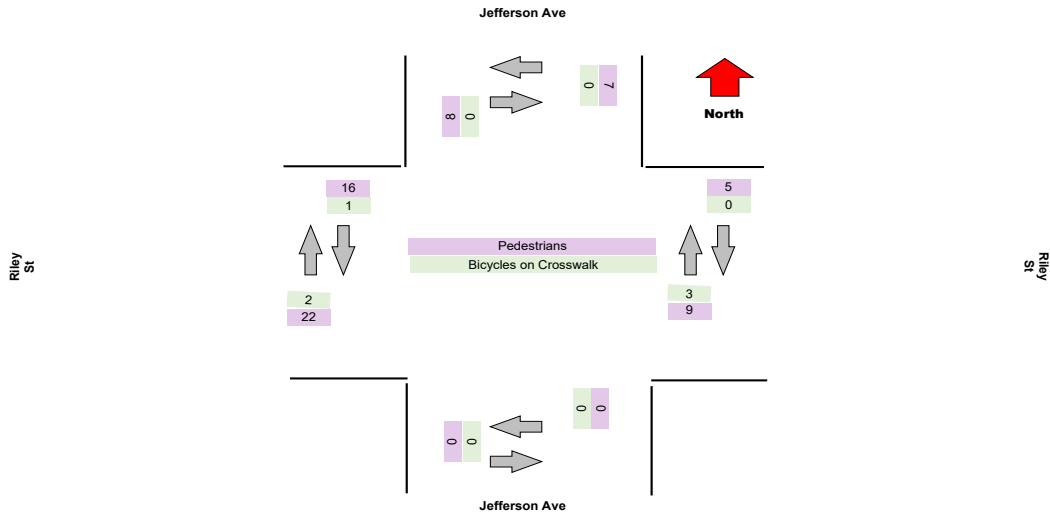
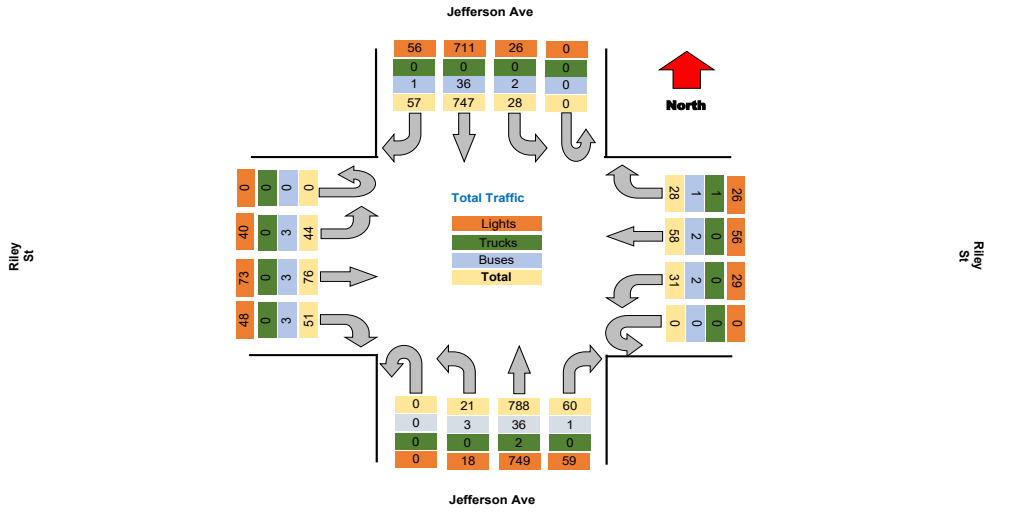



### Turning Movement Peak Hour Data (AM)

7:30:00 AM

Leg Direction	Jefferson Ave					Riley St					Jefferson Ave					Riley St					Total
	Southbound		Westbound			Northbound		Eastbound													
Start Time	Right	Thru	Left	U-Turn	App Total	Peds CW	Peds CCW	Right	Thru	Left	U-Turn	App Total	Peds CW	Peds CCW	Right	Thru	Left	U-Turn	App Total	Peds CW	Peds CCW
7:30:00 AM	1	42	0	0	43	0	0	1	2	0	0	3	1	1	2	29	1	0	34	0	0
7:45:00 AM	0	39	1	0	40	4	1	3	4	3	0	11	0	0	0	47	3	0	50	0	0
8:00:00 AM	4	44	1	0	49	0	1	1	4	1	0	7	1	0	1	40	1	0	43	0	0
8:15:00 AM	4	39	1	0	44	0	0	0	5	0	0	5	0	0	4	47	1	0	53	0	0
<b>Grand Total</b>	<b>9</b>	<b>164</b>	<b>3</b>	<b>0</b>	<b>176</b>	<b>4</b>	<b>2</b>	<b>5</b>	<b>15</b>	<b>4</b>	<b>0</b>	<b>25</b>	<b>2</b>	<b>2</b>	<b>7</b>	<b>153</b>	<b>6</b>	<b>0</b>	<b>160</b>	<b>0</b>	<b>0</b>
<b>% Approach</b>	5.1%	93.2%	1.7%	0.0%	0.0%	0.0%	0.0%	19.2%	57.7%	15.4%	0.0%	0.0%	0.0%	0.0%	3.9%	90.6%	3.3%	0.0%	0.0%	0.0%	0.0%
<b>% Total</b>	2.1%	38.3%	0.7%	0.0%	41.1%	0.0%	0.0%	1.2%	3.5%	0.9%	0.0%	6.1%	0.0%	0.0%	1.6%	38.1%	1.4%	0.0%	42.1%	0.0%	0.0%
<b>PHF</b>	0.563	0.932	0.750	0.000	0.898	0.000	0.000	0.417	0.750	0.333	0.000	0.591	0.000	0.000	0.438	0.867	0.500	0.000	0.849	0.000	0.000
<b>Lights</b>	9	154	3	0	166	0	0	3	14	3	0	20	0	0	7	146	5	0	158	0	0
<b>% Lights</b>	100.0%	93.9%	100.0%	0.0%	94.3%	0.0%	0.0%	60.0%	93.3%	75.0%	0.0%	76.9%	0.0%	0.0%	100.0%	89.6%	83.3%	0.0%	87.8%	0.0%	0.0%
<b>Trucks</b>	0	0	0	0	0	0	0	1	0	0	0	1	0	0	0	1	0	0	1	0	0
<b>% Trucks</b>	0.0%	0.0%	0.0%	0.0%	0.0%	0.0%	0.0%	20.0%	0.0%	0.0%	0.0%	3.8%	0.0%	0.0%	0.0%	0.6%	0.0%	0.0%	0.6%	0.0%	0.0%
<b>Buses</b>	0	10	0	0	10	0	0	1	1	1	0	3	0	0	0	16	1	0	17	0	0
<b>% Buses</b>	0.0%	6.1%	0.0%	0.0%	0.0%	0.0%	0.0%	20.0%	6.7%	25.0%	0.0%	0.0%	0.0%	0.0%	0.0%	9.8%	16.7%	0.0%	0.0%	0.0%	0.0%
<b>Pedestrians</b>	0	0	0	0	0	4	2	0	0	0	0	2	1	0	0	0	0	0	0	0	7
<b>% Pedestrians</b>	0.0%	0.0%	0.0%	0.0%	0.0%	100.0%	100.0%	0.0%	0.0%	0.0%	0.0%	0.0%	100.0%	50.0%	0.0%	0.0%	0.0%	0.0%	0.0%	0.0%	87.5%
<b>Bicycles on Crosswalk</b>	0	0	0	0	0	0	0	0	0	0	0	0	1	0	0	0	0	0	0	0	1
<b>% Bicycles on Crosswalk</b>	0.0%	0.0%	0.0%	0.0%	0.0%	0.0%	0.0%	0.0%	0.0%	0.0%	0.0%	0.0%	50.0%	0.0%	0.0%	0.0%	0.0%	0.0%	0.0%	0.0%	12.5%

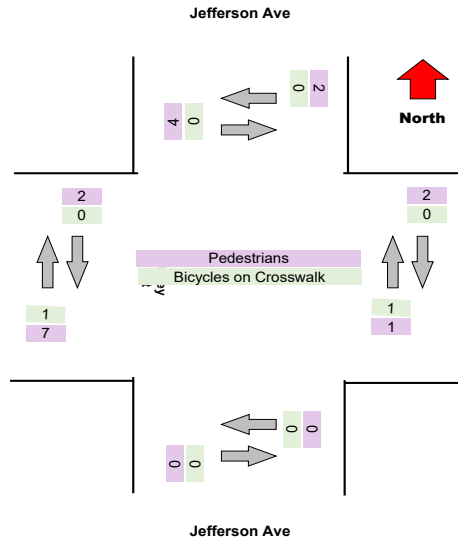
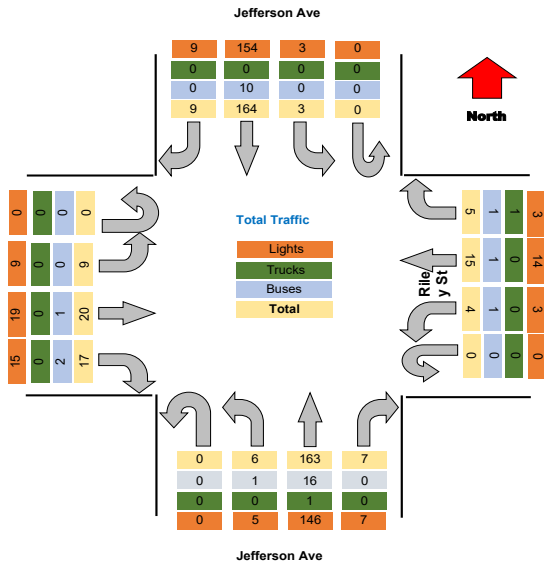

**Turning Movement Peak Hour Data (PM)**

4:15:00 PM

Leg Direction	Jefferson Ave				Riley St				Jefferson Ave				Riley St				Total													
	Southbound				Westbound				Northbound				Eastbound																	
	Right	Thru	Left	U-Turn	App Total	Peds CW	Peds CCW	Right	Thru	Left	U-Turn	App Total	Peds CW	Peds CCW	Right	Thru		Left	U-Turn	App Total	Peds CW	Peds CCW								
4:15:00 PM	5	72	2	0	79	1	1	3	6	7	0	16	0	3	10	71	0	0	81	0	0	5	11	1	0	17	4	2	193	
4:30:00 PM	4	60	4	0	68	0	2	4	3	0	0	7	1	2	7	66	1	0	74	0	0	3	6	1	0	10	1	1	169	
4:45:00 PM	7	65	1	0	73	1	1	1	1	3	0	5	1	0	6	77	3	0	86	0	0	1	4	8	0	13	1	2	177	
5:00:00 PM	5	70	8	0	83	0	0	3	7	1	0	11	0	0	6	65	4	0	75	0	0	2	7	5	0	14	1	2	183	
<b>Grand Total</b>	<b>21</b>	<b>267</b>	<b>15</b>	<b>0</b>	<b>303</b>	<b>2</b>	<b>4</b>	<b>11</b>	<b>17</b>	<b>11</b>	<b>0</b>	<b>39</b>	<b>2</b>	<b>5</b>	<b>29</b>	<b>279</b>	<b>8</b>	<b>0</b>	<b>316</b>	<b>0</b>	<b>0</b>	<b>11</b>	<b>28</b>	<b>15</b>	<b>0</b>	<b>54</b>	<b>7</b>	<b>7</b>	<b>712</b>	
% Approach	6.9%	88.1%	5.0%	0.0%	0.0%	0.0%	0.0%	28.2%	43.6%	28.2%	0.0%	0.0%	0.0%	0.0%	9.2%	88.3%	2.5%	0.0%	0.0%	0.0%	0.0%	20.4%	51.9%	27.8%	0.0%	0.0%	0.0%	0.0%	0.0%	
% Total	2.9%	37.5%	2.1%	0.0%	42.6%	0.0%	0.0%	1.5%	2.4%	1.5%	0.0%	5.5%	0.0%	0.0%	4.1%	39.2%	1.1%	0.0%	44.4%	0.0%	0.0%	1.5%	3.9%	2.1%	0.0%	7.6%	0.0%	0.0%	0.0%	
PHF	0.750	0.927	0.469	0.000	0.913	0.000	0.000	0.688	0.607	0.393	0.000	0.609	0.000	0.000	0.725	0.906	0.500	0.000	0.819	0.000	0.000	0.550	0.636	0.469	0.000	0.794	0.000	0.000	0.922	
Lights	20	258	14	0	292	0	0	11	16	11	0	38	0	0	28	270	7	0	305	0	0	10	27	12	0	49	0	0	684	
% Lights	65.2%	96.6%	93.3%	0.0%	96.4%	0.0%	0.0%	100.0%	94.1%	100.0%	0.0%	97.4%	0.0%	0.0%	96.6%	96.8%	87.5%	0.0%	96.5%	0.0%	0.0%	90.9%	96.4%	80.0%	0.0%	90.7%	0.0%	0.0%	96.1%	
Trucks	0	0	0	0	0	0	0	0	0	0	0	0	0	0	0	0	0	0	0	0	0	0	0	0	0	0	0	0	0	
% Trucks	0.0%	0.0%	0.0%	0.0%	0.0%	0.0%	0.0%	0.0%	0.0%	0.0%	0.0%	0.0%	0.0%	0.0%	0.0%	0.0%	0.0%	0.0%	0.0%	0.0%	0.0%	0.0%	0.0%	0.0%	0.0%	0.0%	0.0%	0.0%	0.0%	
Buses	1	9	1	0	11	0	0	0	1	0	0	1	0	0	1	8	1	0	10	0	0	1	1	3	0	5	0	0	27	
% Buses	4.8%	3.4%	6.7%	0.0%	0.0%	0.0%	0.0%	0.0%	5.9%	0.0%	0.0%	0.0%	0.0%	0.0%	3.4%	2.9%	12.5%	0.0%	0.0%	0.0%	0.0%	9.1%	3.8%	20.0%	0.0%	0.0%	0.0%	0.0%	3.8%	
Pedestrians	0	0	0	0	0	2	4	0	0	0	0	2	4	0	0	0	0	0	0	0	0	0	0	0	0	0	6	6	0	
% Pedestrians	0.0%	0.0%	0.0%	0.0%	0.0%	100.0%	100.0%	0.0%	0.0%	0.0%	0.0%	0.0%	100.0%	80.0%	0.0%	0.0%	0.0%	0.0%	0.0%	0.0%	0.0%	0.0%	0.0%	0.0%	0.0%	0.0%	0.0%	85.7%	85.7%	0.0%
Bicycles on Crosswalk	0	0	0	0	0	0	0	0	0	0	0	1	0	0	0	0	0	0	0	0	0	0	0	0	0	0	1	1	0	
% Bicycles on Crosswalk	0.0%	0.0%	0.0%	0.0%	0.0%	0.0%	0.0%	0.0%	0.0%	0.0%	0.0%	0.0%	0.0%	20.0%	0.0%	0.0%	0.0%	0.0%	0.0%	0.0%	0.0%	0.0%	0.0%	0.0%	0.0%	0.0%	14.3%	14.3%	0.0%	

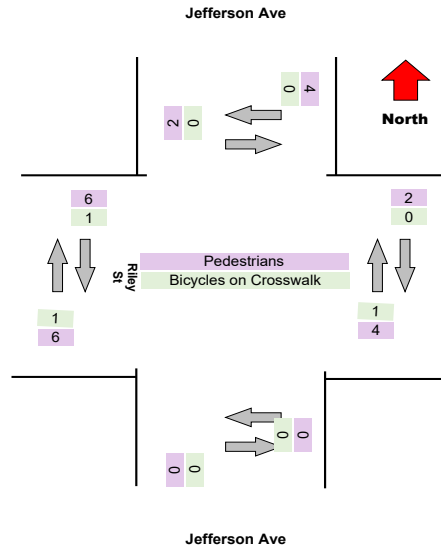
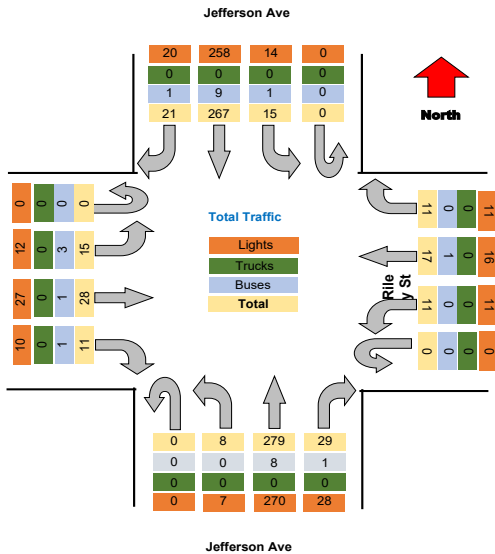



Project : VBH Malta NY  
 Site : Site 4  
 Location : 42.948550, -73.790036  
 Survey Date : 2021-04-28, Wednesday

### Turning Movement Data Plot

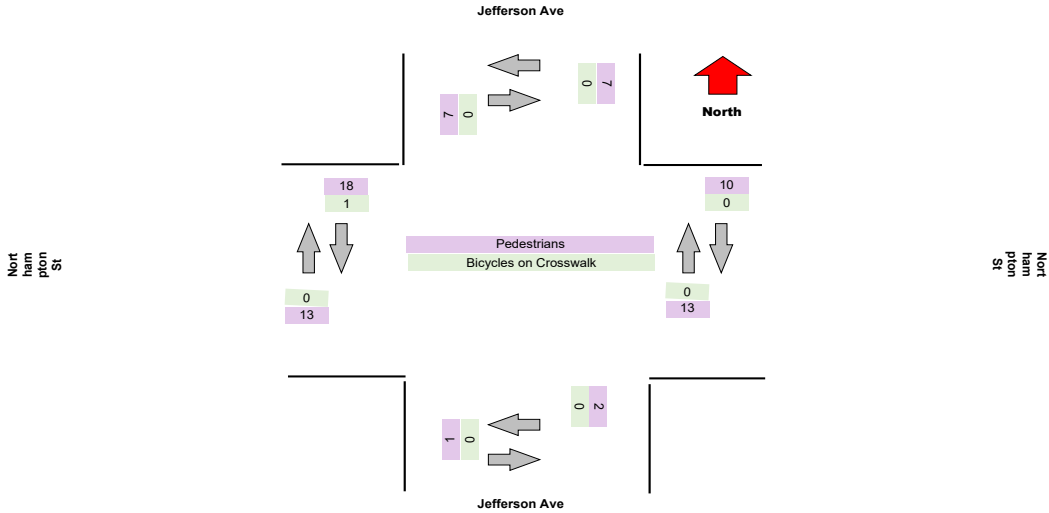
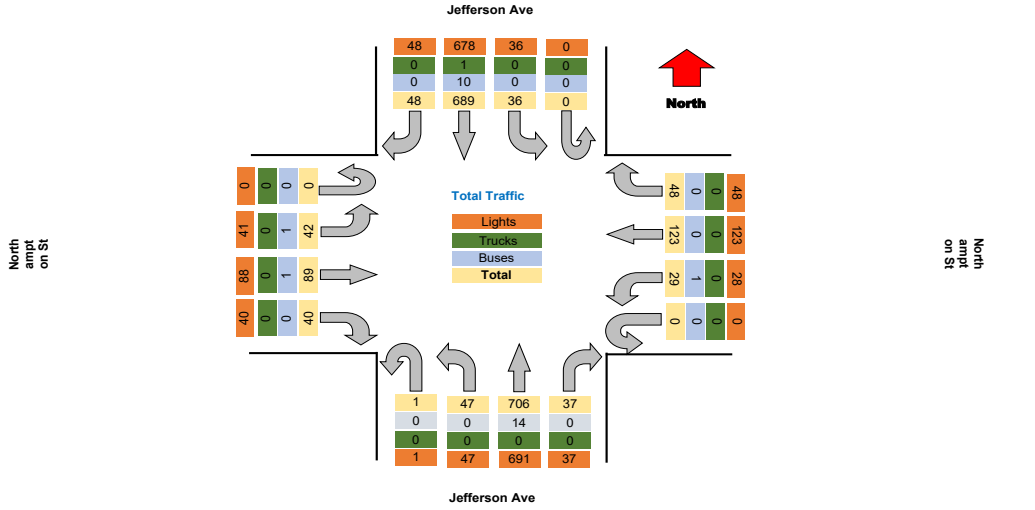

Project : VBH Malta NY  
Site : Site 4  
Location : 42.948550, -73.790036  
Survey Date : 2021-04-28, Wednesday

TSTData.com

**Turning Movement Peak Hour Data (AM)**

7:30:00 AM

Leg Direction	Jefferson Ave						Northampton St						Jefferson Ave						Northampton St						Total					
	Southbound			Northbound			Westbound			Eastbound			Northbound			Eastbound														
Start Time	Right	Thru	Left	U-Turn	App Total	Peds CW	Peds CCW	Right	Thru	Left	U-Turn	App Total	Peds CW	Peds CCW	Right	Thru	Left	U-Turn	App Total	Peds CW	Peds CCW	Right	Thru	Left	U-Turn	App Total	Peds CW	Peds CCW		
7:30:00 AM	3	21	0	0	24	0	0	1	5	2	0	8	0	1	1	24	4	0	0	30	0	0	1	4	0	0	5	2	0	67
7:45:00 AM	0	25	3	0	28	0	0	1	8	0	0	9	0	0	2	26	4	0	0	32	0	0	4	3	1	0	8	0	2	77
8:00:00 AM	1	32	2	0	35	0	0	3	13	1	0	17	1	0	2	31	4	0	0	38	0	0	2	3	1	0	6	0	1	96
8:15:00 AM	4	44	3	0	48	0	0	5	13	1	0	20	0	0	1	23	3	0	0	29	1	0	3	6	1	0	10	0	0	108
<b>Grand Total</b>	<b>8</b>	<b>117</b>	<b>8</b>	<b>0</b>	<b>135</b>	<b>0</b>	<b>0</b>	<b>10</b>	<b>39</b>	<b>4</b>	<b>0</b>	<b>54</b>	<b>1</b>	<b>0</b>	<b>6</b>	<b>104</b>	<b>15</b>	<b>0</b>	<b>128</b>	<b>1</b>	<b>0</b>	<b>10</b>	<b>16</b>	<b>3</b>	<b>0</b>	<b>29</b>	<b>2</b>	<b>3</b>	<b>348</b>	
<b>% Approach</b>	5.9%	88.1%	5.9%	0.0%	<b>0.0%</b>	0.0%	0.0%	18.5%	72.2%	7.4%	0.0%	<b>0.0%</b>	0.0%	0.0%	4.7%	81.3%	11.7%	0.0%	<b>0.0%</b>	0.0%	0.0%	34.5%	55.2%	10.3%	0.0%	<b>0.0%</b>	0.0%	0.0%	0.0%	
<b>% Total</b>	2.3%	34.4%	2.3%	0.0%	<b>38.0%</b>	0.0%	0.0%	2.9%	11.3%	1.2%	0.0%	<b>15.6%</b>	0.0%	0.0%	1.7%	30.1%	4.3%	0.0%	<b>37.0%</b>	0.0%	0.0%	2.9%	4.6%	0.9%	0.0%	<b>8.4%</b>	0.0%	0.0%	0.0%	
<b>PHF</b>	0.500	0.728	0.667	0.000	<b>0.703</b>	0.000	0.000	0.500	0.750	0.500	0.000	<b>0.675</b>	0.000	0.000	0.750	0.839	0.938	0.000	<b>0.842</b>	0.000	0.000	0.625	0.667	0.750	0.000	<b>0.725</b>	0.000	0.000	<b>0.816</b>	
<b>Lights</b>	8	117	8	0	133	0	0	10	39	4	0	53	0	0	6	100	15	0	121	0	0	10	15	2	0	27	0	0	334	
<b>% Lights</b>	100.0%	98.3%	100.0%	0.0%	<b>98.5%</b>	0.0%	0.0%	100.0%	100.0%	100.0%	0.0%	<b>98.1%</b>	0.0%	0.0%	100.0%	96.2%	100.0%	0.0%	<b>94.5%</b>	0.0%	0.0%	100.0%	93.8%	66.7%	0.0%	<b>93.1%</b>	0.0%	0.0%	<b>96.5%</b>	
<b>Trucks</b>	0	0	0	0	0	0	0	0	0	0	0	0	0	0	0	0	0	0	0	0	0	0	0	0	0	0	0	0	0	0
<b>% Trucks</b>	0.0%	0.0%	0.0%	0.0%	<b>0.0%</b>	0.0%	0.0%	0.0%	0.0%	0.0%	0.0%	<b>0.0%</b>	0.0%	0.0%	0.0%	0.0%	0.0%	0.0%	<b>0.0%</b>	0.0%	0.0%	0.0%	0.0%	0.0%	0.0%	<b>0.0%</b>	0.0%	0.0%	<b>0.0%</b>	
<b>Buses</b>	0	2	0	0	2	0	0	0	0	0	0	0	0	0	0	4	0	0	4	0	0	0	1	1	0	2	0	0	8	
<b>% Buses</b>	0.0%	1.7%	0.0%	0.0%	<b>0.0%</b>	0.0%	0.0%	0.0%	0.0%	0.0%	0.0%	<b>0.0%</b>	0.0%	0.0%	0.0%	3.8%	0.0%	0.0%	<b>0.0%</b>	0.0%	0.0%	0.0%	6.3%	33.3%	0.0%	<b>0.0%</b>	0.0%	0.0%	<b>2.3%</b>	
<b>Pedestrians</b>	0	0	0	0	0	0	0	0	0	0	0	0	1	2	0	0	0	0	0	1	0	0	0	0	0	0	2	3	0	
<b>% Pedestrians</b>	0.0%	0.0%	0.0%	0.0%	<b>0.0%</b>	0.0%	100.0%	0.0%	0.0%	0.0%	0.0%	<b>0.0%</b>	100.0%	100.0%	0.0%	0.0%	0.0%	0.0%	<b>0.0%</b>	100.0%	0.0%	0.0%	0.0%	0.0%	0.0%	<b>0.0%</b>	100.0%	100.0%	<b>0.0%</b>	
<b>Bicycles on Crosswalk</b>	0	0	0	0	0	0	0	0	0	0	0	0	0	0	0	0	0	0	0	0	0	0	0	0	0	0	0	0	0	0
<b>% Bicycles on Crosswalk</b>	0.0%	0.0%	0.0%	0.0%	<b>0.0%</b>	0.0%	0.0%	0.0%	0.0%	0.0%	0.0%	<b>0.0%</b>	0.0%	0.0%	0.0%	0.0%	0.0%	0.0%	<b>0.0%</b>	0.0%	0.0%	0.0%	0.0%	0.0%	0.0%	<b>0.0%</b>	0.0%	0.0%	<b>0.0%</b>	

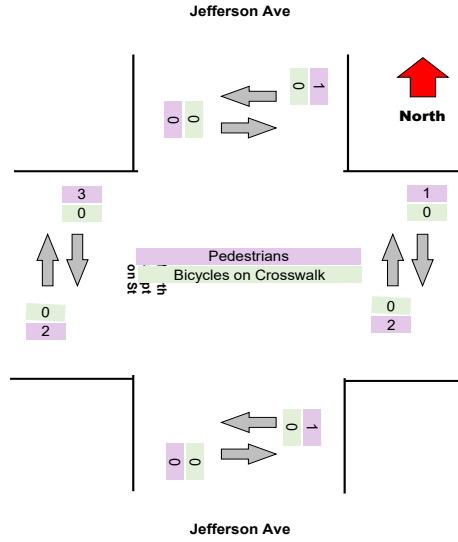
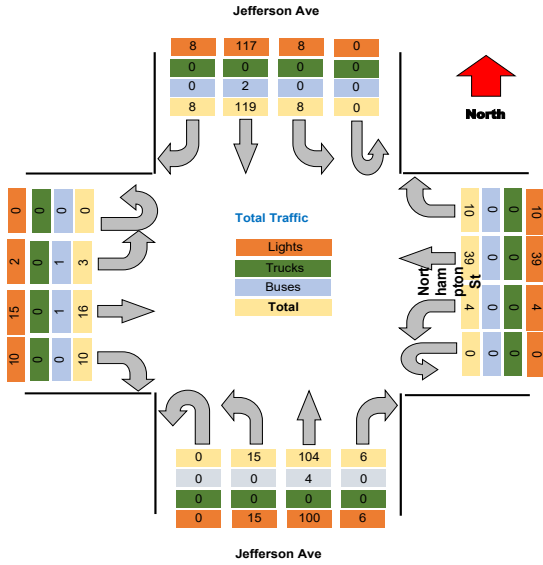

**Turning Movement Peak Hour Data (PM)**

4:15:00 PM

Leg Direction	Jefferson Ave								Northampton St								Total															
	Southbound				Westbound				Northbound				Eastbound																			
	Right	Thru	Left	U-Turn	App Total	Peds CW	Peds CCW		Right	Thru	Left	U-Turn	App Total	Peds CW	Peds CCW			Right	Thru	Left	U-Turn	App Total	Peds CW	Peds CCW								
4:15:00 PM	4	64	2	0	70	0	1		8	9	2	0	19	0	1		2	50	3	0	55	0	0		4	11	8	0	23	0	0	167
4:30:00 PM	3	72	4	0	79	3	0		11	4	2	0	17	2	1		2	68	4	0	74	0	0		3	17	4	0	24	1	2	184
4:45:00 PM	5	59	4	0	68	0	2		2	11	5	0	18	0	3		4	70	6	0	80	1	0		3	13	4	0	20	1	1	186
5:00:00 PM	4	49	4	0	57	1	0		4	14	3	0	21	2	2		7	79	3	0	89	0	1		4	6	5	0	15	0	1	182
<b>Grand Total</b>	16	244	14	0	274	4	3		25	38	12	0	75	4	7		15	267	16	0	298	1	1		14	37	21	0	72	2	4	719
<b>% Approach</b>	5.8%	89.1%	5.1%	0.0%	0.0%	0.0%	0.0%		33.3%	50.7%	16.0%	0.0%	0.0%	0.0%	0.0%		5.0%	89.6%	5.4%	0.0%	0.0%	0.0%	0.0%		19.4%	51.4%	29.2%	0.0%	0.0%	0.0%	0.0%	0.0%
<b>% Total</b>	2.2%	33.9%	1.9%	0.0%	38.1%	0.0%	0.0%		3.5%	5.3%	1.7%	0.0%	10.4%	0.0%	0.0%		2.1%	37.1%	2.2%	0.0%	41.4%	0.0%	0.0%		1.9%	5.1%	2.9%	0.0%	10.0%	0.0%	0.0%	
<b>PHF</b>	0.800	0.847	0.875	0.000	0.867	0.000	0.000		0.568	0.679	0.600	0.000	0.893	0.000	0.000		0.536	0.845	0.667	0.000	0.837	0.000	0.000		0.875	0.712	0.656	0.000	0.783	0.000	0.000	0.966
<b>Lights</b>	16	240	14	0	270	0	0		25	38	11	0	74	0	0		15	261	16	0	292	0	0		14	37	21	0	72	0	0	708
<b>% Lights</b>	100.0%	98.4%	100.0%	0.0%	98.5%	0.0%	0.0%		100.0%	100.0%	91.7%	0.0%	98.7%	0.0%	0.0%		100.0%	97.8%	100.0%	0.0%	98.0%	0.0%	0.0%		100.0%	100.0%	100.0%	0.0%	100.0%	0.0%	0.0%	98.5%
<b>Trucks</b>	0	1	0	0	1	0	0		0	0	0	0	0	0	0		0	0	0	0	0	0	0		0	0	0	0	0	0	0	1
<b>% Trucks</b>	0.0%	0.4%	0.0%	0.0%	0.4%	0.0%	0.0%		0.0%	0.0%	0.0%	0.0%	0.0%	0.0%	0.0%		0.0%	0.0%	0.0%	0.0%	0.0%	0.0%	0.0%		0.0%	0.0%	0.0%	0.0%	0.0%	0.0%	0.0%	0.1%
<b>Buses</b>	0	3	0	0	3	0	0		0	1	0	0	1	0	0		0	5	0	0	5	0	0		0	0	0	0	0	0	0	9
<b>% Buses</b>	0.0%	1.2%	0.0%	0.0%	0.0%	0.0%	0.0%		0.0%	0.0%	8.3%	0.0%	0.0%	0.0%	0.0%		0.0%	1.9%	0.0%	0.0%	0.0%	0.0%	0.0%		0.0%	0.0%	0.0%	0.0%	0.0%	0.0%	0.0%	1.3%
<b>Pedestrians</b>	0	0	0	0	0	4	3		0	0	0	0	0	4	7		0	0	0	0	1	1	0		0	0	0	0	0	2	4	0
<b>% Pedestrians</b>	0.0%	0.0%	0.0%	0.0%	0.0%	100.0%	100.0%		0.0%	0.0%	0.0%	0.0%	0.0%	100.0%	100.0%		0.0%	0.0%	0.0%	0.0%	0.0%	100.0%	100.0%		0.0%	0.0%	0.0%	0.0%	0.0%	100.0%	100.0%	0.0%
<b>Bicycles on Crosswalk</b>	0	0	0	0	0	0	0		0	0	0	0	0	0	0		0	0	0	0	0	0	0		0	0	0	0	0	0	0	0
<b>% Bicycles on Crosswalk</b>	0.0%	0.0%	0.0%	0.0%	0.0%	0.0%	0.0%		0.0%	0.0%	0.0%	0.0%	0.0%	0.0%	0.0%		0.0%	0.0%	0.0%	0.0%	0.0%	0.0%	0.0%		0.0%	0.0%	0.0%	0.0%	0.0%	0.0%	0.0%	0.0%

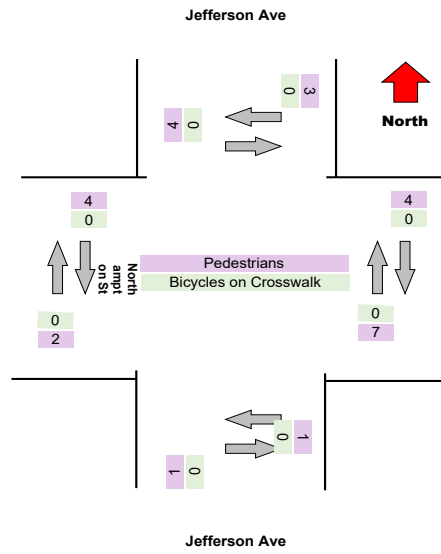
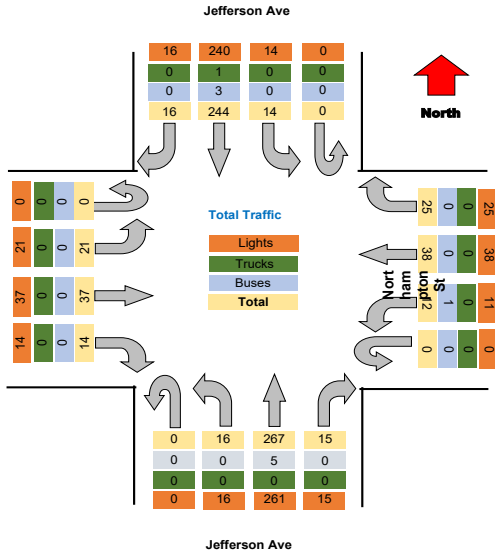



Project : VBH Malta NY  
 Site : Site 4  
 Location : 42.948550, -73.790036  
 Survey Date : 2021-04-28, Wednesday

### Turning Movement Data Plot

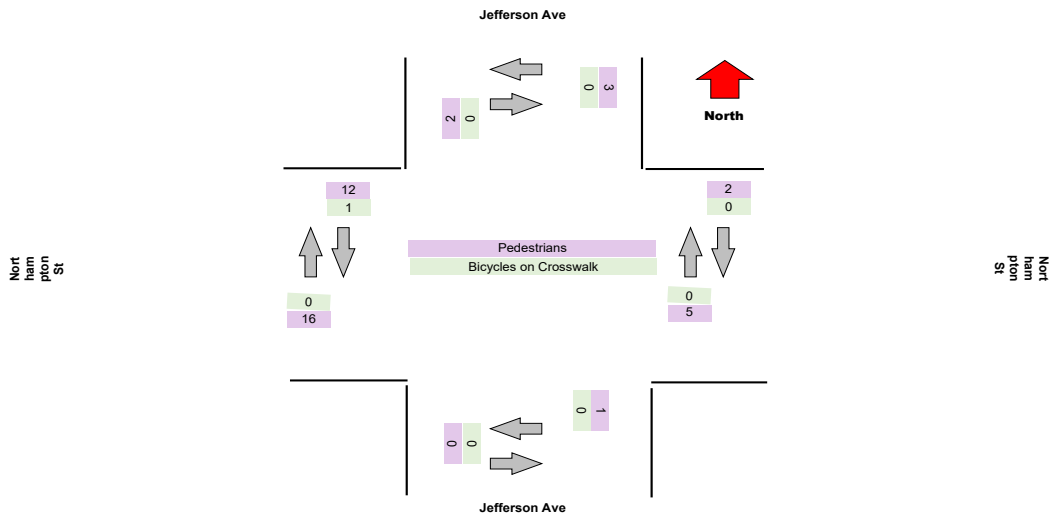
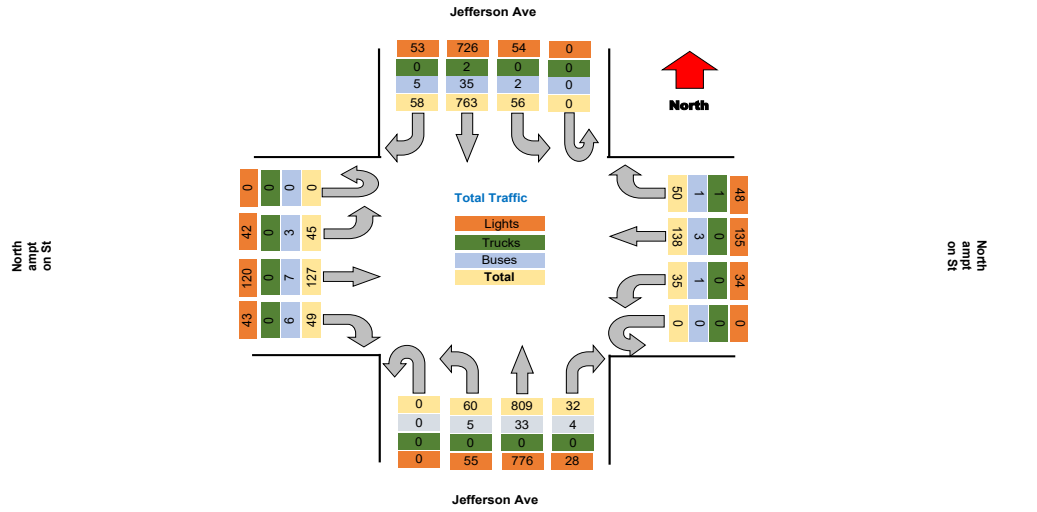



Project : VBH Malta NY  
Site : Site 4  
Location : 42.948550, -73.790036  
Survey Date : 2021-04-28, Wednesday

TSTData.com

**Turning Movement Peak Hour Data (AM)**

7:30:00 AM

Leg Direction	Jefferson Ave					Northampton St					Jefferson Ave					Northampton St					Total									
	Right	Thru	Left	U-Turn	App Total	Peds CW	Peds CCW	Right	Thru	Left	U-Turn	App Total	Peds CW	Peds CCW	Right	Thru	Left	U-Turn	App Total	Peds CW		Peds CCW								
7:30:00 AM	4	36	0	0	40	0	1	1	7	5	0	14	0	0	0	32	3	0	35	0	0	10	1	0	99					
7:45:00 AM	3	60	3	0	66	0	0	0	15	4	0	19	0	0	2	40	1	0	43	0	0	1	9	0	10	4	0	138		
8:00:00 AM	2	56	1	0	59	0	0	4	14	1	0	19	0	1	2	41	4	0	48	0	0	4	8	0	14	0	1	140		
8:15:00 AM	2	33	2	0	37	0	0	4	19	2	0	24	0	0	0	42	5	0	47	0	0	4	8	0	12	2	1	120		
<b>Grand Total</b>	<b>11</b>	<b>185</b>	<b>6</b>	<b>0</b>	<b>202</b>	<b>0</b>	<b>1</b>	<b>9</b>	<b>54</b>	<b>12</b>	<b>0</b>	<b>75</b>	<b>0</b>	<b>1</b>	<b>4</b>	<b>155</b>	<b>13</b>	<b>0</b>	<b>173</b>	<b>0</b>	<b>0</b>	<b>6</b>	<b>34</b>	<b>8</b>	<b>46</b>	<b>7</b>	<b>2</b>	<b>497</b>		
% Approach	5.4%	91.6%	3.0%	0.0%	0.0%	0.0%	0.0%	11.8%	71.1%	15.8%	0.0%	0.0%	0.0%	0.0%	2.3%	89.6%	7.5%	0.0%	0.0%	0.0%	0.0%	13.0%	73.9%	13.0%	0.0%	0.0%	0.0%	0.0%		
% Total	2.2%	37.2%	1.2%	0.0%	46.6%	0.0%	0.0%	1.8%	10.9%	2.4%	0.0%	15.3%	0.0%	0.0%	0.8%	31.2%	2.6%	0.0%	34.8%	0.0%	0.0%	1.2%	6.8%	1.2%	0.0%	9.3%	0.0%	0.0%		
PHF	0.688	0.771	0.500	0.000	0.765	0.000	0.000	0.563	0.750	0.600	0.000	0.792	0.000	0.000	0.500	0.923	0.650	0.000	0.901	0.000	0.000	0.375	0.944	0.375	0.000	0.821	0.000	0.000	0.888	
Lights	8	171	5	0	184	0	0	9	53	11	0	73	0	0	4	139	11	0	154	0	0	6	31	5	0	42	0	0	463	
% Lights	72.7%	92.4%	83.3%	0.0%	91.1%	0.0%	0.0%	100.0%	98.1%	91.7%	0.0%	96.1%	0.0%	0.0%	100.0%	89.7%	84.6%	0.0%	89.0%	0.0%	0.0%	100.0%	91.2%	83.3%	0.0%	91.3%	0.0%	0.0%	91.1%	
Trucks	0	1	0	0	1	0	0	0	0	0	0	0	0	0	0	0	0	0	0	0	0	0	0	0	0	0	0	0	1	
% Trucks	0.0%	0.5%	0.0%	0.0%	0.5%	0.0%	0.0%	0.0%	0.0%	0.0%	0.0%	0.0%	0.0%	0.0%	0.0%	0.0%	0.0%	0.0%	0.0%	0.0%	0.0%	0.0%	0.0%	0.0%	0.0%	0.0%	0.0%	0.0%	0.2%	
Buses	3	13	1	0	17	0	0	0	1	1	0	2	0	0	0	16	2	0	18	0	0	0	3	1	0	4	0	0	41	
% Buses	27.3%	7.0%	16.7%	0.0%	8.4%	0.0%	0.0%	0.0%	1.9%	8.3%	0.0%	2.7%	0.0%	0.0%	0.0%	10.3%	15.4%	0.0%	10.4%	0.0%	0.0%	0.0%	8.8%	16.7%	0.0%	9.1%	0.0%	0.0%	8.2%	
Pedestrians	0	0	0	0	0	0	1	0	0	0	0	0	1	0	0	0	0	0	0	0	0	0	0	0	0	0	7	2	0	
% Pedestrians	0.0%	0.0%	0.0%	0.0%	0.0%	0.0%	100.0%	0.0%	0.0%	0.0%	0.0%	0.0%	0.0%	0.0%	0.0%	0.0%	0.0%	0.0%	0.0%	0.0%	0.0%	0.0%	0.0%	0.0%	0.0%	0.0%	0.0%	100.0%	100.0%	0.0%
Bicycles on Crosswalk	0	0	0	0	0	0	0	0	0	0	0	0	0	0	0	0	0	0	0	0	0	0	0	0	0	0	0	0	0	
% Bicycles on Crosswalk	0.0%	0.0%	0.0%	0.0%	0.0%	0.0%	0.0%	0.0%	0.0%	0.0%	0.0%	0.0%	0.0%	0.0%	0.0%	0.0%	0.0%	0.0%	0.0%	0.0%	0.0%	0.0%	0.0%	0.0%	0.0%	0.0%	0.0%	0.0%	0.0%	

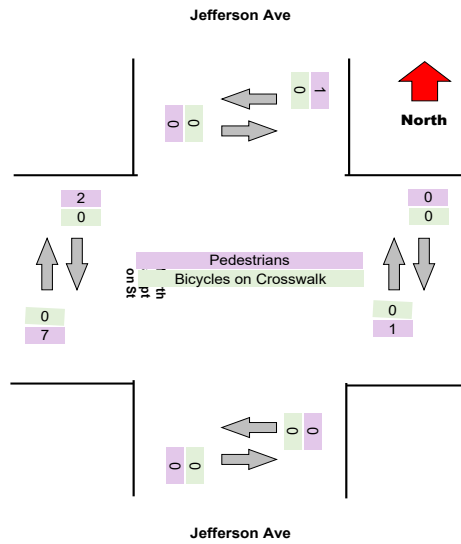
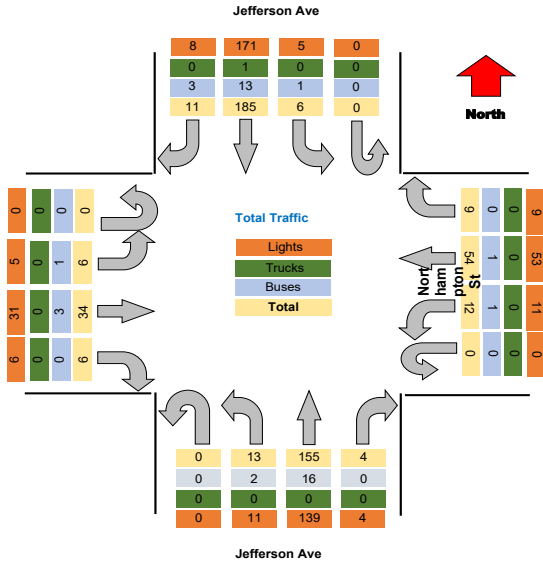

**Turning Movement Peak Hour Data (PM)**

4:15:00 PM

Leg Direction	Jefferson Ave								Northampton St								Jefferson Ave								Northampton St								Total
	Southbound				Northbound				Westbound				Eastbound				Northbound				Eastbound												
	Right	Thru	Left	U-Turn	App Total	Peds CW	Peds CCW		Right	Thru	Left	U-Turn	App Total	Peds CW	Peds CCW		Right	Thru	Left	U-Turn	App Total	Peds CW	Peds CCW		Right	Thru	Left	U-Turn	App Total	Peds CW	Peds CCW		
4:15:00 PM	6	63	9	0	78	0	0		5	12	1	0	18	0	0		4	72	3	0	79	0	0		6	5	5	0	16	0	0		191
4:30:00 PM	7	77	7	0	91	0	1		5	6	6	0	17	0	1		3	59	3	0	65	0	0		8	14	3	0	25	0	1		198
4:45:00 PM	7	47	4	0	58	0	0		4	10	3	0	17	2	1		2	79	7	0	87	0	0		2	10	5	0	17	1	0		171
5:00:00 PM	8	72	5	0	85	0	0		4	11	1	0	16	0	0		2	79	6	0	87	0	0		6	12	5	0	23	3	1		211
<b>Grand Total</b>	<b>28</b>	<b>259</b>	<b>25</b>	<b>0</b>	<b>312</b>	<b>0</b>	<b>0</b>		<b>18</b>	<b>39</b>	<b>11</b>	<b>0</b>	<b>67</b>	<b>2</b>	<b>2</b>		<b>12</b>	<b>279</b>	<b>19</b>	<b>0</b>	<b>310</b>	<b>0</b>	<b>0</b>		<b>22</b>	<b>41</b>	<b>18</b>	<b>0</b>	<b>81</b>	<b>4</b>	<b>2</b>		<b>771</b>
% Approach	9.0%	83.0%	8.0%	0.0%	0.0%	0.0%	0.0%		29.5%	57.4%	16.2%	0.0%	0.0%	0.0%	0.0%		3.9%	90.0%	6.1%	0.0%	0.0%	0.0%	0.0%		27.2%	50.6%	22.2%	0.0%	0.0%	0.0%	0.0%		
% Total	3.6%	33.6%	3.2%	0.0%	40.5%	0.0%	0.0%		2.3%	5.1%	1.4%	0.0%	8.8%	0.0%	0.0%		1.6%	36.2%	2.5%	0.0%	40.2%	0.0%	0.0%		2.9%	5.3%	2.3%	0.0%	10.5%	0.0%	0.0%		
PHF	0.875	0.841	0.694	0.000	0.857	0.000	0.000		0.900	0.813	0.458	0.000	0.944	0.000	0.000		0.750	0.883	0.679	0.000	0.891	0.000	0.000		0.688	0.732	0.900	0.000	0.810	0.000	0.000		0.914
Lights	27	251	24	0	302	0	0		18	38	11	0	67	0	0		9	273	19	0	301	0	0		18	40	17	0	75	0	0		745
% Lights	96.4%	96.9%	96.0%	0.0%	96.8%	0.0%	0.0%		100.0%	97.4%	100.0%	0.0%	98.5%	0.0%	0.0%		75.0%	97.8%	100.0%	0.0%	97.1%	0.0%	0.0%		81.8%	97.6%	94.4%	0.0%	92.6%	0.0%	0.0%		96.6%
Trucks	0	0	0	0	0	0	0		0	0	0	0	0	0	0		0	0	0	0	0	0	0		0	0	0	0	0	0	0		0
% Trucks	0.0%	0.0%	0.0%	0.0%	0.0%	0.0%	0.0%		0.0%	0.0%	0.0%	0.0%	0.0%	0.0%	0.0%		0.0%	0.0%	0.0%	0.0%	0.0%	0.0%	0.0%		0.0%	0.0%	0.0%	0.0%	0.0%	0.0%	0.0%		0.0%
Buses	1	8	1	0	10	0	0		0	1	0	0	1	0	0		3	6	0	0	9	0	0		4	1	1	0	6	0	0		26
% Buses	3.6%	3.1%	4.0%	0.0%	0.0%	0.0%	0.0%		0.0%	2.6%	0.0%	0.0%	0.0%	0.0%	0.0%		25.0%	2.2%	0.0%	0.0%	0.0%	0.0%	0.0%		18.2%	2.4%	5.6%	0.0%	0.0%	0.0%	0.0%		3.4%
Pedestrians	0	0	0	0	0	0	0		0	0	0	0	2	2	0		0	0	0	0	0	0	0		0	0	0	0	0	4	2		6
% Pedestrians	0.0%	0.0%	0.0%	0.0%	0.0%	0.0%	100.0%		0.0%	0.0%	0.0%	0.0%	0.0%	100.0%	100.0%		0.0%	0.0%	0.0%	0.0%	0.0%	0.0%	0.0%		0.0%	0.0%	0.0%	0.0%	0.0%	100.0%	100.0%		0.8%
Bicycles on Crosswalk	0	0	0	0	0	0	0		0	0	0	0	0	0	0		0	0	0	0	0	0	0		0	0	0	0	0	0	0		0
% Bicycles on Crosswalk	0.0%	0.0%	0.0%	0.0%	0.0%	0.0%	0.0%		0.0%	0.0%	0.0%	0.0%	0.0%	0.0%	0.0%		0.0%	0.0%	0.0%	0.0%	0.0%	0.0%	0.0%		0.0%	0.0%	0.0%	0.0%	0.0%	0.0%	0.0%		0.0%

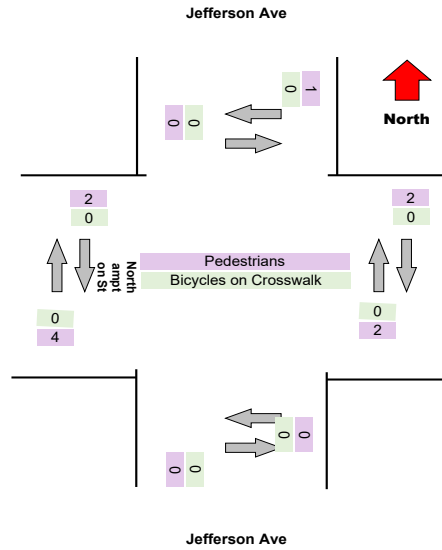
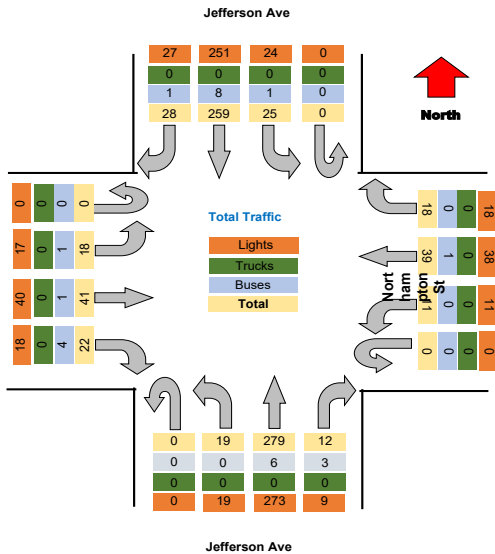

Project : VBH Malta NY  
 Site : Site 4  
 Location : 42.948550, -73.790036

TSTData.com

Survey Date : 2021-04-28, Wednesday

Project	LaBella
Project Code	LaBella
Site Name	35
Legs and Movements	All Processed Legs & Move
Bin Size	15 minutes
Survey Date	2021-11-04, Thursday
Location	35
Latitude and Longitude	42.907459, -78.853974

	Start	End	PHF
Forced Peak AM	2021/11/04 07:30:00	2021/11/04 08:30:00	0.89
Forced Peak PM	2021/11/04 16:30:00	2021/11/04 17:30:00	0.97
AM Peak	2021/11/04 07:30:00	2021/11/04 08:30:00	0.89
PM Peak	2021/11/04 16:15:00	2021/11/04 17:15:00	0.93

### Turning Movement Data

Leg Direction	Jefferson Ave							Northampton St							Jefferson Ave							Northampton St							Total
	Southbound							Westbound							Northbound							Eastbound							
	Right	Thru	Left	U-Turn	App Total	Peds CV	Peds CCV	Right	Thru	Left	U-Turn	App Total	Peds CV	Peds CCV	Right	Thru	Left	U-Turn	App Total	Peds CV	Peds CCV	Right	Thru	Left	U-Turn	App Total	Peds CV	Peds CCV	
6:30:00 AM	1	11	3	0	15	0	0	3	3	1	0	7	0	0	0	14	1	0	15	0	0	1	3	1	0	5	0	0	42
6:45:00 AM	1	9	0	0	10	0	0	0	4	0	0	4	0	0	0	23	2	0	26	0	0	1	2	0	0	3	1	0	43
Hourly Total	2	20	3	0	25	0	0	3	7	1	0	11	0	0	0	37	3	0	41	0	0	2	5	1	0	8	1	0	85
7:00:00 AM	0	17	1	0	18	0	0	1	4	3	0	8	0	0	2	32	3	0	37	0	0	0	2	2	0	4	3	1	67
7:15:00 AM	2	33	1	0	36	0	0	0	9	3	0	12	1	0	1	26	1	0	29	0	0	2	4	0	0	6	3	2	83
7:30:00 AM	2	36	2	0	40	0	1	0	9	2	0	12	0	0	1	32	3	0	36	0	0	2	6	1	0	9	0	0	97
7:45:00 AM	6	43	2	0	51	0	0	1	15	0	0	16	1	0	2	49	7	0	59	0	0	0	13	2	0	15	2	0	141
Hourly Total	10	129	6	0	145	0	1	2	37	8	0	48	2	0	6	139	14	0	161	0	0	4	25	5	0	34	8	3	388
8:00:00 AM	3	44	2	0	49	0	0	1	17	5	0	23	0	0	2	41	4	0	47	0	2	3	10	1	0	14	0	0	133
8:15:00 AM	3	37	2	0	42	0	0	3	19	3	0	25	1	1	2	43	9	0	56	0	0	7	11	3	0	21	1	2	144
Hourly Total	6	81	4	0	91	0	0	4	36	8	0	48	1	1	4	84	13	0	103	0	2	10	21	4	0	35	1	2	277
4:00:00 PM	4	75	6	0	85	0	0	3	12	4	0	19	0	0	5	73	4	0	82	0	0	3	14	3	0	20	1	0	206
4:15:00 PM	9	70	5	0	84	0	0	2	17	0	0	19	0	3	6	73	2	0	81	0	0	2	13	7	0	22	3	0	206
4:30:00 PM	4	65	0	0	69	1	0	4	13	4	0	21	1	1	0	66	3	0	69	0	0	5	19	4	0	28	0	0	187
4:45:00 PM	6	52	4	0	62	0	0	7	12	1	0	20	0	1	3	73	3	0	79	0	0	5	15	6	0	26	1	2	187
Hourly Total	23	262	15	0	300	1	0	16	54	9	0	79	1	5	14	255	12	0	311	0	0	15	61	20	0	96	5	2	756
5:00:00 PM	6	71	4	0	81	0	0	4	10	2	0	16	0	0	5	64	4	1	74	0	0	4	8	6	0	18	0	1	189
5:15:00 PM	1	64	5	0	70	0	0	6	8	4	0	18	0	0	4	58	2	0	64	0	1	1	13	3	0	17	1	1	169
5:30:00 PM	3	55	7	0	65	0	0	6	6	4	0	16	0	0	3	54	4	0	61	0	0	4	10	1	0	15	0	1	157
5:45:00 PM	2	61	4	0	67	0	0	6	8	1	0	15	1	0	2	56	6	0	64	0	0	4	8	0	0	12	1	2	158
Hourly Total	12	251	20	0	283	0	0	22	32	11	0	65	1	0	14	232	16	1	263	0	1	13	39	10	0	62	2	5	673
Grand Total	53	743	48	0	844	1	1	47	166	37	0	251	5	7	38	777	58	1	879	0	3	44	151	40	0	235	17	12	2209
% Approach	6.3%	88.0%	5.7%	0.0%	0.0%	0.0%	0.0%	18.7%	66.1%	14.7%	0.0%	0.0%	0.0%	0.0%	4.3%	88.4%	6.6%	0.1%	0.0%	0.0%	0.0%	18.7%	64.3%	17.0%	0.0%	0.0%	0.0%	0.0%	0.0%
% Total	2.4%	33.6%	2.2%	0.0%	38.2%	0.0%	0.0%	2.1%	7.5%	1.7%	0.0%	11.4%	0.0%	0.0%	1.7%	35.2%	2.6%	0.0%	39.8%	0.0%	0.0%	2.0%	6.8%	1.8%	0.0%	10.6%	0.0%	0.0%	0.0%
Lights	48	710	46	0	804	0	0	46	165	35	0	246	0	0	34	739	50	1	824	0	0	42	146	36	0	224	0	0	2098
% Lights	90.6%	95.6%	95.9%	0.0%	95.3%	0.0%	0.0%	97.9%	99.4%	94.6%	0.0%	98.0%	0.0%	0.0%	89.5%	95.1%	85.2%	100.0%	93.7%	0.0%	0.0%	95.5%	96.7%	90.0%	0.0%	95.3%	0.0%	0.0%	95.0%
Trucks	0	0	0	0	0	0	0	0	0	0	0	0	0	0	0	2	0	0	2	0	0	0	0	0	0	0	0	0	2
% Trucks	0.0%	0.0%	0.0%	0.0%	0.0%	0.0%	0.0%	0.0%	0.0%	0.0%	0.0%	0.0%	0.0%	0.0%	0.0%	0.3%	0.0%	0.0%	0.2%	0.0%	0.0%	0.0%	0.0%	0.0%	0.0%	0.0%	0.0%	0.0%	0.1%
Buses	5	33	2	0	40	0	0	1	1	2	0	4	0	0	4	35	8	0	47	0	0	2	5	4	0	11	0	0	102
% Buses	9.4%	4.4%	4.2%	0.0%	0.0%	0.0%	0.0%	0.0%	0.6%	5.4%	0.0%	0.0%	0.0%	0.0%	10.5%	4.5%	13.8%	0.0%	0.0%	0.0%	0.0%	4.5%	3.3%	10.0%	0.0%	0.0%	0.0%	0.0%	4.6%
Pedestrians	0	0	0	0	0	1	1	0	0	0	0	0	4	7	0	0	0	0	0	0	0	0	0	0	0	0	17	12	0
% Pedestrians	0.0%	0.0%	0.0%	0.0%	0.0%	100.0%	100.0%	0.0%	0.0%	0.0%	0.0%	0.0%	80.0%	100.0%	0.0%	0.0%	0.0%	0.0%	0.0%	0.0%	0.0%	0.0%	0.0%	0.0%	0.0%	0.0%	100.0%	100.0%	0.0%
Bicycles on Crosswalk	0	0	0	0	0	0	0	0	0	0	0	0	1	0	0	0	0	0	0	0	0	0	0	0	0	0	0	0	0
% Bicycles on Crosswalk	0.0%	0.0%	0.0%	0.0%	0.0%	0.0%	0.0%	0.0%	0.0%	0.0%	0.0%	0.0%	20.0%	0.0%	0.0%	0.0%	0.0%	0.0%	0.0%	0.0%	0.0%	0.0%	0.0%	0.0%	0.0%	0.0%	0.0%	0.0%	0.0%

### Turning Movement Data Plot

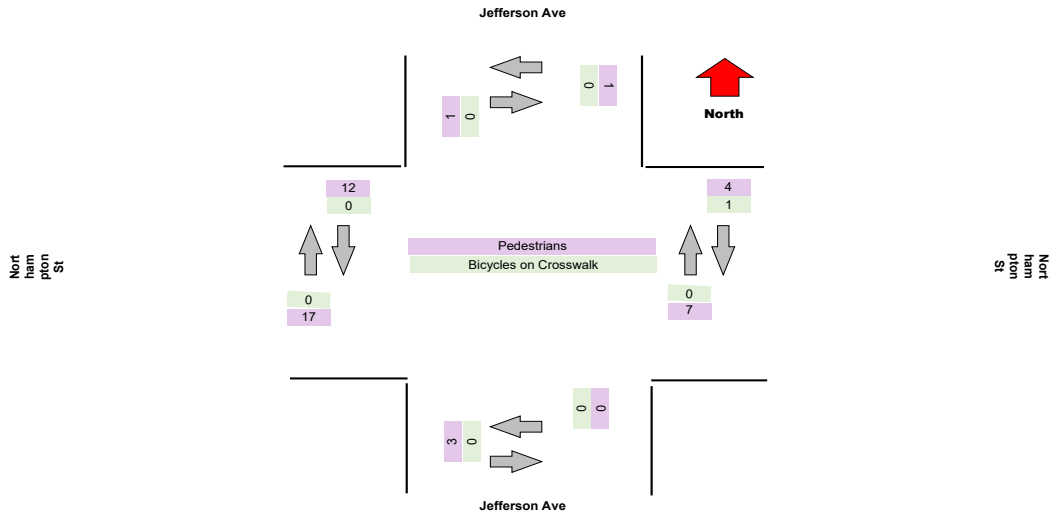
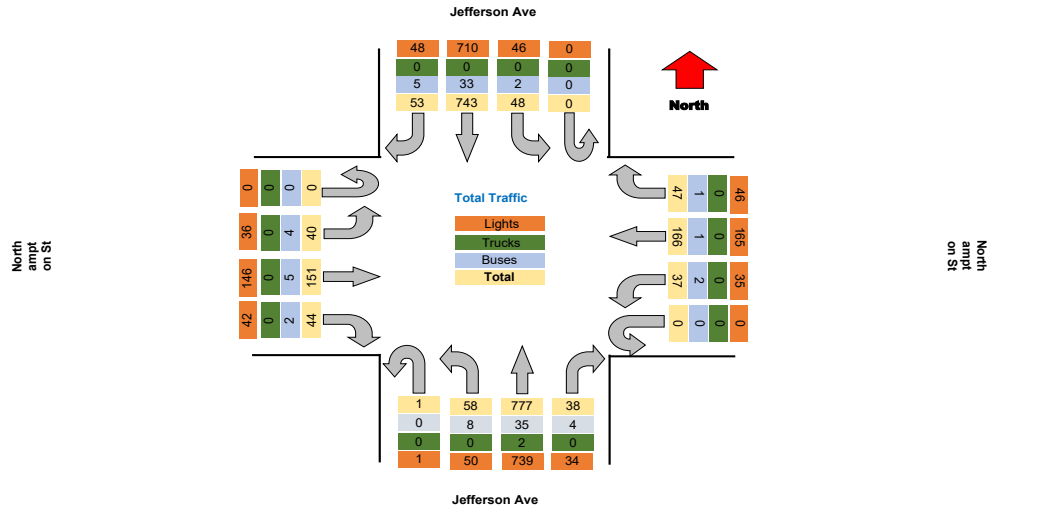

Project : VBH Malta NY  
Site : Site 4  
Location : 42.948550, -73.790036  
Survey Date : 2021-04-28, Wednesday

TSTData.com

**Turning Movement Peak Hour Data (AM)**

7:30:00 AM

Leg Direction	Jefferson Ave					Northampton St					Jefferson Ave					Northampton St					Total									
	Southbound					Westbound					Northbound					Eastbound														
Start Time	Right	Thru	Left	U-Turn	App Total	Peds CW	Peds CCW	Right	Thru	Left	U-Turn	App Total	Peds CW	Peds CCW	Right	Thru	Left	U-Turn	App Total	Peds CW	Peds CCW	Right	Thru	Left	U-Turn	App Total	Peds CW	Peds CCW	Total	
7:30:00 AM	2	36	2	0	40	0	1	0	9	2	0	12	0	0	1	32	3	0	36	0	0	2	6	1	0	9	0	0	97	
7:45:00 AM	6	43	2	0	51	0	0	1	15	0	0	16	1	0	2	49	7	0	59	0	0	0	13	2	0	15	2	0	141	
8:00:00 AM	3	44	2	0	49	0	0	1	17	5	0	23	0	0	2	41	4	0	47	0	2	3	10	1	0	14	0	0	133	
8:15:00 AM	3	37	2	0	42	0	0	3	19	3	0	25	1	1	2	43	9	0	56	0	0	7	11	3	0	21	1	2	144	
<b>Grand Total</b>	<b>14</b>	<b>160</b>	<b>8</b>	<b>0</b>	<b>182</b>	<b>0</b>	<b>1</b>	<b>5</b>	<b>50</b>	<b>10</b>	<b>0</b>	<b>75</b>	<b>2</b>	<b>1</b>	<b>7</b>	<b>155</b>	<b>23</b>	<b>0</b>	<b>198</b>	<b>0</b>	<b>2</b>	<b>12</b>	<b>40</b>	<b>7</b>	<b>0</b>	<b>59</b>	<b>3</b>	<b>2</b>	<b>515</b>	
% Approach	7.7%	87.9%	4.4%	0.0%	0.0%	0.0%	0.0%	6.6%	78.9%	13.2%	0.0%	0.0%	0.0%	0.0%	3.5%	83.3%	11.6%	0.0%	0.0%	0.0%	0.0%	20.3%	67.8%	11.9%	0.0%	0.0%	0.0%	0.0%	0.0%	
% Total	2.7%	31.1%	1.6%	0.0%	35.3%	0.0%	0.0%	1.0%	11.7%	1.9%	0.0%	14.8%	0.0%	0.0%	1.4%	32.0%	4.5%	0.0%	38.4%	0.0%	0.0%	2.3%	7.8%	1.4%	0.0%	11.5%	0.0%	0.0%	0.0%	
PHF	0.583	0.909	1.000	0.000	0.892	0.000	0.000	0.417	0.789	0.500	0.000	0.760	0.000	0.000	0.875	0.842	0.639	0.000	0.839	0.000	0.000	0.429	0.769	0.583	0.000	0.702	0.000	0.000	0.894	
Lights	12	151	7	0	170	0	0	5	59	9	0	73	0	0	6	150	20	0	176	0	0	12	38	5	0	55	0	0	474	
% Lights	85.7%	94.4%	87.5%	0.0%	93.4%	0.0%	0.0%	100.0%	98.3%	90.0%	0.0%	96.1%	0.0%	0.0%	85.7%	90.0%	87.0%	0.0%	88.9%	0.0%	0.0%	100.0%	95.0%	71.4%	0.0%	93.2%	0.0%	0.0%	92.0%	
Trucks	0	0	0	0	0	0	0	0	0	0	0	0	0	0	0	1	0	0	1	0	0	0	0	0	0	0	0	0	0	1
% Trucks	0.0%	0.0%	0.0%	0.0%	0.0%	0.0%	0.0%	0.0%	0.0%	0.0%	0.0%	0.0%	0.0%	0.0%	0.0%	0.6%	0.0%	0.0%	0.5%	0.0%	0.0%	0.0%	0.0%	0.0%	0.0%	0.0%	0.0%	0.0%	0.2%	
Buses	2	9	1	0	12	0	0	0	1	1	0	2	0	0	1	14	3	0	18	0	0	0	2	2	0	4	0	0	36	
% Buses	14.3%	5.6%	12.5%	0.0%	6.6%	0.0%	0.0%	0.0%	1.7%	10.0%	0.0%	2.7%	0.0%	0.0%	14.3%	8.5%	13.0%	0.0%	9.1%	0.0%	0.0%	0.0%	5.0%	28.6%	0.0%	6.7%	0.0%	0.0%	7.0%	
Pedestrians	0	0	0	0	0	0	1	0	0	0	0	0	2	1	0	0	0	0	0	0	2	0	0	0	0	0	3	2	0	
% Pedestrians	0.0%	0.0%	0.0%	0.0%	0.0%	100.0%	100.0%	0.0%	0.0%	0.0%	0.0%	0.0%	100.0%	100.0%	0.0%	0.0%	0.0%	0.0%	0.0%	0.0%	100.0%	100.0%	0.0%	0.0%	0.0%	0.0%	0.0%	100.0%	100.0%	0.0%
Bicycles on Crosswalk	0	0	0	0	0	0	0	0	0	0	0	0	0	0	0	0	0	0	0	0	0	0	0	0	0	0	0	0	0	
% Bicycles on Crosswalk	0.0%	0.0%	0.0%	0.0%	0.0%	0.0%	0.0%	0.0%	0.0%	0.0%	0.0%	0.0%	0.0%	0.0%	0.0%	0.0%	0.0%	0.0%	0.0%	0.0%	0.0%	0.0%	0.0%	0.0%	0.0%	0.0%	0.0%	0.0%	0.0%	

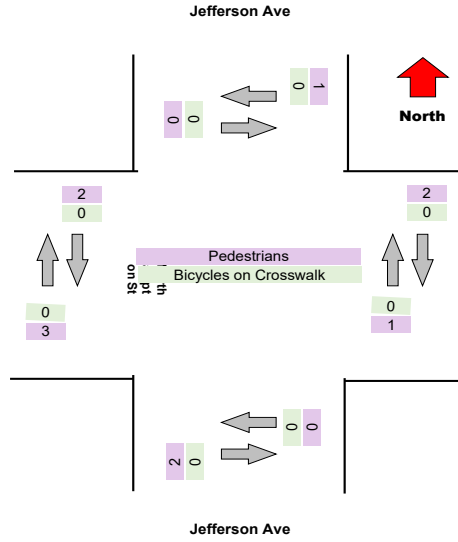
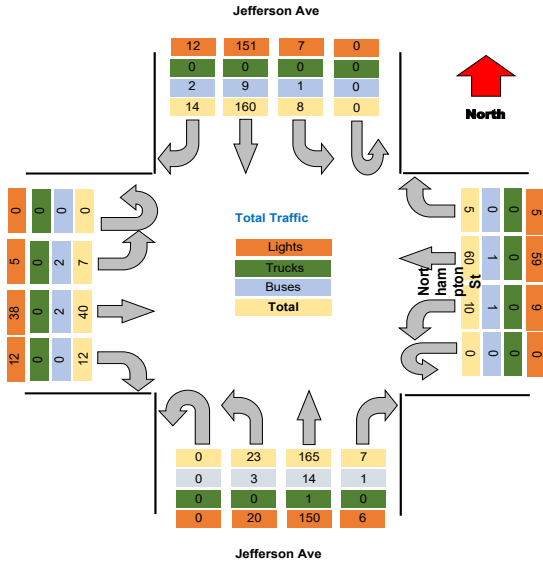

### Turning Movement Peak Hour Data (PM)

4:15:00 PM

Leg Direction	Jefferson Ave								Northampton St								Jefferson Ave								Northampton St								Total
	Southbound				Westbound				Northbound				Eastbound				Southbound				Westbound				Northbound				Eastbound				
	Right	Thru	Left	U-Turn	App Total	Peds CW	Peds CCW		Right	Thru	Left	U-Turn	App Total	Peds CW	Peds CCW		Right	Thru	Left	U-Turn	App Total	Peds CW	Peds CCW		Right	Thru	Left	U-Turn	App Total	Peds CW	Peds CCW		
4:15:00 PM	9	70	5	0	84	0	0		2	17	0	0	19	0	3		6	73	2	0	81	0	0		2	13	7	0	22	3	0		206
4:30:00 PM	4	65	0	0	69	1	0		4	13	4	0	21	1	1		0	66	3	0	69	0	0		5	19	4	0	28	0	0		187
4:45:00 PM	6	52	4	0	62	0	0		7	12	1	0	20	0	1		3	73	3	0	79	0	0		5	15	6	0	26	1	2		187
5:00:00 PM	6	71	4	0	81	0	0		4	10	2	0	16	0	0		5	64	4	1	74	0	0		4	8	6	0	18	0	1		189
<b>Grand Total</b>	<b>25</b>	<b>238</b>	<b>13</b>	<b>0</b>	<b>296</b>	<b>1</b>	<b>0</b>		<b>17</b>	<b>52</b>	<b>7</b>	<b>0</b>	<b>75</b>	<b>1</b>	<b>5</b>		<b>14</b>	<b>276</b>	<b>12</b>	<b>1</b>	<b>393</b>	<b>0</b>	<b>0</b>		<b>15</b>	<b>55</b>	<b>23</b>	<b>0</b>	<b>94</b>	<b>4</b>	<b>3</b>		<b>789</b>
% Approach	8.4%	87.2%	4.4%	0.0%	0.0%	0.0%	0.0%		22.4%	68.4%	9.2%	0.0%	0.0%	0.0%	0.0%		4.6%	91.1%	4.0%	0.3%	0.0%	0.0%	0.0%		17.0%	55.5%	24.5%	0.0%	0.0%	0.0%	0.0%		
% Total	3.3%	33.6%	1.7%	0.0%	38.5%	0.0%	0.0%		2.2%	6.8%	0.9%	0.0%	9.9%	0.0%	0.0%		1.8%	35.9%	1.6%	0.1%	39.4%	0.0%	0.0%		2.1%	7.2%	3.0%	0.0%	12.2%	0.0%	0.0%		
PHF	0.694	0.908	0.650	0.000	0.881	0.000	0.000		0.607	0.765	0.438	0.000	0.905	0.000	0.000		0.583	0.945	0.750	0.250	0.835	0.000	0.000		0.800	0.724	0.821	0.000	0.839	0.000	0.000		0.933
Lights	25	248	12	0	285	0	0		17	52	7	0	76	0	0		13	266	11	1	291	0	0		14	53	22	0	89	0	0		741
% Lights	100.0%	96.1%	92.3%	0.0%	96.3%	0.0%	0.0%		100.0%	100.0%	100.0%	0.0%	100.0%	0.0%	0.0%		92.9%	96.4%	91.7%	100.0%	96.0%	0.0%	0.0%		87.5%	96.4%	95.7%	0.0%	94.7%	0.0%	0.0%		96.4%
Trucks	0	0	0	0	0	0	0		0	0	0	0	0	0	0		0	0	0	0	0	0	0		0	0	0	0	0	0	0		0
% Trucks	0.0%	0.0%	0.0%	0.0%	0.0%	0.0%	0.0%		0.0%	0.0%	0.0%	0.0%	0.0%	0.0%	0.0%		0.0%	0.0%	0.0%	0.0%	0.0%	0.0%	0.0%		0.0%	0.0%	0.0%	0.0%	0.0%	0.0%	0.0%		0.0%
Buses	0	10	1	0	11	0	0		0	0	0	0	0	0	0		1	9	1	0	11	0	0		2	2	1	0	5	0	0		27
% Buses	0.0%	3.9%	7.7%	0.0%	0.0%	0.0%	0.0%		0.0%	0.0%	0.0%	0.0%	0.0%	0.0%	0.0%		7.1%	3.3%	8.3%	0.0%	0.0%	0.0%	0.0%		12.5%	3.8%	4.3%	0.0%	0.0%	0.0%	0.0%		3.5%
Pedestrians	0	0	0	0	0	1	0		0	0	0	0	1	5	0		0	0	0	0	0	0	0		0	0	0	0	0	4	3		0
% Pedestrians	0.0%	0.0%	0.0%	0.0%	0.0%	100.0%	0.0%		0.0%	0.0%	0.0%	0.0%	0.0%	100.0%	100.0%		0.0%	0.0%	0.0%	0.0%	0.0%	0.0%	0.0%		0.0%	0.0%	0.0%	0.0%	0.0%	100.0%	100.0%		0.0%
Bicycles on Crosswalk	0	0	0	0	0	0	0		0	0	0	0	0	0	0		0	0	0	0	0	0	0		0	0	0	0	0	0	0		0
% Bicycles on Crosswalk	0.0%	0.0%	0.0%	0.0%	0.0%	0.0%	0.0%		0.0%	0.0%	0.0%	0.0%	0.0%	0.0%	0.0%		0.0%	0.0%	0.0%	0.0%	0.0%	0.0%	0.0%		0.0%	0.0%	0.0%	0.0%	0.0%	0.0%	0.0%		0.0%

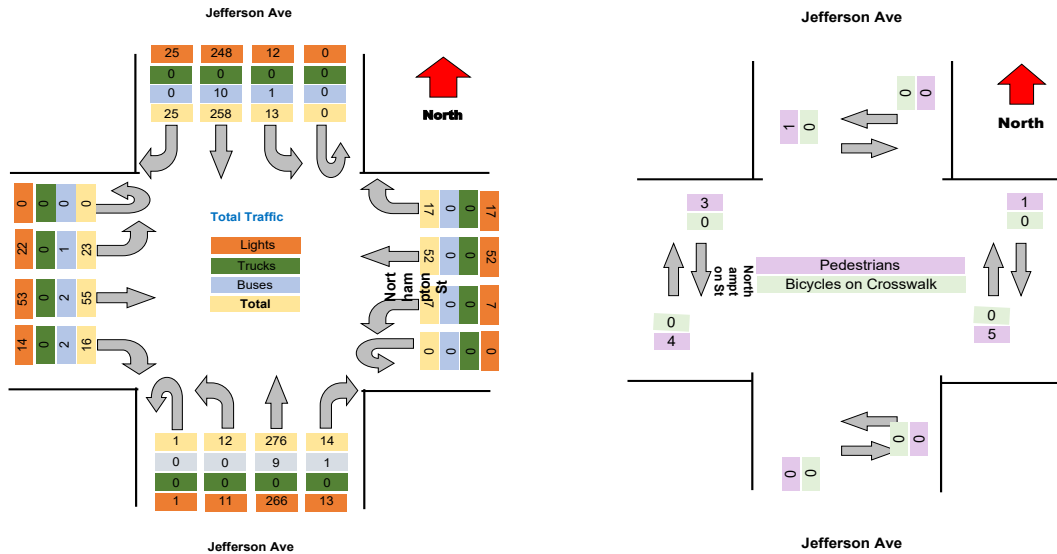

Project : VBH Malta NY  
 Site : Site 4  
 Location : 42.948550, -73.790036

TSTData.com

Survey Date : 2021-04-28, Wednesday

Project	LaBella
Project Code	LaBella
Site Name	36
Legs and Movements	All Processed Legs & Move
Bin Size	15 minutes
Survey Date	2021-11-02, Tuesday
Location	36
Latitude and Longitude	42.903857, -78.853998

	Start	End	PHF
Forced Peak AM	2021/11/02 07:30:00	2021/11/02 08:30:00	0.99
Forced Peak PM	2021/11/02 16:30:00	2021/11/02 17:30:00	0.92
AM Peak	2021/11/02 07:30:00	2021/11/02 08:30:00	0.99
PM Peak	2021/11/02 16:15:00	2021/11/02 17:15:00	0.9

### Turning Movement Data

Leg Direction	Jefferson Ave										Best St										Jefferson Ave										Best St										Total
	Southbound					Westbound					Northbound					Eastbound					Southbound					Westbound					Northbound					Eastbound					
Start Time	Right	Thru	Left	U-Turn	App Total	Peds CV	Peds CCV	Right	Thru	Left	U-Turn	App Total	Peds CV	Peds CCV	Right	Thru	Left	U-Turn	App Total	Peds CV	Peds CCV	Right	Thru	Left	U-Turn	App Total	Peds CV	Peds CCV	Right	Thru	Left	U-Turn	App Total	Peds CV	Peds CCV	Total					
6:30:00 AM	1	9	3	0	13	0	0	7	56	9	0	72	0	0	7	11	0	0	18	1	0	1	22	0	0	23	0	0	1	22	0	0	23	0	0	126					
6:45:00 AM	2	18	5	0	25	0	0	6	82	9	0	97	0	0	2	17	2	0	21	0	1	1	28	4	0	33	0	1	1	28	4	0	33	0	1	178					
Hourly Total	3	27	8	0	38	0	0	13	138	18	0	169	0	0	9	28	2	0	39	1	1	2	50	4	0	56	0	1	2	50	4	0	56	0	1	302					
7:00:00 AM	0	13	1	0	14	0	0	8	49	5	0	60	0	0	7	14	0	0	21	1	0	2	32	18	0	52	0	0	2	32	18	0	52	0	0	147					
7:15:00 AM	1	20	7	0	28	0	0	8	49	7	0	64	0	1	3	17	1	0	22	0	0	1	32	2	0	35	1	0	1	32	2	0	35	1	0	149					
7:30:00 AM	5	14	7	0	26	0	0	11	65	13	0	89	0	0	11	32	0	0	43	0	0	3	57	1	0	61	0	0	3	57	1	0	61	0	0	219					
7:45:00 AM	2	28	7	0	37	0	0	5	82	5	0	102	0	1	4	19	5	0	29	0	0	4	49	1	0	54	0	0	4	49	1	0	54	0	0	222					
Hourly Total	8	75	22	0	105	0	0	30	255	30	0	315	0	2	25	82	6	0	115	1	0	10	170	22	0	202	1	0	10	170	22	0	202	1	0	737					
8:00:00 AM	3	29	4	0	36	0	0	17	66	5	0	88	1	0	5	30	8	0	44	0	0	7	46	1	0	54	0	0	7	46	1	0	54	0	0	212					
8:15:00 AM	4	29	10	0	43	0	0	15	73	8	0	96	0	0	5	21	4	0	30	0	0	2	44	3	0	49	0	0	2	44	3	0	49	0	0	218					
Hourly Total	7	58	14	0	79	0	0	32	139	13	0	184	1	0	10	51	12	0	74	0	0	9	90	4	0	103	0	0	9	90	4	0	103	0	0	440					
4:00:00 PM	5	50	19	0	74	1	1	12	72	8	0	92	0	0	21	48	4	0	73	0	0	5	99	7	0	111	0	2	5	99	7	0	111	0	2	350					
4:15:00 PM	6	46	17	0	69	0	0	10	75	4	0	89	0	1	19	38	6	0	63	0	1	12	84	5	0	101	0	0	12	84	5	0	101	0	0	322					
4:30:00 PM	7	55	13	0	75	1	0	25	48	4	0	77	0	0	22	58	3	0	83	0	1	14	94	1	0	109	0	1	14	94	1	0	109	0	1	344					
4:45:00 PM	10	45	9	0	64	0	0	16	55	7	0	78	0	2	13	60	1	0	74	0	1	2	86	6	0	94	0	0	2	86	6	0	94	0	0	310					
Hourly Total	28	196	58	0	282	2	1	63	250	23	0	338	0	3	75	204	14	0	293	0	2	33	363	19	0	415	0	3	33	363	19	0	415	0	3	1326					
5:00:00 PM	6	44	10	0	60	0	1	14	74	10	0	98	0	0	16	68	10	0	94	1	0	10	111	1	0	122	0	0	10	111	1	0	122	0	0	374					
5:15:00 PM	5	59	22	0	86	0	0	15	75	6	0	96	5	0	20	41	9	0	70	0	0	6	90	3	0	99	0	0	6	90	3	0	99	0	0	351					
5:30:00 PM	4	36	20	0	60	1	0	12	65	4	0	81	0	0	18	52	4	0	74	1	1	6	70	3	0	79	0	0	6	70	3	0	79	0	0	294					
5:45:00 PM	7	45	8	0	60	1	0	18	63	4	0	85	0	2	8	46	4	0	58	1	0	6	76	2	0	84	2	0	6	76	2	0	84	2	0	287					
Hourly Total	22	184	60	0	266	2	1	59	277	24	0	360	5	2	62	207	27	0	296	3	4	28	347	9	0	384	2	0	28	347	9	0	384	2	0	1306					
Grand Total	68	540	162	0	770	4	2	197	1059	108	0	1364	6	7	181	572	61	0	817	5	7	82	1020	58	0	1160	3	4	82	1020	58	0	1160	3	4	4111					
% Approach	8.6%	70.1%	21.0%	0.0%	0.0%	0.0%	0.0%	14.4%	77.6%	7.9%	0.0%	0.0%	0.0%	0.0%	22.2%	70.0%	7.5%	0.0%	0.0%	0.0%	0.0%	7.1%	87.9%	5.0%	0.0%	0.0%	0.0%	0.0%	0.0%	0.0%	0.0%	0.0%	0.0%	0.0%	0.0%	0.0%					
% Total	1.7%	13.1%	3.9%	0.0%	18.7%	0.0%	0.0%	4.8%	25.8%	2.6%	0.0%	33.2%	0.0%	0.0%	4.4%	13.9%	1.5%	0.0%	19.9%	0.0%	0.0%	2.0%	24.8%	1.4%	0.0%	28.2%	0.0%	0.0%	2.0%	24.8%	1.4%	0.0%	28.2%	0.0%	0.0%	0.0%					
Lights	66	529	160	0	755	0	0	196	1043	106	0	1345	0	0	181	556	60	0	797	0	0	82	1007	58	0	1147	0	0	82	1007	58	0	1147	0	0	4044					
% Lights	97.1%	98.0%	98.9%	0.0%	98.1%	0.0%	0.0%	99.5%	98.9%	98.1%	0.0%	98.6%	0.0%	0.0%	100.0%	97.2%	98.4%	0.0%	97.6%	0.0%	0.0%	100.0%	98.7%	100.0%	0.0%	98.9%	0.0%	0.0%	100.0%	98.7%	100.0%	0.0%	98.9%	0.0%	0.0%	98.4%					
Trucks	0	1	0	0	1	0	0	1	1	0	0	2	0	0	0	0	0	0	0	0	0	0	0	0	0	0	0	0	0	0	0	0	0	0	0	3					
% Trucks	0.0%	0.2%	0.0%	0.0%	0.1%	0.0%	0.0%	0.5%	0.1%	0.0%	0.0%	0.1%	0.0%	0.0%	0.0%	0.0%	0.0%	0.0%	0.0%	0.0%	0.0%	0.0%	0.0%	0.0%	0.0%	0.0%	0.0%	0.0%	0.0%	0.0%	0.0%	0.0%	0.0%	0.0%	0.0%	0.1%					
Buses	2	9	2	0	13	0	0	0	14	2	0	16	0	0	0	15	1	0	16	0	0	0	12	0	0	12	0	0	0	12	0	0	12	0	0	57					
% Buses	2.9%	1.7%	1.2%	0.0%	0.0%	0.0%	0.0%	0.0%	1.3%	1.9%	0.0%	0.0%	0.0%	0.0%	0.0%	2.6%	1.6%	0.0%	0.0%	0.0%	0.0%	0.0%	1.2%	0.0%	0.0%	0.0%	0.0%	0.0%	0.0%	1.2%	0.0%	0.0%	0.0%	0.0%	0.0%	1.4%					
Pedestrians	0	0	0	0	0	4	2	0	0	0	0	0	6	7	0	0	0	0	0	5	7	0	0	0	0	0	1	3	0	0	0	0	0	1	3	0					
% Pedestrians	0.0%	0.0%	0.0%	0.0%	0.0%	100.0%	100.0%	0.0%	0.0%	0.0%	0.0%	0.0%	100.0%	100.0%	0.0%	0.0%	0.0%	0.0%	0.0%	100.0%	100.0%	0.0%	0.0%	0.0%	0.0%	0.0%	33.3%	75.0%	0.0%	33.3%	75.0%	0.0%	33.3%	75.0%	0.0%						
Bicycles on Crosswalk	0	0	0	0	0	0	0	0	0	0	0	0	0	0	0	0	0	0	0	0	0	0	0	0	0	0	2	1	0	0	0	0	0	2	1	0					
% Bicycles on Crosswalk	0.0%	0.0%	0.0%	0.0%	0.0%	0.0%	0.0%	0.0%	0.0%	0.0%	0.0%	0.0%	0.0%	0.0%	0.0%	0.0%	0.0%	0.0%	0.0%	0.0%	0.0%	0.0%	0.0%	0.0%	0.0%	0.0%	66.7%	25.0%	0.0%	66.7%	25.0%	0.0%	66.7%	25.0%	0.0%						

Project : VBH Malta NY  
 Site : Site 4  
 Location : 42.948550, -73.790036  
 Survey Date : 2021-04-28, Wednesday

### Turning Movement Data Plot

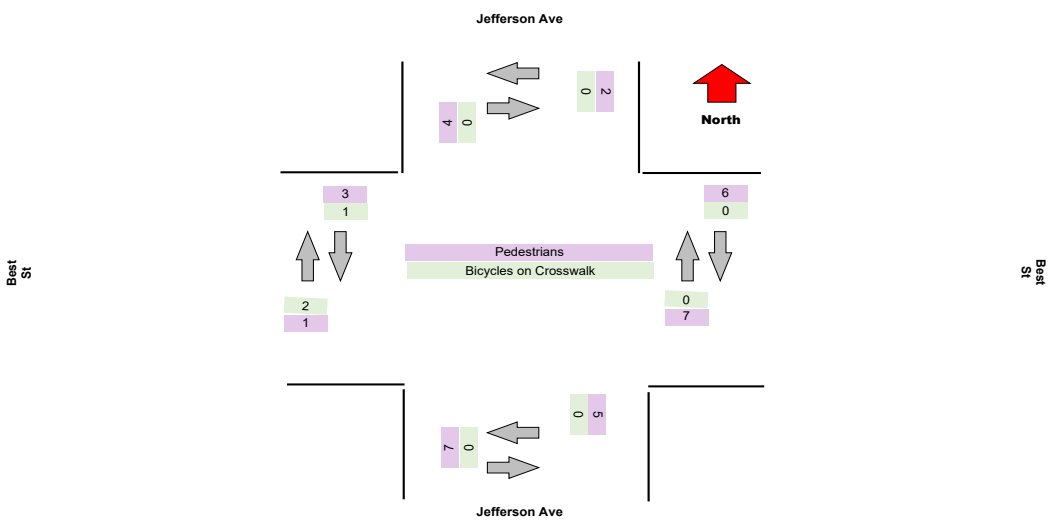
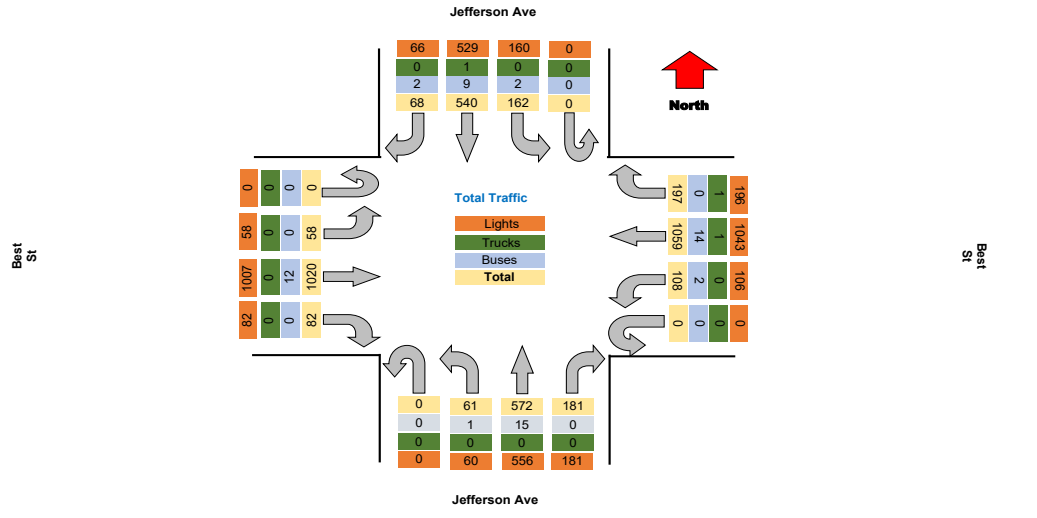



Project : VBH Malta NY  
Site : Site 4  
Location : 42.948550, -73.790036

TSTData.com

Survey Date : 2021-04-28, Wednesday

### Turning Movement Peak Hour Data (AM)

7:30:00 AM

Leg Direction	Jefferson Ave				Best St				Jefferson Ave				Best St				Total					
	Southbound		Northbound		Westbound		Eastbound		Northbound		Eastbound		Westbound		Eastbound							
Start Time	Right	Thru	Left	U-Turn	App Total	Peds CW	Peds CCW	Right	Thru	Left	U-Turn	App Total	Peds CW	Peds CCW	Right	Thru	Left	U-Turn	App Total	Peds CW	Peds CCW	
7:30:00 AM	5	14	7	0	26	0	0	11	65	13	0	89	0	0	11	32	0	0	43	0	0	
7:45:00 AM	2	28	7	0	37	0	0	5	92	5	0	102	0	1	4	19	5	0	29	0	0	
8:00:00 AM	3	29	4	0	36	0	0	17	66	5	0	88	1	0	5	30	8	0	44	0	0	
8:15:00 AM	4	29	10	0	43	0	0	15	73	8	0	96	0	0	5	21	4	0	30	0	0	
<b>Grand Total</b>	<b>14</b>	<b>109</b>	<b>28</b>	<b>0</b>	<b>142</b>	<b>0</b>	<b>0</b>	<b>48</b>	<b>296</b>	<b>31</b>	<b>0</b>	<b>375</b>	<b>1</b>	<b>1</b>	<b>25</b>	<b>102</b>	<b>17</b>	<b>0</b>	<b>146</b>	<b>0</b>	<b>0</b>	
% Approach	9.9%	70.4%	19.7%	0.0%	0.0%	0.0%	0.0%	12.8%	78.9%	8.3%	0.0%	0.0%	0.0%	0.0%	17.1%	69.9%	11.6%	0.0%	0.0%	0.0%	0.0%	0.0%
% Total	1.6%	11.4%	3.2%	0.0%	16.1%	0.0%	0.0%	5.4%	33.6%	3.5%	0.0%	42.6%	0.0%	0.0%	2.8%	11.6%	1.9%	0.0%	16.6%	0.0%	0.0%	
PHF	0.700	0.862	0.700	0.000	0.826	0.000	0.000	0.706	0.804	0.596	0.000	0.919	0.000	0.000	0.568	0.797	0.531	0.000	0.830	0.000	0.000	
Lights	13	98	27	0	138	0	0	48	292	29	0	369	0	0	25	99	17	0	141	0	0	
% Lights	92.9%	98.0%	96.4%	0.0%	97.2%	0.0%	0.0%	100.0%	98.6%	93.5%	0.0%	98.4%	0.0%	0.0%	100.0%	97.1%	100.0%	0.0%	96.6%	0.0%	0.0%	
Trucks	0	0	0	0	0	0	0	0	0	0	0	0	0	0	0	0	0	0	0	0	0	0
% Trucks	0.0%	0.0%	0.0%	0.0%	0.0%	0.0%	0.0%	0.0%	0.0%	0.0%	0.0%	0.0%	0.0%	0.0%	0.0%	0.0%	0.0%	0.0%	0.0%	0.0%	0.0%	0.0%
Buses	1	2	1	0	4	0	0	0	4	2	0	6	0	0	0	3	0	0	3	0	0	
% Buses	7.1%	2.0%	3.6%	0.0%	0.0%	0.0%	0.0%	0.0%	1.4%	6.5%	0.0%	0.0%	0.0%	0.0%	0.0%	2.9%	0.0%	0.0%	0.0%	0.0%	0.0%	
Pedestrians	0	0	0	0	0	0	0	0	0	0	0	1	1	0	0	0	0	0	0	0	0	
% Pedestrians	0.0%	0.0%	0.0%	0.0%	0.0%	0.0%	0.0%	0.0%	0.0%	0.0%	0.0%	0.0%	100.0%	100.0%	0.0%	0.0%	0.0%	0.0%	0.0%	0.0%	0.0%	
Bicycles on Crosswalk	0	0	0	0	0	0	0	0	0	0	0	0	0	0	0	0	0	0	0	0	0	
% Bicycles on Crosswalk	0.0%	0.0%	0.0%	0.0%	0.0%	0.0%	0.0%	0.0%	0.0%	0.0%	0.0%	0.0%	0.0%	0.0%	0.0%	0.0%	0.0%	0.0%	0.0%	0.0%	0.0%	

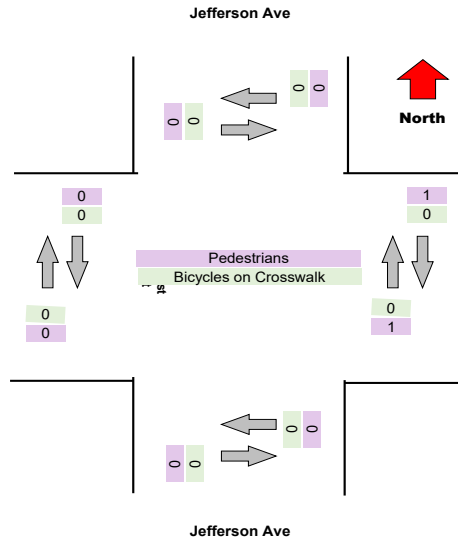
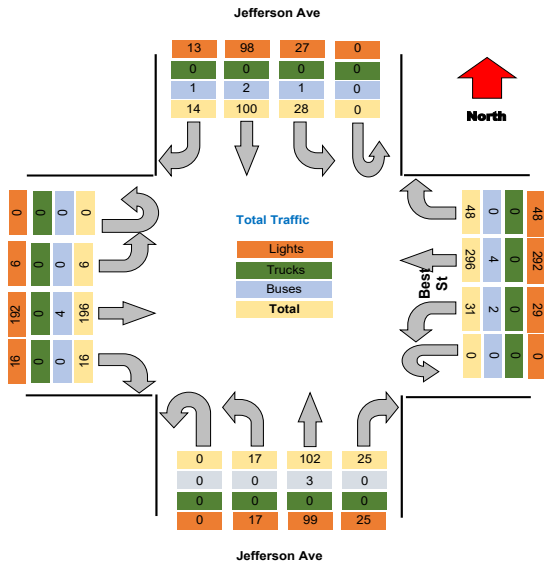

**Turning Movement Peak Hour Data (PM)**

4:15:00 PM

Leg Direction	Jefferson Ave										Best St				Jefferson Ave										Best St				Total
	Southbound					Westbound					Northbound					Eastbound													
	Right	Thru	Left	U-Turn	App Total	Right	Thru	Left	U-Turn	App Total	Right	Thru	Left	U-Turn	App Total	Right	Thru	Left	U-Turn	App Total									
4:15:00 PM	6	46	17	0	69	10	75	4	0	89	19	38	6	0	63	12	84	5	0	101									
4:30:00 PM	7	55	13	0	75	25	48	4	0	77	22	58	3	0	83	14	94	1	0	109									
4:45:00 PM	10	45	9	0	64	16	55	7	0	78	13	60	1	0	74	2	86	6	0	94									
5:00:00 PM	6	44	10	0	60	14	74	10	0	98	16	56	10	0	82	10	111	1	0	122									
<b>Grand Total</b>	<b>29</b>	<b>190</b>	<b>49</b>	<b>0</b>	<b>268</b>	<b>65</b>	<b>252</b>	<b>25</b>	<b>0</b>	<b>342</b>	<b>70</b>	<b>224</b>	<b>20</b>	<b>0</b>	<b>314</b>	<b>38</b>	<b>375</b>	<b>13</b>	<b>0</b>	<b>426</b>									
% Approach	10.8%	70.9%	18.3%	0.0%	0.0%	19.0%	73.7%	7.3%	0.0%	0.0%	22.3%	71.3%	6.4%	0.0%	0.0%	8.9%	86.0%	3.1%	0.0%	0.0%									
% Total	2.1%	14.1%	3.6%	0.0%	19.9%	4.8%	18.7%	1.9%	0.0%	25.3%	5.2%	16.6%	1.5%	0.0%	23.3%	2.8%	27.8%	1.0%	0.0%	31.6%									
PHF	0.725	0.864	0.721	0.000	0.893	0.650	0.840	0.625	0.000	0.872	0.795	0.824	0.500	0.000	0.835	0.679	0.845	0.542	0.000	0.873									
Lights	28	185	49	0	262	65	248	25	0	338	70	218	19	0	307	38	371	13	0	422									
% Lights	96.6%	97.4%	100.0%	0.0%	97.8%	100.0%	98.4%	100.0%	0.0%	98.8%	100.0%	97.3%	95.0%	0.0%	97.8%	100.0%	98.9%	100.0%	0.0%	99.1%									
Trucks	0	1	0	0	1	0	0	0	0	0	0	0	0	0	0	0	0	0	0	0									
% Trucks	0.0%	0.5%	0.0%	0.0%	0.4%	0.0%	0.0%	0.0%	0.0%	0.0%	0.0%	0.0%	0.0%	0.0%	0.0%	0.0%	0.0%	0.0%	0.0%	0.0%									
Buses	1	3	0	0	4	0	3	0	0	3	0	5	1	0	6	0	3	0	0	3									
% Buses	3.4%	1.6%	0.0%	0.0%	0.0%	0.0%	1.2%	0.0%	0.0%	0.0%	0.0%	2.2%	5.0%	0.0%	0.0%	0.0%	0.8%	0.0%	0.0%	0.0%									
Pedestrians	0	0	0	0	0	0	0	0	0	0	0	0	0	0	0	0	0	0	0	0									
% Pedestrians	0.0%	0.0%	0.0%	0.0%	0.0%	0.0%	0.0%	0.0%	0.0%	0.0%	0.0%	0.0%	0.0%	0.0%	0.0%	0.0%	0.0%	0.0%	0.0%	0.0%									
Bicycles on Crosswalk	0	0	0	0	0	0	0	0	0	0	0	0	0	0	0	0	0	0	0	0									
% Bicycles on Crosswalk	0.0%	0.0%	0.0%	0.0%	0.0%	0.0%	0.0%	0.0%	0.0%	0.0%	0.0%	0.0%	0.0%	0.0%	0.0%	0.0%	0.0%	0.0%	0.0%	0.0%									

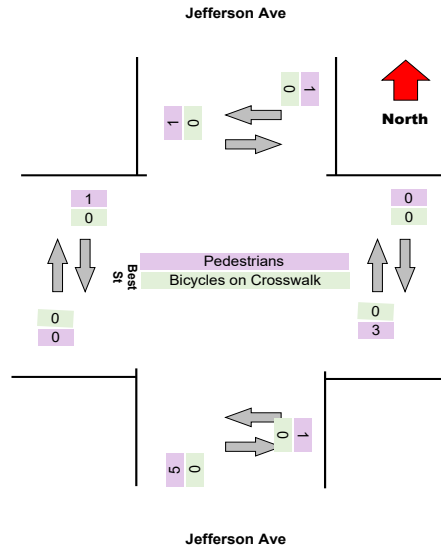
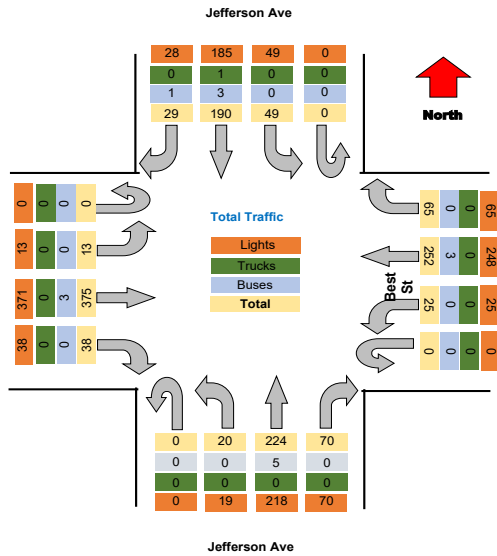

Project : VBH Malta NY  
Site : Site 4  
Location : 42.948550, -73.790036

TSTData.com

Survey Date : 2021-04-28, Wednesday

Project	LaBella
Project Code	LaBella
Site Name	36
Legs and Movements	All Processed Legs & Move
Bin Size	15 minutes
Survey Date	2021-11-03, Wednesday
Location	36
Latitude and Longitude	42.903857, -78.853998

	Start	End	PHF
Forced Peak AM	2021/11/03 07:30:00	2021/11/03 08:30:00	0.87
Forced Peak PM	2021/11/03 16:30:00	2021/11/03 17:30:00	0.89
AM Peak	2021/11/03 07:30:00	2021/11/03 08:30:00	0.89
PM Peak	2021/11/03 16:15:00	2021/11/03 17:15:00	0.91

### Turning Movement Data

Leg Direction	Jefferson Ave										Best St				Jefferson Ave										Best St				Total							
	Southbound					Westbound					Westbound		Northbound		Northbound					Eastbound																
	Right	Thru	Left	U-Turn	App Total	Perfs CW	Perfs CCW	Right	Thru	Left	U-Turn	App Total	Perfs CW	Perfs CCW	Right	Thru	Left	U-Turn	App Total	Perfs CW	Perfs CCW	Right	Thru	Left	U-Turn	App Total	Perfs CW	Perfs CCW								
6:30:00 AM	2	8	3	0	13	0	1	6	67	8	0	82	0	0	2	15	1	0	18	0	0	0	25	0	0	25	0	0	0	0	0	0	0	0	0	138
6:45:00 AM	1	17	6	0	24	0	0	9	93	11	0	113	3	0	4	20	3	0	30	0	0	0	27	3	0	30	2	1	0	0	0	0	0	0	0	197
Hourly Total	3	25	9	0	37	0	1	15	160	19	0	195	3	0	6	35	4	0	49	0	0	0	52	3	0	55	2	1	0	0	0	0	0	0	0	335
7:00:00 AM	2	25	9	0	37	2	0	8	50	11	0	67	0	2	7	27	4	0	40	0	0	4	51	17	0	72	0	0	0	0	0	0	0	0	0	211
7:15:00 AM	0	25	11	0	36	0	2	13	77	14	0	106	0	0	7	27	2	0	36	0	0	8	40	5	0	53	2	1	0	0	0	0	0	0	0	231
7:30:00 AM	5	30	12	0	47	0	0	7	81	7	0	95	0	1	9	32	2	0	44	1	0	7	81	4	0	92	0	0	0	0	0	0	0	0	0	278
7:45:00 AM	10	49	9	0	68	0	0	10	106	19	0	135	0	0	12	36	8	0	56	0	0	9	96	3	0	108	0	0	0	0	0	0	0	0	0	367
Hourly Total	17	129	37	0	183	2	2	36	314	51	0	403	0	3	35	122	16	0	176	1	0	28	268	29	0	325	2	1	0	0	0	0	0	0	0	1087
8:00:00 AM	5	51	12	0	68	0	0	15	105	10	0	130	0	0	15	35	4	0	55	1	0	16	92	7	0	115	0	0	0	0	0	0	0	0	0	368
8:15:00 AM	2	35	6	0	43	0	2	19	74	5	0	100	0	0	6	37	5	0	48	1	0	5	60	5	0	70	0	1	0	0	0	0	0	0	0	261
Hourly Total	7	86	18	0	111	0	2	34	179	15	0	230	0	1	21	72	9	0	103	2	0	21	152	12	0	185	0	1	0	0	0	0	0	0	0	629
4:00:00 PM	6	43	20	0	69	0	0	21	62	8	0	91	0	0	20	66	11	0	97	0	2	11	99	3	0	113	0	1	0	0	0	0	0	0	0	370
4:15:00 PM	4	52	22	0	78	0	0	19	82	10	0	111	1	0	17	59	6	0	82	0	0	9	100	3	0	112	0	0	0	0	0	0	0	0	0	383
4:30:00 PM	9	63	20	0	92	0	0	7	65	10	0	82	0	0	22	48	5	0	75	0	1	8	109	2	0	119	0	0	0	0	0	0	0	0	0	366
4:45:00 PM	3	44	10	0	57	0	0	13	65	4	0	82	0	0	18	61	3	0	82	0	1	12	86	5	0	103	0	0	0	0	0	0	0	0	0	324
Hourly Total	22	202	72	0	296	0	0	60	274	32	0	366	1	0	77	234	25	0	336	0	4	40	394	13	0	447	0	1	0	0	0	0	0	0	0	1445
5:00:00 PM	6	63	14	0	83	0	1	19	74	11	0	104	1	0	17	73	10	0	100	2	2	10	105	3	0	118	0	0	0	0	0	0	0	0	0	405
5:15:00 PM	3	51	20	0	74	0	0	9	65	5	0	79	0	0	11	58	6	0	75	0	1	6	95	8	0	109	0	1	0	0	0	0	0	0	0	337
5:30:00 PM	8	48	14	0	70	0	0	22	65	6	0	93	0	0	21	56	5	0	82	0	0	3	81	5	0	89	0	0	0	0	0	0	0	0	0	334
5:45:00 PM	5	49	9	0	63	1	0	16	62	9	0	87	0	0	13	45	5	0	63	0	1	10	69	7	0	86	0	0	0	0	0	0	0	0	0	299
Hourly Total	22	211	57	0	290	1	1	66	266	31	0	363	1	0	62	232	26	0	320	2	4	29	350	23	0	402	0	1	0	0	0	0	0	0	0	1375
Grand Total	71	653	193	0	917	3	6	211	1193	148	0	1557	5	4	201	695	80	0	983	5	8	118	1216	80	0	1414	4	5	0	0	0	0	0	0	0	4871
% Approach	7.7%	71.2%	21.0%	0.0%	0.0%	0.0%	0.0%	13.6%	76.6%	9.5%	0.0%	0.0%	0.0%	0.0%	20.4%	70.7%	8.1%	0.0%	0.0%	0.0%	0.0%	8.3%	86.0%	5.7%	0.0%	0.0%	0.0%	0.0%	0.0%	0.0%	0.0%	0.0%	0.0%	0.0%		
% Total	1.5%	13.4%	4.0%	0.0%	18.8%	0.0%	0.0%	4.3%	24.5%	3.0%	0.0%	32.0%	0.0%	0.0%	4.1%	14.3%	1.6%	0.0%	20.2%	0.0%	0.0%	2.4%	25.0%	1.6%	0.0%	29.0%	0.0%	0.0%	0.0%	0.0%	0.0%	0.0%	0.0%	0.0%	0.0%	0.0%
Lights	67	610	185	0	862	0	0	201	1152	139	0	1492	0	0	192	657	73	0	922	0	0	109	1185	78	0	1372	0	0	0	0	0	0	0	0	0	4648
% Lights	94.4%	93.4%	95.9%	0.0%	94.0%	0.0%	0.0%	95.3%	96.6%	93.9%	0.0%	95.8%	0.0%	0.0%	95.5%	94.5%	91.3%	0.0%	93.8%	0.0%	0.0%	92.4%	97.5%	97.5%	0.0%	97.8%	0.0%	0.0%	0.0%	0.0%	0.0%	0.0%	0.0%	0.0%	0.0%	95.4%
Trucks	0	1	0	0	1	0	0	0	0	0	0	0	0	0	1	0	0	0	1	0	0	0	0	0	0	0	0	0	0	0	0	0	0	0	0	2
% Trucks	0.0%	0.2%	0.0%	0.0%	0.1%	0.0%	0.0%	0.0%	0.0%	0.0%	0.0%	0.0%	0.0%	0.0%	0.5%	0.0%	0.0%	0.0%	0.1%	0.0%	0.0%	0.0%	0.0%	0.0%	0.0%	0.0%	0.0%	0.0%	0.0%	0.0%	0.0%	0.0%	0.0%	0.0%	0.0%	0.0%
Buses	4	42	8	0	54	0	0	10	41	9	0	60	0	0	8	38	7	0	53	0	0	9	31	2	0	42	0	0	0	0	0	0	0	0	0	209
% Buses	5.6%	6.4%	4.1%	0.0%	0.0%	0.0%	0.0%	0.0%	3.4%	6.1%	0.0%	0.0%	0.0%	0.0%	4.0%	5.5%	8.8%	0.0%	0.0%	0.0%	0.0%	7.6%	2.5%	2.5%	0.0%	0.0%	0.0%	0.0%	0.0%	0.0%	0.0%	0.0%	0.0%	0.0%	0.0%	4.3%
Pedestrians	0	0	0	0	0	3	5	0	0	0	0	0	5	4	0	0	0	0	0	5	8	0	0	0	0	0	4	4	0	0	0	0	0	0	0	0
% Pedestrians	0.0%	0.0%	0.0%	0.0%	0.0%	100.0%	83.3%	0.0%	0.0%	0.0%	0.0%	0.0%	100.0%	100.0%	0.0%	0.0%	0.0%	0.0%	0.0%	100.0%	100.0%	0.0%	0.0%	0.0%	0.0%	0.0%	100.0%	80.0%	0.0%	0.0%	0.0%	0.0%	0.0%	0.0%	0.0%	0.0%
Bicycles on Crosswalk	0	0	0	0	0	0	1	0	0	0	0	0	0	0	0	0	0	0	0	0	0	0	0	0	0	0	0	0	0	0	0	0	0	0	0	1
% Bicycles on Crosswalk	0.0%	0.0%	0.0%	0.0%	0.0%	0.0%	16.7%	0.0%	0.0%	0.0%	0.0%	0.0%	0.0%	0.0%	0.0%	0.0%	0.0%	0.0%	0.0%	0.0%	0.0%	0.0%	0.0%	0.0%	0.0%	0.0%	0.0%	0.0%	0.0%	0.0%	0.0%	0.0%	0.0%	0.0%	20.0%	0.0%

Project : VBH Malta NY  
 Site : Site 4  
 Location : 42.948550, -73.790036  
 Survey Date : 2021-04-28, Wednesday

### Turning Movement Data Plot

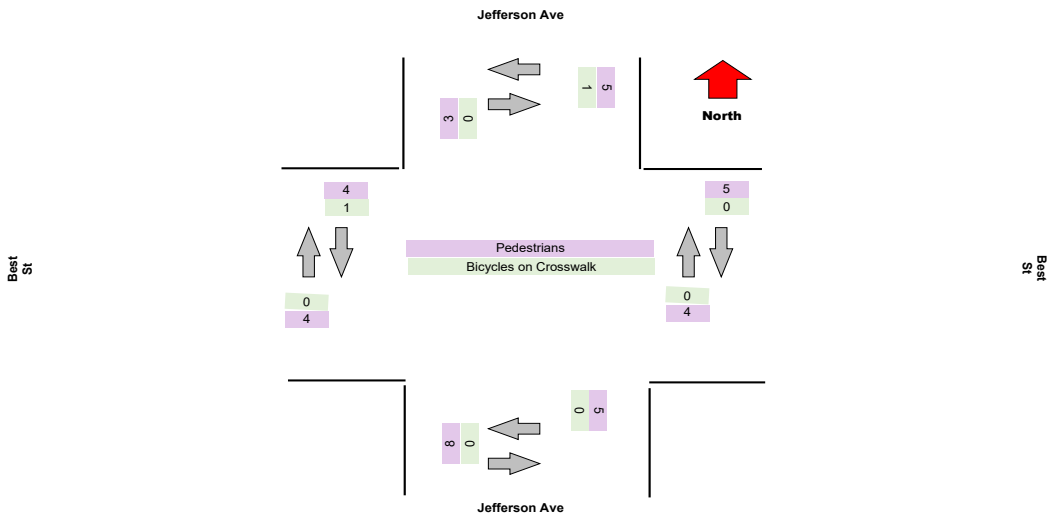
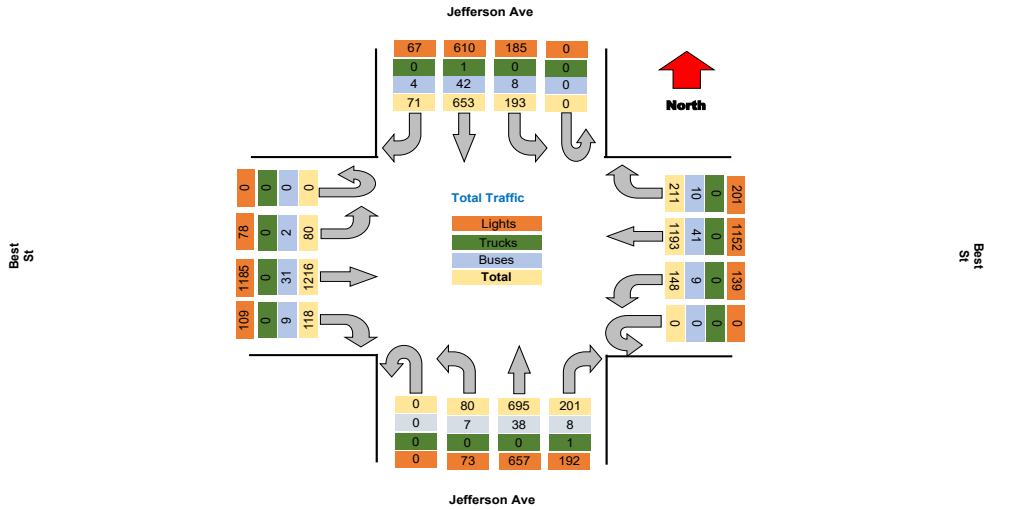

Project : VBH Malta NY  
Site : Site 4  
Location : 42.948550, -73.790036  
Survey Date : 2021-04-28, Wednesday

TSTData.com

**Turning Movement Peak Hour Data (AM)**

7:30:00 AM

Leg Direction	Jefferson Ave										Best St										Jefferson Ave										Best St										Total
	Southbound					Northbound					Westbound					Eastbound					Northbound					Eastbound															
Start Time	Right	Thru	Left	U-Turn	App Total	Peds CW	Peds CCW	Right	Thru	Left	U-Turn	App Total	Peds CW	Peds CCW	Right	Thru	Left	U-Turn	App Total	Peds CW	Peds CCW	Right	Thru	Left	U-Turn	App Total	Peds CW	Peds CCW	Total												
7:30:00 AM	5	30	12	0	47	0	0	7	81	7	0	95	0	1	9	32	2	0	44	1	0	7	81	4	0	92	0	0	278												
7:45:00 AM	10	49	9	0	68	0	0	10	106	19	0	135	0	0	12	36	8	0	56	0	0	9	96	3	0	108	0	0	367												
8:00:00 AM	5	51	12	0	68	0	0	15	105	10	0	130	0	1	15	35	4	0	55	1	0	16	92	7	0	115	0	0	368												
8:15:00 AM	2	35	6	0	43	0	0	19	74	5	0	100	0	0	6	37	5	0	48	1	0	5	60	5	0	70	0	1	261												
<b>Grand Total</b>	<b>22</b>	<b>165</b>	<b>39</b>	<b>0</b>	<b>226</b>	<b>0</b>	<b>0</b>	<b>51</b>	<b>366</b>	<b>41</b>	<b>0</b>	<b>459</b>	<b>0</b>	<b>2</b>	<b>42</b>	<b>140</b>	<b>19</b>	<b>0</b>	<b>293</b>	<b>3</b>	<b>0</b>	<b>37</b>	<b>329</b>	<b>19</b>	<b>0</b>	<b>385</b>	<b>0</b>	<b>1</b>	<b>1274</b>												
% Approach	9.7%	73.0%	17.3%	0.0%	0.0%	0.0%	0.0%	11.1%	79.6%	8.9%	0.0%	0.0%	0.0%	0.0%	20.7%	69.0%	9.4%	0.0%	0.0%	0.0%	0.0%	9.6%	85.5%	4.9%	0.0%	0.0%	0.0%	0.0%													
% Total	1.7%	13.0%	3.1%	0.0%	17.7%	0.0%	0.0%	4.0%	28.7%	3.2%	0.0%	36.1%	0.0%	0.0%	3.3%	11.0%	1.5%	0.0%	15.9%	0.0%	0.0%	2.9%	25.8%	1.5%	0.0%	30.2%	0.0%	0.0%													
PHF	0.550	0.809	0.613	0.000	0.831	0.000	0.000	0.671	0.863	0.539	0.000	0.852	0.000	0.000	0.700	0.946	0.594	0.000	0.906	0.000	0.000	0.578	0.857	0.679	0.000	0.837	0.000	0.000	0.965												
Lights	19	148	37	0	204	0	0	49	352	39	0	440	0	0	38	126	15	0	179	0	0	31	324	19	0	374	0	0	1197												
% Lights	86.4%	89.7%	94.9%	0.0%	90.3%	0.0%	0.0%	96.1%	96.2%	95.1%	0.0%	95.7%	0.0%	0.0%	90.5%	90.0%	78.9%	0.0%	88.2%	0.0%	0.0%	83.8%	98.5%	100.0%	0.0%	97.1%	0.0%	0.0%	94.0%												
Trucks	0	0	0	0	0	0	0	0	0	0	0	0	0	0	0	0	0	0	0	0	0	0	0	0	0	0	0	0	0												
% Trucks	0.0%	0.0%	0.0%	0.0%	0.0%	0.0%	0.0%	0.0%	0.0%	0.0%	0.0%	0.0%	0.0%	0.0%	0.0%	0.0%	0.0%	0.0%	0.0%	0.0%	0.0%	0.0%	0.0%	0.0%	0.0%	0.0%	0.0%	0.0%	0.0%												
Buses	3	17	2	0	22	0	0	2	14	2	0	18	0	0	4	14	4	0	22	0	0	6	5	0	0	11	0	0	73												
% Buses	13.6%	10.3%	5.1%	0.0%	0.0%	0.0%	0.0%	3.9%	3.8%	4.9%	0.0%	0.0%	0.0%	0.0%	9.5%	10.0%	21.1%	0.0%	0.0%	0.0%	0.0%	16.2%	1.5%	0.0%	0.0%	0.0%	0.0%	0.0%	5.7%												
Pedestrians	0	0	0	0	0	0	2	0	0	0	0	0	2	0	0	0	0	0	0	3	0	0	0	0	0	0	0	0	1												
% Pedestrians	0.0%	0.0%	0.0%	0.0%	0.0%	0.0%	100.0%	0.0%	0.0%	0.0%	0.0%	0.0%	0.0%	100.0%	0.0%	0.0%	0.0%	0.0%	0.0%	100.0%	0.0%	0.0%	0.0%	0.0%	0.0%	0.0%	0.0%	0.0%	100.0%												
Bicycles on Crosswalk	0	0	0	0	0	0	0	0	0	0	0	0	0	0	0	0	0	0	0	0	0	0	0	0	0	0	0	0	0												
% Bicycles on Crosswalk	0.0%	0.0%	0.0%	0.0%	0.0%	0.0%	0.0%	0.0%	0.0%	0.0%	0.0%	0.0%	0.0%	0.0%	0.0%	0.0%	0.0%	0.0%	0.0%	0.0%	0.0%	0.0%	0.0%	0.0%	0.0%	0.0%	0.0%	0.0%	0.0%												

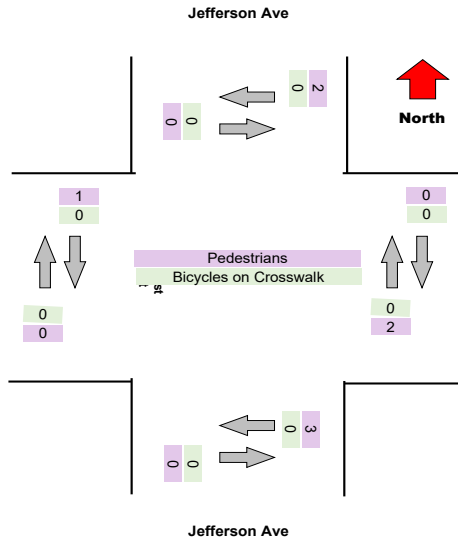
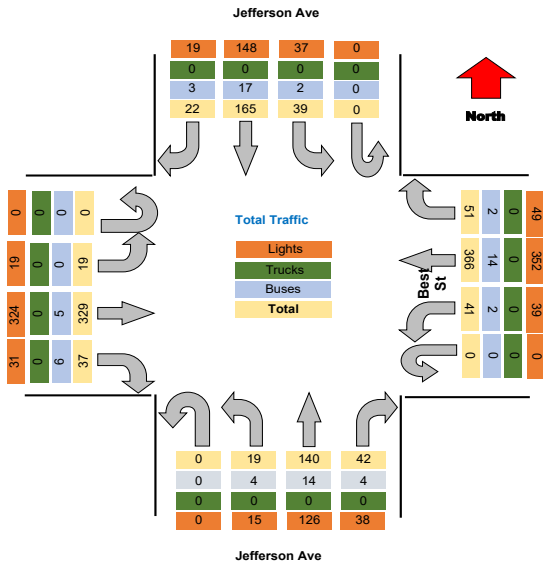

**Turning Movement Peak Hour Data (PM)**

4:15:00 PM

Leg Direction	Jefferson Ave				Best St				Jefferson Ave				Best St				Total												
	Southbound				Westbound				Northbound				Eastbound																
Start Time	Right	Thru	Left	U-Turn	App Total	Peds CW	Peds CCW	Right	Thru	Left	U-Turn	App Total	Peds CW	Peds CCW	Right	Thru	Left	U-Turn	App Total	Peds CW	Peds CCW								
4:15:00 PM	4	52	22	0	78	0	0	19	82	10	0	111	1	0	17	59	6	0	82	0	0	112	0	0					
4:30:00 PM	9	63	20	0	92	0	0	7	65	10	0	82	0	0	22	48	5	0	75	0	1	8	109	2	0	119	0	0	368
4:45:00 PM	3	44	10	0	57	0	0	13	65	4	0	82	0	0	18	61	3	0	82	0	1	12	86	5	0	103	0	0	324
5:00:00 PM	6	63	14	0	83	0	0	19	74	11	0	104	1	0	17	73	10	0	100	2	2	10	105	3	0	118	0	0	405
<b>Grand Total</b>	<b>22</b>	<b>222</b>	<b>66</b>	<b>0</b>	<b>310</b>	<b>0</b>	<b>0</b>	<b>58</b>	<b>286</b>	<b>35</b>	<b>0</b>	<b>379</b>	<b>2</b>	<b>0</b>	<b>74</b>	<b>281</b>	<b>24</b>	<b>0</b>	<b>379</b>	<b>2</b>	<b>4</b>	<b>39</b>	<b>409</b>	<b>13</b>	<b>0</b>	<b>452</b>	<b>0</b>	<b>0</b>	<b>1489</b>
% Approach	7.1%	71.6%	21.3%	0.0%	0.0%	0.0%	0.0%	15.3%	75.5%	9.2%	0.0%	0.0%	0.0%	0.0%	21.8%	71.1%	7.1%	0.0%	0.0%	0.0%	0.0%	8.6%	85.5%	2.9%	0.0%	0.0%	0.0%	0.0%	0.0%
% Total	1.5%	15.0%	4.5%	0.0%	20.8%	0.0%	0.0%	3.9%	19.3%	2.4%	0.0%	25.6%	0.0%	0.0%	5.0%	16.3%	1.6%	0.0%	22.9%	0.0%	0.0%	2.6%	27.0%	0.9%	0.0%	30.5%	0.0%	0.0%	0.0%
PHF	0.611	0.881	0.750	0.000	0.842	0.000	0.000	0.763	0.872	0.795	0.000	0.854	0.000	0.000	0.841	0.825	0.600	0.000	0.848	0.000	0.000	0.813	0.917	0.650	0.000	0.950	0.000	0.000	0.914
Lights	22	213	64	0	299	0	0	55	279	31	0	365	0	0	73	233	22	0	328	0	0	38	389	12	0	439	0	0	1431
% Lights	100.0%	95.9%	97.0%	0.0%	96.5%	0.0%	0.0%	94.8%	97.6%	88.6%	0.0%	96.3%	0.0%	0.0%	88.6%	96.7%	91.7%	0.0%	96.8%	0.0%	0.0%	97.4%	97.3%	92.3%	0.0%	97.1%	0.0%	0.0%	96.7%
Trucks	0	0	0	0	0	0	0	0	0	0	0	0	0	0	0	0	0	0	0	0	0	0	0	0	0	0	0	0	0
% Trucks	0.0%	0.0%	0.0%	0.0%	0.0%	0.0%	0.0%	0.0%	0.0%	0.0%	0.0%	0.0%	0.0%	0.0%	0.0%	0.0%	0.0%	0.0%	0.0%	0.0%	0.0%	0.0%	0.0%	0.0%	0.0%	0.0%	0.0%	0.0%	0.0%
Buses	0	9	2	0	11	0	0	3	7	4	0	14	0	0	1	8	2	0	11	0	0	1	11	1	0	13	0	0	49
% Buses	0.0%	4.1%	3.0%	0.0%	0.0%	0.0%	0.0%	5.2%	2.4%	11.4%	0.0%	0.0%	0.0%	0.0%	1.4%	3.3%	8.3%	0.0%	0.0%	0.0%	0.0%	2.6%	2.8%	7.7%	0.0%	0.0%	0.0%	0.0%	3.3%
Pedestrians	0	0	0	0	0	0	0	0	0	0	0	0	2	4	0	0	0	0	0	0	0	0	0	0	0	0	0	0	0
% Pedestrians	0.0%	0.0%	0.0%	0.0%	0.0%	100.0%	0.0%	0.0%	0.0%	0.0%	0.0%	0.0%	100.0%	100.0%	0.0%	0.0%	0.0%	0.0%	0.0%	0.0%	0.0%	0.0%	0.0%	0.0%	0.0%	0.0%	0.0%	0.0%	0.0%
Bicycles on Crosswalk	0	0	0	0	0	0	0	0	0	0	0	0	0	0	0	0	0	0	0	0	0	0	0	0	0	0	0	0	0
% Bicycles on Crosswalk	0.0%	0.0%	0.0%	0.0%	0.0%	0.0%	0.0%	0.0%	0.0%	0.0%	0.0%	0.0%	0.0%	0.0%	0.0%	0.0%	0.0%	0.0%	0.0%	0.0%	0.0%	0.0%	0.0%	0.0%	0.0%	0.0%	0.0%	0.0%	0.0%

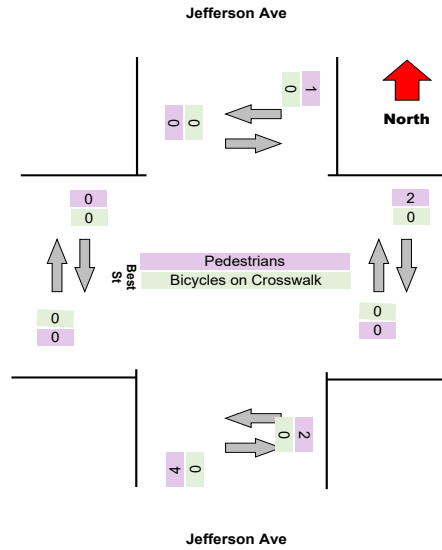
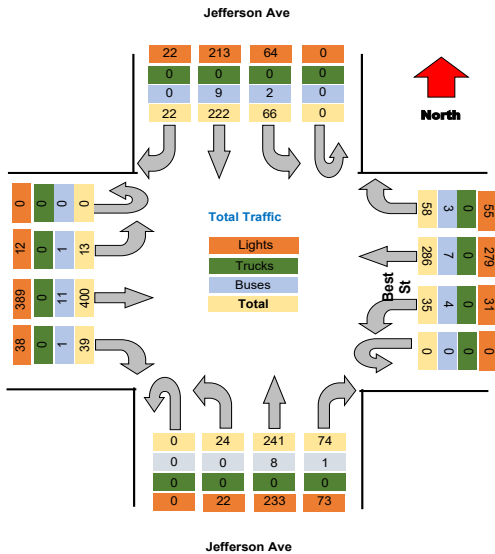



Project : VBH Malta NY  
 Site : Site 4  
 Location : 42.948550, -73.790036  
 Survey Date : 2021-04-28, Wednesday

### Turning Movement Data Plot

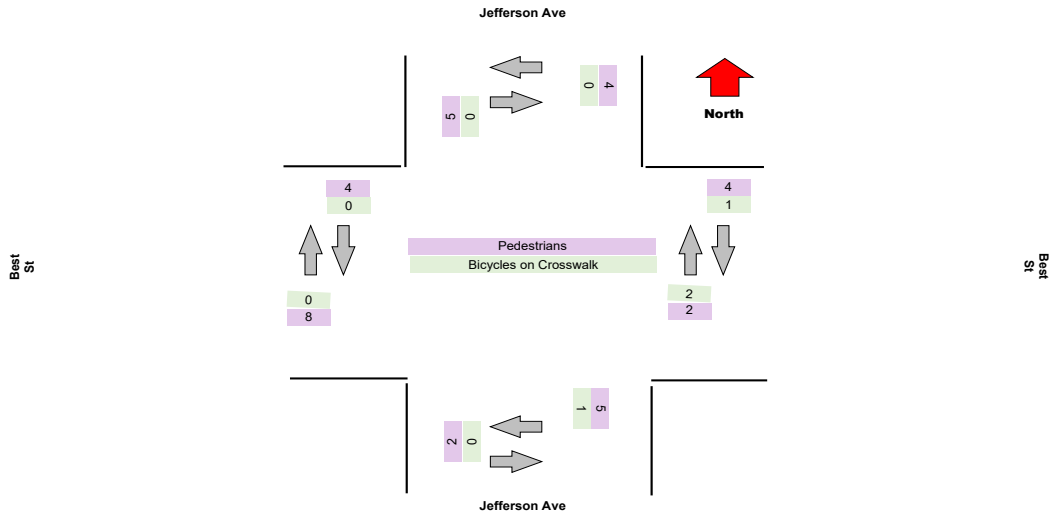
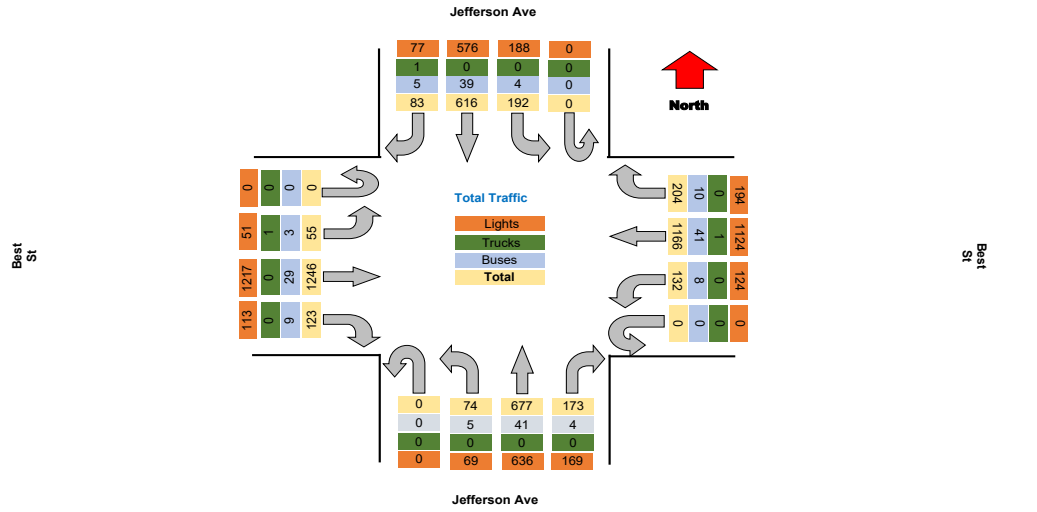



Project : VBH Malta NY  
Site : Site 4  
Location : 42.948550, -73.790036

TSTData.com

Survey Date : 2021-04-28, Wednesday

### Turning Movement Peak Hour Data (AM)

7:30:00 AM

Leg Direction	Jefferson Ave					Best St					Jefferson Ave					Best St					Total
	Southbound		Northbound			Westbound		Eastbound			Northbound		Eastbound								
Start Time	Right	Thru	Left	U-Turn	App Total	Peds CW	Peds CCW	Right	Thru	Left	U-Turn	App Total	Peds CW	Peds CCW	Right	Thru	Left	U-Turn	App Total	Peds CW	Peds CCW
7:30:00 AM	4	35	11	0	50	0	0	8	69	9	0	86	0	0	11	35	3	0	49	1	0
7:45:00 AM	8	29	8	0	45	0	1	20	113	17	0	151	0	0	9	42	7	0	58	0	0
8:00:00 AM	5	29	7	0	41	0	0	11	95	14	0	120	0	0	12	45	6	0	63	0	0
8:15:00 AM	6	35	7	0	48	0	1	17	85	9	0	112	0	0	8	38	2	0	48	1	0
<b>Grand Total</b>	<b>23</b>	<b>138</b>	<b>33</b>	<b>0</b>	<b>194</b>	<b>0</b>	<b>2</b>	<b>55</b>	<b>392</b>	<b>49</b>	<b>0</b>	<b>459</b>	<b>0</b>	<b>0</b>	<b>40</b>	<b>190</b>	<b>18</b>	<b>0</b>	<b>248</b>	<b>2</b>	<b>0</b>
% Approach	11.9%	71.1%	17.0%	0.0%	0.0%	0.0%	0.0%	11.9%	77.2%	10.4%	0.0%	0.0%	0.0%	0.0%	18.3%	73.4%	8.3%	0.0%	0.0%	0.0%	0.0%
% Total	1.8%	10.7%	2.6%	0.0%	15.0%	0.0%	0.0%	4.3%	28.0%	3.8%	0.0%	36.3%	0.0%	0.0%	3.1%	12.4%	1.4%	0.0%	16.9%	0.0%	0.0%
PHF	0.719	0.885	0.750	0.000	0.951	0.000	0.000	0.700	0.801	0.721	0.000	0.776	0.000	0.000	0.833	0.889	0.643	0.000	0.865	0.000	0.000
Lights	18	128	32	0	178	0	0	53	349	47	0	449	0	0	38	147	14	0	199	0	0
% Lights	78.3%	82.8%	97.0%	0.0%	91.8%	0.0%	0.0%	84.6%	96.4%	95.9%	0.0%	95.7%	0.0%	0.0%	95.0%	91.9%	77.8%	0.0%	91.3%	0.0%	0.0%
Trucks	1	0	0	0	1	0	0	0	0	0	0	0	0	0	0	0	0	0	0	0	0
% Trucks	4.3%	0.0%	0.0%	0.0%	0.5%	0.0%	0.0%	0.0%	0.0%	0.0%	0.0%	0.0%	0.0%	0.0%	0.0%	0.0%	0.0%	0.0%	0.0%	0.0%	0.0%
Buses	4	10	1	0	15	0	0	3	13	2	0	18	0	0	2	13	4	0	19	0	0
% Buses	17.4%	7.2%	3.0%	0.0%	0.0%	0.0%	0.0%	5.4%	3.6%	4.1%	0.0%	0.0%	0.0%	0.0%	5.0%	8.1%	22.2%	0.0%	0.0%	0.0%	0.0%
Pedestrians	0	0	0	0	0	0	2	0	0	0	0	0	0	2	0	0	0	0	0	0	1
% Pedestrians	0.0%	0.0%	0.0%	0.0%	0.0%	0.0%	100.0%	0.0%	0.0%	0.0%	0.0%	0.0%	0.0%	0.0%	0.0%	0.0%	0.0%	0.0%	0.0%	0.0%	100.0%
Bicycles on Crosswalk	0	0	0	0	0	0	0	0	0	0	0	0	0	0	0	0	0	0	0	0	0
% Bicycles on Crosswalk	0.0%	0.0%	0.0%	0.0%	0.0%	0.0%	0.0%	0.0%	0.0%	0.0%	0.0%	0.0%	0.0%	0.0%	0.0%	0.0%	0.0%	0.0%	0.0%	0.0%	0.0%

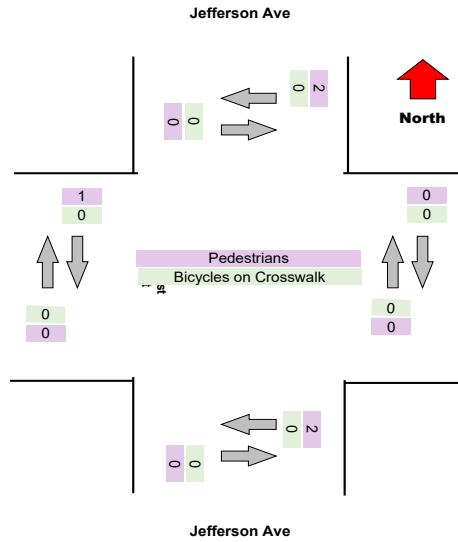
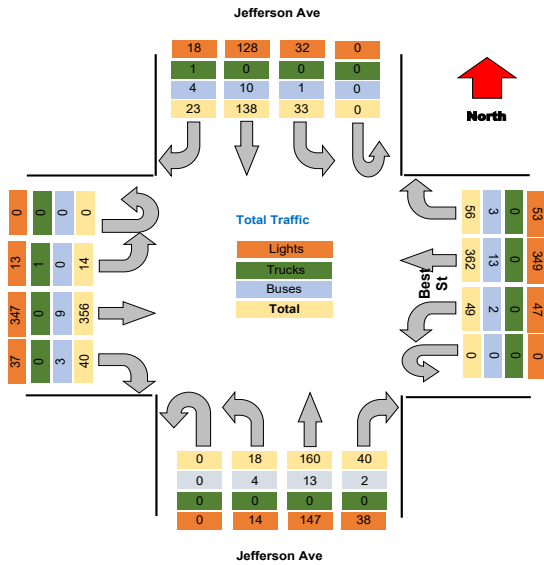

**Turning Movement Peak Hour Data (PM)**

4:15:00 PM

Leg Direction	Jefferson Ave										Best St				Jefferson Ave										Best St				Total
	Southbound					Westbound					Northbound				Eastbound														
	Right	Thru	Left	U-Turn	App Total	Peds CW	Peds CCW	Right	Thru	Left	U-Turn	App Total	Peds CW	Peds CCW	Right	Thru	Left	U-Turn	App Total	Peds CW	Peds CCW	Right	Thru	Left	U-Turn	App Total	Peds CW	Peds CCW	
4:15:00 PM	5	61	12	0	78	0	0	12	71	1	0	84	0	2	11	51	6	0	68	0	0	12	97	10	0	119	0	0	349
4:30:00 PM	6	50	20	0	76	0	0	16	49	6	0	71	0	1	19	58	7	0	84	1	0	9	104	6	0	119	1	0	350
4:45:00 PM	5	40	18	0	63	0	0	17	56	9	0	82	0	0	10	61	8	0	79	0	1	10	96	3	0	109	0	1	333
5:00:00 PM	10	57	15	0	82	0	0	10	65	3	0	78	0	0	11	61	5	0	77	0	0	7	103	5	0	115	0	0	352
<b>Grand Total</b>	<b>28</b>	<b>228</b>	<b>65</b>	<b>0</b>	<b>299</b>	<b>0</b>	<b>0</b>	<b>55</b>	<b>241</b>	<b>19</b>	<b>0</b>	<b>315</b>	<b>0</b>	<b>3</b>	<b>51</b>	<b>231</b>	<b>26</b>	<b>0</b>	<b>308</b>	<b>1</b>	<b>1</b>	<b>38</b>	<b>409</b>	<b>24</b>	<b>0</b>	<b>462</b>	<b>1</b>	<b>1</b>	<b>1384</b>
% Approach	8.7%	69.6%	21.7%	0.0%	0.0%	0.0%	0.0%	17.5%	76.5%	6.0%	0.0%	0.0%	0.0%	0.0%	16.6%	75.0%	8.4%	0.0%	0.0%	0.0%	0.0%	8.2%	86.6%	5.2%	0.0%	0.0%	0.0%	0.0%	0.0%
% Total	1.9%	15.0%	4.7%	0.0%	21.6%	0.0%	0.0%	4.0%	17.4%	1.4%	0.0%	22.8%	0.0%	0.0%	3.7%	16.7%	1.9%	0.0%	22.3%	0.0%	0.0%	2.7%	28.9%	1.7%	0.0%	33.4%	0.0%	0.0%	0.0%
PHF	0.650	0.852	0.613	0.000	0.912	0.000	0.000	0.809	0.849	0.528	0.000	0.938	0.000	0.000	0.671	0.947	0.813	0.000	0.917	0.000	0.000	0.792	0.962	0.600	0.000	0.971	0.000	0.000	0.983
Lights	26	196	64	0	286	0	0	54	231	16	0	301	0	0	51	222	25	0	298	0	0	36	393	22	0	451	0	0	1336
% Lights	100.0%	94.2%	98.5%	0.0%	95.7%	0.0%	0.0%	98.2%	95.9%	84.2%	0.0%	95.6%	0.0%	0.0%	100.0%	96.1%	96.2%	0.0%	96.8%	0.0%	0.0%	94.7%	98.3%	91.7%	0.0%	97.6%	0.0%	0.0%	96.5%
Trucks	0	0	0	0	0	0	0	0	0	0	0	0	0	0	0	0	0	0	0	0	0	0	0	0	0	0	0	0	0
% Trucks	0.0%	0.0%	0.0%	0.0%	0.0%	0.0%	0.0%	0.0%	0.0%	0.0%	0.0%	0.0%	0.0%	0.0%	0.0%	0.0%	0.0%	0.0%	0.0%	0.0%	0.0%	0.0%	0.0%	0.0%	0.0%	0.0%	0.0%	0.0%	0.0%
Buses	0	12	1	0	13	0	0	1	10	3	0	14	0	0	0	9	1	0	10	0	0	2	7	2	0	11	0	0	48
% Buses	0.0%	5.8%	1.5%	0.0%	0.0%	0.0%	0.0%	1.8%	4.1%	15.8%	0.0%	0.0%	0.0%	0.0%	0.0%	3.9%	3.8%	0.0%	0.0%	0.0%	0.0%	5.3%	1.8%	8.3%	0.0%	0.0%	0.0%	3.5%	
Pedestrians	0	0	0	0	0	0	2	0	0	0	0	2	0	0	0	0	0	1	0	0	0	0	0	0	0	0	1	1	0
% Pedestrians	0.0%	0.0%	0.0%	0.0%	0.0%	0.0%	100.0%	0.0%	0.0%	0.0%	0.0%	0.0%	66.7%	0.0%	0.0%	0.0%	0.0%	0.0%	0.0%	0.0%	0.0%	0.0%	0.0%	0.0%	0.0%	0.0%	100.0%	100.0%	0.0%
Bicycles on Crosswalk	0	0	0	0	0	0	0	0	0	0	0	0	1	0	0	0	0	0	1	0	0	0	0	0	0	0	0	0	0
% Bicycles on Crosswalk	0.0%	0.0%	0.0%	0.0%	0.0%	0.0%	0.0%	0.0%	0.0%	0.0%	0.0%	0.0%	33.3%	0.0%	0.0%	0.0%	0.0%	0.0%	0.0%	100.0%	0.0%	0.0%	0.0%	0.0%	0.0%	0.0%	0.0%	0.0%	0.0%

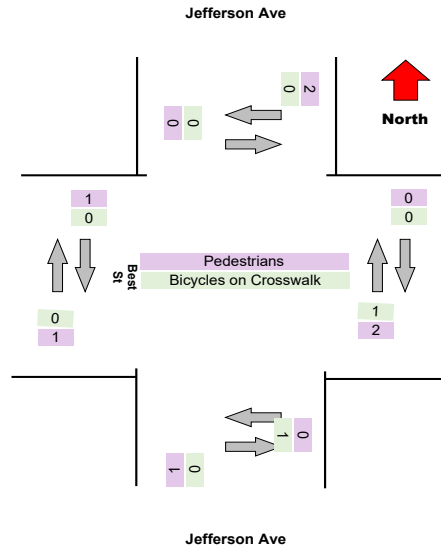
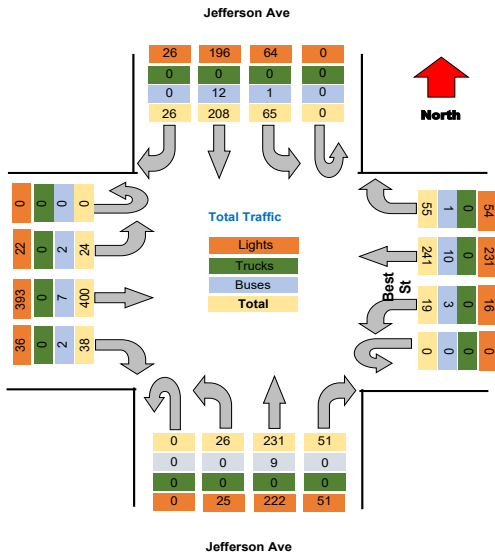

Project	LaBella
Project Code	LaBella
Site Name	37
Legs and Movements	All Processed Legs & Movements
Bin Size	15 minutes
Survey Date	2021-11-02, Tuesday
Location	37
Latitude and Longitude	42.902086, -78.853994

	Start	End	PHF
Forced Peak AM	2021/11/02 07:30:00	2021/11/02 08:30:00	0.887168142
Forced Peak PM	2021/11/02 16:30:00	2021/11/02 17:30:00	0.901408451
AM Peak	2021/11/02 07:30:00	2021/11/02 08:30:00	0.887168142
PM Peak	2021/11/02 16:15:00	2021/11/02 17:15:00	0.872065728

Turning Movement Data

Leg Direction	Jefferson Ave Southbound						Jefferson Ave NorthBound						E North St Eastbound			
	Right	Thru	U-Turn	App Total	Peds CW	Peds CCW	Thru	Left	U-Turn	App Total	Peds CW	Peds CCW	Right	Left	U-Turn	App Total
Start Time	9	11	0	20	0	0	14	13	0	27	0	0	2	4	0	6
6:30:00 AM	9	11	0	20	0	0	14	13	0	27	0	0	2	4	0	6
6:45:00 AM	10	18	0	28	0	0	19	25	0	44	0	0	10	2	0	12
Hourly Total	19	29	0	48	0	0	33	38	0	71	0	0	12	6	0	18
7:00:00 AM	5	15	0	20	0	0	16	9	0	25	0	0	13	6	0	19
7:15:00 AM	5	23	0	28	0	0	19	14	0	33	1	0	6	4	0	11
7:30:00 AM	9	21	0	30	0	0	31	19	0	50	0	0	13	10	0	23
7:45:00 AM	6	31	0	37	0	0	24	21	0	45	0	0	7	3	0	10
Hourly Total	25	90	0	115	0	0	90	63	0	153	1	0	39	23	0	63
8:00:00 AM	6	34	0	40	0	0	37	22	0	59	0	0	8	6	0	14
8:15:00 AM	4	35	0	39	0	0	21	17	0	38	0	0	8	8	0	16
Hourly Total	10	69	0	79	0	0	58	39	0	97	0	0	16	14	0	30
4:00:00 PM	10	55	0	65	0	0	54	12	0	66	0	0	39	19	0	58
4:15:00 PM	4	55	0	59	0	0	46	11	0	57	0	0	31	16	0	47
4:30:00 PM	5	68	0	73	0	0	58	10	0	68	1	0	47	25	0	72
4:45:00 PM	3	54	0	57	0	0	64	5	1	70	1	1	27	14	0	41
Hourly Total	22	232	0	254	0	0	222	38	1	261	2	1	144	74	0	218
5:00:00 PM	6	56	0	62	0	1	72	13	0	85	0	1	34	18	0	52
5:15:00 PM	3	71	0	74	0	0	55	14	0	69	0	1	27	18	0	45
5:30:00 PM	2	42	0	44	1	0	55	9	0	64	0	0	21	16	0	37
5:45:00 PM	4	53	0	57	0	0	51	6	0	57	1	1	16	7	0	23
Hourly Total	15	222	0	237	1	1	233	42	0	275	1	3	98	59	0	157
Grand Total	91	642	0	733	1	1	636	220	1	857	4	4	309	176	0	486
% Approach	12.4%	87.6%	0.0%	0.0%	0.0%	0.0%	74.2%	25.7%	0.1%	0.0%	0.0%	0.0%	63.6%	36.2%	0.0%	0.0%
% Total	4.4%	30.9%	0.0%	35.3%	0.0%	0.0%	30.6%	10.6%	0.0%	41.3%	0.0%	0.0%	14.9%	8.5%	0.0%	23.4%
Lights	89	631	0	720	0	0	619	218	1	838	0	0	305	176	0	481
% Lights	97.8%	98.3%	0.0%	98.2%	0.0%	0.0%	97.3%	99.1%	100.0%	97.8%	0.0%	0.0%	98.7%	100.0%	0.0%	99.0%
Trucks	0	1	0	1	0	0	0	0	0	0	0	0	0	0	0	0
% Trucks	0.0%	0.2%	0.0%	0.1%	0.0%	0.0%	0.0%	0.0%	0.0%	0.0%	0.0%	0.0%	0.0%	0.0%	0.0%	0.0%
Buses	2	9	0	11	0	0	16	2	0	18	0	0	4	0	0	4
% Buses	2.2%	1.4%	0.0%	0.0%	0.0%	0.0%	0.0%	0.9%	0.0%	0.0%	0.0%	0.0%	1.3%	0.0%	0.0%	0.0%
Pedestrians	0	0	0	0	1	1	0	0	0	0	4	4	0	0	0	0
% Pedestrians	0.0%	0.0%	0.0%	0.0%	100.0%	100.0%	0.0%	0.0%	0.0%	0.0%	100.0%	100.0%	0.0%	0.0%	0.0%	0.0%
Bicycles on Crosswalk	0	0	0	0	0	0	0	0	0	0	0	0	0	0	0	0
% Bicycles on Crosswalk	0.0%	0.0%	0.0%	0.0%	0.0%	0.0%	0.0%	0.0%	0.0%	0.0%	0.0%	0.0%	0.0%	0.0%	0.0%	0.0%

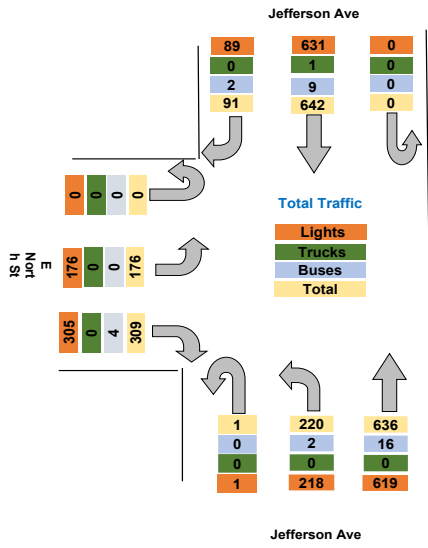

Turning Movement Data Plot

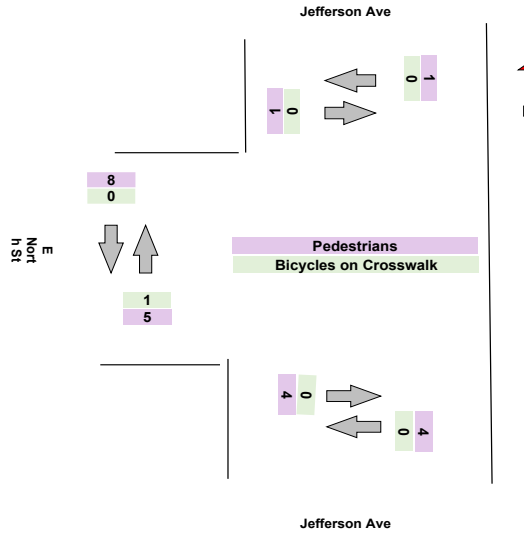

Turning Movement Peak Hour Data (AM)

7:30:00 AM

Leg Direction	Jefferson Ave Southbound						Jefferson Ave NorthBound						E North St Eastbound			
	Right	Thru	U-Turn	App Total	Peds CW	Peds CCW	Thru	Left	U-Turn	App Total	Peds CW	Peds CCW	Right	Left	U-Turn	App Total
7:30:00 AM	9	21	0	30	0	0	31	19	0	50	0	0	13	10	0	23
7:45:00 AM	6	31	0	37	0	0	24	21	0	45	0	0	7	3	0	10
8:00:00 AM	6	34	0	40	0	0	37	22	0	59	0	0	8	6	0	14
8:15:00 AM	4	35	0	39	0	0	21	17	0	38	0	0	8	8	0	16
<b>Grand Total</b>	<b>25</b>	<b>121</b>	<b>0</b>	<b>146</b>	<b>0</b>	<b>0</b>	<b>113</b>	<b>79</b>	<b>0</b>	<b>192</b>	<b>0</b>	<b>0</b>	<b>36</b>	<b>27</b>	<b>0</b>	<b>63</b>
% Approach	17.1%	82.9%	0.0%	0.0%	0.0%	0.0%	58.9%	41.1%	0.0%	0.0%	0.0%	0.0%	57.1%	42.9%	0.0%	0.0%
% Total	6.2%	30.2%	0.0%	36.4%	0.0%	0.0%	28.2%	19.7%	0.0%	47.9%	0.0%	0.0%	9.0%	6.7%	0.0%	15.7%
PHF	0.694	0.864	0.000	0.913	0.000	0.000	0.764	0.898	0.000	0.814	0.000	0.000	0.692	0.675	0.000	0.685
Lights	23	119	0	142	0	0	110	78	0	188	0	0	35	27	0	62
% Lights	92.0%	98.3%	0.0%	97.3%	0.0%	0.0%	97.3%	98.7%	0.0%	97.9%	0.0%	0.0%	97.2%	100.0%	0.0%	98.4%
Trucks	0	0	0	0	0	0	0	0	0	0	0	0	0	0	0	0
% Trucks	0.0%	0.0%	0.0%	0.0%	0.0%	0.0%	0.0%	0.0%	0.0%	0.0%	0.0%	0.0%	0.0%	0.0%	0.0%	0.0%
Buses	2	2	0	4	0	0	3	1	0	4	0	0	1	0	0	1
% Buses	8.0%	1.7%	0.0%	0.0%	0.0%	0.0%	2.7%	1.3%	0.0%	0.0%	0.0%	0.0%	2.8%	0.0%	0.0%	0.0%
Pedestrians	0	0	0	0	0	0	0	0	0	0	0	0	0	0	0	0
% Pedestrians	0.0%	0.0%	0.0%	0.0%	0.0%	0.0%	0.0%	0.0%	0.0%	0.0%	0.0%	0.0%	0.0%	0.0%	0.0%	0.0%
Bicycles on Crosswalk	0	0	0	0	0	0	0	0	0	0	0	0	0	0	0	0
% Bicycles on Crosswalk	0.0%	0.0%	0.0%	0.0%	0.0%	0.0%	0.0%	0.0%	0.0%	0.0%	0.0%	0.0%	0.0%	0.0%	0.0%	0.0%

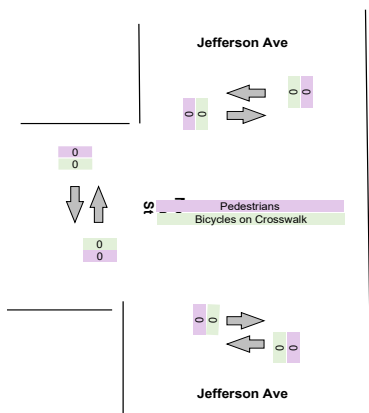
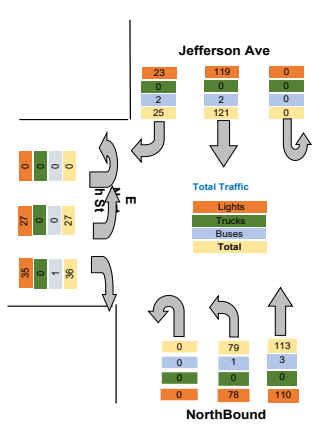

Turning Movement Peak Hour Data (PM)  
 4:15:00 PM

Leg Direction	Jefferson Ave Southbound						Jefferson Ave Northbound						E North St Eastbound			
	Right	Thru	U-Turn	App Total	Peds CW	Peds CCW	Thru	Left	U-Turn	App Total	Peds CW	Peds CCW	Right	Left	U-Turn	App Total
4:15:00 PM	4	55	0	59	0	0	46	11	0	57	0	0	31	16	0	47
4:30:00 PM	5	68	0	73	0	0	58	10	0	68	1	0	47	25	0	72
4:45:00 PM	3	54	0	57	0	0	64	5	1	70	1	1	27	14	0	41
5:00:00 PM	6	56	0	62	0	1	72	13	0	85	0	1	34	18	0	52
<b>Grand Total</b>	18	233	0	251	0	1	240	39	1	280	2	2	139	73	0	212
% Approach	7.2%	92.8%	0.0%	0.0%	0.0%	0.0%	85.7%	13.9%	0.4%	0.0%	0.0%	0.0%	65.6%	34.4%	0.0%	0.0%
% Total	2.4%	31.4%	0.0%	33.8%	0.0%	0.0%	32.3%	5.2%	0.1%	37.7%	0.0%	0.0%	18.7%	9.8%	0.0%	28.5%
PHF	0.750	0.857	0.000	0.860	0.000	0.000	0.833	0.750	0.250	0.824	0.000	0.000	0.739	0.730	0.000	0.736
Lights	18	228	0	246	0	0	233	39	1	273	0	0	138	73	0	211
% Lights	100.0%	97.9%	0.0%	98.0%	0.0%	0.0%	97.1%	100.0%	100.0%	97.5%	0.0%	0.0%	99.3%	100.0%	0.0%	99.5%
Trucks	0	1	0	1	0	0	0	0	0	0	0	0	0	0	0	0
% Trucks	0.0%	0.4%	0.0%	0.4%	0.0%	0.0%	0.0%	0.0%	0.0%	0.0%	0.0%	0.0%	0.0%	0.0%	0.0%	0.0%
Buses	0	3	0	3	0	0	6	0	0	6	0	0	1	0	0	1
% Buses	0.0%	1.3%	0.0%	0.0%	0.0%	0.0%	2.5%	0.0%	0.0%	0.0%	0.0%	0.0%	0.7%	0.0%	0.0%	0.0%
Pedestrians	0	0	0	0	0	1	0	0	0	0	2	2	0	0	0	0
% Pedestrians	0.0%	0.0%	0.0%	0.0%	0.0%	100.0%	0.0%	0.0%	0.0%	0.0%	100.0%	100.0%	0.0%	0.0%	0.0%	0.0%
Bicycles on Crosswalk	0	0	0	0	0	0	0	0	0	0	0	0	0	0	0	0
% Bicycles on Crosswalk	0.0%	0.0%	0.0%	0.0%	0.0%	0.0%	0.0%	0.0%	0.0%	0.0%	0.0%	0.0%	0.0%	0.0%	0.0%	0.0%

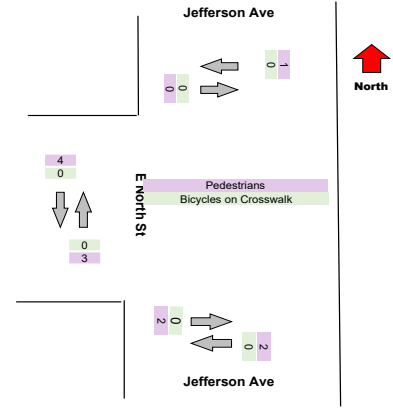
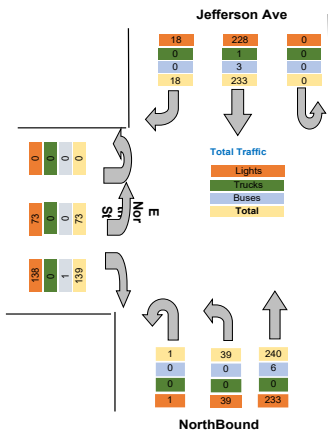

Intersection: Elm St Pine St  
 Location: Kennett Square, PA  
 Site: 01  
 Survey Date: Wednesday, 04-28-2021  
 GPS: 42.948550, -72.790034

Peds CW	Peds CCW	Total
0	0	53
0	0	84
<b>0</b>	<b>0</b>	<b>137</b>
0	0	64
0	0	72
0	0	103
0	0	92
<b>0</b>	<b>0</b>	<b>331</b>
0	0	113
0	0	93
<b>0</b>	<b>0</b>	<b>206</b>
0	0	189
1	0	163
1	1	213
1	2	168
<b>3</b>	<b>3</b>	<b>733</b>
0	1	199
1	1	188
0	1	145
2	2	137
<b>3</b>	<b>5</b>	<b>669</b>
6	8	2076
0.0%	0.0%	0.0%
0.0%	0.0%	0.0%
0	0	2039
0.0%	0.0%	98.2%
0	0	1
0.0%	0.0%	0.0%
0	0	33
0.0%	0.0%	1.6%
5	8	0
63.3%	100.0%	0.0%
1	0	0
16.7%	0.0%	0.0%

Intersection: Elm St Pine St  
 Location: Kennett Square, PA  
 Site: 01  
 Survey Date: Wednesday, 04-28-2021  
 GPS: 42.948550, -72.790034

Peds CW	Peds CCW	Total
0	0	<b>103</b>
0	0	<b>92</b>
0	0	<b>113</b>
0	0	<b>93</b>
0	0	<b>401</b>
0.0%	0.0%	
0.0%	0.0%	
0.000	0.000	<b>0.887</b>
0	0	<b>392</b>
0.0%	0.0%	<b>97.8%</b>
0	0	<b>0</b>
0.0%	0.0%	<b>0.0%</b>
0	0	<b>9</b>
0.0%	0.0%	<b>2.2%</b>
0	0	<b>0</b>
0.0%	0.0%	<b>0.0%</b>
0	0	<b>0</b>
0.0%	0.0%	<b>0.0%</b>



Intersection: Elm St Pine St  
 Location: Kennett Square, PA  
 Site: 01  
 Survey Date: Wednesday, 04-28-2021  
 GPS: 42.948550, -72.790034



Peds CW	Peds CCW	Total
1	0	163
1	1	213
1	2	168
0	1	199
3	4	743
0.0%	0.0%	
0.0%	0.0%	
0.000	0.000	0.872
0	0	730
0.0%	0.0%	98.3%
0	0	1
0.0%	0.0%	0.1%
0	0	10
0.0%	0.0%	1.3%
3	4	0
100.0%	100.0%	0.0%
0	0	0
0.0%	0.0%	0.0%

Project	LaBella
Project Code	LaBella
Site Name	37
Legs and Movements	All Processed Legs & Movements
Bin Size	15 minutes
Survey Date	2021-11-03, Wednesday
Location	37
Latitude and Longitude	42.902086, -78.853994

	Start	End	PHF
Forced Peak AM	2021/11/03 07:30:00	2021/11/03 08:30:00	0.826829268
Forced Peak PM	2021/11/03 16:30:00	2021/11/03 17:30:00	0.904816514
AM Peak	2021/11/03 07:30:00	2021/11/03 08:30:00	0.826829268
PM Peak	2021/11/03 16:15:00	2021/11/03 17:15:00	0.926605505

Turning Movement Data

Leg Direction	Jefferson Ave Southbound						Jefferson Ave Northbound						E North St Eastbound			
	Right	Thru	U-Turn	App Total	Peds CW	Peds CCW	Thru	Left	U-Turn	App Total	Peds CW	Peds CCW	Right	Left	U-Turn	App Total
Start Time																
6:30:00 AM	7	9	0	16	0	0	18	12	0	30	0	0	6	1	0	7
6:45:00 AM	9	19	0	28	0	0	28	23	0	51	0	0	8	1	0	9
<b>Hourly Total</b>	<b>16</b>	<b>28</b>	<b>0</b>	<b>44</b>	<b>0</b>	<b>0</b>	<b>46</b>	<b>35</b>	<b>0</b>	<b>81</b>	<b>0</b>	<b>0</b>	<b>14</b>	<b>2</b>	<b>0</b>	<b>16</b>
7:00:00 AM	11	29	0	40	0	0	29	25	0	54	0	0	10	5	0	15
7:15:00 AM	14	33	0	47	0	0	30	42	0	72	0	0	7	6	0	13
7:30:00 AM	10	34	0	44	0	0	33	42	0	75	2	0	19	11	0	32
7:45:00 AM	25	52	0	77	0	0	42	54	0	96	0	0	15	17	0	32
<b>Hourly Total</b>	<b>60</b>	<b>148</b>	<b>0</b>	<b>208</b>	<b>0</b>	<b>0</b>	<b>134</b>	<b>163</b>	<b>0</b>	<b>297</b>	<b>2</b>	<b>0</b>	<b>51</b>	<b>39</b>	<b>0</b>	<b>92</b>
8:00:00 AM	11	66	0	77	0	0	35	46	0	81	1	0	23	18	0	42
8:15:00 AM	4	41	0	45	0	0	39	15	0	54	0	0	14	9	0	23
<b>Hourly Total</b>	<b>15</b>	<b>107</b>	<b>0</b>	<b>122</b>	<b>0</b>	<b>0</b>	<b>74</b>	<b>61</b>	<b>0</b>	<b>135</b>	<b>1</b>	<b>0</b>	<b>37</b>	<b>27</b>	<b>0</b>	<b>65</b>
4:00:00 PM	4	58	0	62	0	0	77	13	0	90	0	2	46	22	0	68
4:15:00 PM	2	69	0	71	0	0	68	10	0	78	0	1	34	19	0	53
4:30:00 PM	10	71	0	81	0	0	55	14	0	69	2	0	36	15	0	51
4:45:00 PM	2	58	0	60	0	0	70	5	0	75	0	0	31	21	0	52
<b>Hourly Total</b>	<b>18</b>	<b>256</b>	<b>0</b>	<b>274</b>	<b>0</b>	<b>0</b>	<b>270</b>	<b>42</b>	<b>0</b>	<b>312</b>	<b>2</b>	<b>3</b>	<b>147</b>	<b>77</b>	<b>0</b>	<b>224</b>
5:00:00 PM	6	77	0	83	0	0	74	12	1	87	0	0	29	19	0	48
5:15:00 PM	5	57	0	62	0	0	64	15	0	79	0	0	30	12	0	42
5:30:00 PM	6	52	0	58	0	0	61	9	0	70	0	0	19	19	0	38
5:45:00 PM	4	64	0	68	0	0	53	20	0	73	0	0	21	11	0	32
<b>Hourly Total</b>	<b>21</b>	<b>250</b>	<b>0</b>	<b>271</b>	<b>0</b>	<b>0</b>	<b>252</b>	<b>56</b>	<b>1</b>	<b>309</b>	<b>0</b>	<b>0</b>	<b>99</b>	<b>61</b>	<b>0</b>	<b>160</b>
<b>Grand Total</b>	<b>130</b>	<b>789</b>	<b>0</b>	<b>919</b>	<b>0</b>	<b>0</b>	<b>776</b>	<b>357</b>	<b>1</b>	<b>1134</b>	<b>5</b>	<b>3</b>	<b>348</b>	<b>206</b>	<b>0</b>	<b>557</b>
% Approach	14.1%	85.9%	0.0%	0.0%	0.0%	0.0%	68.4%	31.5%	0.1%	0.0%	0.0%	0.0%	62.5%	37.0%	0.0%	0.0%
% Total	5.0%	30.2%	0.0%	35.2%	0.0%	0.0%	29.7%	13.7%	0.0%	43.4%	0.0%	0.0%	13.3%	7.9%	0.0%	21.3%
Lights	124	734	0	858	0	0	733	349	1	1083	0	0	334	195	0	529
% Lights	95.4%	93.0%	0.0%	93.4%	0.0%	0.0%	94.5%	97.8%	100.0%	95.8%	0.0%	0.0%	96.0%	94.7%	0.0%	95.0%
Trucks	0	1	0	1	0	0	1	0	0	1	0	0	0	0	0	0
% Trucks	0.0%	0.1%	0.0%	0.1%	0.0%	0.0%	0.1%	0.0%	0.0%	0.1%	0.0%	0.0%	0.0%	0.0%	0.0%	0.0%
Buses	6	54	0	60	0	0	42	8	0	50	0	0	14	11	0	25
% Buses	4.6%	6.8%	0.0%	0.0%	0.0%	0.0%	0.0%	2.2%	0.0%	0.0%	0.0%	0.0%	4.0%	5.3%	0.0%	0.0%
Pedestrians	0	0	0	0	0	0	0	0	0	0	5	2	0	0	0	0
% Pedestrians	0.0%	0.0%	0.0%	0.0%	0.0%	0.0%	0.0%	0.0%	0.0%	0.0%	100.0%	66.7%	0.0%	0.0%	0.0%	0.0%
Bicycles on Crosswalk	0	0	0	0	0	0	0	0	0	0	0	1	0	0	0	0
% Bicycles on Crosswalk	0.0%	0.0%	0.0%	0.0%	0.0%	0.0%	0.0%	0.0%	0.0%	0.0%	0.0%	33.3%	0.0%	0.0%	0.0%	0.0%

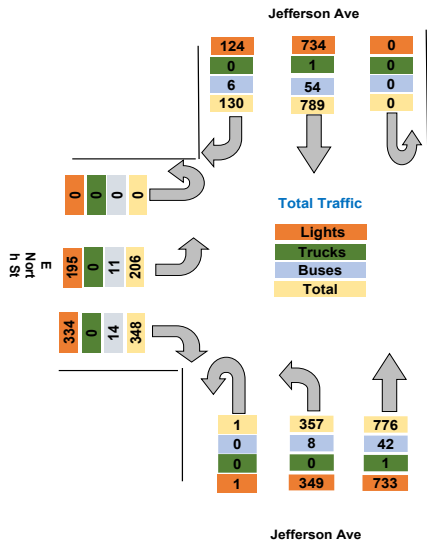

Turning Movement Data Plot

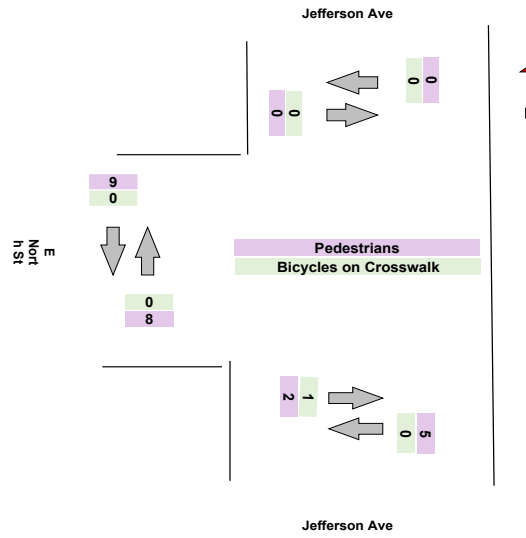

Turning Movement Peak Hour Data (AM)

7:30:00 AM

Leg Direction	Jefferson Ave Southbound						Jefferson Ave NorthBound						E North St Eastbound			
	Right	Thru	U-Turn	App Total	Peds CW	Peds CCW	Thru	Left	U-Turn	App Total	Peds CW	Peds CCW	Right	Left	U-Turn	App Total
7:30:00 AM	10	34	0	44	0	0	33	42	0	75	2	0	19	11	0	32
7:45:00 AM	25	52	0	77	0	0	42	54	0	96	0	0	15	17	0	32
8:00:00 AM	11	66	0	77	0	0	35	46	0	81	1	0	23	18	0	42
8:15:00 AM	4	41	0	45	0	0	39	15	0	54	0	0	14	9	0	23
<b>Grand Total</b>	<b>50</b>	<b>193</b>	<b>0</b>	<b>243</b>	<b>0</b>	<b>0</b>	<b>149</b>	<b>157</b>	<b>0</b>	<b>306</b>	<b>3</b>	<b>0</b>	<b>71</b>	<b>55</b>	<b>0</b>	<b>129</b>
% Approach	20.6%	79.4%	0.0%	0.0%	0.0%	0.0%	48.7%	51.3%	0.0%	0.0%	0.0%	0.0%	55.0%	42.6%	0.0%	0.0%
% Total	7.4%	28.5%	0.0%	35.8%	0.0%	0.0%	22.0%	23.2%	0.0%	45.1%	0.0%	0.0%	10.5%	8.1%	0.0%	19.0%
PHF	0.500	0.731	0.000	0.789	0.000	0.000	0.887	0.727	0.000	0.797	0.000	0.000	0.772	0.764	0.000	0.768
Lights	47	171	0	218	0	0	133	154	0	287	0	0	65	48	0	113
% Lights	94.0%	88.6%	0.0%	89.7%	0.0%	0.0%	89.3%	98.1%	0.0%	93.8%	0.0%	0.0%	91.5%	87.3%	0.0%	87.6%
Trucks	0	0	0	0	0	0	0	0	0	0	0	0	0	0	0	0
% Trucks	0.0%	0.0%	0.0%	0.0%	0.0%	0.0%	0.0%	0.0%	0.0%	0.0%	0.0%	0.0%	0.0%	0.0%	0.0%	0.0%
Buses	3	22	0	25	0	0	16	3	0	19	0	0	6	7	0	13
% Buses	6.0%	11.4%	0.0%	0.0%	0.0%	0.0%	10.7%	1.9%	0.0%	0.0%	0.0%	0.0%	8.5%	12.7%	0.0%	0.0%
Pedestrians	0	0	0	0	0	0	0	0	0	3	0	0	0	0	0	0
% Pedestrians	0.0%	0.0%	0.0%	0.0%	0.0%	0.0%	0.0%	0.0%	0.0%	100.0%	0.0%	0.0%	0.0%	0.0%	0.0%	0.0%
Bicycles on Crosswalk	0	0	0	0	0	0	0	0	0	0	0	0	0	0	0	0
% Bicycles on Crosswalk	0.0%	0.0%	0.0%	0.0%	0.0%	0.0%	0.0%	0.0%	0.0%	0.0%	0.0%	0.0%	0.0%	0.0%	0.0%	0.0%

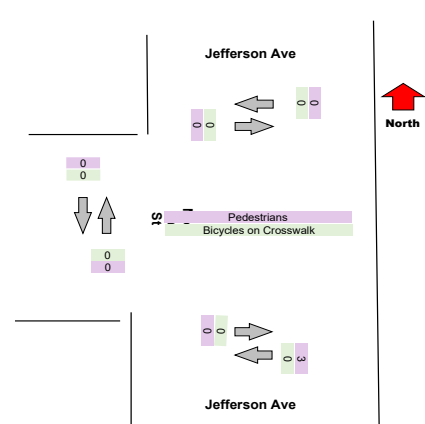
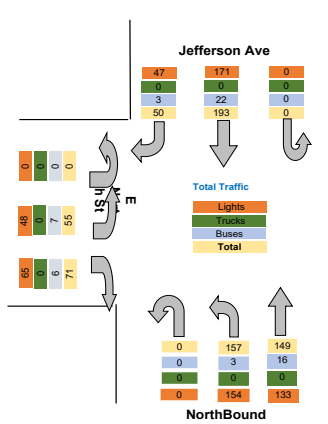

Turning Movement Peak Hour Data (PM)

4:15:00 PM

Leg Direction	Jefferson Ave Southbound						Jefferson Ave Northbound						E North St Eastbound			
	Right	Thru	U-Turn	App Total	Peds CW	Peds CCW	Thru	Left	U-Turn	App Total	Peds CW	Peds CCW	Right	Left	U-Turn	App Total
4:15:00 PM	2	69	0	71	0	0	68	10	0	78	0	1	34	19	0	53
4:30:00 PM	10	71	0	81	0	0	55	14	0	69	2	0	36	15	0	51
4:45:00 PM	2	58	0	60	0	0	70	5	0	75	0	0	31	21	0	52
5:00:00 PM	6	77	0	83	0	0	74	12	1	87	0	0	29	19	0	48
<b>Grand Total</b>	20	275	0	295	0	0	267	41	1	309	2	1	130	74	0	204
% Approach	6.8%	93.2%	0.0%	0.0%	0.0%	0.0%	86.4%	13.3%	0.3%	0.0%	0.0%	0.0%	63.7%	36.3%	0.0%	0.0%
% Total	2.5%	34.0%	0.0%	36.5%	0.0%	0.0%	33.0%	5.1%	0.1%	38.2%	0.0%	0.0%	16.1%	9.2%	0.0%	25.2%
PHF	0.500	0.893	0.000	0.889	0.000	0.000	0.902	0.732	0.250	0.888	0.000	0.000	0.903	0.881	0.000	0.962
Lights	17	264	0	281	0	0	257	39	1	297	0	0	127	71	0	198
% Lights	85.0%	96.0%	0.0%	95.3%	0.0%	0.0%	96.3%	95.1%	100.0%	96.1%	0.0%	0.0%	97.7%	95.9%	0.0%	97.1%
Trucks	0	0	0	0	0	0	0	0	0	0	0	0	0	0	0	0
% Trucks	0.0%	0.0%	0.0%	0.0%	0.0%	0.0%	0.0%	0.0%	0.0%	0.0%	0.0%	0.0%	0.0%	0.0%	0.0%	0.0%
Buses	3	11	0	14	0	0	10	2	0	12	0	0	3	0	0	6
% Buses	15.0%	4.0%	0.0%	0.0%	0.0%	0.0%	3.7%	4.9%	0.0%	0.0%	0.0%	0.0%	2.3%	4.1%	0.0%	0.0%
Pedestrians	0	0	0	0	0	0	0	0	0	0	2	1	0	0	0	0
% Pedestrians	0.0%	0.0%	0.0%	0.0%	0.0%	0.0%	0.0%	0.0%	0.0%	0.0%	100.0%	100.0%	0.0%	0.0%	0.0%	0.0%
Bicycles on Crosswalk	0	0	0	0	0	0	0	0	0	0	0	0	0	0	0	0
% Bicycles on Crosswalk	0.0%	0.0%	0.0%	0.0%	0.0%	0.0%	0.0%	0.0%	0.0%	0.0%	0.0%	0.0%	0.0%	0.0%	0.0%	0.0%

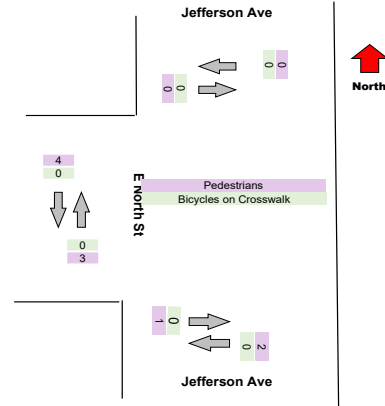
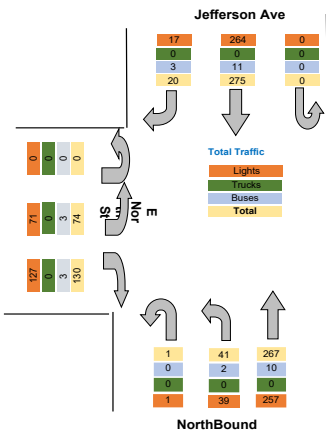

Intersection: Elm St Pine St  
 Location: Kennett Square, PA  
 Site: 01  
 Survey Date: Wednesday, 04-28-2021  
 GPS: 42.948550, -72.790034

Peds CW	Peds CCW	Total
0	0	53
1	0	88
1	0	141
0	0	109
0	0	132
0	0	151
0	0	205
0	0	597
0	0	200
0	0	122
0	0	322
0	1	220
0	1	202
0	0	201
1	0	187
1	2	810
2	3	218
2	3	183
1	0	166
1	1	173
6	7	740
8	9	2610
0.0%	0.0%	0.0%
0.0%	0.0%	0.0%
0	0	2470
0.0%	0.0%	94.6%
0	0	2
0.0%	0.0%	0.1%
0	0	135
0.0%	0.0%	5.2%
8	9	0
100.0%	100.0%	0.0%
0	0	0
0.0%	0.0%	0.0%

Intersection: Elm St Pine St  
 Location: Kennett Square, PA  
 Site: 01  
 Survey Date: Wednesday, 04-28-2021  
 GPS: 42.948550, -72.790034



Peds CW	Peds CCW	Total
0	0	<b>151</b>
0	0	<b>205</b>
0	0	<b>200</b>
0	0	<b>122</b>
0	0	<b>678</b>
0.0%	0.0%	
0.0%	0.0%	
0.000	0.000	<b>0.827</b>
0	0	<b>618</b>
0.0%	0.0%	<b>91.2%</b>
0	0	<b>0</b>
0.0%	0.0%	<b>0.0%</b>
0	0	<b>57</b>
0.0%	0.0%	<b>8.4%</b>
0	0	<b>0</b>
0.0%	0.0%	<b>0.0%</b>
0	0	<b>0</b>
0.0%	0.0%	<b>0.0%</b>

Intersection: Elm St Pine St  
 Location: Kennett Square, PA  
 Site: 01  
 Survey Date: Wednesday, 04-28-2021  
 GPS: 42.948550, -72.790034

Peds CW	Peds CCW	Total
0	1	<b>202</b>
0	0	<b>201</b>
1	0	<b>187</b>
2	3	<b>218</b>
3	4	<b>808</b>
0.0%	0.0%	
0.0%	0.0%	
0.000	0.000	<b>0.927</b>
0	0	<b>776</b>
0.0%	0.0%	<b>96.0%</b>
0	0	<b>0</b>
0.0%	0.0%	<b>0.0%</b>
0	0	<b>32</b>
0.0%	0.0%	<b>4.0%</b>
<b>3</b>	<b>4</b>	<b>0</b>
100.0%	100.0%	<b>0.0%</b>
<b>0</b>	<b>0</b>	<b>0</b>
0.0%	0.0%	<b>0.0%</b>



Intersection: Elm St Pine St  
 Location: Kennett Square, PA  
 Site: 01  
 Survey Date: Wednesday, 04-28-2021  
 GPS: 42.948550, -72.790034



Project	LaBella
Project Code	LaBella
Site Name	37
Legs and Movements	All Processed Legs & Movements
Bin Size	15 minutes
Survey Date	2021-11-04, Thursday
Location	37
Latitude and Longitude	42.902086, -78.853994

	Start	End	PHF
Forced Peak AM	2021/11/04 07:30:00	2021/11/04 08:30:00	0.25
Forced Peak PM	2021/11/04 16:30:00	2021/11/04 17:30:00	0.25
AM Peak	2021/11/04 07:30:00	2021/11/04 08:30:00	0.25
PM Peak	2021/11/04 16:15:00	2021/11/04 17:15:00	0.25

Turning Movement Data

Leg Direction	Jefferson Ave Southbound					Jefferson Ave Northbound					E North St Eastbound							
	Right	Thru	U-Turn	App Total	Peds CW	Peds CCW	Thru	Left	U-Turn	App Total	Peds CW	Peds CCW	Right	Left	U-Turn	App Total	Peds CW	
Start Time																		
6:30:00 AM	11	18	0	29	0	0	19	17	0	36	0	0	11	0	0	11	0	0
6:45:00 AM	9	17	0	26	0	0	25	25	0	50	0	0	8	4	0	12	1	0
<b>Hourly Total</b>	<b>20</b>	<b>35</b>	<b>0</b>	<b>55</b>	<b>0</b>	<b>0</b>	<b>44</b>	<b>42</b>	<b>0</b>	<b>86</b>	<b>0</b>	<b>0</b>	<b>19</b>	<b>4</b>	<b>0</b>	<b>23</b>	<b>1</b>	<b>0</b>
7:00:00 AM	5	18	0	23	0	0	24	26	0	50	0	0	8	3	0	11	0	0
7:15:00 AM	11	30	0	41	0	0	23	29	0	52	0	0	9	8	0	17	0	0
7:30:00 AM	11	45	0	56	0	0	39	52	0	91	1	0	16	10	0	27	0	0
7:45:00 AM	21	32	0	53	0	0	48	58	0	106	0	0	19	12	0	31	0	0
<b>Hourly Total</b>	<b>48</b>	<b>125</b>	<b>0</b>	<b>173</b>	<b>0</b>	<b>0</b>	<b>134</b>	<b>165</b>	<b>0</b>	<b>299</b>	<b>1</b>	<b>0</b>	<b>52</b>	<b>33</b>	<b>0</b>	<b>86</b>	<b>0</b>	<b>0</b>
8:00:00 AM	15	56	0	71	0	0	48	52	0	100	1	0	25	14	0	40	0	0
8:15:00 AM	8	45	0	53	0	0	39	20	0	59	0	0	13	9	0	22	0	0
<b>Hourly Total</b>	<b>23</b>	<b>101</b>	<b>0</b>	<b>124</b>	<b>0</b>	<b>0</b>	<b>87</b>	<b>72</b>	<b>0</b>	<b>159</b>	<b>1</b>	<b>0</b>	<b>38</b>	<b>23</b>	<b>0</b>	<b>62</b>	<b>0</b>	<b>0</b>
4:00:00 PM	4	76	0	80	0	0	54	17	0	71	0	0	49	17	0	66	2	0
4:15:00 PM	7	67	0	74	0	0	57	14	0	71	0	0	29	11	0	40	0	0
4:30:00 PM	5	60	0	65	0	0	71	5	0	76	0	0	40	16	0	56	2	0
4:45:00 PM	3	55	0	58	0	0	68	11	0	79	0	2	29	14	0	43	1	0
<b>Hourly Total</b>	<b>19</b>	<b>258</b>	<b>0</b>	<b>277</b>	<b>0</b>	<b>0</b>	<b>250</b>	<b>47</b>	<b>0</b>	<b>297</b>	<b>0</b>	<b>2</b>	<b>147</b>	<b>58</b>	<b>0</b>	<b>205</b>	<b>5</b>	<b>0</b>
5:00:00 PM	5	63	0	68	0	0	63	14	0	77	1	0	30	12	0	42	2	0
5:15:00 PM	5	60	0	65	0	0	55	12	0	67	0	0	27	10	0	37	0	0
5:30:00 PM	3	59	0	62	0	0	64	14	0	78	0	0	25	15	0	40	1	0
5:45:00 PM	3	50	0	53	0	0	63	4	0	67	0	0	18	17	0	35	0	0
<b>Hourly Total</b>	<b>16</b>	<b>232</b>	<b>0</b>	<b>248</b>	<b>0</b>	<b>0</b>	<b>245</b>	<b>44</b>	<b>0</b>	<b>289</b>	<b>1</b>	<b>0</b>	<b>100</b>	<b>54</b>	<b>0</b>	<b>154</b>	<b>3</b>	<b>0</b>
<b>Grand Total</b>	<b>126</b>	<b>751</b>	<b>0</b>	<b>877</b>	<b>0</b>	<b>0</b>	<b>760</b>	<b>370</b>	<b>0</b>	<b>1130</b>	<b>3</b>	<b>2</b>	<b>356</b>	<b>172</b>	<b>0</b>	<b>530</b>	<b>9</b>	<b>0</b>
% Approach	14.4%	85.6%	0.0%	0.0%	0.0%	0.0%	67.3%	32.7%	0.0%	0.0%	0.0%	0.0%	67.2%	32.5%	0.0%	0.0%	0.0%	0.0%
% Total	5.0%	29.6%	0.0%	34.6%	0.0%	0.0%	30.0%	14.6%	0.0%	44.5%	0.0%	0.0%	14.0%	6.8%	0.0%	20.9%	0.0%	0.0%
Lights	122	697	0	819	0	0	715	364	0	1079	0	0	340	167	0	507	0	0
% Lights	96.8%	92.8%	0.0%	93.4%	0.0%	0.0%	94.1%	98.4%	0.0%	95.5%	0.0%	0.0%	95.5%	97.1%	0.0%	95.7%	0.0%	0.0%
Trucks	0	0	0	0	0	0	0	0	0	0	0	0	0	0	0	0	0	0
% Trucks	0.0%	0.0%	0.0%	0.0%	0.0%	0.0%	0.0%	0.0%	0.0%	0.0%	0.0%	0.0%	0.0%	0.0%	0.0%	0.0%	0.0%	0.0%
Buses	4	52	0	56	0	0	45	5	0	50	0	0	16	5	0	21	0	0
% Buses	3.2%	6.9%	0.0%	0.0%	0.0%	0.0%	0.0%	1.4%	0.0%	0.0%	0.0%	0.0%	4.5%	2.9%	0.0%	0.0%	0.0%	0.0%
Pedestrians	0	0	0	0	0	0	0	0	0	0	3	2	0	0	0	0	9	0
% Pedestrians	0.0%	0.0%	0.0%	0.0%	0.0%	0.0%	0.0%	0.0%	0.0%	0.0%	100.0%	100.0%	0.0%	0.0%	0.0%	0.0%	100.0%	0.0%
Bicycles on Crosswalk	0	0	0	0	0	0	0	0	0	0	0	0	0	0	0	0	0	0
% Bicycles on Crosswalk	0.0%	0.0%	0.0%	0.0%	0.0%	0.0%	0.0%	0.0%	0.0%	0.0%	0.0%	0.0%	0.0%	0.0%	0.0%	0.0%	0.0%	0.0%

Turning Movement Data Plot

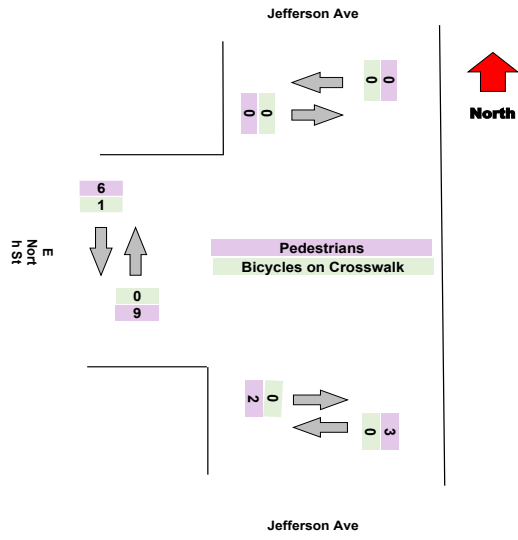
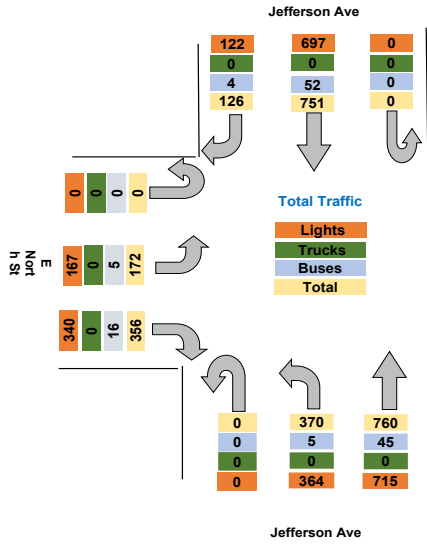

Turning Movement Peak Hour Data (AM)

7:30:00 AM

Leg Direction	Jefferson Ave Southbound						Jefferson Ave NorthBound						E North St Eastbound					
	Right	Thru	U-Turn	App Total	Peds CW	Peds CCW	Thru	Left	U-Turn	App Total	Peds CW	Peds CCW	Right	Left	U-Turn	App Total	Peds CW	
7:30:00 AM	0	0	0	0	0	0	0	0	0	0	0	0	0	0	0	0	0	0
7:45:00 AM	126	751	0	877	0	0	760	370	0	1130	3	2	356	172	0	530	9	0
8:00:00 AM	0.14367	0.85633	0	0	0	0	0.67257	0.32743	0	0	0	0	0.6717	0.32453	0	0	0	0
8:15:00 AM	0.04966	0.29602	0	0.34568	0	0	0.29957	0.14584	0	0.44541	0	0	0.14032	0.0678	0	0.20891	0	0
<b>Grand Total</b>	<b>126.193</b>	<b>752.152</b>	<b>0</b>	<b>877.346</b>	<b>0</b>	<b>0</b>	<b>760.972</b>	<b>370.473</b>	<b>0</b>	<b>1130.45</b>	<b>3</b>	<b>2</b>	<b>356.812</b>	<b>172.392</b>	<b>0</b>	<b>530.209</b>	<b>9</b>	<b>0</b>
% Approach	14.4%	85.7%	0.0%	0.0%	0.0%	0.0%	67.3%	32.8%	0.0%	0.0%	0.0%	0.0%	67.3%	32.5%	0.0%	0.0%	0.0%	0.0%
% Total	5.0%	29.6%	0.0%	34.6%	0.0%	0.0%	30.0%	14.6%	0.0%	44.6%	0.0%	0.0%	14.1%	6.8%	0.0%	20.9%	0.0%	0.0%
PHF	0.250	0.250	0.000	0.250	0.000	0.000	0.250	0.250	0.000	0.250	0.000	0.000	0.251	0.251	0.000	0.250	0.000	0.000
Lights	122	697	0	819	0	0	715	364	0	1079	0	0	340	167	0	507	0	0
% Lights	96.7%	92.7%	0.0%	93.3%	0.0%	0.0%	94.0%	98.3%	0.0%	95.4%	0.0%	0.0%	95.3%	96.9%	0.0%	95.6%	0.0%	0.0%
Trucks	0	0	0	0	0	0	0	0	0	0	0	0	0	0	0	0	0	0
% Trucks	0.0%	0.0%	0.0%	0.0%	0.0%	0.0%	0.0%	0.0%	0.0%	0.0%	0.0%	0.0%	0.0%	0.0%	0.0%	0.0%	0.0%	0.0%
Buses	4	52	0	56	0	0	45	5	0	50	0	0	16	5	0	21	0	0
% Buses	3.2%	6.9%	0.0%	0.0%	0.0%	0.0%	5.9%	1.3%	0.0%	0.0%	0.0%	0.0%	4.5%	2.9%	0.0%	0.0%	0.0%	0.0%
Pedestrians	0	0	0	0	0	0	0	0	0	3	2	0	0	0	0	0	0	9
% Pedestrians	0.0%	0.0%	0.0%	0.0%	0.0%	0.0%	0.0%	0.0%	0.0%	100.0%	100.0%	0.0%	0.0%	0.0%	0.0%	0.0%	0.0%	100.0%
Bicycles on Crosswalk	0	0	0	0	0	0	0	0	0	0	0	0	0	0	0	0	0	0
% Bicycles on Crosswalk	0.0%	0.0%	0.0%	0.0%	0.0%	0.0%	0.0%	0.0%	0.0%	0.0%	0.0%	0.0%	0.0%	0.0%	0.0%	0.0%	0.0%	0.0%

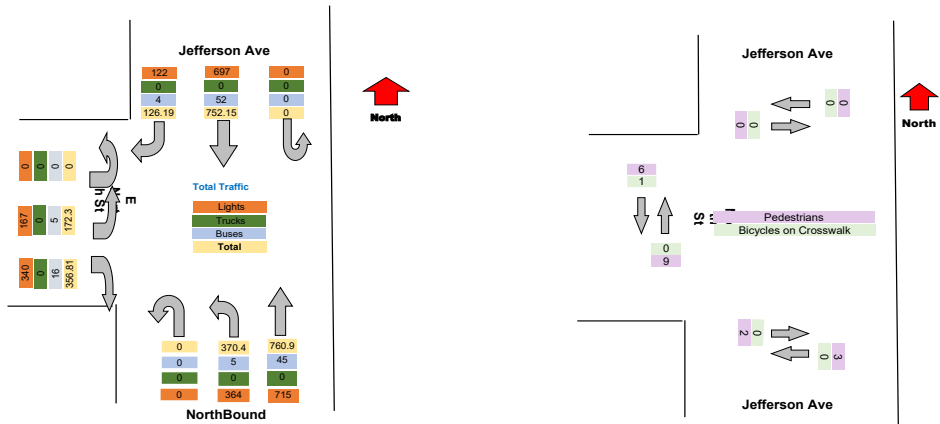

Turning Movement Peak Hour Data (PM)

4:15:00 PM

Leg Direction	Jefferson Ave Southbound						Jefferson Ave NorthBound						E North St Eastbound					
	Right	Thru	U-Turn	App Total	Peds CW	Peds CCW	Thru	Left	U-Turn	App Total	Peds CW	Peds CCW	Right	Left	U-Turn	App Total	Peds CW	
4:15:00 PM	0	0	0	0	0	0	0	0	0	0	0	0	0	0	0	0	0	
4:30:00 PM	126	751	0	877	0	0	760	370	0	1130	3	2	356	172	0	530	9	
4:45:00 PM	0.14367	0.85633	0	0	0	0	0.67257	0.32743	0	0	0	0	0.6717	0.32453	0	0	0	
5:00:00 PM	0.04966	0.29602	0	0.34568	0	0	0.29957	0.14584	0	0.44541	0	0	0.14032	0.0678	0	0.20891	0	
<b>Grand Total</b>	126.193	752.152	0	877.346	0	0	760.972	370.473	0	1130.45	3	2	356.812	172.392	0	530.209	9	
% Approach	14.4%	85.7%	0.0%	0.0%	0.0%	0.0%	67.3%	32.8%	0.0%	0.0%	0.0%	0.0%	67.3%	32.5%	0.0%	0.0%	0.0%	
% Total	5.0%	29.6%	0.0%	34.6%	0.0%	0.0%	30.0%	14.6%	0.0%	44.6%	0.0%	0.0%	14.1%	6.8%	0.0%	20.9%	0.0%	
PHF	0.250	0.250	0.000	0.250	0.000	0.000	0.250	0.250	0.000	0.250	0.000	0.000	0.251	0.251	0.000	0.250	0.000	
Lights	122	697	0	819	0	0	715	364	0	1079	0	0	340	167	0	507	0	
% Lights	96.7%	92.7%	0.0%	93.3%	0.0%	0.0%	94.0%	98.3%	0.0%	95.4%	0.0%	0.0%	95.3%	96.9%	0.0%	95.6%	0.0%	
Trucks	0	0	0	0	0	0	0	0	0	0	0	0	0	0	0	0	0	
% Trucks	0.0%	0.0%	0.0%	0.0%	0.0%	0.0%	0.0%	0.0%	0.0%	0.0%	0.0%	0.0%	0.0%	0.0%	0.0%	0.0%	0.0%	
Buses	4	52	0	56	0	0	45	5	0	50	0	0	16	5	0	21	0	
% Buses	3.2%	6.9%	0.0%	0.0%	0.0%	0.0%	5.9%	1.3%	0.0%	0.0%	0.0%	0.0%	4.5%	2.9%	0.0%	0.0%	0.0%	
Pedestrians	0	0	0	0	0	0	0	0	0	3	2	0	0	0	0	9		
% Pedestrians	0.0%	0.0%	0.0%	0.0%	0.0%	0.0%	0.0%	0.0%	0.0%	0.0%	100.0%	100.0%	0.0%	0.0%	0.0%	0.0%	100.0%	
Bicycles on Crosswalk	0	0	0	0	0	0	0	0	0	0	0	0	0	0	0	0	0	
% Bicycles on Crosswalk	0.0%	0.0%	0.0%	0.0%	0.0%	0.0%	0.0%	0.0%	0.0%	0.0%	0.0%	0.0%	0.0%	0.0%	0.0%	0.0%	0.0%	

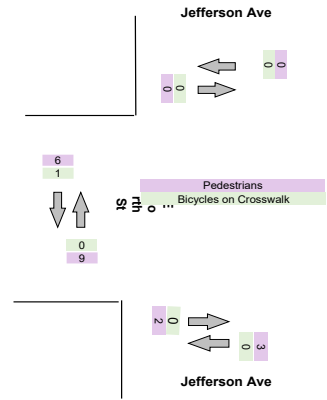
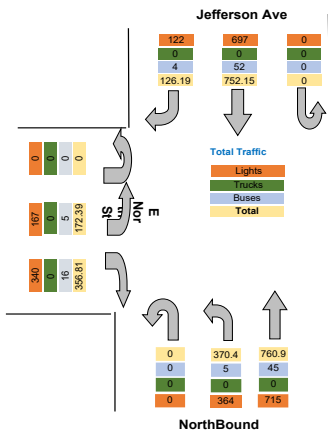

Intersection: Elm St Pine St  
 Location: Kennett Square, PA  
 Site: 01  
 Survey Date: Wednesday, 04-28-2021  
 GPS: 42.948550, -72.790034



Peds CCW	Total
0	76
0	88
0	164
0	84
0	110
0	174
0	190
0	558
0	211
0	134
0	345
1	217
0	185
1	197
1	180
3	779
1	187
0	169
1	180
2	155
4	691
7	2537
0.0%	0.0%
0.0%	0.0%
0	2405
0.0%	94.8%
0	0
0.0%	0.0%
0	127
0.0%	5.0%
6	0
85.7%	0.0%
1	0
14.3%	0.0%

Intersection: Elm St Pine St  
 Location: Kennett Square, PA  
 Site: 01  
 Survey Date: Wednesday, 04-28-2021  
 GPS: 42.948550, -72.790034



Peds CCW	Total
0	0
7	2537
0	0
0	0
7	2537
0.0%	
0.0%	
0.000	0.250
0	2405
0.0%	94.8%
0	0
0.0%	0.0%
0	127
0.0%	5.0%
6	0
85.7%	0.0%
1	0
14.3%	0.0%

Intersection: Elm St Pine St  
 Location: Kennett Square, PA  
 Site: 01  
 Survey Date: Wednesday, 04-28-2021  
 GPS: 42.948550, -72.790034



Peds CCW	Total
0	0
7	2537
0	0
0	0
7	2537
0.0%	
0.0%	
0.000	0.250
0	2405
0.0%	94.8%
0	0
0.0%	0.0%
0	127
0.0%	5.0%
6	0
85.7%	0.0%
1	0
14.3%	0.0%

Project : VBH Malta NY  
 Site : Site 4  
 Location : 42.948550, -73.790036

TSTData.com

Survey Date : 2021-04-28, Wednesday

Project	LaBella
Project Code	LaBella
Site Name	38
Legs and Movements	All Processed Legs & Move
Bin Size	15 minutes
Survey Date	2021-11-02, Tuesday
Location	38
Latitude and Longitude	42.900219, -78.853976

	Start	End	PHF
Forced Peak AM	2021/11/02 07:30:00	2021/11/02 08:30:00	0.94
Forced Peak PM	2021/11/02 16:30:00	2021/11/02 17:30:00	0.9
AM Peak	2021/11/02 07:30:00	2021/11/02 08:30:00	0.94
PM Peak	2021/11/02 16:15:00	2021/11/02 17:15:00	0.88

### Turning Movement Data

Leg Direction	Jefferson Ave										High St				Jefferson Ave										High St				Total
	Southbound					Westbound					Westbound		Northbound		Northbound					Eastbound									
	Right	Thru	Left	U-Turn	App Total	Peds CV	Peds CCV	Right	Thru	Left	U-Turn	App Total	Peds CV	Peds CCV	Right	Thru	Left	U-Turn	App Total	Peds CV	Peds CCV	Right	Thru	Left	U-Turn	App Total	Peds CV	Peds CCV	
6:30:00 AM	0	12	0	0	12	0	0	1	12	1	0	14	0	0	0	26	19	0	45	0	0	8	3	2	0	13	0	0	84
6:45:00 AM	4	22	1	0	27	0	0	3	25	0	0	28	0	1	0	38	27	0	65	0	3	5	3	1	0	12	0	1	133
Hourly Total	4	34	1	0	39	0	0	4	37	1	0	42	0	1	0	64	46	0	111	0	3	16	6	3	0	25	0	1	217
7:00:00 AM	0	25	3	0	28	0	1	2	8	1	0	10	1	0	1	24	19	0	45	1	0	17	10	1	0	28	0	1	111
7:15:00 AM	4	21	4	0	29	0	1	2	8	1	0	12	0	2	1	29	32	0	64	0	0	6	7	1	0	14	0	0	119
7:30:00 AM	3	24	7	0	34	0	0	3	17	0	0	20	0	0	1	46	36	0	83	0	0	14	9	1	0	24	0	0	161
7:45:00 AM	2	31	3	0	36	0	0	6	13	2	0	21	0	0	2	41	36	0	79	0	0	16	8	2	0	26	2	0	162
Hourly Total	9	101	17	0	127	0	2	13	44	4	0	61	1	2	5	140	123	0	271	1	0	53	34	5	0	92	2	1	553
8:00:00 AM	4	38	2	0	44	0	0	2	5	2	0	9	1	0	1	50	28	0	80	0	0	8	5	2	0	16	0	0	148
8:15:00 AM	3	37	3	0	43	0	0	4	9	2	0	15	0	0	1	35	31	0	67	0	0	8	5	0	0	13	0	0	138
Hourly Total	7	75	5	0	87	0	0	6	14	4	0	24	1	0	2	85	59	0	147	0	0	16	10	2	0	28	0	0	286
4:00:00 PM	4	80	9	0	93	0	0	5	9	3	0	17	2	2	4	58	12	0	74	0	0	39	11	3	0	53	0	0	237
4:15:00 PM	2	83	3	0	88	1	0	2	10	3	0	15	0	0	7	49	8	0	64	0	0	29	8	4	0	41	0	1	208
4:30:00 PM	2	101	11	0	114	1	0	4	14	6	0	26	1	2	6	54	9	0	69	1	0	30	11	11	0	52	0	0	261
4:45:00 PM	3	78	1	0	82	0	0	4	13	4	0	21	0	0	1	59	18	0	78	0	2	18	14	3	0	35	0	3	216
Hourly Total	11	342	24	0	377	2	0	15	48	18	0	79	3	4	18	220	47	0	285	1	2	116	44	21	0	181	0	4	922
5:00:00 PM	2	84	5	0	91	0	0	7	12	5	0	24	0	1	8	76	19	0	103	2	0	37	12	6	0	55	1	0	273
5:15:00 PM	2	93	3	0	98	0	0	8	13	2	0	23	4	0	6	57	12	0	75	1	1	18	10	5	0	33	0	0	229
5:30:00 PM	1	58	4	0	63	0	0	6	10	4	0	20	1	4	2	56	3	0	61	0	0	21	6	0	0	27	0	0	171
5:45:00 PM	2	68	1	0	71	0	0	2	12	5	0	19	0	0	8	56	9	0	73	0	0	13	10	0	0	23	0	2	186
Hourly Total	7	303	13	0	323	0	0	23	47	16	0	86	5	5	24	245	43	0	312	3	1	89	38	11	0	138	1	2	659
Grand Total	38	855	60	0	953	2	2	61	188	43	0	294	10	12	49	754	318	0	1128	5	6	290	132	42	0	464	3	8	2837
% Approach	4.0%	89.7%	6.3%	0.0%	0.0%	0.0%	0.0%	20.7%	63.9%	14.6%	0.0%	0.0%	0.0%	0.0%	4.4%	67.0%	28.2%	0.0%	0.0%	0.0%	0.0%	62.5%	28.4%	9.1%	0.0%	0.0%	0.0%	0.0%	0.0%
% Total	1.3%	30.1%	2.1%	0.0%	33.6%	0.0%	0.0%	2.2%	6.6%	1.5%	0.0%	10.4%	0.0%	0.0%	1.7%	26.6%	11.2%	0.0%	39.7%	0.0%	0.0%	10.2%	4.7%	1.5%	0.0%	16.4%	0.0%	0.0%	0.0%
Lights	38	841	59	0	938	0	0	60	188	43	0	291	0	0	49	739	314	0	1102	0	0	286	131	40	0	457	0	0	2788
% Lights	100.0%	98.4%	98.3%	0.0%	98.4%	0.0%	0.0%	98.4%	100.0%	100.0%	0.0%	99.0%	0.0%	0.0%	100.0%	98.0%	98.7%	0.0%	97.9%	0.0%	0.0%	98.6%	99.2%	95.2%	0.0%	98.5%	0.0%	0.0%	98.3%
Trucks	0	1	0	0	1	0	0	0	0	0	0	0	0	0	0	0	0	0	0	0	0	1	0	0	0	1	0	0	2
% Trucks	0.0%	0.1%	0.0%	0.0%	0.1%	0.0%	0.0%	0.0%	0.0%	0.0%	0.0%	0.0%	0.0%	0.0%	0.0%	0.0%	0.0%	0.0%	0.0%	0.0%	0.0%	0.3%	0.0%	0.0%	0.0%	0.2%	0.0%	0.0%	0.1%
Buses	0	12	1	0	13	0	0	1	0	0	0	1	0	0	0	15	4	0	19	0	0	2	1	2	0	5	0	0	38
% Buses	0.0%	1.4%	1.7%	0.0%	0.0%	0.0%	0.0%	0.0%	0.0%	0.0%	0.0%	0.0%	0.0%	0.0%	0.0%	2.0%	1.3%	0.0%	0.0%	0.0%	0.0%	0.7%	0.8%	4.8%	0.0%	0.0%	0.0%	0.0%	1.3%
Pedestrians	0	0	0	0	0	2	2	0	0	0	0	0	10	9	0	0	0	0	0	5	6	0	0	0	0	0	3	7	0
% Pedestrians	0.0%	0.0%	0.0%	0.0%	0.0%	100.0%	100.0%	0.0%	0.0%	0.0%	0.0%	0.0%	100.0%	75.0%	0.0%	0.0%	0.0%	0.0%	0.0%	100.0%	100.0%	0.0%	0.0%	0.0%	0.0%	0.0%	100.0%	87.5%	0.0%
Bicycles on Crosswalk	0	0	0	0	0	0	0	0	0	0	0	0	0	3	0	0	0	0	0	0	0	0	0	0	0	0	0	1	0
% Bicycles on Crosswalk	0.0%	0.0%	0.0%	0.0%	0.0%	0.0%	0.0%	0.0%	0.0%	0.0%	0.0%	0.0%	0.0%	25.0%	0.0%	0.0%	0.0%	0.0%	0.0%	0.0%	0.0%	0.0%	0.0%	0.0%	0.0%	0.0%	0.0%	12.5%	0.0%



Project : VBH Malta NY  
 Site : Site 4  
 Location : 42.948550, -73.790036  
 Survey Date : 2021-04-28, Wednesday

### Turning Movement Data Plot

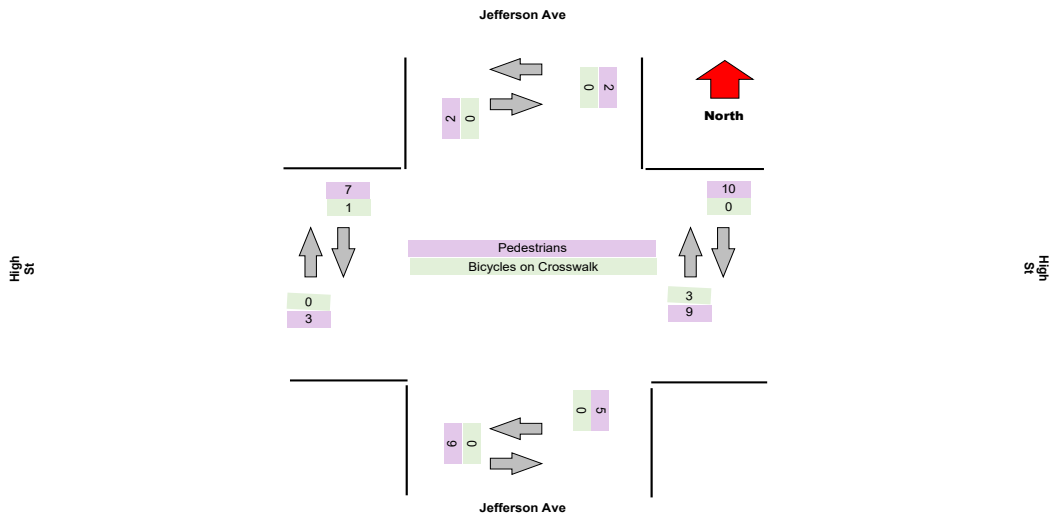
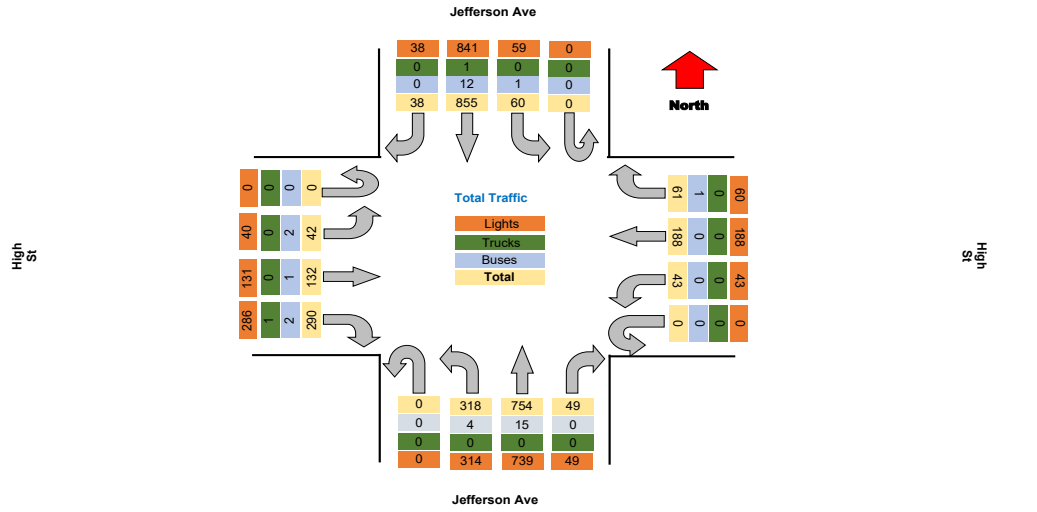

### Turning Movement Peak Hour Data (AM)

7:30:00 AM

Leg Direction	Jefferson Ave						High St						Jefferson Ave						High St						Total				
	Southbound			Northbound			Westbound			Eastbound			Northbound			Eastbound													
Start Time	Right	Thru	Left	U-Turn	App Total	Peds CW	Peds CCW	Right	Thru	Left	U-Turn	App Total	Peds CW	Peds CCW	Right	Thru	Left	U-Turn	App Total	Peds CW	Peds CCW	Right	Thru	Left	U-Turn	App Total	Peds CW	Peds CCW	
7:30:00 AM	3	24	7	0	34	0	0	3	17	0	0	20	0	0	1	46	36	0	83	0	0	14	9	1	0	24	0	0	
7:45:00 AM	2	31	3	0	36	0	0	6	13	2	0	21	0	0	2	41	36	0	79	0	0	16	8	2	0	26	2	0	
8:00:00 AM	4	38	2	0	44	0	0	2	5	2	0	9	1	0	1	50	28	0	80	0	0	8	5	2	0	15	0	0	
8:15:00 AM	3	37	3	0	43	0	0	4	9	2	0	15	0	0	1	35	31	0	67	0	0	8	5	0	0	13	0	0	
<b>Grand Total</b>	<b>12</b>	<b>100</b>	<b>15</b>	<b>0</b>	<b>127</b>	<b>0</b>	<b>0</b>	<b>15</b>	<b>44</b>	<b>6</b>	<b>0</b>	<b>65</b>	<b>1</b>	<b>0</b>	<b>5</b>	<b>172</b>	<b>131</b>	<b>0</b>	<b>308</b>	<b>0</b>	<b>0</b>	<b>46</b>	<b>27</b>	<b>5</b>	<b>0</b>	<b>78</b>	<b>2</b>	<b>0</b>	
% Approach	7.6%	82.8%	9.6%	0.0%	0.0%	0.0%	0.0%	23.1%	67.7%	9.2%	0.0%	0.0%	0.0%	0.0%	1.6%	95.7%	42.4%	0.0%	0.0%	0.0%	0.0%	59.0%	34.6%	6.4%	0.0%	0.0%	0.0%	0.0%	
% Total	2.0%	21.3%	2.5%	0.0%	25.8%	0.0%	0.0%	2.5%	7.2%	1.0%	0.0%	10.7%	0.0%	0.0%	0.8%	28.2%	21.5%	0.0%	50.7%	0.0%	0.0%	7.6%	4.4%	0.8%	0.0%	12.8%	0.0%	0.0%	
PHF	0.750	0.855	0.536	0.000	0.892	0.000	0.000	0.625	0.647	0.750	0.000	0.774	0.000	0.000	0.625	0.860	0.910	0.000	0.831	0.000	0.000	0.719	0.750	0.625	0.000	0.750	0.000	0.000	
Lights	12	127	15	0	154	0	0	14	44	6	0	64	0	0	5	169	131	0	305	0	0	44	26	5	0	75	0	0	
% Lights	100.0%	97.7%	100.0%	0.0%	98.1%	0.0%	0.0%	83.3%	100.0%	100.0%	0.0%	98.5%	0.0%	0.0%	100.0%	98.3%	100.0%	0.0%	98.7%	0.0%	0.0%	95.7%	96.3%	100.0%	0.0%	96.2%	0.0%	0.0%	
Trucks	0	0	0	0	0	0	0	0	0	0	0	0	0	0	0	0	0	0	0	0	0	0	0	0	0	0	0	0	
% Trucks	0.0%	0.0%	0.0%	0.0%	0.0%	0.0%	0.0%	0.0%	0.0%	0.0%	0.0%	0.0%	0.0%	0.0%	0.0%	0.0%	0.0%	0.0%	0.0%	0.0%	0.0%	0.0%	0.0%	0.0%	0.0%	0.0%	0.0%	0.0%	
Buses	0	3	0	0	3	0	0	1	0	0	0	1	0	0	0	3	0	0	3	0	0	2	1	0	0	3	0	0	
% Buses	0.0%	2.3%	0.0%	0.0%	0.0%	0.0%	0.0%	6.7%	0.0%	0.0%	0.0%	0.0%	0.0%	0.0%	0.0%	1.7%	0.0%	0.0%	0.0%	0.0%	0.0%	4.3%	3.7%	0.0%	0.0%	0.0%	0.0%	1.6%	
Pedestrians	0	0	0	0	0	0	0	0	0	0	0	1	0	0	0	0	0	0	0	0	0	0	0	0	0	0	2	0	
% Pedestrians	0.0%	0.0%	0.0%	0.0%	0.0%	0.0%	0.0%	0.0%	0.0%	0.0%	0.0%	0.0%	100.0%	0.0%	0.0%	0.0%	0.0%	0.0%	0.0%	0.0%	0.0%	0.0%	0.0%	0.0%	0.0%	0.0%	0.0%	100.0%	0.0%
Bicycles on Crosswalk	0	0	0	0	0	0	0	0	0	0	0	0	0	0	0	0	0	0	0	0	0	0	0	0	0	0	0	0	
% Bicycles on Crosswalk	0.0%	0.0%	0.0%	0.0%	0.0%	0.0%	0.0%	0.0%	0.0%	0.0%	0.0%	0.0%	0.0%	0.0%	0.0%	0.0%	0.0%	0.0%	0.0%	0.0%	0.0%	0.0%	0.0%	0.0%	0.0%	0.0%	0.0%	0.0%	

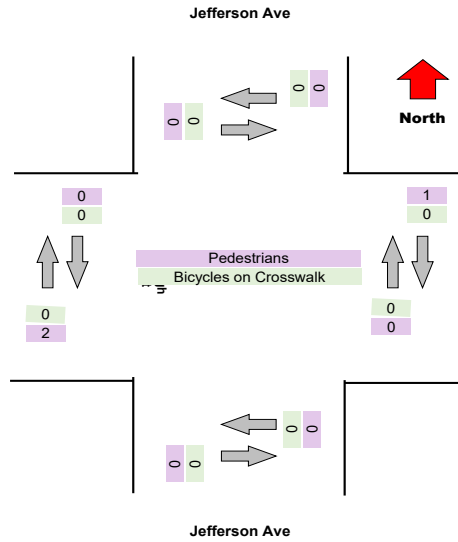
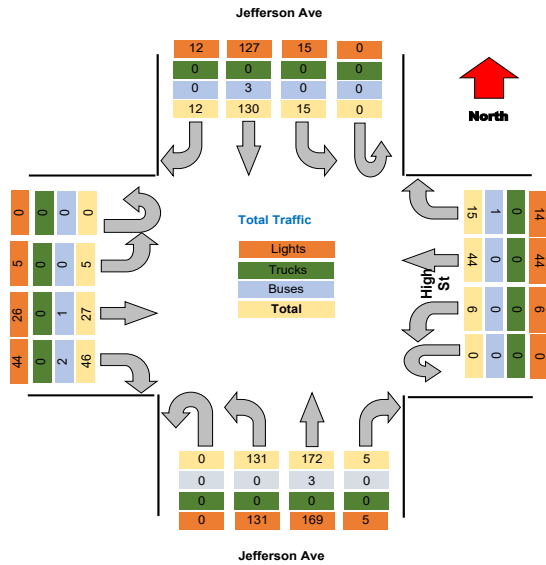

**Turning Movement Peak Hour Data (PM)**

4:15:00 PM

Leg Direction	Jefferson Ave										High St				Jefferson Ave										High St				Total
	Southbound					Westbound					Northbound				Eastbound														
	Right	Thru	Left	U-Turn	App Total	Peds CW	Peds CCW	Right	Thru	Left	U-Turn	App Total	Peds CW	Peds CCW	Right	Thru	Left	U-Turn	App Total	Peds CW	Peds CCW	Right	Thru	Left	U-Turn	App Total	Peds CW	Peds CCW	
4:15:00 PM	2	83	3	0	88	1	0	2	10	3	0	15	0	0	7	49	8	0	64	0	0	29	8	4	0	41	0	1	208
4:30:00 PM	2	101	11	0	114	1	0	4	14	8	0	26	1	2	6	54	9	0	69	1	0	30	11	11	0	52	0	0	261
4:45:00 PM	3	78	1	0	82	0	0	4	13	4	0	21	0	0	1	59	18	0	78	0	2	18	14	3	0	35	0	3	216
5:00:00 PM	2	84	5	0	91	0	0	7	12	5	0	24	0	1	8	78	19	0	103	2	0	37	12	6	0	55	1	0	273
<b>Grand Total</b>	<b>9</b>	<b>346</b>	<b>20</b>	<b>0</b>	<b>375</b>	<b>2</b>	<b>0</b>	<b>17</b>	<b>49</b>	<b>20</b>	<b>0</b>	<b>86</b>	<b>1</b>	<b>2</b>	<b>22</b>	<b>238</b>	<b>54</b>	<b>0</b>	<b>314</b>	<b>3</b>	<b>2</b>	<b>114</b>	<b>45</b>	<b>24</b>	<b>0</b>	<b>183</b>	<b>1</b>	<b>4</b>	<b>958</b>
% Approach	2.4%	92.3%	5.3%	0.0%	0.0%	0.0%	0.0%	19.8%	57.0%	23.3%	0.0%	0.0%	0.0%	0.0%	7.0%	75.8%	17.2%	0.0%	0.0%	0.0%	0.0%	62.3%	24.6%	13.1%	0.0%	0.0%	0.0%	0.0%	0.0%
% Total	0.9%	36.1%	2.1%	0.0%	38.1%	0.0%	0.0%	1.8%	5.1%	2.1%	0.0%	9.0%	0.0%	0.0%	2.3%	24.8%	5.6%	0.0%	32.8%	0.0%	0.0%	11.9%	4.7%	2.5%	0.0%	19.1%	0.0%	0.0%	0.0%
PHF	0.750	0.856	0.455	0.000	0.822	0.000	0.000	0.607	0.875	0.625	0.000	0.827	0.000	0.000	0.688	0.783	0.711	0.000	0.762	0.000	0.000	0.770	0.804	0.545	0.000	0.832	0.000	0.000	0.877
Lights	9	340	20	0	369	0	0	17	49	20	0	86	0	0	22	233	53	0	308	0	0	113	45	23	0	181	0	0	944
% Lights	100.0%	98.3%	100.0%	0.0%	98.4%	0.0%	0.0%	100.0%	100.0%	100.0%	0.0%	100.0%	0.0%	0.0%	100.0%	97.0%	98.1%	0.0%	98.1%	0.0%	0.0%	99.1%	100.0%	95.8%	0.0%	98.9%	0.0%	0.0%	98.6%
Trucks	0	1	0	0	1	0	0	0	0	0	0	0	0	0	0	0	0	0	0	0	0	0	0	0	0	0	0	0	1
% Trucks	0.0%	0.3%	0.0%	0.0%	0.3%	0.0%	0.0%	0.0%	0.0%	0.0%	0.0%	0.0%	0.0%	0.0%	0.0%	0.0%	0.0%	0.0%	0.0%	0.0%	0.0%	0.0%	0.0%	0.0%	0.0%	0.0%	0.0%	0.0%	0.1%
Buses	0	4	0	0	4	0	0	0	0	0	0	0	0	0	0	5	1	0	6	0	0	0	0	1	0	1	0	11	
% Buses	0.0%	1.2%	0.0%	0.0%	0.0%	0.0%	0.0%	0.0%	0.0%	0.0%	0.0%	0.0%	0.0%	0.0%	0.0%	2.1%	1.9%	0.0%	0.0%	0.0%	0.0%	0.0%	0.0%	4.2%	0.0%	0.0%	0.0%	1.1%	
Pedestrians	0	0	0	0	0	2	0	0	0	0	1	3	0	0	0	0	0	0	0	3	2	0	0	0	0	0	1	3	0
% Pedestrians	0.0%	0.0%	0.0%	0.0%	0.0%	100.0%	0.0%	0.0%	0.0%	0.0%	0.0%	100.0%	100.0%	0.0%	0.0%	0.0%	0.0%	0.0%	0.0%	0.0%	100.0%	100.0%	0.0%	0.0%	0.0%	0.0%	100.0%	75.0%	0.0%
Bicycles on Crosswalk	0	0	0	0	0	0	0	0	0	0	0	0	0	0	0	0	0	0	0	0	0	0	0	0	0	0	0	1	0
% Bicycles on Crosswalk	0.0%	0.0%	0.0%	0.0%	0.0%	0.0%	0.0%	0.0%	0.0%	0.0%	0.0%	0.0%	0.0%	0.0%	0.0%	0.0%	0.0%	0.0%	0.0%	0.0%	0.0%	0.0%	0.0%	0.0%	0.0%	0.0%	0.0%	25.0%	0.0%

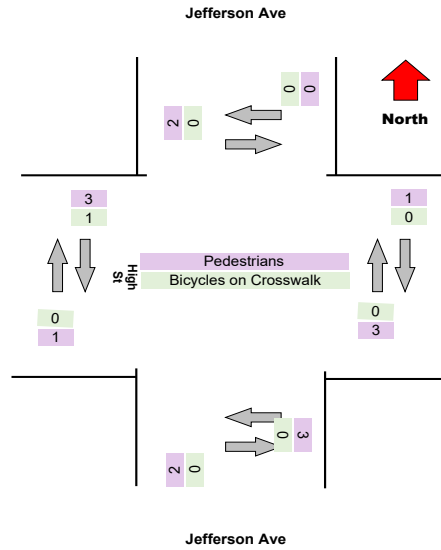
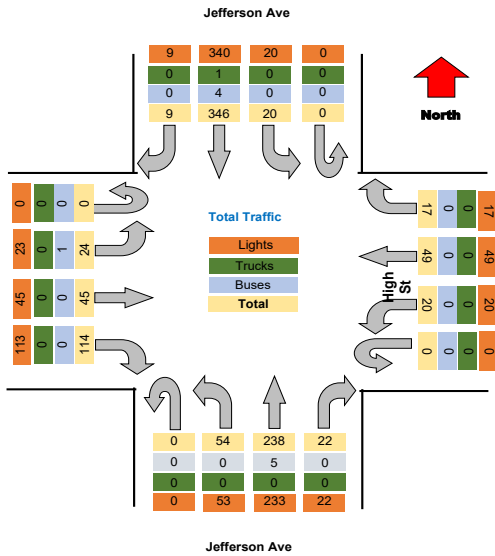



Project : VBH Malta NY  
 Site : Site 4  
 Location : 42.948550, -73.790036  
 Survey Date : 2021-04-28, Wednesday

### Turning Movement Data Plot

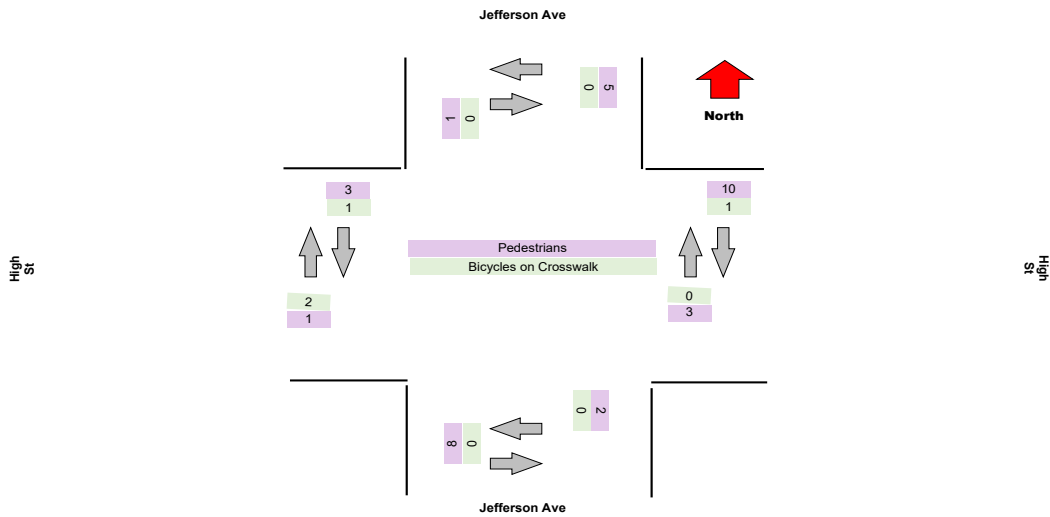
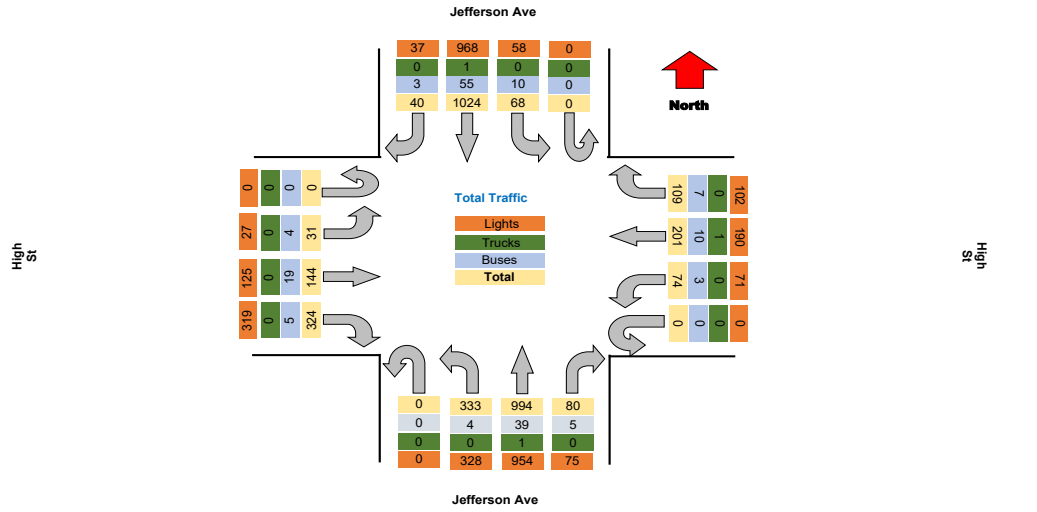

Project : VBH Malta NY  
Site : Site 4  
Location : 42.948550, -73.790036  
Survey Date : 2021-04-28, Wednesday

TSTData.com

**Turning Movement Peak Hour Data (AM)**

7:30:00 AM

Leg Direction	Jefferson Ave								High St								Jefferson Ave								High St								Total
	Southbound				Northbound				Westbound				Eastbound				Northbound				Eastbound												
Start Time	Right	Thru	Left	U-Turn	App Total	Peds CW	Peds CCW	Right	Thru	Left	U-Turn	App Total	Peds CW	Peds CCW	Right	Thru	Left	U-Turn	App Total	Peds CW	Peds CCW	Right	Thru	Left	U-Turn	App Total	Peds CW	Peds CCW					
7:30:00 AM	2	45	6	0	53	0	0	6	17	3	0	26	0	0	5	67	36	0	108	0	0	19	8	0	0	27	0	0	214				
7:45:00 AM	5	59	1	0	65	1	0	13	19	5	0	37	0	0	11	83	50	0	144	0	2	19	10	1	0	30	0	1	276				
8:00:00 AM	4	79	6	0	89	0	0	9	13	4	0	26	1	0	7	69	26	0	103	0	1	18	10	1	0	29	0	0	247				
8:15:00 AM	3	48	5	0	56	0	0	3	17	6	0	26	0	0	5	51	37	0	93	0	0	20	4	1	0	25	1	0	200				
<b>Grand Total</b>	<b>14</b>	<b>231</b>	<b>18</b>	<b>0</b>	<b>263</b>	<b>1</b>	<b>0</b>	<b>31</b>	<b>66</b>	<b>18</b>	<b>0</b>	<b>115</b>	<b>1</b>	<b>0</b>	<b>28</b>	<b>270</b>	<b>149</b>	<b>0</b>	<b>448</b>	<b>0</b>	<b>3</b>	<b>78</b>	<b>32</b>	<b>3</b>	<b>0</b>	<b>111</b>	<b>1</b>	<b>1</b>	<b>937</b>				
<b>% Approach</b>	5.3%	87.8%	6.8%	0.0%	0.0%	0.0%	0.0%	27.0%	57.4%	15.7%	0.0%	0.0%	0.0%	0.0%	6.3%	60.3%	33.3%	0.0%	0.0%	0.0%	0.0%	68.5%	26.8%	2.7%	0.0%	0.0%	0.0%	0.0%	0.0%				
<b>% Total</b>	1.5%	24.7%	1.9%	0.0%	28.1%	0.0%	0.0%	3.3%	7.0%	1.9%	0.0%	12.3%	0.0%	0.0%	3.0%	28.8%	15.9%	0.0%	47.8%	0.0%	0.0%	8.1%	3.4%	0.3%	0.0%	11.8%	0.0%	0.0%	6.8%				
<b>PHF</b>	0.700	0.731	0.750	0.000	0.739	0.000	0.000	0.596	0.868	0.750	0.000	0.777	0.000	0.000	0.636	0.813	0.745	0.000	0.778	0.000	0.000	0.950	0.800	0.750	0.000	0.925	0.000	0.000	0.849				
<b>Lights</b>	13	208	14	0	235	0	0	29	64	16	0	109	0	0	25	255	148	0	428	0	0	74	26	1	0	101	0	0	873				
<b>% Lights</b>	82.9%	90.0%	77.8%	0.0%	89.4%	0.0%	0.0%	83.5%	97.0%	88.9%	0.0%	94.8%	0.0%	0.0%	89.3%	94.4%	99.3%	0.0%	95.5%	0.0%	0.0%	97.4%	81.3%	33.3%	0.0%	91.0%	0.0%	0.0%	83.2%				
<b>Trucks</b>	0	0	0	0	0	0	0	0	1	0	0	1	0	0	0	0	0	0	0	0	0	0	0	0	0	0	0	0	1				
<b>% Trucks</b>	0.0%	0.0%	0.0%	0.0%	0.0%	0.0%	0.0%	0.0%	1.5%	0.0%	0.0%	0.9%	0.0%	0.0%	0.0%	0.0%	0.0%	0.0%	0.0%	0.0%	0.0%	0.0%	0.0%	0.0%	0.0%	0.0%	0.0%	0.0%	0.1%				
<b>Buses</b>	1	23	4	0	28	0	0	2	1	2	0	5	0	0	3	15	1	0	19	0	0	2	6	2	0	10	0	0	62				
<b>% Buses</b>	7.1%	10.0%	22.2%	0.0%	0.0%	0.0%	0.0%	6.5%	1.5%	11.1%	0.0%	0.0%	0.0%	0.0%	10.7%	5.8%	0.7%	0.0%	0.0%	0.0%	0.0%	2.6%	18.8%	66.7%	0.0%	0.0%	0.0%	0.0%	6.8%				
<b>Pedestrians</b>	0	0	0	0	0	1	0	0	0	0	0	1	0	0	0	0	0	0	0	0	3	0	0	0	0	0	1	1	0				
<b>% Pedestrians</b>	0.0%	0.0%	0.0%	0.0%	0.0%	100.0%	0.0%	0.0%	0.0%	0.0%	0.0%	0.0%	100.0%	0.0%	0.0%	0.0%	0.0%	0.0%	0.0%	0.0%	100.0%	0.0%	0.0%	0.0%	0.0%	0.0%	100.0%	100.0%	0.0%				
<b>Bicycles on Crosswalk</b>	0	0	0	0	0	0	0	0	0	0	0	0	0	0	0	0	0	0	0	0	0	0	0	0	0	0	0	0	0				
<b>% Bicycles on Crosswalk</b>	0.0%	0.0%	0.0%	0.0%	0.0%	0.0%	0.0%	0.0%	0.0%	0.0%	0.0%	0.0%	0.0%	0.0%	0.0%	0.0%	0.0%	0.0%	0.0%	0.0%	0.0%	0.0%	0.0%	0.0%	0.0%	0.0%	0.0%	0.0%	0.0%				

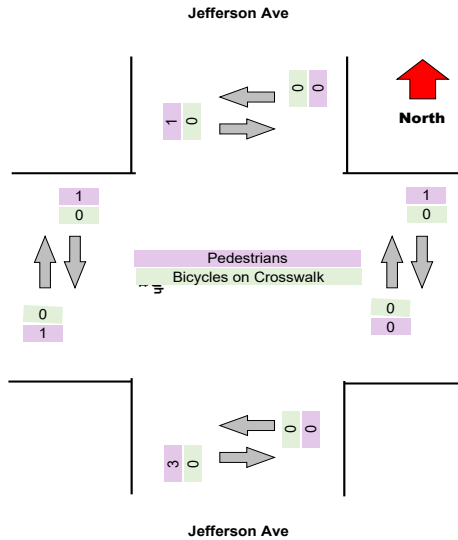
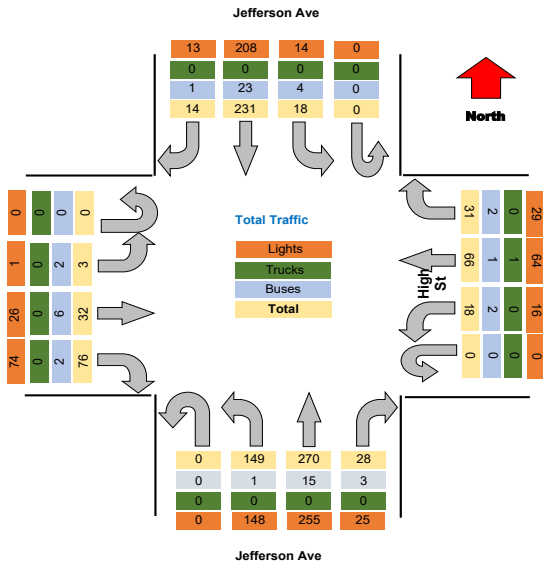

**Turning Movement Peak Hour Data (PM)**

4:15:00 PM

Leg Direction	Jefferson Ave										High St					Jefferson Ave										High St					Total
	Southbound					Westbound					Northbound					Eastbound															
	Right	Thru	Left	U-Turn	App Total	Peds CW	Peds CCW	Right	Thru	Left	U-Turn	App Total	Peds CW	Peds CCW	Right	Thru	Left	U-Turn	App Total	Peds CW	Peds CCW	Right	Thru	Left	U-Turn	App Total	Peds CW	Peds CCW			
4:15:00 PM	2	93	6	0	101	0	0	8	9	7	0	24	1	0	3	63	13	0	79	0	0	27	14	1	0	42	2	0	246		
4:30:00 PM	0	101	6	0	107	0	0	5	15	8	0	28	2	0	5	64	12	0	81	0	0	33	17	6	0	56	0	0	272		
4:45:00 PM	4	82	6	0	92	0	2	8	14	6	0	30	0	2	7	60	12	0	79	0	1	25	13	5	0	43	0	1	244		
5:00:00 PM	2	99	3	0	104	0	0	8	13	6	0	27	0	0	4	76	7	0	87	1	0	19	9	0	0	28	0	0	246		
<b>Grand Total</b>	<b>9</b>	<b>375</b>	<b>21</b>	<b>0</b>	<b>404</b>	<b>0</b>	<b>2</b>	<b>29</b>	<b>51</b>	<b>29</b>	<b>0</b>	<b>109</b>	<b>3</b>	<b>2</b>	<b>19</b>	<b>293</b>	<b>44</b>	<b>0</b>	<b>326</b>	<b>1</b>	<b>1</b>	<b>104</b>	<b>53</b>	<b>12</b>	<b>0</b>	<b>169</b>	<b>2</b>	<b>1</b>	<b>1008</b>		
<b>% Approach</b>	2.0%	92.8%	5.2%	0.0%	0.0%	0.0%	0.0%	26.6%	46.8%	26.6%	0.0%	0.0%	0.0%	0.0%	5.8%	80.7%	13.5%	0.0%	0.0%	0.0%	0.0%	61.5%	31.4%	7.1%	0.0%	0.0%	0.0%	0.0%	0.0%		
<b>% Total</b>	0.8%	37.2%	2.1%	0.0%	40.1%	0.0%	0.0%	2.9%	5.1%	2.9%	0.0%	10.8%	0.0%	0.0%	1.9%	26.1%	4.4%	0.0%	32.3%	0.0%	0.0%	10.3%	5.3%	1.2%	0.0%	16.8%	0.0%	0.0%	0.0%		
<b>PHF</b>	0.500	0.928	0.875	0.000	0.944	0.000	0.000	0.906	0.850	0.906	0.000	0.908	0.000	0.000	0.679	0.865	0.846	0.000	0.837	0.000	0.000	0.788	0.779	0.500	0.000	0.754	0.000	0.000	0.926		
<b>Lights</b>	7	364	19	0	390	0	0	27	46	28	0	101	0	0	19	254	42	0	315	0	0	103	45	12	0	160	0	0	966		
<b>% Lights</b>	87.5%	97.1%	90.5%	0.0%	96.5%	0.0%	0.0%	83.1%	90.2%	96.6%	0.0%	92.7%	0.0%	0.0%	100.0%	96.6%	95.5%	0.0%	96.6%	0.0%	0.0%	99.0%	84.9%	100.0%	0.0%	94.7%	0.0%	0.0%	95.8%		
<b>Trucks</b>	0	0	0	0	0	0	0	0	0	0	0	0	0	0	0	0	0	0	0	0	0	0	0	0	0	0	0	0	0		
<b>% Trucks</b>	0.0%	0.0%	0.0%	0.0%	0.0%	0.0%	0.0%	0.0%	0.0%	0.0%	0.0%	0.0%	0.0%	0.0%	0.0%	0.0%	0.0%	0.0%	0.0%	0.0%	0.0%	0.0%	0.0%	0.0%	0.0%	0.0%	0.0%	0.0%	0.0%		
<b>Buses</b>	1	11	2	0	14	0	0	2	5	1	0	8	0	0	0	9	1	0	10	0	0	1	8	0	0	9	0	0	41		
<b>% Buses</b>	12.5%	2.9%	9.5%	0.0%	0.0%	0.0%	0.0%	6.9%	9.8%	3.4%	0.0%	0.0%	0.0%	0.0%	0.0%	3.4%	2.3%	0.0%	0.0%	0.0%	0.0%	1.0%	15.1%	0.0%	0.0%	0.0%	0.0%	0.0%	4.1%		
<b>Pedestrians</b>	0	0	0	0	0	0	2	0	0	0	0	3	2	0	0	0	0	0	1	1	0	0	0	0	0	0	1	0	0		
<b>% Pedestrians</b>	0.0%	0.0%	0.0%	0.0%	0.0%	0.0%	100.0%	0.0%	0.0%	0.0%	0.0%	0.0%	100.0%	100.0%	0.0%	0.0%	0.0%	0.0%	0.0%	0.0%	100.0%	100.0%	0.0%	0.0%	0.0%	0.0%	0.0%	100.0%	0.0%		
<b>Bicycles on Crosswalk</b>	0	0	0	0	0	0	0	0	0	0	0	0	0	0	0	0	0	0	0	0	0	0	0	0	0	0	2	0	0		
<b>% Bicycles on Crosswalk</b>	0.0%	0.0%	0.0%	0.0%	0.0%	0.0%	0.0%	0.0%	0.0%	0.0%	0.0%	0.0%	0.0%	0.0%	0.0%	0.0%	0.0%	0.0%	0.0%	0.0%	0.0%	0.0%	0.0%	0.0%	0.0%	0.0%	100.0%	0.0%	0.0%		

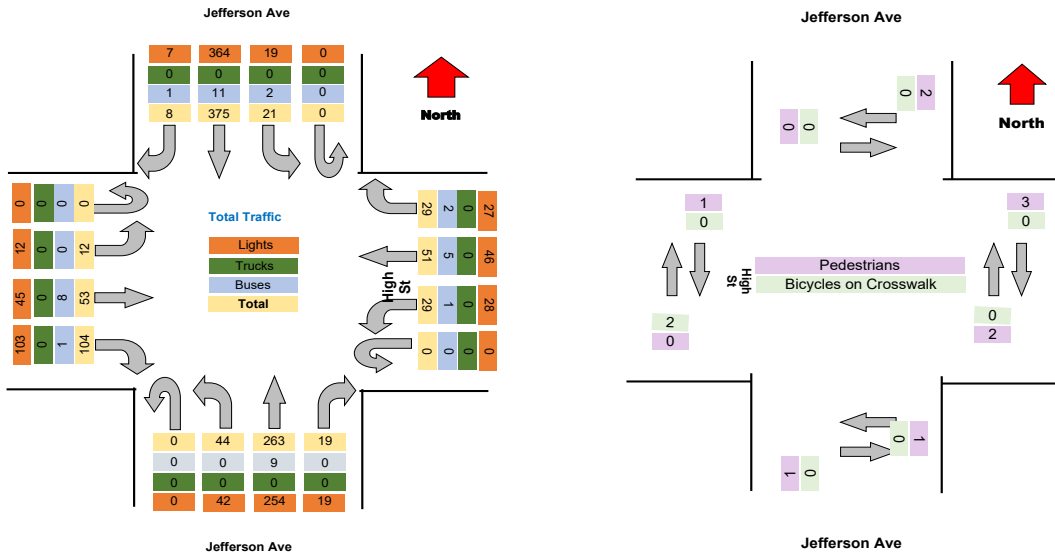





Project : VBH Malta NY  
 Site : Site 4  
 Location : 42.948550, -73.790036  
 Survey Date : 2021-04-28, Wednesday

### Turning Movement Data Plot

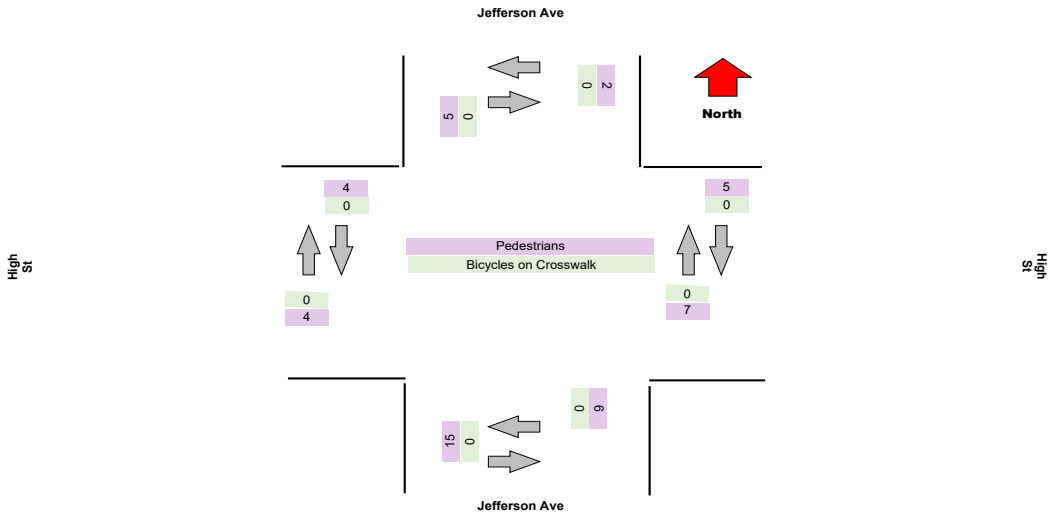
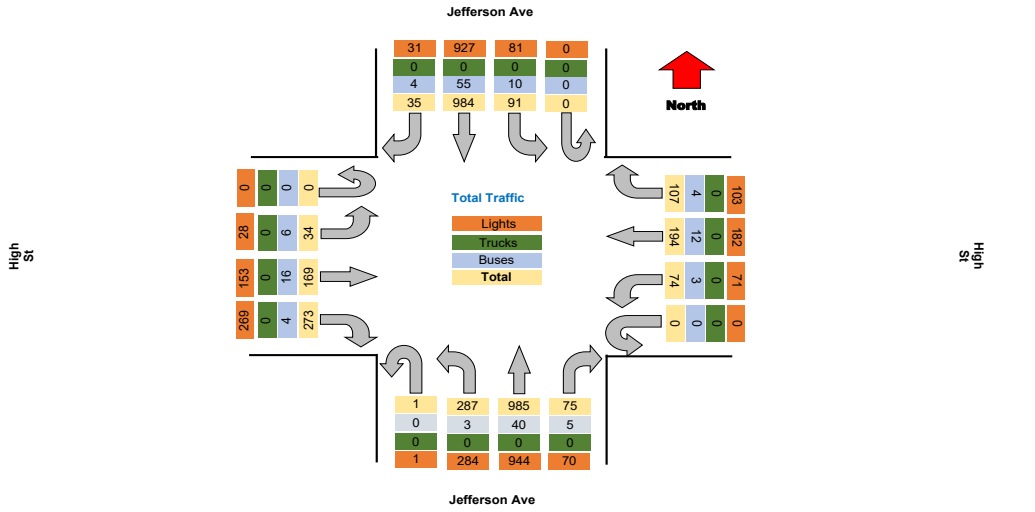

Project : VBH Malta NY  
Site : Site 4  
Location : 42.948550, -73.790036

TSTData.com

Survey Date : 2021-04-28, Wednesday

**Turning Movement Peak Hour Data (AM)**

7:30:00 AM

Leg Direction	Jefferson Ave						High St						Jefferson Ave						High St						Total			
	Southbound			Northbound			Westbound			Eastbound			Northbound			Eastbound												
Start Time	Right	Thru	Left	U-Turn	App Total	Peds CW	Peds CCW	Right	Thru	Left	U-Turn	App Total	Peds CW	Peds CCW	Right	Thru	Left	U-Turn	App Total	Peds CW	Peds CCW	Right	Thru	Left	U-Turn	App Total	Peds CW	Peds CCW
7:30:00 AM	5	48	5	0	58	0	0	9	11	4	0	24	0	0	4	76	32	0	112	0	0	20	5	1	0	26	0	0
7:45:00 AM	4	49	4	0	57	0	1	15	23	9	0	48	0	1	5	95	37	0	138	0	3	16	11	3	0	30	1	2
8:00:00 AM	0	71	11	0	82	0	0	6	16	4	0	26	0	0	6	90	30	0	126	1	0	16	8	0	0	24	1	0
8:15:00 AM	2	49	5	0	56	0	0	5	7	7	0	19	0	0	7	51	28	0	86	0	1	9	6	5	0	20	0	0
<b>Grand Total</b>	<b>11</b>	<b>217</b>	<b>25</b>	<b>0</b>	<b>253</b>	<b>0</b>	<b>1</b>	<b>35</b>	<b>57</b>	<b>24</b>	<b>0</b>	<b>117</b>	<b>0</b>	<b>1</b>	<b>22</b>	<b>312</b>	<b>127</b>	<b>0</b>	<b>439</b>	<b>1</b>	<b>5</b>	<b>61</b>	<b>30</b>	<b>9</b>	<b>0</b>	<b>100</b>	<b>2</b>	<b>2</b>
% Approach	4.3%	85.8%	9.9%	0.0%	0.0%	0.0%	0.0%	29.9%	48.7%	20.5%	0.0%	0.0%	0.0%	0.0%	4.8%	67.5%	27.5%	0.0%	0.0%	0.0%	0.0%	61.0%	30.0%	9.0%	0.0%	0.0%	0.0%	0.0%
% Total	1.2%	23.3%	2.7%	0.0%	27.1%	0.0%	0.0%	3.8%	6.1%	2.6%	0.0%	12.6%	0.0%	0.0%	2.4%	33.5%	13.6%	0.0%	49.6%	0.0%	0.0%	6.5%	3.2%	1.0%	0.0%	10.7%	0.0%	0.0%
PHF	0.550	0.764	0.568	0.000	0.771	0.000	0.000	0.583	0.620	0.667	0.000	0.609	0.000	0.000	0.796	0.821	0.858	0.000	0.837	0.000	0.000	0.763	0.682	0.450	0.000	0.833	0.000	0.000
Lights	9	200	22	0	231	0	0	34	55	22	0	111	0	0	19	297	127	0	443	0	0	60	24	6	0	90	0	0
% Lights	81.8%	92.2%	88.0%	0.0%	91.3%	0.0%	0.0%	87.1%	96.5%	91.7%	0.0%	94.9%	0.0%	0.0%	86.4%	95.2%	100.0%	0.0%	95.9%	0.0%	0.0%	98.4%	80.0%	66.7%	0.0%	90.0%	0.0%	0.0%
Trucks	0	0	0	0	0	0	0	0	0	0	0	0	0	0	0	0	0	0	0	0	0	0	0	0	0	0	0	0
% Trucks	0.0%	0.0%	0.0%	0.0%	0.0%	0.0%	0.0%	0.0%	0.0%	0.0%	0.0%	0.0%	0.0%	0.0%	0.0%	0.0%	0.0%	0.0%	0.0%	0.0%	0.0%	0.0%	0.0%	0.0%	0.0%	0.0%	0.0%	0.0%
Buses	2	17	3	0	22	0	0	1	2	2	0	5	0	0	3	15	0	0	18	0	0	1	6	3	0	10	0	0
% Buses	18.2%	7.8%	12.0%	0.0%	0.0%	0.0%	0.0%	2.9%	3.5%	8.3%	0.0%	0.0%	0.0%	0.0%	13.6%	4.8%	0.0%	0.0%	0.0%	0.0%	0.0%	1.6%	20.0%	33.3%	0.0%	0.0%	0.0%	0.0%
Pedestrians	0	0	0	0	0	1	0	0	0	0	0	0	1	5	0	0	0	0	0	0	0	0	0	0	0	0	2	2
% Pedestrians	0.0%	0.0%	0.0%	0.0%	0.0%	100.0%	0.0%	0.0%	0.0%	0.0%	0.0%	0.0%	100.0%	100.0%	0.0%	0.0%	0.0%	0.0%	0.0%	0.0%	0.0%	0.0%	0.0%	0.0%	0.0%	0.0%	0.0%	100.0%
Bicycles on Crosswalk	0	0	0	0	0	0	0	0	0	0	0	0	0	0	0	0	0	0	0	0	0	0	0	0	0	0	0	0
% Bicycles on Crosswalk	0.0%	0.0%	0.0%	0.0%	0.0%	0.0%	0.0%	0.0%	0.0%	0.0%	0.0%	0.0%	0.0%	0.0%	0.0%	0.0%	0.0%	0.0%	0.0%	0.0%	0.0%	0.0%	0.0%	0.0%	0.0%	0.0%	0.0%	0.0%

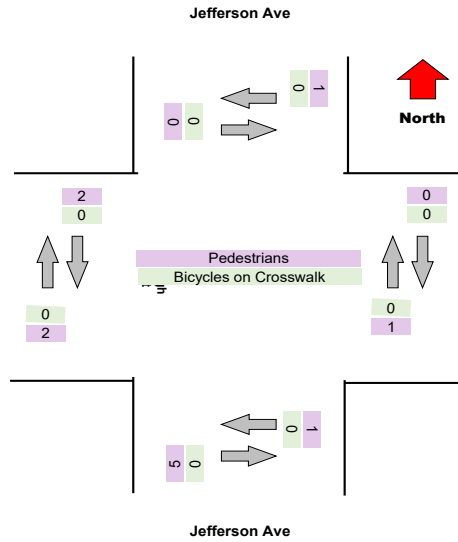
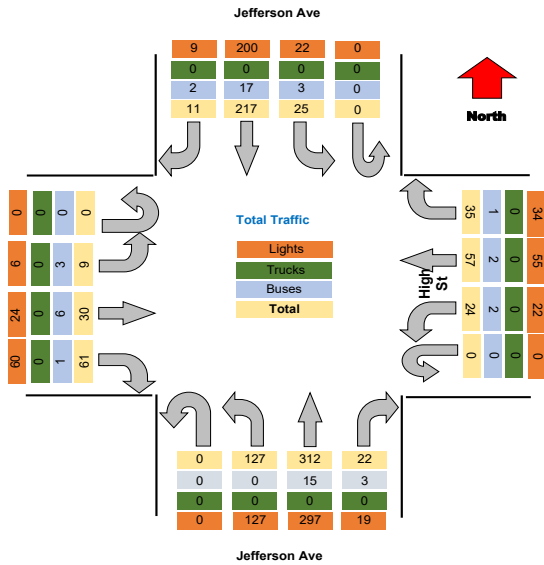

**Turning Movement Peak Hour Data (PM)**

4:15:00 PM

Leg Direction	Jefferson Ave								High St								Jefferson Ave								High St								Total
	Southbound				Westbound				Northbound				Eastbound				Southbound				Westbound				Northbound				Eastbound				
	Right	Thru	Left	U-Turn	App Total	Peds CW	Peds CCW		Right	Thru	Left	U-Turn	App Total	Peds CW	Peds CCW		Right	Thru	Left	U-Turn	App Total	Peds CW	Peds CCW		Right	Thru	Left	U-Turn	App Total	Peds CW	Peds CCW		
4:15:00 PM	1	86	10	0	97	0	0		4	11	10	0	25	0	1		5	67	10	0	82	0	0		24	10	2	0	36	0	0		240
4:30:00 PM	3	92	5	0	100	1	0		7	14	13	0	34	0	0		6	62	13	0	81	0	0		26	28	6	0	60	0	0		276
4:45:00 PM	4	73	4	0	81	0	0		9	12	3	0	24	2	0		5	66	9	0	80	2	1		22	9	3	0	34	0	0		219
5:00:00 PM	0	89	7	0	96	0	0		14	7	2	0	23	0	0		6	56	4	0	66	1	2		37	14	2	0	53	1	1		238
<b>Grand Total</b>	<b>8</b>	<b>349</b>	<b>26</b>	<b>0</b>	<b>374</b>	<b>1</b>	<b>0</b>		<b>34</b>	<b>44</b>	<b>28</b>	<b>0</b>	<b>106</b>	<b>2</b>	<b>1</b>		<b>22</b>	<b>251</b>	<b>36</b>	<b>0</b>	<b>309</b>	<b>3</b>	<b>3</b>		<b>109</b>	<b>61</b>	<b>13</b>	<b>0</b>	<b>183</b>	<b>1</b>	<b>1</b>		<b>972</b>
<b>% Approach</b>	2.1%	99.0%	7.0%	0.0%	0.0%	0.0%	0.0%		32.1%	41.5%	26.4%	0.0%	0.0%	0.0%	0.0%		7.1%	81.2%	11.7%	0.0%	0.0%	0.0%	0.0%		59.6%	33.3%	7.1%	0.0%	0.0%	0.0%	0.0%		
<b>% Total</b>	0.8%	35.0%	2.7%	0.0%	38.5%	0.0%	0.0%		3.5%	4.5%	2.9%	0.0%	10.9%	0.0%	0.0%		2.3%	25.8%	3.7%	0.0%	31.8%	0.0%	0.0%		11.2%	6.3%	1.3%	0.0%	18.8%	0.0%	0.0%		
<b>PHF</b>	0.500	0.924	0.650	0.000	0.935	0.000	0.000		0.607	0.786	0.538	0.000	0.779	0.000	0.000		0.917	0.937	0.692	0.000	0.842	0.000	0.000		0.738	0.545	0.542	0.000	0.763	0.000	0.000		0.884
<b>Lights</b>	7	329	23	0	359	0	0		33	39	27	0	99	0	0		22	242	35	0	299	0	0		109	55	12	0	176	0	0		933
<b>% Lights</b>	87.5%	96.8%	88.5%	0.0%	96.0%	0.0%	0.0%		87.1%	88.6%	96.4%	0.0%	93.4%	0.0%	0.0%		100.0%	96.4%	97.2%	0.0%	96.8%	0.0%	0.0%		100.0%	90.2%	92.3%	0.0%	96.2%	0.0%	0.0%		96.0%
<b>Trucks</b>	0	0	0	0	0	0	0		0	0	0	0	0	0	0		0	0	0	0	0	0	0		0	0	0	0	0	0	0		0
<b>% Trucks</b>	0.0%	0.0%	0.0%	0.0%	0.0%	0.0%	0.0%		0.0%	0.0%	0.0%	0.0%	0.0%	0.0%	0.0%		0.0%	0.0%	0.0%	0.0%	0.0%	0.0%	0.0%		0.0%	0.0%	0.0%	0.0%	0.0%	0.0%	0.0%		0.0%
<b>Buses</b>	1	11	3	0	15	0	0		1	5	1	0	7	0	0		0	8	1	0	9	0	0		0	6	1	0	7	0	0		38
<b>% Buses</b>	12.5%	3.2%	11.5%	0.0%	0.0%	0.0%	0.0%		2.9%	11.4%	3.6%	0.0%	0.0%	0.0%	0.0%		0.0%	3.2%	2.8%	0.0%	0.0%	0.0%	0.0%		0.0%	9.8%	7.7%	0.0%	0.0%	0.0%	0.0%		3.9%
<b>Pedestrians</b>	0	0	0	0	0	1	0		0	0	0	0	0	2	1		0	0	0	0	3	3	1		0	0	0	0	0	1	1		0
<b>% Pedestrians</b>	0.0%	0.0%	0.0%	0.0%	0.0%	100.0%	0.0%		0.0%	0.0%	0.0%	0.0%	0.0%	100.0%	100.0%		0.0%	0.0%	0.0%	0.0%	0.0%	100.0%	100.0%		0.0%	0.0%	0.0%	0.0%	0.0%	100.0%	100.0%		0.0%
<b>Bicycles on Crosswalk</b>	0	0	0	0	0	0	0		0	0	0	0	0	0	0		0	0	0	0	0	0	0		0	0	0	0	0	0	0		0
<b>% Bicycles on Crosswalk</b>	0.0%	0.0%	0.0%	0.0%	0.0%	0.0%	0.0%		0.0%	0.0%	0.0%	0.0%	0.0%	0.0%	0.0%		0.0%	0.0%	0.0%	0.0%	0.0%	0.0%	0.0%		0.0%	0.0%	0.0%	0.0%	0.0%	0.0%	0.0%		0.0%

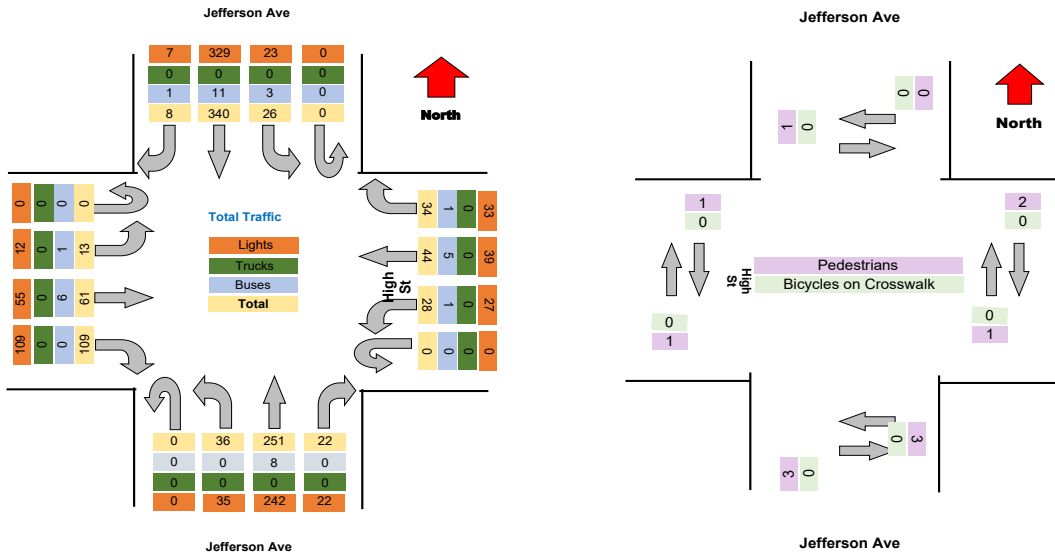

Project : VBH Malta NY  
Site : Site 4  
Location : 42.948550, -73.790036

TSTData.com

Survey Date : 2021-04-28, Wednesday

Project	LaBella
Project Code	LaBella
Site Name	39
Legs and Movements	All Processed Legs & Move
Bin Size	15 minutes
Survey Date	2021-11-02, Tuesday
Location	39
Latitude and Longitude	42.914728, -78.848108

	Start	End	PHF
Forced Peak AM	2021/11/02 07:30:00	2021/11/02 08:30:00	0.85
Forced Peak PM	2021/11/02 16:30:00	2021/11/02 17:30:00	0.89
AM Peak	2021/11/02 07:30:00	2021/11/02 08:30:00	0.85
PM Peak	2021/11/02 16:30:00	2021/11/02 17:30:00	0.89

### Turning Movement Data

Leg Direction	Wohlers Ave Southbound							E Ferry St Westbound							Wohlers Ave Northbound							E Ferry St Eastbound							Total
	Right	Thru	Left	U-Turn	App Total	Peds CV	Peds CCV	Right	Thru	Left	U-Turn	App Total	Peds CV	Peds CCV	Right	Thru	Left	U-Turn	App Total	Peds CV	Peds CCV	Right	Thru	Left	U-Turn	App Total	Peds CV	Peds CCV	
	Start Time																												
6:30:00 AM	0	0	0	0	0	0	0	6	62	2	0	70	0	0	4	3	2	0	9	0	0	1	33	1	0	35	0	0	114
6:45:00 AM	0	0	0	0	0	0	0	3	58	0	0	61	0	0	2	2	1	0	5	1	0	1	23	1	0	25	0	0	91
Hourly Total	0	0	0	0	0	0	0	9	120	2	0	131	0	0	6	5	3	0	14	1	0	2	56	2	0	60	0	0	205
7:00:00 AM	0	0	0	0	0	0	0	5	47	0	0	52	0	0	2	3	0	0	5	1	1	3	34	3	0	40	0	0	97
7:15:00 AM	0	0	0	0	0	0	0	7	61	0	0	68	0	0	2	5	1	0	8	0	0	2	27	3	0	32	0	0	108
7:30:00 AM	0	0	0	0	0	0	0	7	69	0	0	76	0	1	6	5	0	0	12	0	0	2	33	2	0	37	0	0	125
7:45:00 AM	0	1	0	0	1	0	1	9	120	1	0	131	0	0	6	3	3	0	12	0	0	0	44	1	0	45	0	0	189
Hourly Total	0	1	0	0	1	0	1	28	297	1	0	327	0	1	16	16	4	0	37	1	1	7	138	9	0	154	0	0	519
8:00:00 AM	0	0	0	0	0	7	5	8	95	3	0	111	0	0	9	5	1	0	15	0	0	1	39	4	0	44	0	1	170
8:15:00 AM	0	0	0	0	0	0	0	12	82	1	0	95	0	0	8	3	0	0	11	0	0	4	42	7	0	53	2	2	159
Hourly Total	0	0	0	0	0	7	5	20	177	4	0	206	0	0	17	8	1	0	26	0	0	5	81	11	0	97	2	3	329
4:00:00 PM	0	0	0	0	0	2	3	22	93	1	0	116	1	0	9	17	5	0	31	1	0	3	94	13	0	110	3	6	257
4:15:00 PM	0	0	0	0	0	1	0	16	116	4	0	136	0	1	8	9	1	0	18	0	1	6	72	10	0	88	2	6	242
4:30:00 PM	0	0	0	0	0	1	1	19	110	2	0	131	0	1	12	9	4	0	25	0	1	4	76	10	0	90	6	6	246
4:45:00 PM	0	0	0	0	0	1	0	23	95	3	0	121	0	0	11	11	1	0	23	0	1	4	77	8	0	89	3	2	233
Hourly Total	0	0	0	0	0	5	4	80	414	10	0	504	1	1	40	46	11	0	97	1	3	17	319	41	0	377	13	20	978
5:00:00 PM	0	0	0	0	0	1	2	17	96	2	0	115	0	1	7	10	2	0	19	0	0	6	83	22	0	111	3	1	245
5:15:00 PM	0	0	0	0	0	1	4	24	132	6	0	162	0	1	9	12	3	0	24	0	2	6	79	12	0	97	3	5	283
5:30:00 PM	0	0	0	0	0	0	1	21	106	3	0	130	2	0	11	11	6	0	28	0	0	1	61	13	0	75	5	4	233
5:45:00 PM	0	0	0	0	0	2	1	18	114	1	0	133	0	1	17	5	3	0	25	1	1	5	58	10	0	73	7	7	231
Hourly Total	0	0	0	0	0	4	8	80	448	12	0	540	2	3	44	38	14	0	96	1	3	18	281	57	0	356	18	17	992
Grand Total	0	1	0	0	1	15	18	217	1456	29	0	1708	3	5	123	113	33	0	270	4	7	49	875	120	0	1044	33	40	3023
% Approach	0.0%	100.0%	0.0%	0.0%	0.0%	0.0%	0.0%	12.7%	85.2%	1.7%	0.0%	0.0%	0.0%	45.6%	41.9%	12.2%	0.0%	0.0%	0.0%	0.0%	4.7%	83.8%	11.5%	0.0%	0.0%	0.0%	0.0%	0.0%	
% Total	0.0%	0.0%	0.0%	0.0%	0.0%	0.0%	0.0%	7.2%	48.2%	1.0%	0.0%	86.5%	0.0%	0.0%	4.1%	3.7%	1.1%	0.0%	8.9%	0.0%	0.0%	1.6%	28.9%	4.0%	0.0%	34.5%	0.0%	0.0%	0.0%
Lights	0	1	0	0	1	0	0	213	1427	27	0	1667	0	0	123	109	33	0	265	0	0	48	860	120	0	1028	0	0	2961
% Lights	0.0%	100.0%	0.0%	0.0%	100.0%	0.0%	0.0%	98.2%	98.0%	93.1%	0.0%	97.6%	0.0%	0.0%	100.0%	96.5%	100.0%	0.0%	96.1%	0.0%	0.0%	98.0%	98.3%	100.0%	0.0%	98.5%	0.0%	0.0%	97.9%
Trucks	0	0	0	0	0	0	0	0	2	0	0	2	0	0	0	0	0	0	0	0	0	0	0	0	0	0	0	0	2
% Trucks	0.0%	0.0%	0.0%	0.0%	0.0%	0.0%	0.0%	0.0%	0.1%	0.0%	0.0%	0.1%	0.0%	0.0%	0.0%	0.0%	0.0%	0.0%	0.0%	0.0%	0.0%	0.0%	0.0%	0.0%	0.0%	0.0%	0.0%	0.0%	0.1%
Buses	0	0	0	0	0	0	0	4	26	2	0	32	0	0	0	4	0	0	4	0	0	1	14	0	0	15	0	0	51
% Buses	0.0%	0.0%	0.0%	0.0%	0.0%	0.0%	0.0%	0.0%	1.8%	6.9%	0.0%	0.0%	0.0%	0.0%	0.0%	3.5%	0.0%	0.0%	0.0%	0.0%	0.0%	2.0%	1.6%	0.0%	0.0%	0.0%	0.0%	0.0%	1.7%
Pedestrians	0	0	0	0	0	14	17	0	0	0	0	0	3	5	0	0	0	0	0	4	7	0	0	0	0	0	33	36	0
% Pedestrians	0.0%	0.0%	0.0%	0.0%	0.0%	87.5%	84.4%	0.0%	0.0%	0.0%	0.0%	0.0%	100.0%	100.0%	0.0%	0.0%	0.0%	0.0%	0.0%	100.0%	100.0%	0.0%	0.0%	0.0%	0.0%	0.0%	100.0%	80.0%	0.0%
Bicycles on Crosswalk	0	0	0	0	0	2	1	0	0	0	0	0	0	0	0	0	0	0	0	0	0	0	0	0	0	0	0	4	0
% Bicycles on Crosswalk	0.0%	0.0%	0.0%	0.0%	0.0%	12.5%	5.6%	0.0%	0.0%	0.0%	0.0%	0.0%	0.0%	0.0%	0.0%	0.0%	0.0%	0.0%	0.0%	0.0%	0.0%	0.0%	0.0%	0.0%	0.0%	0.0%	0.0%	10.0%	0.0%

Project : VBH Malta NY  
 Site : Site 4  
 Location : 42.948550, -73.790036  
 Survey Date : 2021-04-28, Wednesday

### Turning Movement Data Plot

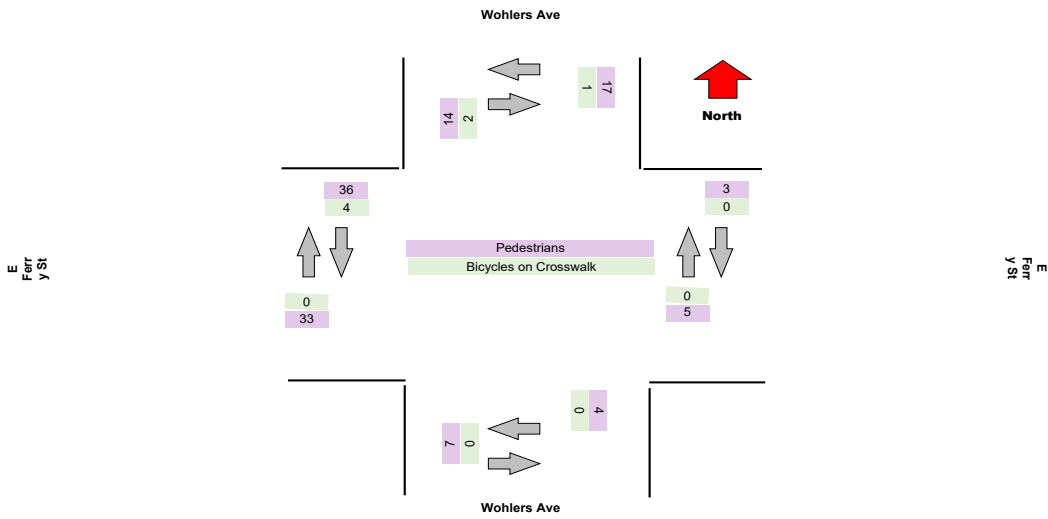
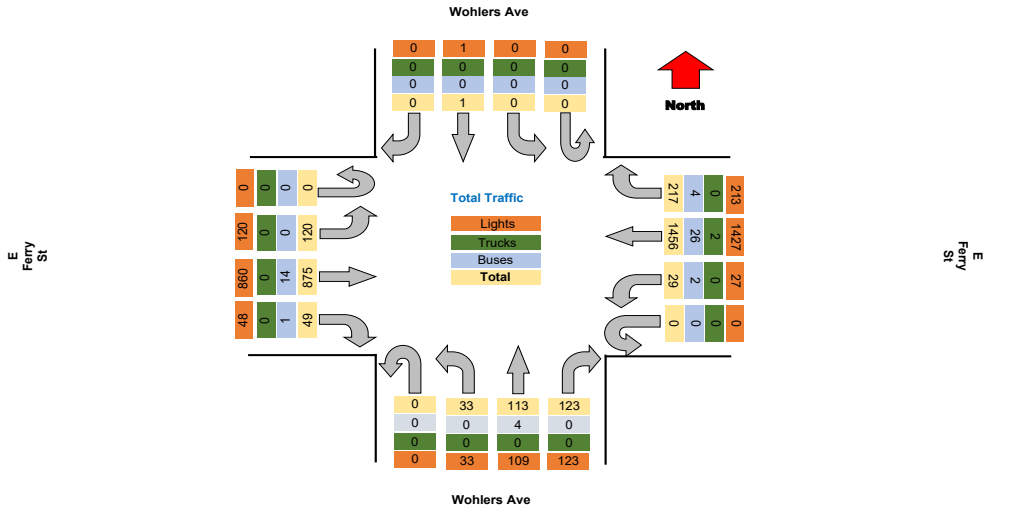

Project : VBH Malta NY  
Site : Site 4  
Location : 42.948550, -73.790036

TSTData.com

Survey Date : 2021-04-28, Wednesday

### Turning Movement Peak Hour Data (AM)

7:30:00 AM

Leg Direction	Wohlers Ave										E Ferry St										Wohlers Ave										E Ferry St										Total
	Southbound					Westbound					Northbound					Eastbound					Northbound					Eastbound															
	Right	Thru	Left	U-Turn	App Total	Right	Thru	Left	U-Turn	App Total	Right	Thru	Left	U-Turn	App Total	Right	Thru	Left	U-Turn	App Total	Right	Thru	Left	U-Turn	App Total	Right	Thru	Left	U-Turn	App Total	Right	Thru	Left	U-Turn	App Total						
7:30:00 AM	0	0	0	0	0	7	69	0	0	76	0	0	1	0	1	6	5	0	0	12	0	0	0	0	0	2	33	2	0	37	0	0	0	0	0	125					
7:45:00 AM	0	1	0	0	1	9	120	1	0	131	0	0	0	0	0	6	3	3	0	12	0	0	0	0	0	0	44	1	0	45	0	0	0	0	0	189					
8:00:00 AM	0	0	0	0	0	8	95	3	0	111	0	0	0	0	0	9	5	1	0	15	0	0	0	0	0	1	39	4	0	44	0	0	0	0	0	170					
8:15:00 AM	0	0	0	0	0	12	62	1	0	75	0	0	0	0	0	8	3	0	0	11	0	0	0	0	0	4	42	7	0	53	2	2	2	2	158						
<b>Grand Total</b>	0	1	0	0	1	36	356	5	0	413	0	0	1	0	1	29	16	4	0	49	0	0	0	0	0	7	158	14	0	179	2	2	2	2	643						
% Approach	0.0%	100.0%	0.0%	0.0%	0.0%	8.7%	88.6%	1.2%	0.0%	0.0%	0.0%	0.0%	0.0%	0.0%	0.0%	58.0%	32.0%	8.0%	0.0%	0.0%	0.0%	0.0%	0.0%	0.0%	0.0%	3.9%	85.3%	7.8%	0.0%	0.0%	0.0%	0.0%	0.0%	0.0%	0.0%						
% Total	0.0%	0.2%	0.0%	0.0%	0.2%	5.6%	56.9%	0.8%	0.0%	64.2%	0.0%	0.0%	0.0%	0.0%	0.0%	4.5%	2.5%	0.6%	0.0%	7.6%	0.0%	0.0%	0.0%	0.0%	0.0%	1.1%	24.6%	2.2%	0.0%	27.8%	0.0%	0.0%	0.0%	0.0%	0.0%						
PHF	0.000	0.250	0.000	0.000	0.250	0.750	0.783	0.417	0.000	0.788	0.000	0.000	0.000	0.000	0.000	0.806	0.800	0.333	0.000	0.833	0.000	0.000	0.000	0.000	0.000	0.438	0.888	0.500	0.000	0.844	0.000	0.000	0.000	0.000	0.851						
Lights	0	1	0	0	1	33	358	5	0	396	0	0	0	0	0	29	15	4	0	48	0	0	0	0	0	7	155	14	0	176	0	0	0	0	0	621					
% Lights	0.0%	100.0%	0.0%	0.0%	100.0%	81.7%	97.8%	100.0%	0.0%	95.9%	0.0%	0.0%	0.0%	0.0%	0.0%	100.0%	93.8%	100.0%	0.0%	96.0%	0.0%	0.0%	0.0%	0.0%	0.0%	100.0%	98.1%	100.0%	0.0%	98.3%	0.0%	0.0%	0.0%	0.0%	96.6%						
Trucks	0	0	0	0	0	0	1	0	0	1	0	0	0	0	0	0	0	0	0	0	0	0	0	0	0	0	0	0	0	0	0	0	0	0	0	1					
% Trucks	0.0%	0.0%	0.0%	0.0%	0.0%	0.0%	0.3%	0.0%	0.0%	0.2%	0.0%	0.0%	0.0%	0.0%	0.0%	0.0%	0.0%	0.0%	0.0%	0.0%	0.0%	0.0%	0.0%	0.0%	0.0%	0.0%	0.0%	0.0%	0.0%	0.0%	0.0%	0.0%	0.0%	0.0%	0.2%						
Buses	0	0	0	0	0	3	6	0	0	9	0	0	0	0	0	0	1	0	0	1	0	0	0	0	0	0	3	0	0	3	0	0	0	0	0	13					
% Buses	0.0%	0.0%	0.0%	0.0%	0.0%	8.3%	1.6%	0.0%	0.0%	0.0%	0.0%	0.0%	0.0%	0.0%	0.0%	0.0%	6.3%	0.0%	0.0%	0.0%	0.0%	0.0%	0.0%	0.0%	0.0%	0.0%	1.9%	0.0%	0.0%	0.0%	0.0%	0.0%	0.0%	0.0%	2.0%						
Pedestrians	0	0	0	0	0	0	0	0	0	0	0	1	0	0	1	0	0	0	0	0	0	0	0	0	0	0	0	0	0	0	0	2	3	0	5						
% Pedestrians	0.0%	0.0%	0.0%	0.0%	0.0%	0.0%	0.0%	0.0%	0.0%	0.0%	0.0%	100.0%	0.0%	0.0%	100.0%	0.0%	0.0%	0.0%	0.0%	0.0%	0.0%	0.0%	0.0%	0.0%	0.0%	0.0%	0.0%	0.0%	0.0%	0.0%	0.0%	100.0%	100.0%	0.0%	0.0%						
Bicycles on Crosswalk	0	0	0	0	0	0	0	0	0	0	0	0	0	0	0	0	0	0	0	0	0	0	0	0	0	0	0	0	0	0	0	0	0	0	0	0					
% Bicycles on Crosswalk	0.0%	0.0%	0.0%	0.0%	0.0%	0.0%	0.0%	0.0%	0.0%	0.0%	0.0%	0.0%	0.0%	0.0%	0.0%	0.0%	0.0%	0.0%	0.0%	0.0%	0.0%	0.0%	0.0%	0.0%	0.0%	0.0%	0.0%	0.0%	0.0%	0.0%	0.0%	0.0%	0.0%	0.0%	0.0%						

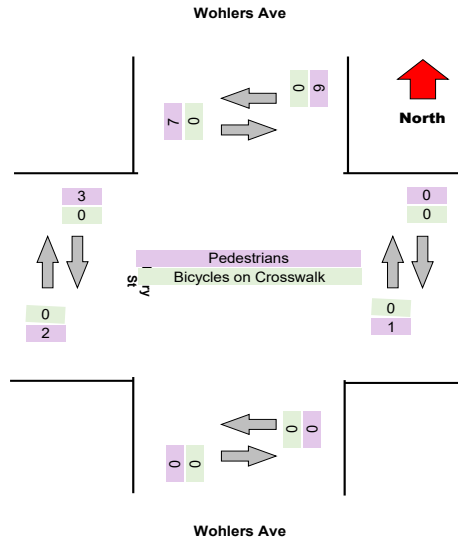
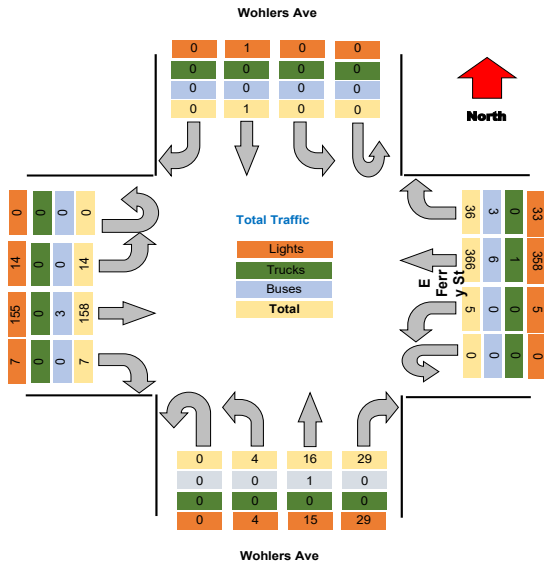

**Turning Movement Peak Hour Data (PM)**

4:30:00 PM

Leg Direction	Wohlers Ave										E Ferry St										Wohlers Ave										E Ferry St										Total
	Southbound					Westbound					Northbound					Eastbound																									
	Right	Thru	Left	U-Turn	App Total	Right	Thru	Left	U-Turn	App Total	Right	Thru	Left	U-Turn	App Total	Right	Thru	Left	U-Turn	App Total																					
4:30:00 PM	0	0	0	0	0	19	110	2	0	131	12	9	4	0	25	4	76	10	0	90	6	6	0	0	12	246															
4:45:00 PM	0	0	0	0	0	23	95	3	0	121	11	11	1	0	23	4	77	8	0	89	2	2	0	0	4	233															
5:00:00 PM	0	0	0	0	0	17	96	2	0	115	7	10	2	0	19	0	63	22	0	111	3	1	0	0	5	245															
5:15:00 PM	0	0	0	0	0	24	132	6	0	162	9	12	3	0	24	6	79	12	0	97	3	5	0	0	13	233															
Grand Total	0	0	0	0	0	83	433	13	0	529	39	42	10	0	91	20	315	52	0	387	14	14	0	0	28	1007															
% Approach	#DIV/0!	#DIV/0!	#DIV/0!	#DIV/0!	0.0%	15.7%	81.9%	2.5%	0.0%	0.0%	42.9%	46.2%	11.0%	0.0%	0.0%	5.2%	81.4%	13.4%	0.0%	0.0%	0.0%	0.0%	0.0%	0.0%	0.0%																
% Total	0.0%	0.0%	0.0%	0.0%	0.0%	8.2%	43.0%	1.3%	0.0%	52.5%	3.9%	4.2%	1.0%	0.0%	8.0%	2.0%	31.3%	5.2%	0.0%	38.4%	0.0%	0.0%	0.0%	0.0%	0.0%																
PHF	0.000	0.000	0.000	0.000	0.000	0.865	0.820	0.542	0.000	0.816	0.813	0.875	0.625	0.000	0.910	0.833	0.849	0.591	0.000	0.872	0.000	0.000	0.000	0.000	0.000	0.890															
Lights	0	0	0	0	0	82	427	13	0	522	39	42	10	0	91	20	311	52	0	383	0	0	0	0	0	996															
% Lights	0.0%	0.0%	0.0%	0.0%	0.0%	98.8%	98.6%	100.0%	0.0%	98.7%	100.0%	100.0%	100.0%	0.0%	100.0%	100.0%	98.7%	100.0%	0.0%	99.0%	0.0%	0.0%	0.0%	0.0%	0.0%	98.9%															
Trucks	0	0	0	0	0	0	1	0	0	1	0	0	0	0	0	0	0	0	0	0	0	0	0	0	0	1															
% Trucks	0.0%	0.0%	0.0%	0.0%	0.0%	0.0%	0.2%	0.0%	0.0%	0.2%	0.0%	0.0%	0.0%	0.0%	0.0%	0.0%	0.0%	0.0%	0.0%	0.0%	0.0%	0.0%	0.0%	0.0%	0.0%	0.1%															
Buses	0	0	0	0	0	1	5	0	0	6	0	0	0	0	0	0	4	0	0	4	0	0	0	0	0	10															
% Buses	0.0%	0.0%	0.0%	0.0%	0.0%	1.2%	1.2%	0.0%	0.0%	0.0%	0.0%	0.0%	0.0%	0.0%	0.0%	0.0%	1.3%	0.0%	0.0%	0.0%	0.0%	0.0%	0.0%	0.0%	0.0%	1.0%															
Pedestrians	0	0	0	0	3	0	0	0	0	0	0	0	0	0	4	0	0	0	0	0	14	13	0	0	0	27															
% Pedestrians	0.0%	0.0%	0.0%	0.0%	75.0%	0.0%	0.0%	0.0%	0.0%	0.0%	0.0%	0.0%	0.0%	0.0%	0.0%	0.0%	0.0%	0.0%	0.0%	0.0%	100.0%	92.9%	0.0%	0.0%	0.0%	0.9%															
Bicycles on Crosswalk	0	0	0	0	1	0	0	0	0	0	0	0	0	0	0	0	0	0	0	0	0	0	0	0	1	1															
% Bicycles on Crosswalk	0.0%	0.0%	0.0%	0.0%	0.0%	0.0%	0.0%	0.0%	0.0%	0.0%	0.0%	0.0%	0.0%	0.0%	0.0%	0.0%	0.0%	0.0%	0.0%	0.0%	0.0%	0.0%	0.0%	0.0%	7.1%	0.0%															

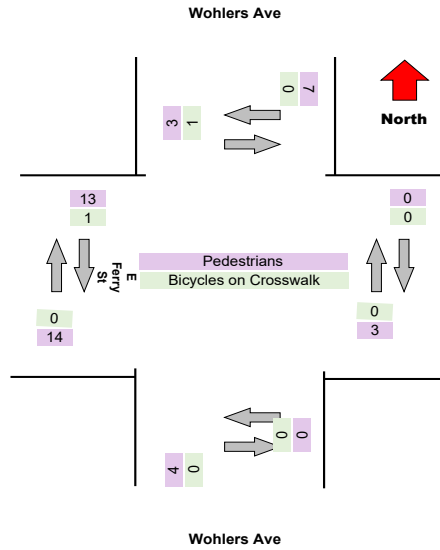
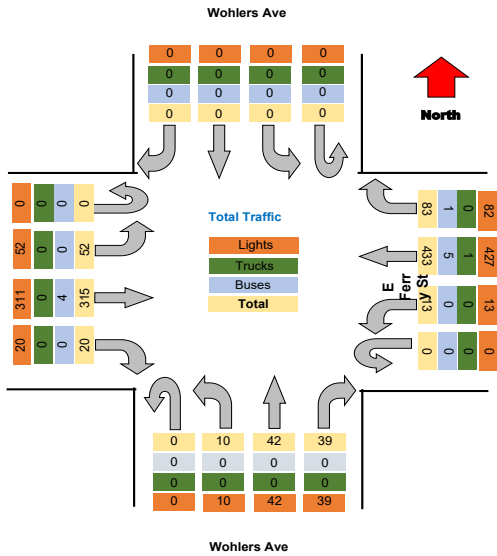





Project : VBH Malta NY  
 Site : Site 4  
 Location : 42.948550, -73.790036  
 Survey Date : 2021-04-28, Wednesday

### Turning Movement Data Plot

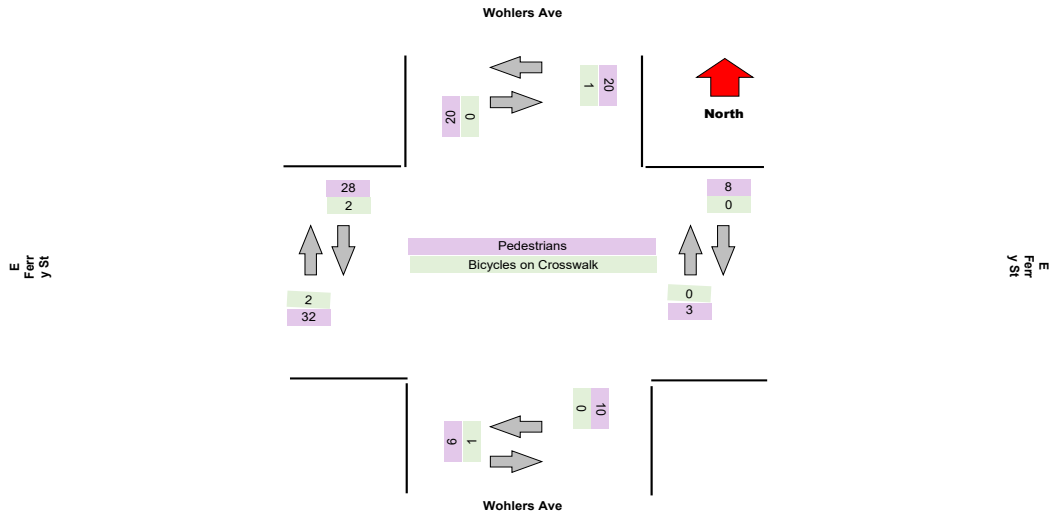
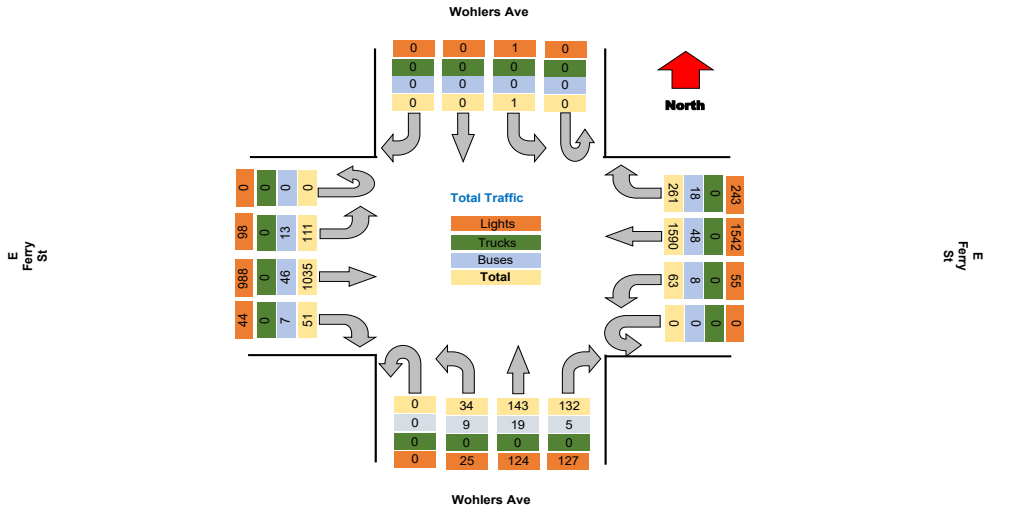

Project : VBH Malta NY  
Site : Site 4  
Location : 42.948550, -73.790036

TSTData.com

Survey Date : 2021-04-28, Wednesday

### Turning Movement Peak Hour Data (AM)

7:30:00 AM

Leg Direction	Wohlers Ave								E Ferry St								Wohlers Ave								E Ferry St								Total
	Southbound				Westbound				Northbound				Eastbound				Northbound				Eastbound												
Start Time	Right	Thru	Left	U-Turn	App Total	Peds CW	Peds CCW		Right	Thru	Left	U-Turn	App Total	Peds CW	Peds CCW		Right	Thru	Left	U-Turn	App Total	Peds CW	Peds CCW		Right	Thru	Left	U-Turn	App Total	Peds CW	Peds CCW		
7:30:00 AM	0	0	0	0	0	0	0		5	122	2	0	129	0	1		10	12	3	0	26	0	0		0	61	6	0	67	1	1		222
7:45:00 AM	0	0	0	0	0	0	1		13	147	2	0	163	0	0		7	6	2	0	15	1	0		1	79	5	0	85	2	1		263
8:00:00 AM	0	0	0	0	0	3	0		11	120	9	0	140	2	0		9	4	4	0	19	1	0		1	57	1	0	59	3	4		218
8:15:00 AM	0	0	0	0	0	0	1		20	84	10	0	115	0	0		9	7	2	0	18	0	0		2	49	4	0	55	2	1		168
Grand Total	0	0	0	0	0	3	1		49	473	23	0	547	2	1		35	29	11	0	75	2	0		4	246	16	0	256	3	7		891
% Approach	#DIV/0!	#DIV/0!	#DIV/0!	#DIV/0!	0.0%	0.0%	0.0%		9.0%	86.5%	4.2%	0.0%	0.0%	0.0%	0.0%		44.0%	37.2%	14.1%	0.0%	0.0%	0.0%	0.0%		1.5%	92.5%	6.0%	0.0%	0.0%	0.0%	0.0%		
% Total	0.0%	0.0%	0.0%	0.0%	0.0%	0.0%	0.0%		5.5%	53.1%	2.6%	0.0%	61.4%	0.0%	0.0%		3.9%	3.3%	1.2%	0.0%	8.8%	0.0%	0.0%		0.4%	27.6%	1.8%	0.0%	29.9%	0.0%	0.0%		
PHF	0.000	0.000	0.000	0.000	0.000	0.000	0.000		0.613	0.804	0.575	0.000	0.839	0.000	0.000		0.875	0.604	0.688	0.000	0.750	0.000	0.000		0.500	0.778	0.667	0.000	0.782	0.000	0.000		0.847
Lights	0	0	0	0	0	0	0		43	456	23	0	522	0	0		33	24	6	0	63	0	0		4	225	11	0	240	0	0		825
% Lights	0.0%	0.0%	0.0%	0.0%	0.0%	0.0%	0.0%		87.8%	96.4%	100.0%	0.0%	95.4%	0.0%	0.0%		84.3%	82.8%	54.5%	0.0%	80.8%	0.0%	0.0%		100.0%	91.5%	68.8%	0.0%	90.2%	0.0%	0.0%		92.6%
Trucks	0	0	0	0	0	0	0		0	0	0	0	0	0	0		0	0	0	0	0	0	0		0	0	0	0	0	0	0		0
% Trucks	0.0%	0.0%	0.0%	0.0%	0.0%	0.0%	0.0%		0.0%	0.0%	0.0%	0.0%	0.0%	0.0%	0.0%		0.0%	0.0%	0.0%	0.0%	0.0%	0.0%	0.0%		0.0%	0.0%	0.0%	0.0%	0.0%	0.0%	0.0%		0.0%
Buses	0	0	0	0	0	0	0		6	17	0	0	23	0	0		2	5	5	0	12	0	0		0	21	5	0	26	0	0		61
% Buses	0.0%	0.0%	0.0%	0.0%	0.0%	0.0%	0.0%		12.2%	3.6%	0.0%	0.0%	0.0%	0.0%	0.0%		5.7%	17.2%	45.5%	0.0%	0.0%	0.0%	0.0%		0.0%	8.5%	31.3%	0.0%	0.0%	0.0%	0.0%		6.8%
Pedestrians	0	0	0	0	3	2	0		0	0	0	0	2	1	0		0	0	0	0	2	0	0		0	0	0	0	0	8	7		7
% Pedestrians	0.0%	0.0%	0.0%	0.0%	0.0%	100.0%	100.0%		0.0%	0.0%	0.0%	0.0%	0.0%	100.0%	100.0%		0.0%	0.0%	0.0%	0.0%	0.0%	100.0%	100.0%		0.0%	0.0%	0.0%	0.0%	0.0%	100.0%	100.0%		0.0%
Bicycles on Crosswalk	0	0	0	0	0	0	0		0	0	0	0	0	0	0		0	0	0	0	0	0	0		0	0	0	0	0	0	0		0
% Bicycles on Crosswalk	0.0%	0.0%	0.0%	0.0%	0.0%	0.0%	0.0%		0.0%	0.0%	0.0%	0.0%	0.0%	0.0%	0.0%		0.0%	0.0%	0.0%	0.0%	0.0%	0.0%	0.0%		0.0%	0.0%	0.0%	0.0%	0.0%	0.0%	0.0%		0.0%

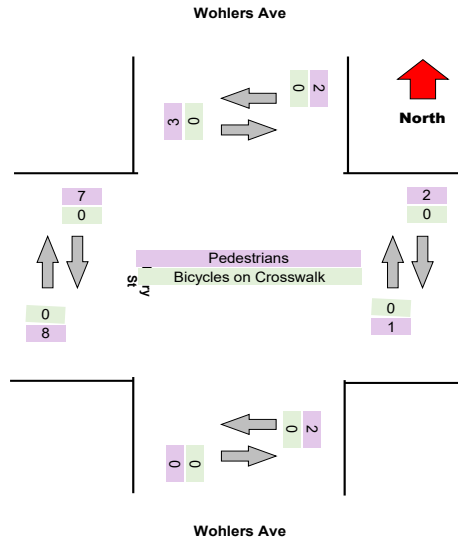
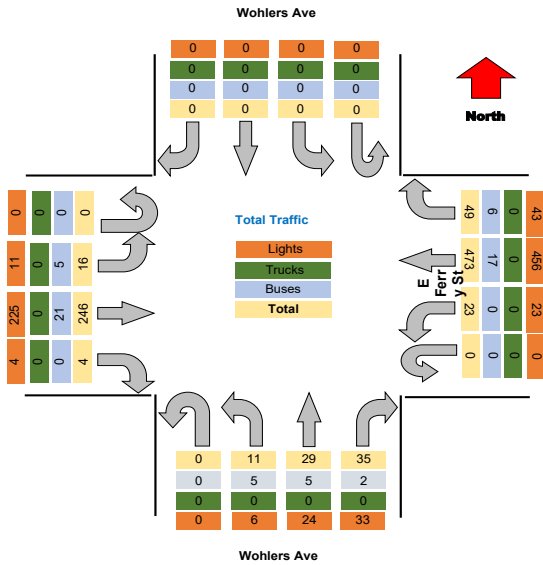

**Turning Movement Peak Hour Data (PM)**

4:30:00 PM

Leg Direction	Wohlers Ave				E Ferry St				Wohlers Ave				E Ferry St				Total												
	Southbound				Westbound				Northbound				Eastbound																
	Right	Thru	Left	U-Turn	App Total	Peds CW	Peds CCW	Right	Thru	Left	U-Turn	App Total	Peds CW	Peds CCW	Right	Thru		Left	U-Turn	App Total	Peds CW	Peds CCW							
4:30:00 PM	0	0	0	0	0	3	1	23	107	7	0	137	0	0	10	7	2	0	19	0	0	3	89	14	0	106	3	2	262
4:45:00 PM	0	0	0	0	0	2	2	25	104	3	0	132	0	0	13	13	0	0	26	1	0	0	82	7	0	89	5	0	247
5:00:00 PM	0	0	0	0	0	0	0	24	101	4	0	129	1	1	4	11	2	0	17	1	0	5	75	11	0	91	0	2	237
5:15:00 PM	0	0	0	0	0	4	0	24	123	1	0	148	0	0	8	7	2	0	17	0	1	4	86	14	0	104	4	3	259
Grand Total	0	0	0	0	0	9	0	96	435	15	0	546	1	1	35	39	6	0	79	2	1	12	332	45	0	390	12	7	1015
% Approach	#DIV/0!	#DIV/0!	#DIV/0!	#DIV/0!	0.0%	0.0%	0.0%	17.6%	79.7%	2.7%	0.0%	0.0%	0.0%	0.0%	44.3%	48.1%	7.6%	0.0%	0.0%	0.0%	0.0%	3.1%	85.1%	11.8%	0.0%	0.0%	0.0%	0.0%	
% Total	0.0%	0.0%	0.0%	0.0%	0.0%	0.0%	0.0%	9.5%	42.9%	1.5%	0.0%	53.8%	0.0%	0.0%	3.4%	3.7%	0.6%	0.0%	7.6%	0.0%	0.0%	1.2%	32.7%	4.5%	0.0%	38.4%	0.0%	0.0%	
PHF	0.000	0.000	0.000	0.000	0.000	0.000	0.000	0.960	0.884	0.536	0.000	0.922	0.000	0.000	0.673	0.731	0.750	0.000	0.760	0.000	0.000	0.600	0.933	0.821	0.000	0.920	0.000	0.000	0.943
Lights	0	0	0	0	0	0	0	93	425	14	0	532	0	0	33	34	4	0	71	0	0	11	322	45	0	378	0	0	981
% Lights	0.0%	0.0%	0.0%	0.0%	0.0%	0.0%	0.0%	96.9%	97.7%	93.3%	0.0%	97.4%	0.0%	0.0%	94.3%	89.5%	66.7%	0.0%	89.9%	0.0%	0.0%	91.7%	97.0%	97.8%	0.0%	96.9%	0.0%	0.0%	96.7%
Trucks	0	0	0	0	0	0	0	0	0	0	0	0	0	0	0	0	0	0	0	0	0	0	0	0	0	0	0	0	0
% Trucks	0.0%	0.0%	0.0%	0.0%	0.0%	0.0%	0.0%	0.0%	0.0%	0.0%	0.0%	0.0%	0.0%	0.0%	0.0%	0.0%	0.0%	0.0%	0.0%	0.0%	0.0%	0.0%	0.0%	0.0%	0.0%	0.0%	0.0%	0.0%	0.0%
Buses	0	0	0	0	0	0	0	3	10	1	0	14	0	0	2	4	2	0	8	0	0	1	9	1	0	11	0	0	33
% Buses	0.0%	0.0%	0.0%	0.0%	0.0%	0.0%	0.0%	3.1%	2.3%	6.7%	0.0%	0.0%	0.0%	0.0%	5.7%	10.5%	33.3%	0.0%	0.0%	0.0%	0.0%	8.3%	2.7%	2.2%	0.0%	0.0%	0.0%	0.0%	3.3%
Pedestrians	0	0	0	0	9	5	0	0	0	0	0	1	1	1	0	0	0	0	2	0	0	0	0	0	0	0	12	6	0
% Pedestrians	0.0%	0.0%	0.0%	0.0%	100.0%	83.3%	0.0%	0.0%	0.0%	0.0%	0.0%	100.0%	100.0%	0.0%	0.0%	0.0%	0.0%	0.0%	0.0%	0.0%	0.0%	100.0%	100.0%	0.0%	100.0%	85.7%	0.0%		
Bicycles on Crosswalk	0	0	0	0	0	1	0	0	0	0	0	0	0	0	0	0	0	0	0	1	0	0	0	0	0	0	1	0	0
% Bicycles on Crosswalk	0.0%	0.0%	0.0%	0.0%	0.0%	0.0%	16.7%	0.0%	0.0%	0.0%	0.0%	0.0%	0.0%	0.0%	0.0%	0.0%	0.0%	0.0%	0.0%	0.0%	100.0%	0.0%	0.0%	0.0%	0.0%	0.0%	0.0%	14.3%	0.0%

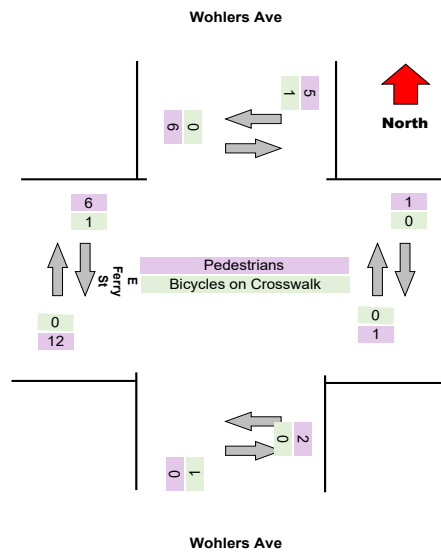
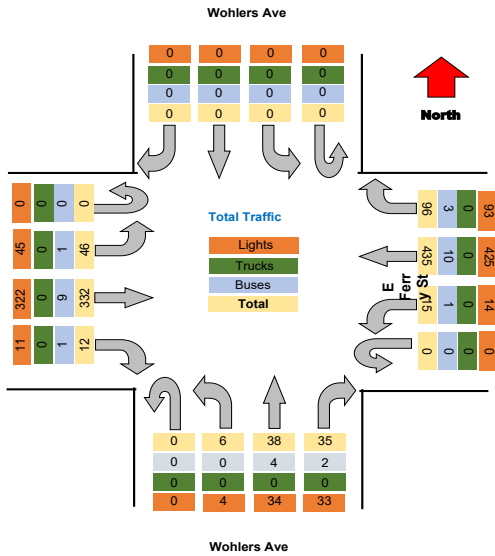



Project : VBH Malta NY  
 Site : Site 4  
 Location : 42.948550, -73.790036  
 Survey Date : 2021-04-28, Wednesday

### Turning Movement Data Plot

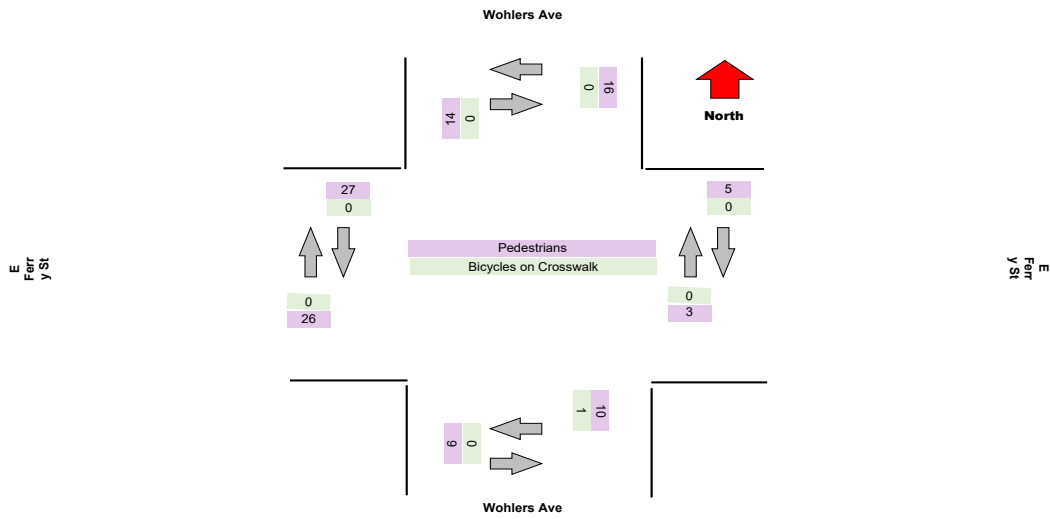
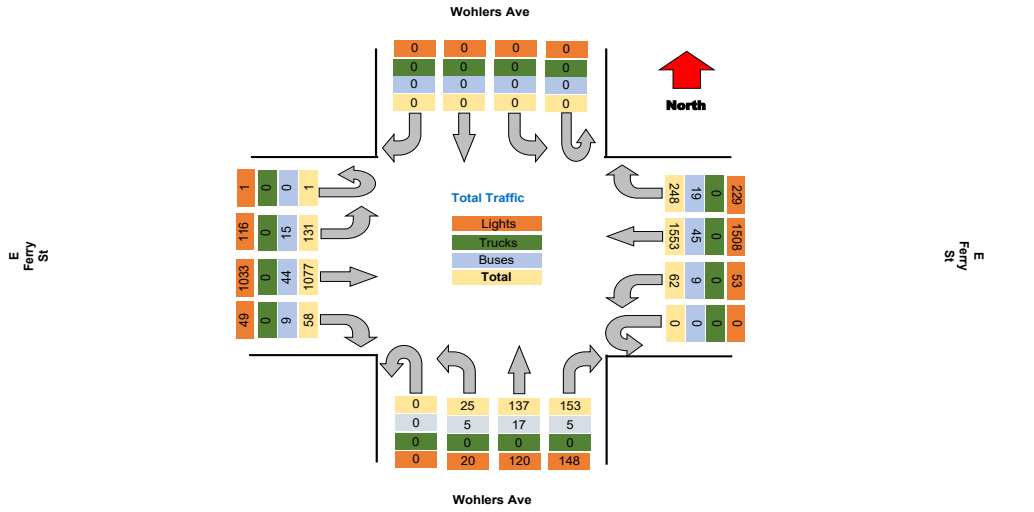

Project : VBH Malta NY  
Site : Site 4  
Location : 42.948550, -73.790036

TSTData.com

Survey Date : 2021-04-28, Wednesday

### Turning Movement Peak Hour Data (AM)

7:30:00 AM

Leg Direction	Wohlers Ave								E Ferry St								Wohlers Ave								E Ferry St								Total
	Southbound				Westbound				Northbound				Eastbound				Northbound				Eastbound												
Start Time	Right	Thru	Left	U-Turn	App Total	Peds CW	Peds CCW		Right	Thru	Left	U-Turn	App Total	Peds CW	Peds CCW		Right	Thru	Left	U-Turn	App Total	Peds CW	Peds CCW		Right	Thru	Left	U-Turn	App Total	Peds CW	Peds CCW		
7:30:00 AM	0	0	0	0	0	0	0		11	114	3	0	128	0	0		9	5	1	0	15	0	1		0	59	4	0	63	0	1		206
7:45:00 AM	0	0	0	0	0	0	0		10	149	3	0	162	0	0		9	6	5	0	20	0	0		1	85	4	0	90	0	0		272
8:00:00 AM	0	0	0	0	0	0	0		15	122	9	0	146	0	0		12	7	1	0	20	1	0		1	75	3	0	79	1	1		245
8:15:00 AM	0	0	0	0	0	0	0		17	83	10	0	110	0	0		8	3	0	0	11	1	0		2	53	10	0	65	2	1		186
<b>Grand Total</b>	0	0	0	0	0	0	0		53	468	25	0	545	0	0		38	21	7	0	66	2	1		4	272	21	0	297	3	3		909
% Approach	#DIV/0!	#DIV/0!	#DIV/0!	#DIV/0!	0.0%	0.0%	0.0%		9.7%	85.7%	4.6%	0.0%	0.0%	0.0%	0.0%		57.6%	31.8%	10.6%	0.0%	0.0%	0.0%	0.0%		1.3%	91.6%	7.1%	0.0%	0.0%	0.0%	0.0%		
% Total	0.0%	0.0%	0.0%	0.0%	0.0%	0.0%	0.0%		5.8%	51.5%	2.8%	0.0%	60.1%	0.0%	0.0%		4.2%	2.3%	0.8%	0.0%	7.3%	0.0%	0.0%		0.4%	29.9%	2.3%	0.0%	32.7%	0.0%	0.0%		
PHF	0.000	0.000	0.000	0.000	0.000	0.000	0.000		0.779	0.785	0.625	0.000	0.843	0.000	0.000		0.792	0.750	0.350	0.000	0.825	0.000	0.000		0.500	0.800	0.525	0.000	0.825	0.000	0.000		0.835
Lights	0	0	0	0	0	0	0		47	447	24	0	518	0	0		36	15	5	0	56	0	0		4	256	15	0	275	0	0		849
% Lights	0.0%	0.0%	0.0%	0.0%	0.0%	0.0%	0.0%		88.7%	95.5%	96.0%	0.0%	94.9%	0.0%	0.0%		84.7%	71.4%	71.4%	0.0%	84.8%	0.0%	0.0%		100.0%	94.1%	71.4%	0.0%	92.6%	0.0%	0.0%		93.4%
Trucks	0	0	0	0	0	0	0		0	0	0	0	0	0	0		0	0	0	0	0	0	0		0	0	0	0	0	0	0		0
% Trucks	0.0%	0.0%	0.0%	0.0%	0.0%	0.0%	0.0%		0.0%	0.0%	0.0%	0.0%	0.0%	0.0%	0.0%		0.0%	0.0%	0.0%	0.0%	0.0%	0.0%	0.0%		0.0%	0.0%	0.0%	0.0%	0.0%	0.0%	0.0%		0.0%
Buses	0	0	0	0	0	0	0		6	21	1	0	28	0	0		2	6	2	0	10	0	0		0	16	6	0	22	0	0		60
% Buses	0.0%	0.0%	0.0%	0.0%	0.0%	0.0%	0.0%		11.3%	4.5%	4.0%	0.0%	0.0%	0.0%	0.0%		5.3%	28.6%	28.6%	0.0%	0.0%	0.0%	0.0%		0.0%	5.9%	28.6%	0.0%	0.0%	0.0%	0.0%		6.6%
Pedestrians	0	0	0	0	0	0	0		0	0	0	0	0	0	0		0	0	0	0	2	1	0		0	0	0	0	3	3	0		0
% Pedestrians	0.0%	0.0%	0.0%	0.0%	0.0%	0.0%	0.0%		0.0%	0.0%	0.0%	0.0%	0.0%	0.0%	0.0%		0.0%	0.0%	0.0%	0.0%	0.0%	100.0%	100.0%		0.0%	0.0%	0.0%	0.0%	100.0%	100.0%	0.0%		0.0%
Bicycles on Crosswalk	0	0	0	0	0	0	0		0	0	0	0	0	0	0		0	0	0	0	0	0	0		0	0	0	0	0	0	0		0
% Bicycles on Crosswalk	0.0%	0.0%	0.0%	0.0%	0.0%	0.0%	0.0%		0.0%	0.0%	0.0%	0.0%	0.0%	0.0%	0.0%		0.0%	0.0%	0.0%	0.0%	0.0%	0.0%	0.0%		0.0%	0.0%	0.0%	0.0%	0.0%	0.0%	0.0%		0.0%

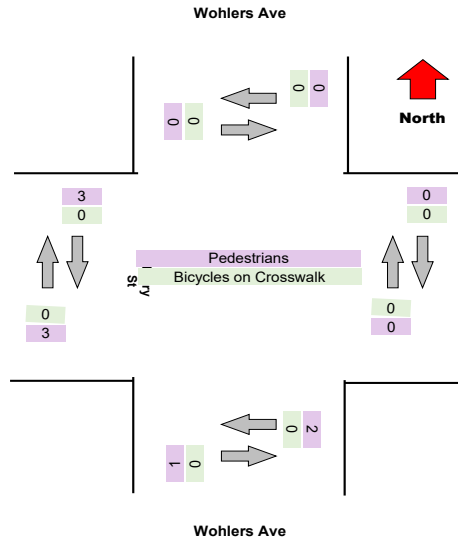
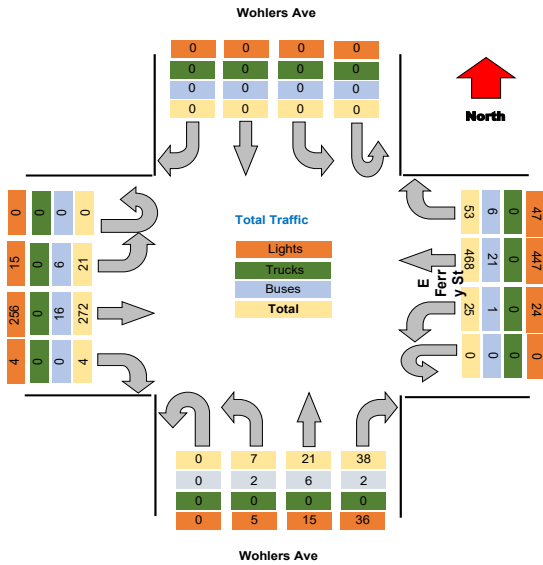

**Turning Movement Peak Hour Data (PM)**

4:30:00 PM

Leg Direction	Wohlers Ave										E Ferry St										Wohlers Ave										E Ferry St										Total
	Southbound					Westbound					Northbound					Eastbound																									
	Right	Thru	Left	U-Turn	App Total	Right	Thru	Left	U-Turn	App Total	Right	Thru	Left	U-Turn	App Total	Right	Thru	Left	U-Turn	App Total																					
4:30:00 PM	0	0	0	0	0	19	108	7	0	134	17	18	3	0	38	6	105	18	0	129	1	1	1	0	3	301															
4:45:00 PM	0	0	0	0	0	11	119	2	0	132	18	11	0	0	29	3	82	14	0	99	5	1	1	0	7	260															
5:00:00 PM	0	0	0	0	0	28	101	1	0	130	7	15	4	0	26	2	81	8	0	91	10	5	1	0	16	248															
5:15:00 PM	0	0	0	0	0	28	124	4	0	156	11	19	2	0	32	4	81	13	0	98	0	7	1	0	8	277															
Grand Total	0	0	0	0	0	85	452	14	0	552	53	54	9	0	116	15	349	53	0	418	15	14	4	0	33	1086															
% Approach	#DIV/0!	#DIV/0!	#DIV/0!	#DIV/0!	0.0%	15.6%	81.9%	2.5%	0.0%	0.0%	45.7%	46.6%	7.8%	0.0%	0.0%	3.8%	83.5%	12.7%	0.0%	0.0%	0.0%	0.0%	0.0%	0.0%	0.0%																
% Total	0.0%	0.0%	0.0%	0.0%	0.0%	7.9%	41.6%	1.3%	0.0%	50.8%	4.9%	5.0%	0.8%	0.0%	10.7%	1.5%	32.1%	4.9%	0.0%	38.5%	0.0%	0.0%	0.0%	0.0%	0.0%	0.902															
PHF	0.000	0.000	0.000	0.000	0.000	0.768	0.911	0.500	0.000	0.885	0.736	0.750	0.563	0.000	0.763	0.667	0.831	0.736	0.000	0.810	0.000	0.000	0.000	0.000	0.000	0.902															
Lights	0	0	0	0	0	82	444	12	0	538	51	50	7	0	108	14	341	50	0	405	0	0	0	0	0	1051															
% Lights	0.0%	0.0%	0.0%	0.0%	0.0%	85.3%	98.2%	85.7%	0.0%	97.5%	86.2%	92.6%	77.8%	0.0%	93.1%	87.5%	97.7%	94.3%	0.0%	96.9%	0.0%	0.0%	0.0%	0.0%	0.0%	96.8%															
Trucks	0	0	0	0	0	0	0	0	0	0	0	0	0	0	0	0	0	0	0	0	0	0	0	0	0	0															
% Trucks	0.0%	0.0%	0.0%	0.0%	0.0%	0.0%	0.0%	0.0%	0.0%	0.0%	0.0%	0.0%	0.0%	0.0%	0.0%	0.0%	0.0%	0.0%	0.0%	0.0%	0.0%	0.0%	0.0%	0.0%	0.0%	0.0%															
Buses	0	0	0	0	0	4	8	2	0	14	2	4	2	0	8	2	8	3	0	13	0	0	0	0	0	35															
% Buses	0.0%	0.0%	0.0%	0.0%	0.0%	4.7%	1.8%	14.3%	0.0%	0.0%	3.8%	7.4%	22.2%	0.0%	0.0%	12.5%	2.3%	5.7%	0.0%	0.0%	0.0%	0.0%	0.0%	0.0%	0.0%	3.2%															
Pedestrians	0	0	0	0	8	0	0	0	0	0	0	0	0	0	4	0	0	0	0	0	0	0	0	0	16	14															
% Pedestrians	0.0%	0.0%	0.0%	0.0%	100.0%	0.0%	0.0%	0.0%	0.0%	0.0%	0.0%	0.0%	0.0%	0.0%	0.0%	0.0%	0.0%	0.0%	0.0%	0.0%	0.0%	0.0%	0.0%	0.0%	100.0%	0.0%															
Bicycles on Crosswalk	0	0	0	0	0	0	0	0	0	0	0	0	0	0	0	0	0	0	0	0	0	0	0	0	0	0															
% Bicycles on Crosswalk	0.0%	0.0%	0.0%	0.0%	0.0%	0.0%	0.0%	0.0%	0.0%	0.0%	0.0%	0.0%	0.0%	0.0%	0.0%	0.0%	0.0%	0.0%	0.0%	0.0%	0.0%	0.0%	0.0%	0.0%	0.0%	0.0%															

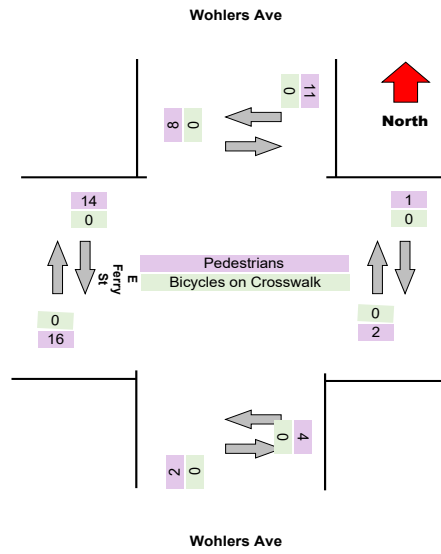
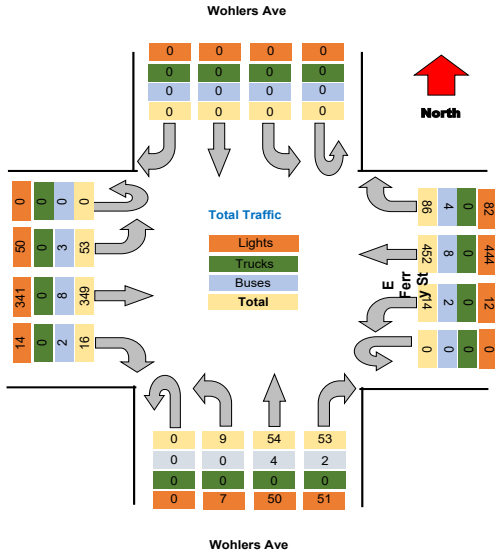





Project : VBH Malta NY  
 Site : Site 4  
 Location : 42.948550, -73.790036  
 Survey Date : 2021-04-28, Wednesday

### Turning Movement Data Plot

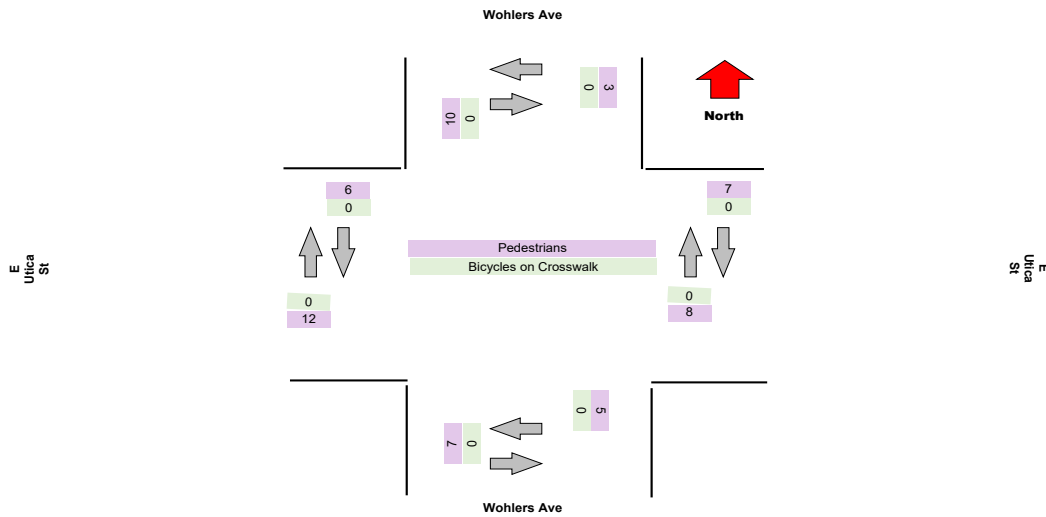
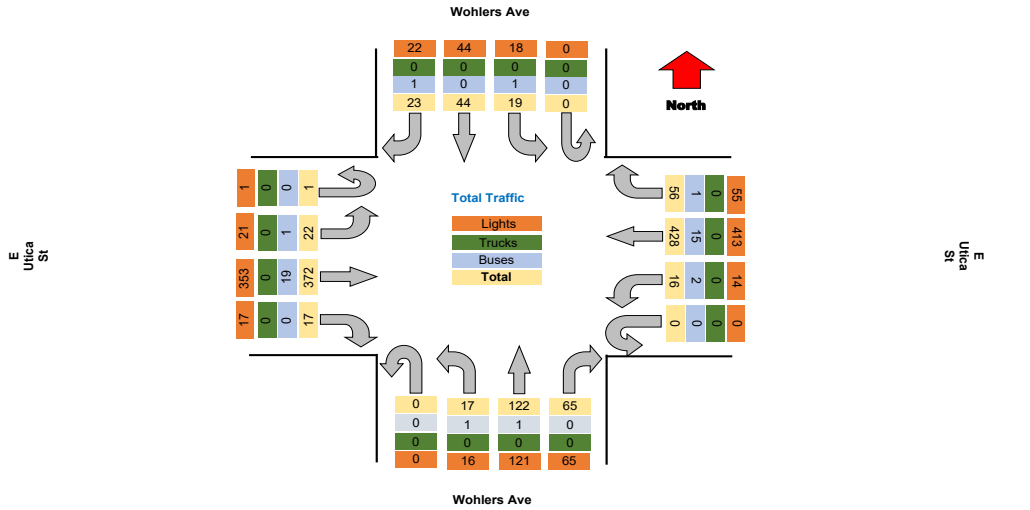

Project : VBH Malta NY  
Site : Site 4  
Location : 42.948550, -73.790036

TSTData.com

Survey Date : 2021-04-28, Wednesday

**Turning Movement Peak Hour Data (AM)**

7:30:00 AM

Leg Direction	Wohlers Ave							E Utica St							Wohlers Ave							E Utica St							Total
	Southbound			Westbound				Northbound			Eastbound				Northbound			Eastbound											
Start Time	Right	Thru	Left	U-Turn	App Total	Peds CW	Peds CCW	Right	Thru	Left	U-Turn	App Total	Peds CW	Peds CCW	Right	Thru	Left	U-Turn	App Total	Peds CW	Peds CCW	Right	Thru	Left	U-Turn	App Total	Peds CW	Peds CCW	
7:30:00 AM	1	1	0	0	2	0	0	0	14	0	0	14	0	0	3	5	0	0	8	0	0	0	12	0	0	12	0	0	36
7:45:00 AM	0	2	1	0	3	0	0	4	19	1	0	24	0	0	1	5	1	0	7	0	1	0	16	0	0	16	0	0	50
8:00:00 AM	0	2	0	0	2	0	0	5	26	1	0	32	0	0	4	1	1	0	7	0	0	1	21	1	0	23	2	1	64
8:15:00 AM	0	0	1	0	1	0	0	1	24	1	0	26	0	0	8	4	0	0	12	1	1	1	11	1	0	13	0	1	52
<b>Grand Total</b>	<b>1</b>	<b>5</b>	<b>2</b>	<b>0</b>	<b>8</b>	<b>0</b>	<b>0</b>	<b>10</b>	<b>83</b>	<b>3</b>	<b>0</b>	<b>96</b>	<b>0</b>	<b>0</b>	<b>16</b>	<b>15</b>	<b>2</b>	<b>0</b>	<b>33</b>	<b>1</b>	<b>2</b>	<b>2</b>	<b>60</b>	<b>2</b>	<b>0</b>	<b>64</b>	<b>2</b>	<b>2</b>	<b>202</b>
% Approach	12.5%	62.5%	25.0%	0.0%	0.0%	0.0%	0.0%	10.4%	86.6%	3.1%	0.0%	0.0%	0.0%	0.0%	47.1%	44.1%	5.9%	0.0%	0.0%	0.0%	0.0%	0.0%	3.1%	93.8%	3.1%	0.0%	0.0%	0.0%	0.0%
% Total	0.5%	2.5%	1.0%	0.0%	4.0%	0.0%	0.0%	5.0%	41.1%	1.5%	0.0%	47.5%	0.0%	0.0%	7.9%	7.4%	1.0%	0.0%	16.8%	0.0%	0.0%	1.0%	29.7%	1.0%	0.0%	31.7%	0.0%	0.0%	
PHF	0.250	0.625	0.500	0.000	0.667	0.000	0.000	0.500	0.788	0.750	0.000	0.750	0.000	0.000	0.500	0.750	0.500	0.000	0.708	0.000	0.000	0.500	0.714	0.500	0.000	0.696	0.000	0.000	0.789
Lights	1	5	2	0	8	0	0	9	79	3	0	91	0	0	16	15	2	0	33	0	0	2	55	2	0	59	0	0	191
% Lights	100.0%	100.0%	100.0%	0.0%	100.0%	0.0%	0.0%	80.0%	95.2%	100.0%	0.0%	94.8%	0.0%	0.0%	100.0%	100.0%	100.0%	0.0%	97.1%	0.0%	0.0%	100.0%	91.7%	100.0%	0.0%	92.2%	0.0%	0.0%	94.6%
Trucks	0	0	0	0	0	0	0	0	0	0	0	0	0	0	0	0	0	0	0	0	0	0	0	0	0	0	0	0	0
% Trucks	0.0%	0.0%	0.0%	0.0%	0.0%	0.0%	0.0%	0.0%	0.0%	0.0%	0.0%	0.0%	0.0%	0.0%	0.0%	0.0%	0.0%	0.0%	0.0%	0.0%	0.0%	0.0%	0.0%	0.0%	0.0%	0.0%	0.0%	0.0%	0.0%
Buses	0	0	0	0	0	0	0	1	4	0	0	5	0	0	0	0	0	0	0	0	0	0	5	0	0	5	0	0	10
% Buses	0.0%	0.0%	0.0%	0.0%	0.0%	0.0%	0.0%	10.0%	4.8%	0.0%	0.0%	5.0%	0.0%	0.0%	0.0%	0.0%	0.0%	0.0%	0.0%	0.0%	0.0%	0.0%	8.3%	0.0%	0.0%	0.0%	0.0%	0.0%	5.0%
Pedestrians	0	0	0	0	0	0	0	0	0	0	0	0	1	2	0	0	0	0	0	1	2	0	0	0	0	0	2	2	0
% Pedestrians	0.0%	0.0%	0.0%	0.0%	0.0%	0.0%	0.0%	0.0%	0.0%	0.0%	0.0%	0.0%	0.0%	100.0%	0.0%	0.0%	0.0%	0.0%	0.0%	0.0%	100.0%	0.0%	0.0%	0.0%	0.0%	0.0%	0.0%	100.0%	100.0%
Bicycles on Crosswalk	0	0	0	0	0	0	0	0	0	0	0	0	0	0	0	0	0	0	0	0	0	0	0	0	0	0	0	0	0
% Bicycles on Crosswalk	0.0%	0.0%	0.0%	0.0%	0.0%	0.0%	0.0%	0.0%	0.0%	0.0%	0.0%	0.0%	0.0%	0.0%	0.0%	0.0%	0.0%	0.0%	0.0%	0.0%	0.0%	0.0%	0.0%	0.0%	0.0%	0.0%	0.0%	0.0%	0.0%

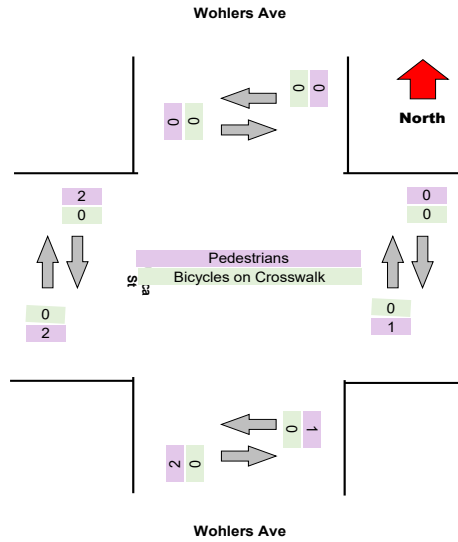
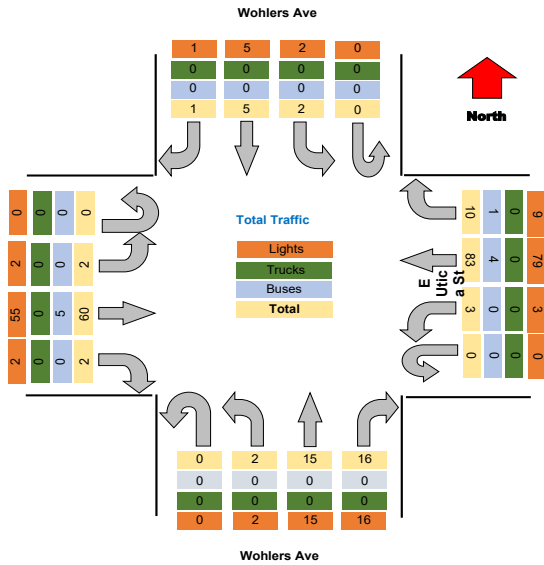

**Turning Movement Peak Hour Data (PM)**

4:15:00 PM

Leg Direction	Wohlers Ave										E Ulica St										Total
	Southbound					Westbound					Northbound					Eastbound					
	Right	Thru	Left	U-Turn	App Total	Right	Thru	Left	U-Turn	App Total	Right	Thru	Left	U-Turn	App Total	Right	Thru	Left	U-Turn	App Total	
4:15:00 PM	7	4	3	0	14	5	33	1	0	39	4	12	2	0	18	1	30	2	0	33	104
4:30:00 PM	4	5	0	0	9	4	32	1	0	37	4	13	4	0	21	1	0	0	0	1	112
4:45:00 PM	2	4	3	0	9	9	42	0	0	51	5	6	2	0	13	0	0	0	0	0	110
5:00:00 PM	2	4	1	0	7	3	45	4	0	52	5	9	2	0	16	0	39	2	1	42	117
<b>Grand Total</b>	15	17	7	0	39	21	152	6	0	179	18	40	10	0	68	3	144	7	1	155	443
% Approach	38.5%	43.6%	17.9%	0.0%	0.0%	11.7%	84.9%	3.4%	0.0%	0.0%	26.5%	58.8%	14.7%	0.0%	0.0%	3.2%	91.7%	4.5%	0.6%	0.0%	
% Total	3.4%	3.8%	1.6%	0.0%	8.8%	4.7%	34.3%	1.4%	0.0%	40.4%	4.1%	9.0%	2.3%	0.0%	15.3%	1.1%	32.5%	1.6%	0.2%	35.4%	
PHF	0.536	0.850	0.583	0.000	0.696	0.583	0.844	0.375	0.000	0.861	0.900	0.769	0.625	0.000	0.810	0.625	0.857	0.875	0.250	0.872	0.947
Lights	14	17	7	0	38	21	149	6	0	176	18	40	10	0	68	5	140	7	1	153	435
% Lights	83.3%	100.0%	100.0%	0.0%	97.4%	100.0%	98.0%	100.0%	0.0%	98.3%	100.0%	100.0%	100.0%	0.0%	100.0%	100.0%	97.2%	100.0%	100.0%	97.5%	98.2%
Trucks	0	0	0	0	0	0	0	0	0	0	0	0	0	0	0	0	0	0	0	0	0
% Trucks	0.0%	0.0%	0.0%	0.0%	0.0%	0.0%	0.0%	0.0%	0.0%	0.0%	0.0%	0.0%	0.0%	0.0%	0.0%	0.0%	0.0%	0.0%	0.0%	0.0%	0.0%
Buses	1	0	0	0	1	0	3	0	0	3	0	0	0	0	0	0	4	0	0	4	8
% Buses	6.7%	0.0%	0.0%	0.0%	0.0%	0.0%	2.0%	0.0%	0.0%	0.0%	0.0%	0.0%	0.0%	0.0%	0.0%	0.0%	2.8%	0.0%	0.0%	0.0%	1.8%
Pedestrians	0	0	0	0	0	0	2	0	0	2	0	0	0	0	0	0	0	0	0	0	2
% Pedestrians	0.0%	0.0%	0.0%	0.0%	0.0%	0.0%	0.0%	0.0%	0.0%	0.0%	0.0%	0.0%	0.0%	0.0%	0.0%	0.0%	0.0%	0.0%	0.0%	0.0%	0.0%
Bicycles on Crosswalk	0	0	0	0	0	0	0	0	0	0	0	0	0	0	0	0	0	0	0	0	0
% Bicycles on Crosswalk	0.0%	0.0%	0.0%	0.0%	0.0%	0.0%	0.0%	0.0%	0.0%	0.0%	0.0%	0.0%	0.0%	0.0%	0.0%	0.0%	0.0%	0.0%	0.0%	0.0%	0.0%

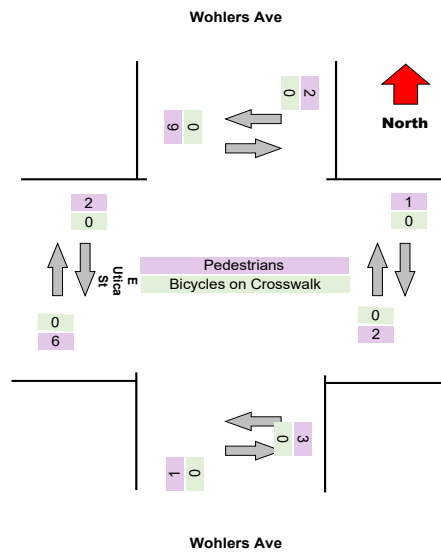
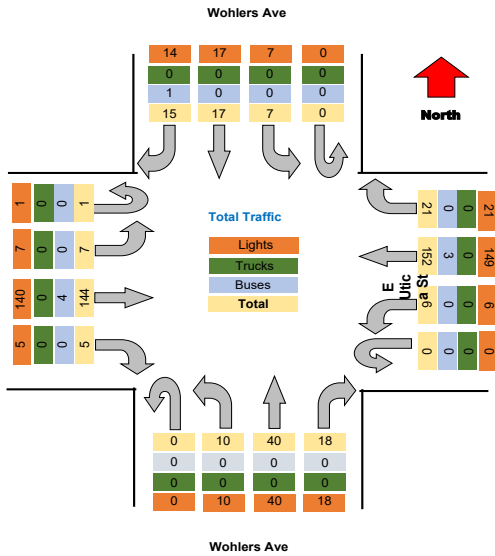

Project : VBH Malta NY  
 Site : Site 4  
 Location : 42.948550, -73.790036

TSTData.com

Survey Date : 2021-04-28, Wednesday

Project	LaBella
Project Code	LaBella
Site Name	40
Legs and Movements	All Processed Legs & Move
Bin Size	15 minutes
Survey Date	2021-11-03, Wednesday
Location	40
Latitude and Longitude	42.911066, -78.848082

	Start	End	PHF
Forced Peak AM	2021/11/03 07:30:00	2021/11/03 08:30:00	0.89
Forced Peak PM	2021/11/03 16:30:00	2021/11/03 17:30:00	0.97
AM Peak	2021/11/03 07:30:00	2021/11/03 08:30:00	0.89
PM Peak	2021/11/03 16:15:00	2021/11/03 17:15:00	0.83

### Turning Movement Data

Leg Direction	Wohlers Ave										E Utica St										Wohlers Ave										E Utica St										Total
	Southbound					Westbound					Northbound					Eastbound					Southbound					Westbound					Northbound					Eastbound					
	Right	Thru	Left	U-Turn	App Total	Right	Thru	Left	U-Turn	App Total	Right	Thru	Left	U-Turn	App Total	Right	Thru	Left	U-Turn	App Total	Right	Thru	Left	U-Turn	App Total	Right	Thru	Left	U-Turn	App Total	Right	Thru	Left	U-Turn	App Total	Right	Thru	Left	U-Turn	App Total	
6:30:00 AM	0	1	0	0	1	0	0	0	0	0	1	10	0	0	11	0	0	0	0	0	4	1	0	0	5	0	0	0	0	0	0	9	0	0	9	0	0	0	0	0	26
6:45:00 AM	1	3	0	0	4	1	15	1	0	17	0	0	0	0	0	0	2	0	0	2	3	2	2	2	9	1	9	2	0	12	0	0	0	0	0	1	6	0	0	7	38
Hourly Total	1	4	0	0	5	2	25	1	0	28	0	0	0	0	0	4	3	0	0	7	6	2	2	2	12	1	18	2	0	21	0	0	0	0	0	2	15	0	0	17	49
7:00:00 AM	1	2	2	0	5	2	18	2	0	22	0	0	0	0	0	3	3	1	0	7	0	0	0	0	0	1	14	0	0	15	0	0	0	0	0	1	14	0	0	15	49
7:15:00 AM	0	2	1	0	3	3	15	0	0	18	0	0	0	0	0	6	6	5	0	17	0	0	0	0	0	2	8	1	0	11	0	0	0	0	0	2	11	0	0	13	49
7:30:00 AM	2	2	0	0	4	4	22	1	0	28	0	1	0	0	1	4	12	1	0	17	0	0	0	0	0	0	15	5	0	20	1	0	0	0	1	21	70				
7:45:00 AM	1	2	1	0	4	5	33	1	0	39	4	1	0	0	5	3	3	1	0	7	2	0	0	0	2	2	26	3	0	31	0	0	0	0	0	2	26	3	0	31	86
Hourly Total	4	8	4	0	16	14	88	4	0	107	4	2	0	0	6	16	24	8	0	48	2	0	0	0	2	5	63	9	0	77	1	2	0	0	3	254					
8:00:00 AM	0	4	0	0	4	2	33	1	0	36	0	1	0	0	1	3	4	0	0	7	0	0	0	0	0	4	23	3	0	30	0	0	0	0	0	4	23	3	0	30	78
8:15:00 AM	1	2	0	0	3	4	29	1	0	34	0	1	0	0	1	5	6	0	0	11	0	0	0	0	0	1	23	0	0	24	0	0	0	0	0	1	23	0	0	24	73
Hourly Total	1	6	0	0	7	6	62	2	0	70	0	2	0	0	2	8	10	0	0	18	0	0	0	0	0	5	46	3	0	54	0	0	0	0	0	6	54	3	0	63	151
4:00:00 PM	3	4	9	0	16	3	35	1	0	39	0	2	0	0	2	6	13	2	0	21	0	0	0	0	0	4	43	6	0	53	4	0	0	0	4	128					
4:15:00 PM	3	7	3	0	13	0	0	0	0	0	11	38	6	0	55	0	0	0	0	0	2	13	2	0	17	0	0	0	0	0	4	40	6	0	50	0	0	0	0	0	135
4:30:00 PM	3	4	2	0	9	5	31	1	0	37	0	1	0	0	1	10	8	4	0	22	0	1	0	0	1	2	36	2	0	40	3	1	0	0	4	168					
4:45:00 PM	1	3	1	0	5	9	35	4	0	48	2	1	0	0	3	6	11	3	0	20	0	2	0	0	2	0	32	0	0	32	1	0	0	0	1	105					
Hourly Total	10	18	15	0	43	11	4	27	139	12	0	178	2	4	24	45	11	0	80	0	3	10	151	14	0	175	9	1	4	0	14	476									
5:00:00 PM	2	7	1	0	10	0	0	0	0	0	3	27	1	0	31	0	0	0	0	0	3	7	7	0	17	0	1	0	0	1	0	40	4	0	44	1	0	0	0	1	102
5:15:00 PM	1	1	2	0	4	0	0	0	0	0	6	33	3	0	42	0	0	0	0	0	5	10	2	0	17	2	0	0	0	2	3	40	0	0	43	0	0	0	0	0	106
5:30:00 PM	1	3	1	0	5	0	0	0	0	0	4	40	1	0	45	0	0	0	0	0	6	17	0	0	23	0	0	0	0	0	1	29	4	0	34	0	0	0	0	0	107
5:45:00 PM	1	5	3	0	9	0	0	0	0	0	6	18	3	0	27	0	0	0	0	0	8	11	0	0	19	0	0	0	0	0	1	23	3	0	27	0	0	0	0	0	82
Hourly Total	5	16	7	0	28	0	1	19	118	8	0	145	0	0	22	45	9	0	76	2	1	5	132	11	0	148	1	0	4	0	5	397									
Grand Total	21	52	26	0	99	17	6	68	432	27	0	528	6	9	74	127	28	0	238	6	7	26	410	39	0	475	11	4	1340												
% Approach	21.2%	52.5%	26.3%	0.0%	0.0%	0.0%	0.0%	12.9%	81.8%	5.1%	0.0%	0.0%	0.0%	0.0%	31.1%	53.4%	11.8%	0.0%	0.0%	0.0%	0.0%	5.5%	86.3%	8.2%	0.0%	0.0%	0.0%	0.0%	0.0%	0.0%	0.0%	0.0%	0.0%	0.0%	0.0%	0.0%	0.0%				
% Total	1.6%	3.8%	1.9%	0.0%	7.4%	0.0%	0.0%	5.1%	32.2%	2.0%	0.0%	39.4%	0.0%	0.0%	5.5%	9.5%	2.1%	0.0%	17.8%	0.0%	0.0%	1.8%	30.6%	2.9%	0.0%	35.4%	0.0%	0.0%	0.0%	0.0%	0.0%	0.0%									
Lights	17	47	17	0	81	0	0	65	404	25	0	494	0	0	73	120	22	0	215	0	0	22	379	33	0	434	0	0	1224												
% Lights	81.0%	90.4%	65.4%	0.0%	81.8%	0.0%	0.0%	55.9%	93.5%	92.6%	0.0%	93.6%	0.0%	0.0%	86.6%	84.6%	78.6%	0.0%	90.3%	0.0%	0.0%	84.6%	92.4%	84.6%	0.0%	91.4%	0.0%	0.0%	91.3%												
Trucks	0	0	0	0	0	0	0	0	0	0	0	0	0	0	0	0	0	0	0	0	0	0	1	0	0	1	0	0	1												
% Trucks	0.0%	0.0%	0.0%	0.0%	0.0%	0.0%	0.0%	0.0%	0.0%	0.0%	0.0%	0.0%	0.0%	0.0%	0.0%	0.0%	0.0%	0.0%	0.0%	0.0%	0.0%	0.0%	0.2%	0.0%	0.0%	0.2%	0.0%	0.0%	0.1%												
Buses	4	5	9	0	18	0	0	3	28	2	0	33	0	0	1	7	6	0	14	0	0	4	30	6	0	40	0	0	106												
% Buses	19.0%	9.6%	34.6%	0.0%	0.0%	0.0%	0.0%	0.0%	6.5%	7.4%	0.0%	0.0%	0.0%	0.0%	1.4%	5.5%	21.4%	0.0%	0.0%	0.0%	0.0%	15.4%	7.3%	15.4%	0.0%	0.0%	0.0%	0.0%	7.8%												
Pedestrians	0	0	0	0	0	0	0	0	0	0	0	0	0	0	0	0	0	0	0	0	0	0	0	0	0	0	0	0	0												
% Pedestrians	0.0%	0.0%	0.0%	0.0%	0.0%	0.0%	0.0%	0.0%	0.0%	0.0%	0.0%	0.0%	0.0%	0.0%	0.0%	0.0%	0.0%	0.0%	0.0%	0.0%	0.0%	0.0%	0.0%	0.0%	0.0%	0.0%	0.0%	0.0%	0.0%												
Bicycles on Crosswalk	0	0	0	0	0	0	0	0	0	0	2	0	0	0	0	0	0	0	0	0	0	0	0	0	0	0	0	0	0												
% Bicycles on Crosswalk	0.0%	0.0%	0.0%	0.0%	0.0%	0.0%	0.0%	0.0%	0.0%	0.0%	0.0%	33.3%	0.0%	0.0%	0.0%	0.0%	0.0%	0.0%	0.0%	0.0%	0.0%	0.0%	0.0%	0.0%	0.0%	0.0%	0.0%	0.0%	0.0%												

Project : VBH Malta NY  
 Site : Site 4  
 Location : 42.948550, -73.790036  
 Survey Date : 2021-04-28, Wednesday

### Turning Movement Data Plot

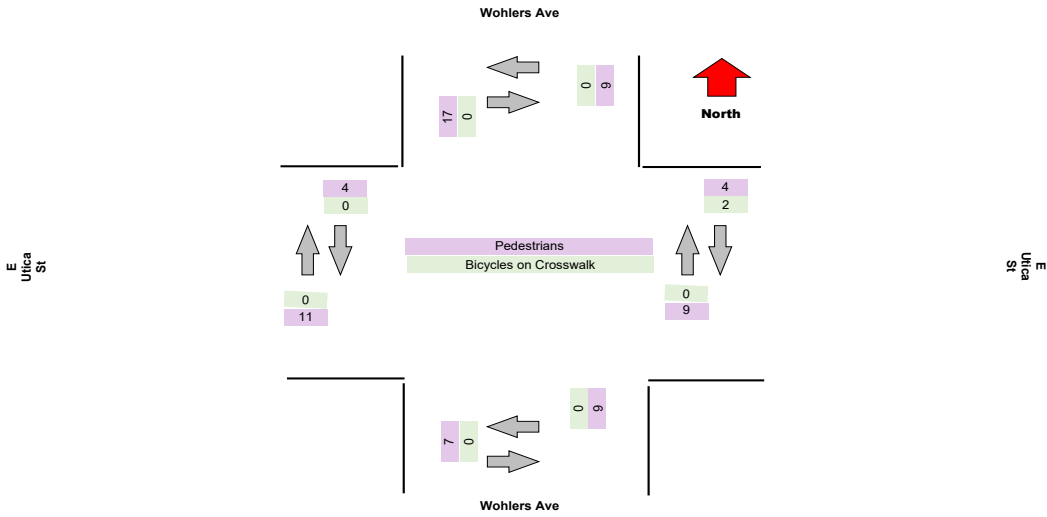
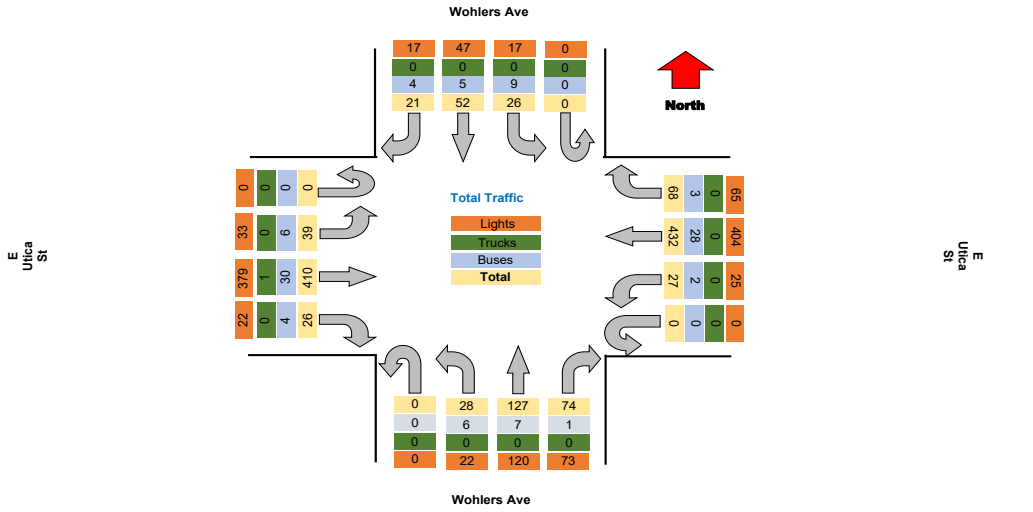

Project : VBH Malta NY  
Site : Site 4  
Location : 42.948550, -73.790036

TSTData.com

Survey Date : 2021-04-28, Wednesday

### Turning Movement Peak Hour Data (AM)

7:30:00 AM

Leg Direction	Wohlers Ave							E Ulica St							Wohlers Ave							E Ulica St							Total
	Southbound			Westbound				Northbound			Eastbound				Northbound			Eastbound											
Start Time	Right	Thru	Left	U-Turn	App Total	Peds CW	Peds CCW	Right	Thru	Left	U-Turn	App Total	Peds CW	Peds CCW	Right	Thru	Left	U-Turn	App Total	Peds CW	Peds CCW	Right	Thru	Left	U-Turn	App Total	Peds CW	Peds CCW	
7:30:00 AM	2	2	0	0	4	1	1	4	22	1	0	28	0	1	4	12	1	0	18	0	0	0	15	5	0	20	1	0	70
7:45:00 AM	1	2	1	0	4	0	0	5	33	1	0	39	4	1	3	3	1	0	12	2	0	2	26	3	0	31	0	1	86
8:00:00 AM	0	4	0	0	4	1	0	2	33	1	0	36	0	1	3	4	0	0	8	0	1	4	23	3	0	30	0	0	78
8:15:00 AM	1	2	0	0	3	1	0	4	29	1	0	34	0	1	5	5	0	0	12	0	0	1	23	0	0	24	0	0	73
Grand Total	4	10	1	0	15	3	1	15	117	4	0	137	4	1	15	25	2	0	50	2	1	7	87	11	0	105	1	1	397
% Approach	26.7%	66.7%	6.7%	0.0%	0.0%	0.0%	0.0%	10.9%	85.4%	2.9%	0.0%	0.0%	0.0%	0.0%	30.0%	50.0%	4.0%	0.0%	0.0%	0.0%	0.0%	6.7%	82.9%	10.5%	0.0%	0.0%	0.0%	0.0%	0.0%
% Total	1.3%	3.3%	0.3%	0.0%	4.9%	0.0%	0.0%	4.9%	38.1%	1.3%	0.0%	44.6%	0.0%	0.0%	4.9%	8.1%	0.7%	0.0%	16.3%	0.0%	0.0%	2.3%	28.3%	3.6%	0.0%	34.2%	0.0%	0.0%	0.0%
PHF	0.500	0.625	0.250	0.000	0.938	0.000	0.000	0.750	0.886	1.000	0.000	0.878	0.000	0.000	0.750	0.521	0.500	0.000	0.684	0.000	0.000	0.438	0.837	0.550	0.000	0.847	0.000	0.000	0.892
Lights	4	9	1	0	14	0	0	15	107	4	0	126	0	0	15	22	1	0	38	0	0	5	76	10	0	91	0	0	269
% Lights	100.0%	90.0%	100.0%	0.0%	93.3%	0.0%	0.0%	100.0%	91.5%	100.0%	0.0%	92.0%	0.0%	0.0%	100.0%	88.0%	50.0%	0.0%	76.0%	0.0%	0.0%	71.4%	87.4%	90.9%	0.0%	86.7%	0.0%	0.0%	87.6%
Trucks	0	0	0	0	0	0	0	0	0	0	0	0	0	0	0	0	0	0	0	0	0	0	0	0	0	0	0	0	0
% Trucks	0.0%	0.0%	0.0%	0.0%	0.0%	0.0%	0.0%	0.0%	0.0%	0.0%	0.0%	0.0%	0.0%	0.0%	0.0%	0.0%	0.0%	0.0%	0.0%	0.0%	0.0%	0.0%	0.0%	0.0%	0.0%	0.0%	0.0%	0.0%	0.0%
Buses	0	1	0	0	1	0	0	0	10	0	0	10	0	0	0	3	1	0	4	0	0	2	11	1	0	14	0	0	29
% Buses	0.0%	10.0%	0.0%	0.0%	0.0%	0.0%	0.0%	0.0%	8.5%	0.0%	0.0%	0.0%	0.0%	0.0%	0.0%	12.0%	50.0%	0.0%	0.0%	0.0%	0.0%	28.6%	12.8%	9.1%	0.0%	0.0%	0.0%	0.0%	9.4%
Pedestrians	0	0	0	0	0	3	1	0	0	0	0	0	2	4	0	0	0	0	2	1	0	0	0	0	0	0	1	1	0
% Pedestrians	0.0%	0.0%	0.0%	0.0%	0.0%	100.0%	100.0%	0.0%	0.0%	0.0%	0.0%	0.0%	50.0%	100.0%	0.0%	0.0%	0.0%	0.0%	0.0%	0.0%	100.0%	100.0%	0.0%	0.0%	0.0%	0.0%	100.0%	100.0%	0.0%
Bicycles on Crosswalk	0	0	0	0	0	0	0	0	0	0	0	2	0	0	0	0	0	0	0	0	0	0	0	0	0	0	0	0	0
% Bicycles on Crosswalk	0.0%	0.0%	0.0%	0.0%	0.0%	0.0%	0.0%	0.0%	0.0%	0.0%	0.0%	0.0%	50.0%	0.0%	0.0%	0.0%	0.0%	0.0%	0.0%	0.0%	0.0%	0.0%	0.0%	0.0%	0.0%	0.0%	0.0%	0.0%	0.0%

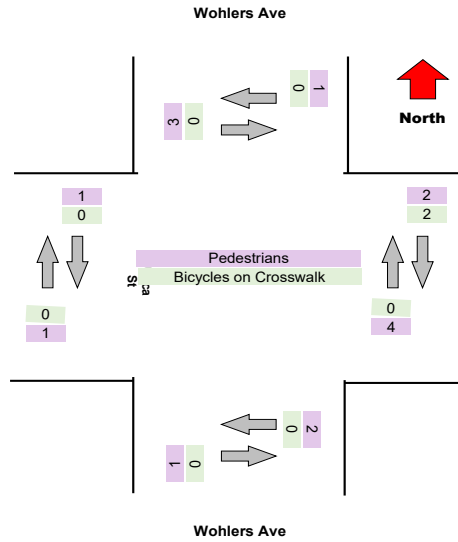
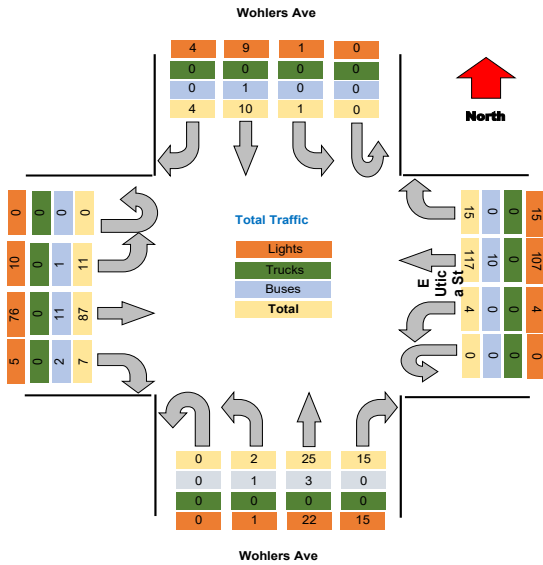

### Turning Movement Peak Hour Data (PM)

4:15:00 PM

Leg Direction	Wohlers Ave										E Utica St										Total									
	Southbound					Westbound					Northbound					Eastbound														
	Right	Thru	Left	U-Turn	App Total	Peds CW	Peds CCW	Right	Thru	Left	U-Turn	App Total	Peds CW	Peds CCW	Right	Thru	Left	U-Turn	App Total	Peds CW		Peds CCW								
4:15:00 PM	3	7	3	0	13	0	0	11	38	6	0	55	0	0	2	13	2	0	17	0	0	4	40	6	0	50	1	0	135	
4:30:00 PM	3	4	2	0	9	7	1	5	31	1	0	37	0	1	10	8	4	0	22	0	1	2	36	2	0	40	3	1	108	
4:45:00 PM	1	3	1	0	5	1	0	9	35	4	0	48	2	1	6	11	3	0	20	0	2	0	32	0	0	32	1	0	105	
5:00:00 PM	2	7	1	0	10	0	0	3	27	1	0	31	0	0	3	7	7	0	17	0	1	0	40	4	0	44	1	0	102	
<b>Grand Total</b>	9	21	7	0	37	8	1	28	131	12	0	171	2	2	21	39	16	0	76	0	4	6	148	12	0	166	3	1	450	
<b>% Approach</b>	24.3%	56.8%	18.9%	0.0%	0.0%	0.0%	0.0%	16.4%	76.6%	7.0%	0.0%	0.0%	0.0%	0.0%	27.6%	51.3%	21.1%	0.0%	0.0%	0.0%	0.0%	0.0%	3.6%	89.2%	7.2%	0.0%	0.0%	0.0%	0.0%	0.0%
<b>% Total</b>	2.0%	4.7%	1.6%	0.0%	8.2%	0.0%	0.0%	6.2%	29.1%	2.7%	0.0%	38.0%	0.0%	0.0%	4.7%	8.7%	3.6%	0.0%	16.9%	0.0%	0.0%	1.3%	32.9%	2.7%	0.0%	36.9%	0.0%	0.0%	0.0%	
<b>PHF</b>	0.750	0.750	0.583	0.000	0.712	0.000	0.000	0.636	0.882	0.500	0.000	0.777	0.000	0.000	0.525	0.750	0.571	0.000	0.864	0.000	0.000	0.375	0.925	0.500	0.000	0.830	0.000	0.000	0.833	
<b>Lights</b>	7	20	5	0	32	0	0	27	124	11	0	162	0	0	21	38	13	0	72	0	0	5	140	12	0	157	0	0	423	
<b>% Lights</b>	77.8%	95.2%	71.4%	0.0%	86.5%	0.0%	0.0%	86.4%	94.7%	91.7%	0.0%	94.7%	0.0%	0.0%	100.0%	97.4%	81.3%	0.0%	94.7%	0.0%	0.0%	83.3%	94.6%	100.0%	0.0%	94.6%	0.0%	0.0%	94.0%	
<b>Trucks</b>	0	0	0	0	0	0	0	0	0	0	0	0	0	0	0	0	0	0	0	0	0	0	1	0	0	1	0	0	1	
<b>% Trucks</b>	0.0%	0.0%	0.0%	0.0%	0.0%	0.0%	0.0%	0.0%	0.0%	0.0%	0.0%	0.0%	0.0%	0.0%	0.0%	0.0%	0.0%	0.0%	0.0%	0.0%	0.0%	0.0%	0.7%	0.0%	0.0%	0.6%	0.0%	0.0%	0.2%	
<b>Buses</b>	2	1	2	0	5	0	0	1	7	1	0	9	0	0	0	1	3	0	4	0	0	1	7	0	0	8	0	0	26	
<b>% Buses</b>	22.2%	4.8%	28.6%	0.0%	0.0%	0.0%	0.0%	3.6%	5.3%	8.3%	0.0%	0.0%	0.0%	0.0%	0.0%	2.6%	18.8%	0.0%	0.0%	0.0%	0.0%	16.7%	4.7%	0.0%	0.0%	0.0%	0.0%	5.8%		
<b>Pedestrians</b>	0	0	0	0	0	8	1	0	0	0	0	0	2	2	0	0	0	0	0	0	4	0	0	0	0	0	6	1	0	
<b>% Pedestrians</b>	0.0%	0.0%	0.0%	0.0%	0.0%	100.0%	100.0%	0.0%	0.0%	0.0%	0.0%	0.0%	100.0%	100.0%	0.0%	0.0%	0.0%	0.0%	0.0%	0.0%	100.0%	0.0%	0.0%	0.0%	0.0%	0.0%	0.0%	100.0%	100.0%	0.0%
<b>Bicycles on Crosswalk</b>	0	0	0	0	0	0	0	0	0	0	0	0	0	0	0	0	0	0	0	0	0	0	0	0	0	0	0	0	0	
<b>% Bicycles on Crosswalk</b>	0.0%	0.0%	0.0%	0.0%	0.0%	0.0%	0.0%	0.0%	0.0%	0.0%	0.0%	0.0%	0.0%	0.0%	0.0%	0.0%	0.0%	0.0%	0.0%	0.0%	0.0%	0.0%	0.0%	0.0%	0.0%	0.0%	0.0%	0.0%	0.0%	

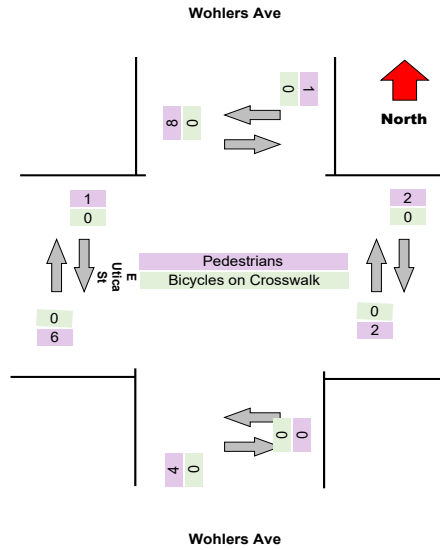
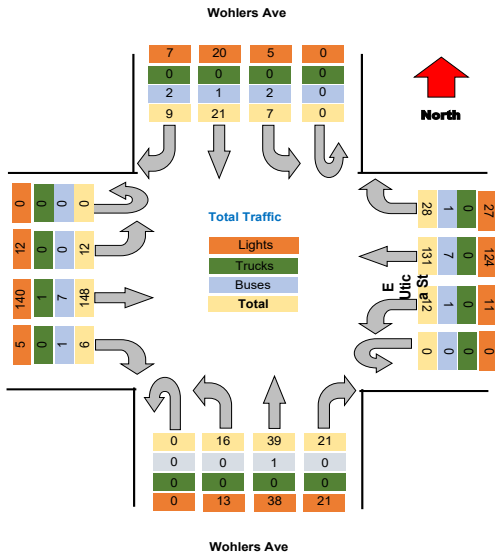

Project : VBH Malta NY  
Site : Site 4  
Location : 42.948550, -73.790036

TSTData.com

Survey Date : 2021-04-28, Wednesday

Project	LaBella
Project Code	LaBella
Site Name	40
Legs and Movements	All Processed Legs & Move
Bin Size	15 minutes
Survey Date	2021-11-04, Thursday
Location	40
Latitude and Longitude	42.911066, -78.848082

	Start	End	PHF
Forced Peak AM	2021/11/04 07:30:00	2021/11/04 08:30:00	0.91
Forced Peak PM	2021/11/04 16:30:00	2021/11/04 17:30:00	0.91
AM Peak	2021/11/04 07:30:00	2021/11/04 08:30:00	0.91
PM Peak	2021/11/04 16:15:00	2021/11/04 17:15:00	0.96

### Turning Movement Data

Leg Direction	Wohlers Ave								E Utica St								Wohlers Ave								E Utica St								Total
	Southbound				Westbound				Northbound				Eastbound				Southbound				Westbound				Northbound				Eastbound				
	Right	Thru	Left	U-Turn	App Total	Peds CV	Peds CCV		Right	Thru	Left	U-Turn	App Total	Peds CV	Peds CCV		Right	Thru	Left	U-Turn	App Total	Peds CV	Peds CCV		Right	Thru	Left	U-Turn	App Total	Peds CV	Peds CCV		
6:30:00 AM	0	2	0	0	2	1	0		0	8	0	0	8	0	0		4	0	0	0	4	0	0		0	3	0	0	3	0	0		17
6:45:00 AM	2	2	0	0	4	0	0		2	9	0	0	12	1	1		1	5	1	0	9	2	1		0	7	2	0	9	0	0		34
Hourly Total	2	4	0	0	6	1	0		2	17	0	0	20	1	1		5	5	1	0	13	2	1		0	10	2	0	12	0	0		51
7:00:00 AM	1	3	3	0	7	0	0		1	19	3	0	23	0	0		2	4	0	0	6	0	0		0	13	0	0	13	0	0		49
7:15:00 AM	1	2	0	0	3	0	0		6	22	1	0	30	1	0		2	3	1	0	7	0	0		1	11	2	0	14	0	1		54
7:30:00 AM	4	0	1	0	5	0	0		3	28	0	0	31	0	0		2	6	2	0	10	0	0		1	19	1	0	21	0	1		67
7:45:00 AM	1	3	0	0	4	0	1		5	32	0	0	38	0	0		7	5	1	0	13	0	1		3	20	1	0	24	0	0		79
Hourly Total	7	8	4	0	19	0	2		15	101	4	0	122	1	0		13	18	4	0	36	0	1		5	63	4	0	72	0	2		249
8:00:00 AM	2	2	3	0	7	0	0		8	32	1	0	41	0	0		3	5	0	0	8	0	0		0	24	1	0	26	0	0		81
8:15:00 AM	1	2	4	0	7	0	1		7	25	3	0	36	0	0		5	6	0	0	11	0	0		1	12	2	0	15	0	0		69
Hourly Total	3	4	7	0	14	0	1		15	57	4	0	77	0	0		8	11	0	0	19	0	0		1	36	3	0	40	0	0		150
4:00:00 PM	1	4	7	0	12	0	1		4	37	3	0	44	0	0		1	17	2	0	20	0	0		1	41	3	0	45	1	1		121
4:15:00 PM	2	9	1	0	12	4	1		4	39	3	0	46	1	0		5	13	3	0	21	0	0		3	38	1	0	42	2	1		121
4:30:00 PM	0	4	1	0	5	6	3		1	29	2	0	32	0	0		6	23	1	0	30	0	1		2	37	3	0	42	0	1		109
4:45:00 PM	0	5	2	0	7	3	2		7	42	3	0	52	0	0		5	10	3	0	18	0	0		1	39	6	0	46	3	0		123
Hourly Total	3	22	11	0	36	13	7		16	147	11	0	174	1	0		17	63	9	0	89	0	1		7	155	13	0	175	6	3		474
5:00:00 PM	4	3	2	0	9	0	0		8	36	3	0	47	0	0		13	7	4	0	24	1	1		3	33	2	0	38	2	0		118
5:15:00 PM	2	3	1	0	6	0	0		6	34	2	0	42	1	0		7	9	1	0	17	2	1		0	32	1	0	33	2	1		98
5:30:00 PM	4	1	5	0	10	0	1		6	35	3	0	44	2	0		3	13	1	0	17	1	1		3	26	1	0	30	0	0		101
5:45:00 PM	1	4	1	0	6	3	2		9	29	1	0	39	0	1		5	9	3	0	17	1	1		0	21	1	0	22	2	0		84
Hourly Total	11	11	9	0	31	3	3		29	134	9	0	172	3	1		28	38	9	0	76	5	4		6	112	5	0	123	6	1		461
Grand Total	28	49	31	0	108	17	14		77	456	28	0	565	6	2		71	135	23	0	232	7	7		19	376	27	0	422	12	6		1328
% Approach	24.5%	46.2%	29.2%	0.0%	0.0%	0.0%	0.0%		13.6%	80.7%	5.0%	0.0%	0.0%	0.0%	0.0%		30.6%	58.2%	9.9%	0.0%	0.0%	0.0%	0.0%		4.5%	89.1%	6.4%	0.0%	0.0%	0.0%	0.0%		0.0%
% Total	2.0%	3.7%	2.3%	0.0%	8.0%	0.0%	0.0%		5.8%	34.4%	2.1%	0.0%	42.6%	0.0%	0.0%		5.4%	10.2%	1.7%	0.0%	17.5%	0.0%	0.0%		1.4%	28.4%	2.0%	0.0%	31.8%	0.0%	0.0%		0.0%
Lights	21	41	21	0	83	0	0		74	430	24	0	528	0	0		71	130	19	0	220	0	0		15	346	22	0	383	0	0		1214
% Lights	80.8%	83.7%	67.7%	0.0%	78.3%	0.0%	0.0%		96.1%	94.3%	85.7%	0.0%	93.5%	0.0%	0.0%		100.0%	96.3%	82.8%	0.0%	94.8%	0.0%	0.0%		78.9%	92.0%	81.5%	0.0%	90.8%	0.0%	0.0%		91.6%
Trucks	0	0	0	0	0	0	0		0	0	0	0	0	0	0		0	0	0	0	0	0	0		0	0	0	0	0	0	0		0
% Trucks	0.0%	0.0%	0.0%	0.0%	0.0%	0.0%	0.0%		0.0%	0.0%	0.0%	0.0%	0.0%	0.0%	0.0%		0.0%	0.0%	0.0%	0.0%	0.0%	0.0%	0.0%		0.0%	0.0%	0.0%	0.0%	0.0%	0.0%	0.0%		0.0%
Buses	5	8	10	0	23	0	0		3	26	4	0	33	0	0		0	5	4	0	9	0	0		3	30	5	0	38	0	0		103
% Buses	19.2%	16.3%	32.3%	0.0%	0.0%	0.0%	0.0%		0.0%	5.7%	14.3%	0.0%	0.0%	0.0%	0.0%		0.0%	3.7%	17.4%	0.0%	0.0%	0.0%	0.0%		15.8%	8.0%	18.5%	0.0%	0.0%	0.0%	0.0%		7.8%
Pedestrians	0	0	0	0	0	17	14		0	0	0	0	0	6	2		0	0	0	0	0	6	6		0	0	0	0	0	12	6		0
% Pedestrians	0.0%	0.0%	0.0%	0.0%	0.0%	100.0%	100.0%		0.0%	0.0%	0.0%	0.0%	0.0%	100.0%	100.0%		0.0%	0.0%	0.0%	0.0%	0.0%	85.7%	85.7%		0.0%	0.0%	0.0%	0.0%	0.0%	100.0%	100.0%		0.0%
Bicycles on Crosswalk	0	0	0	0	0	0	0		0	0	0	0	0	0	0		0	0	0	0	1	1		0	0	0	0	0	0	0		0	
% Bicycles on Crosswalk	0.0%	0.0%	0.0%	0.0%	0.0%	0.0%	0.0%		0.0%	0.0%	0.0%	0.0%	0.0%	0.0%	0.0%		0.0%	0.0%	0.0%	0.0%	14.3%	14.3%		0.0%	0.0%	0.0%	0.0%	0.0%	0.0%	0.0%		0.0%	



Project : VBH Malta NY  
 Site : Site 4  
 Location : 42.948550, -73.790036  
 Survey Date : 2021-04-28, Wednesday

### Turning Movement Data Plot

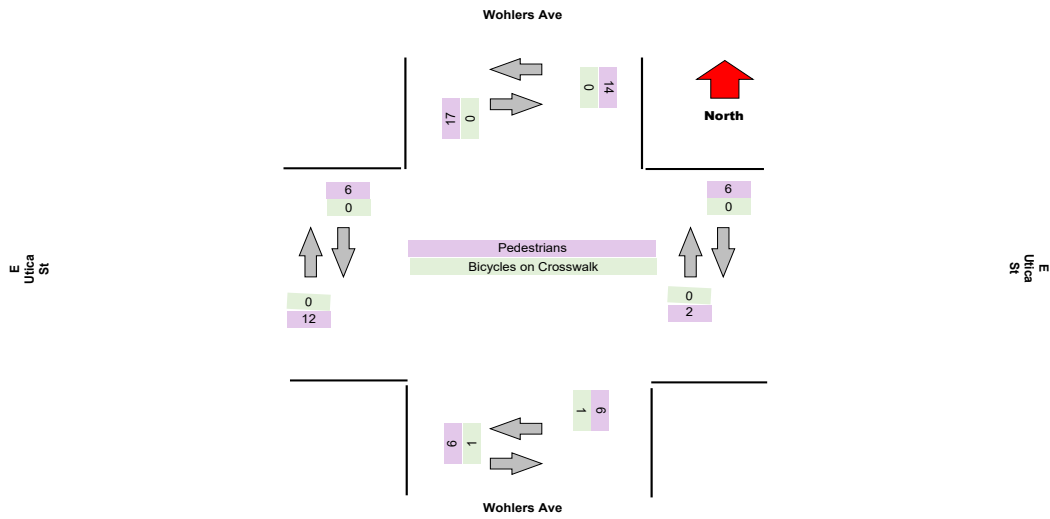
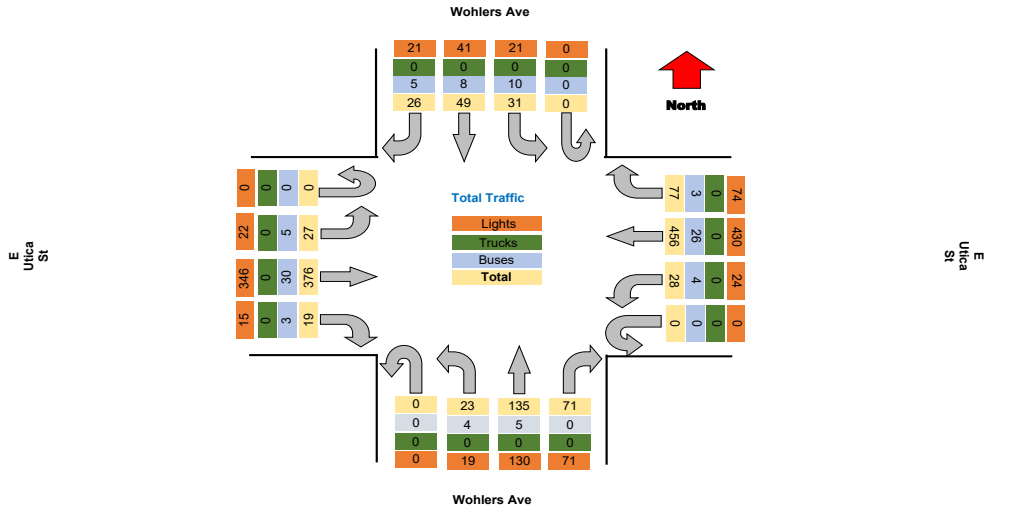

### Turning Movement Peak Hour Data (AM)

7:30:00 AM

Leg Direction	Wohlers Ave								E Ulica St								Wohlers Ave								E Ulica St								Total
	Southbound				Westbound				Northbound				Eastbound				Northbound				Eastbound												
Start Time	Right	Thru	Left	U-Turn	App Total	Peds CW	Peds CCW		Right	Thru	Left	U-Turn	App Total	Peds CW	Peds CCW		Right	Thru	Left	U-Turn	App Total	Peds CW	Peds CCW		Right	Thru	Left	U-Turn	App Total	Peds CW	Peds CCW		
7:30:00 AM	4	0	1	0	5	0	0		3	28	0	0	31	0	0		2	6	2	0	10	0	0		1	19	1	0	21	0	1		67
7:45:00 AM	1	3	0	0	4	0	1		5	32	0	0	38	0	0		7	5	1	0	13	0	1		3	20	1	0	24	0	0		79
8:00:00 AM	2	2	3	0	7	0	0		8	32	1	0	41	0	0		3	5	0	0	8	0	0		0	24	1	0	25	0	0		81
8:15:00 AM	1	2	4	0	7	0	0		7	25	3	0	35	0	0		5	6	0	0	11	0	0		1	12	2	0	15	0	0		69
<b>Grand Total</b>	<b>8</b>	<b>7</b>	<b>8</b>	<b>0</b>	<b>23</b>	<b>0</b>	<b>0</b>		<b>23</b>	<b>117</b>	<b>4</b>	<b>0</b>	<b>146</b>	<b>0</b>	<b>0</b>		<b>17</b>	<b>22</b>	<b>3</b>	<b>0</b>	<b>42</b>	<b>0</b>	<b>1</b>		<b>5</b>	<b>75</b>	<b>5</b>	<b>0</b>	<b>85</b>	<b>0</b>	<b>1</b>		<b>296</b>
% Approach	34.8%	30.4%	34.8%	0.0%	0.0%	0.0%	0.0%		15.6%	80.1%	2.7%	0.0%	0.0%	0.0%	0.0%		40.5%	52.4%	7.1%	0.0%	0.0%	0.0%	0.0%		5.9%	85.2%	5.9%	0.0%	0.0%	0.0%	0.0%		
% Total	2.7%	2.4%	2.7%	0.0%	7.8%	0.0%	0.0%		7.8%	39.5%	1.4%	0.0%	49.3%	0.0%	0.0%		5.7%	7.4%	1.0%	0.0%	14.2%	0.0%	0.0%		1.7%	25.3%	1.7%	0.0%	28.7%	0.0%	0.0%		
PHF	0.500	0.583	0.500	0.000	0.821	0.000	0.000		0.719	0.914	0.333	0.000	0.890	0.000	0.000		0.607	0.917	0.375	0.000	0.808	0.000	0.000		0.417	0.781	0.625	0.000	0.850	0.000	0.000		0.914
Lights	8	6	7	0	21	0	0		22	107	3	0	132	0	0		17	20	2	0	39	0	0		2	64	4	0	70	0	0		262
% Lights	100.0%	85.7%	87.5%	0.0%	91.3%	0.0%	0.0%		95.7%	91.5%	75.0%	0.0%	90.4%	0.0%	0.0%		100.0%	90.9%	66.7%	0.0%	92.9%	0.0%	0.0%		40.0%	85.3%	80.0%	0.0%	82.4%	0.0%	0.0%		88.5%
Trucks	0	0	0	0	0	0	0		0	0	0	0	0	0	0		0	0	0	0	0	0	0		0	0	0	0	0	0	0		0
% Trucks	0.0%	0.0%	0.0%	0.0%	0.0%	0.0%	0.0%		0.0%	0.0%	0.0%	0.0%	0.0%	0.0%	0.0%		0.0%	0.0%	0.0%	0.0%	0.0%	0.0%	0.0%		0.0%	0.0%	0.0%	0.0%	0.0%	0.0%	0.0%		0.0%
Buses	0	1	1	0	2	0	0		1	10	1	0	12	0	0		0	2	1	0	3	0	0		3	11	1	0	15	0	0		32
% Buses	0.0%	14.3%	12.5%	0.0%	0.0%	0.0%	0.0%		4.3%	8.5%	25.0%	0.0%	0.0%	0.0%	0.0%		0.0%	9.1%	33.3%	0.0%	0.0%	0.0%	0.0%		60.0%	14.7%	20.0%	0.0%	0.0%	0.0%	0.0%		10.8%
Pedestrians	0	0	0	0	0	0	2		0	0	0	0	0	0	0		0	0	0	1	0	0	0	1	0	0	0	0	0	0	1	0	1
% Pedestrians	0.0%	0.0%	0.0%	0.0%	0.0%	0.0%	100.0%		0.0%	0.0%	0.0%	0.0%	0.0%	0.0%	0.0%		0.0%	0.0%	0.0%	0.0%	0.0%	0.0%	0.0%	100.0%	0.0%	0.0%	0.0%	0.0%	100.0%	0.0%			
Bicycles on Crosswalk	0	0	0	0	0	0	0		0	0	0	0	0	0	0		0	0	0	0	0	0	0	0	0	0	0	0	0	0	0	0	0
% Bicycles on Crosswalk	0.0%	0.0%	0.0%	0.0%	0.0%	0.0%	0.0%		0.0%	0.0%	0.0%	0.0%	0.0%	0.0%	0.0%		0.0%	0.0%	0.0%	0.0%	0.0%	0.0%	0.0%	0.0%	0.0%	0.0%	0.0%	0.0%	0.0%	0.0%	0.0%		0.0%

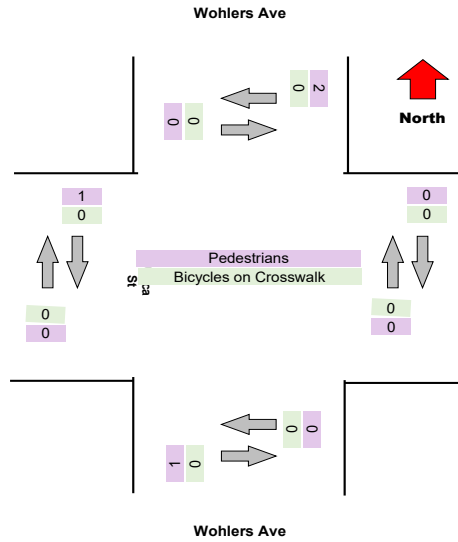
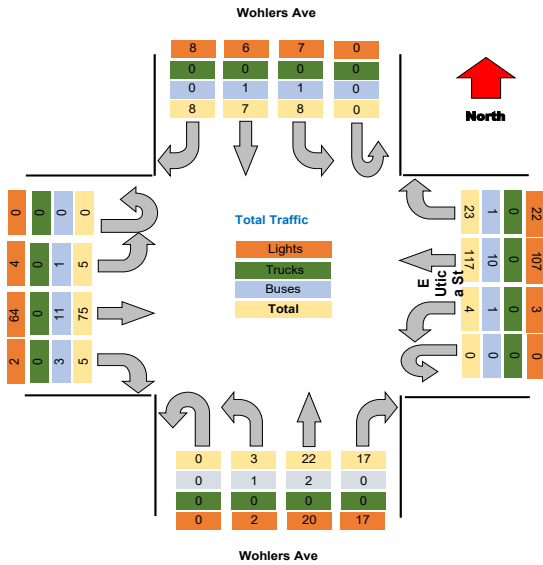

Project : VBH Malta NY  
Site : Site 4  
Location : 42.948550, -73.790036

TSTData.com

Survey Date : 2021-04-28, Wednesday

### Turning Movement Peak Hour Data (PM)

4:15:00 PM

Leg Direction	Wohlers Ave								E Utica St								Wohlers Ave								E Utica St								Total
	Southbound				Westbound				Northbound				Eastbound				Northbound				Eastbound												
	Right	Thru	Left	U-Turn	App Total	Peds CW	Peds CCW		Right	Thru	Left	U-Turn	App Total	Peds CW	Peds CCW		Right	Thru	Left	U-Turn	App Total	Peds CW	Peds CCW		Right	Thru	Left	U-Turn	App Total	Peds CW	Peds CCW		
4:15:00 PM	2	9	1	0	12	4	1	4	39	3	0	0	46	1	0	0	5	13	3	0	21	0	0	0	3	38	1	0	42	2	1	0	121
4:30:00 PM	0	4	1	0	5	6	3	1	29	2	0	0	32	0	0	0	6	23	1	0	30	0	1	0	2	37	3	0	42	0	1	0	109
4:45:00 PM	0	5	2	0	7	3	2	7	42	3	0	0	52	0	0	0	5	10	3	0	18	0	0	0	1	39	6	0	46	3	0	0	123
5:00:00 PM	4	3	2	0	9	0	0	8	35	3	0	0	47	0	0	0	13	7	4	0	24	1	1	0	3	33	2	0	38	2	0	0	118
<b>Grand Total</b>	<b>6</b>	<b>21</b>	<b>6</b>	<b>0</b>	<b>33</b>	<b>13</b>	<b>6</b>	<b>20</b>	<b>146</b>	<b>11</b>	<b>0</b>	<b>0</b>	<b>177</b>	<b>1</b>	<b>0</b>	<b>0</b>	<b>29</b>	<b>53</b>	<b>11</b>	<b>0</b>	<b>93</b>	<b>1</b>	<b>2</b>	<b>0</b>	<b>9</b>	<b>147</b>	<b>12</b>	<b>0</b>	<b>188</b>	<b>7</b>	<b>2</b>	<b>0</b>	<b>471</b>
% Approach	18.2%	63.6%	18.2%	0.0%	0.0%	0.0%	0.0%	11.3%	82.5%	6.2%	0.0%	0.0%	0.0%	0.0%	31.2%	57.0%	11.8%	0.0%	0.0%	0.0%	0.0%	0.0%	0.0%	0.0%	5.4%	87.5%	7.1%	0.0%	0.0%	0.0%	0.0%	0.0%	
% Total	1.3%	4.5%	1.3%	0.0%	7.0%	0.0%	0.0%	4.2%	31.0%	2.3%	0.0%	37.6%	0.0%	0.0%	6.2%	11.3%	2.3%	0.0%	19.7%	0.0%	0.0%	0.0%	0.0%	0.0%	1.9%	31.2%	2.5%	0.0%	35.7%	0.0%	0.0%	0.0%	
PHF	0.375	0.583	0.750	0.000	0.688	0.000	0.000	0.625	0.889	0.917	0.000	0.851	0.000	0.000	0.558	0.576	0.688	0.000	0.775	0.000	0.000	0.000	0.000	0.000	0.750	0.842	0.500	0.000	0.913	0.000	0.000	0.957	
Lights	4	18	4	0	26	0	0	19	141	9	0	169	0	0	29	52	9	0	90	0	0	0	0	0	8	142	12	0	162	0	0	447	
% Lights	66.7%	85.7%	66.7%	0.0%	78.8%	0.0%	0.0%	85.0%	96.6%	81.8%	0.0%	95.5%	0.0%	0.0%	100.0%	98.1%	81.8%	0.0%	96.8%	0.0%	0.0%	0.0%	0.0%	0.0%	88.9%	96.6%	100.0%	0.0%	96.4%	0.0%	0.0%	94.9%	
Trucks	0	0	0	0	0	0	0	0	0	0	0	0	0	0	0	0	0	0	0	0	0	0	0	0	0	0	0	0	0	0	0	0	
% Trucks	0.0%	0.0%	0.0%	0.0%	0.0%	0.0%	0.0%	0.0%	0.0%	0.0%	0.0%	0.0%	0.0%	0.0%	0.0%	0.0%	0.0%	0.0%	0.0%	0.0%	0.0%	0.0%	0.0%	0.0%	0.0%	0.0%	0.0%	0.0%	0.0%	0.0%	0.0%	0.0%	
Buses	2	3	2	0	7	0	0	1	5	2	0	8	0	0	0	1	2	0	3	0	0	0	0	0	0	5	0	0	5	0	0	23	
% Buses	33.3%	14.3%	33.3%	0.0%	0.0%	0.0%	0.0%	5.0%	3.4%	18.2%	0.0%	0.0%	0.0%	0.0%	0.0%	1.9%	18.2%	0.0%	0.0%	0.0%	0.0%	0.0%	0.0%	0.0%	0.0%	3.4%	0.0%	0.0%	0.0%	0.0%	0.0%	4.9%	
Pedestrians	0	0	0	0	0	13	6	0	0	0	0	0	1	0	0	0	0	0	0	1	2	0	0	0	0	0	0	0	0	7	2	0	
% Pedestrians	0.0%	0.0%	0.0%	0.0%	0.0%	100.0%	100.0%	0.0%	0.0%	0.0%	0.0%	0.0%	100.0%	0.0%	0.0%	0.0%	0.0%	0.0%	0.0%	100.0%	100.0%	0.0%	0.0%	0.0%	0.0%	0.0%	0.0%	0.0%	0.0%	100.0%	100.0%	0.0%	
Bicycles on Crosswalk	0	0	0	0	0	0	0	0	0	0	0	0	0	0	0	0	0	0	0	0	0	0	0	0	0	0	0	0	0	0	0	0	
% Bicycles on Crosswalk	0.0%	0.0%	0.0%	0.0%	0.0%	0.0%	0.0%	0.0%	0.0%	0.0%	0.0%	0.0%	0.0%	0.0%	0.0%	0.0%	0.0%	0.0%	0.0%	0.0%	0.0%	0.0%	0.0%	0.0%	0.0%	0.0%	0.0%	0.0%	0.0%	0.0%	0.0%	0.0%	

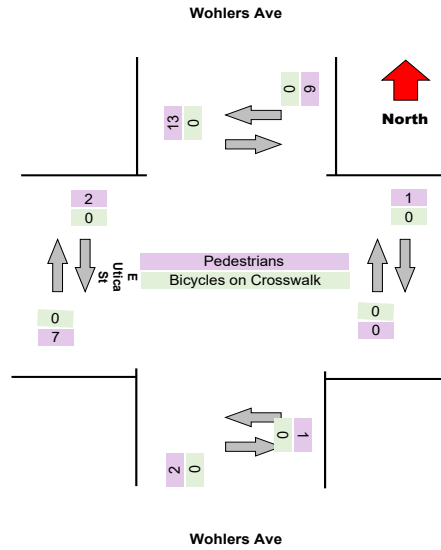
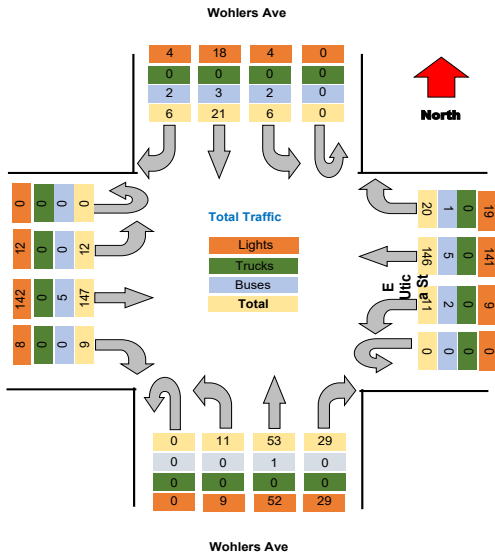

Intersection: Elm St Pine St  
 Location: Kennett Square, PA  
 Site: 01  
 Survey Date: Wednesday, 04-28-2021  
 GPS: 42.948550, -72.790034



TSTData.com

Project	Labella
Project Code	Labella
Site Name	A
Legs and Movements	All Processed Legs & Movement
Bin Size	15 minutes
Survey Date	2021-10-26, Tuesday
Location	A
Latitude and Longitude	42.913814, -78.843710

	Start	End	PHF
Forced Peak AM	2021/10/26 07:30:00	2021/10/26 08:30:00	0.862
Forced Peak PM	2021/10/26 16:30:00	2021/10/26 17:30:00	0.925
AM Peak	2021/10/26 07:30:00	2021/10/26 08:30:00	0.862
PM Peak	2021/10/26 16:15:00	2021/10/26 17:15:00	0.962

Turning Movement Data

Leg Direction	Humboldt Pkwy Southbound						Humboldt Pkwy Northbound						Woodlawn Ave Eastbound						Total
	Right	Thru	U-Turn	App Total	Peds CW	Peds CCW	Thru	Left	U-Turn	App Total	Peds CW	Peds CCW	Right	Left	U-Turn	App Total	Peds CW	Peds CCW	
Start Time																			
6:30:00 AM	2	36	0	38	0	0	0	0	0	0	0	0	0	0	0	0	0	0	3
6:45:00 AM	2	54	0	56	0	0	0	0	0	0	0	0	0	0	0	0	2	0	56
<b>Hourly Total</b>	<b>4</b>	<b>90</b>	<b>0</b>	<b>94</b>	<b>0</b>	<b>0</b>	<b>0</b>	<b>0</b>	<b>0</b>	<b>0</b>	<b>0</b>	<b>0</b>	<b>0</b>	<b>0</b>	<b>0</b>	<b>0</b>	<b>2</b>	<b>3</b>	<b>94</b>
7:00:00 AM	6	45	0	51	0	0	0	0	0	0	0	0	0	0	0	0	1	0	51
7:15:00 AM	6	57	0	63	1	0	0	0	0	0	0	0	0	0	0	0	1	0	63
7:30:00 AM	9	91	0	100	0	0	0	0	0	0	0	0	0	0	0	0	2	2	100
7:45:00 AM	7	83	0	90	0	0	0	0	0	0	0	0	0	0	0	0	3	2	90
<b>Hourly Total</b>	<b>28</b>	<b>276</b>	<b>0</b>	<b>304</b>	<b>1</b>	<b>0</b>	<b>0</b>	<b>0</b>	<b>0</b>	<b>0</b>	<b>0</b>	<b>0</b>	<b>0</b>	<b>0</b>	<b>0</b>	<b>0</b>	<b>7</b>	<b>4</b>	<b>304</b>
8:00:00 AM	3	74	0	77	0	0	0	0	0	0	0	0	0	0	0	0	0	0	77
8:15:00 AM	11	98	0	109	0	0	0	0	0	0	0	0	0	0	0	0	0	1	109
<b>Hourly Total</b>	<b>14</b>	<b>172</b>	<b>0</b>	<b>186</b>	<b>0</b>	<b>0</b>	<b>0</b>	<b>0</b>	<b>0</b>	<b>0</b>	<b>0</b>	<b>0</b>	<b>0</b>	<b>0</b>	<b>0</b>	<b>0</b>	<b>0</b>	<b>1</b>	<b>186</b>
4:00:00 PM	6	160	0	166	0	0	0	0	0	0	0	0	0	0	0	0	0	2	166
4:15:00 PM	7	116	0	123	0	0	0	0	0	0	0	0	0	0	0	0	1	0	123
4:30:00 PM	8	122	0	130	0	2	0	0	0	0	0	0	0	0	0	0	0	3	130
4:45:00 PM	15	112	0	127	0	0	0	0	0	0	0	0	0	0	0	0	0	0	127
<b>Hourly Total</b>	<b>36</b>	<b>510</b>	<b>0</b>	<b>546</b>	<b>0</b>	<b>2</b>	<b>0</b>	<b>0</b>	<b>0</b>	<b>0</b>	<b>0</b>	<b>0</b>	<b>0</b>	<b>0</b>	<b>0</b>	<b>0</b>	<b>1</b>	<b>5</b>	<b>546</b>
5:00:00 PM	15	105	0	120	0	0	0	0	0	0	0	0	0	0	0	0	0	1	120
5:15:00 PM	8	96	0	104	0	0	0	0	0	0	0	0	0	0	0	0	1	3	104
5:30:00 PM	12	88	0	100	0	0	0	0	0	0	0	0	0	0	0	0	0	0	100
5:45:00 PM	10	81	0	91	0	0	0	0	0	0	0	0	0	0	0	0	0	0	91
<b>Hourly Total</b>	<b>45</b>	<b>370</b>	<b>0</b>	<b>415</b>	<b>0</b>	<b>0</b>	<b>0</b>	<b>0</b>	<b>0</b>	<b>0</b>	<b>0</b>	<b>0</b>	<b>0</b>	<b>0</b>	<b>0</b>	<b>0</b>	<b>1</b>	<b>4</b>	<b>415</b>
<b>Grand Total</b>	<b>127</b>	<b>1418</b>	<b>0</b>	<b>1545</b>	<b>1</b>	<b>2</b>	<b>0</b>	<b>0</b>	<b>0</b>	<b>0</b>	<b>0</b>	<b>0</b>	<b>0</b>	<b>0</b>	<b>0</b>	<b>0</b>	<b>11</b>	<b>17</b>	<b>1545</b>
% Approach	8.2%	91.8%	0.0%	0.0%	0.0%	0.0%	0.0%	0.0%	0.0%	0.0%	0.0%	0.0%	0.0%	0.0%	0.0%	0.0%	0.0%	0.0%	0.0%
% Total	8.2%	91.8%	0.0%	100.0%	0.0%	0.0%	0.0%	0.0%	0.0%	0.0%	0.0%	0.0%	0.0%	0.0%	0.0%	0.0%	0.0%	0.0%	0.0%
Lights	118	1365	0	1483	0	0	0	0	0	0	0	0	0	0	0	0	0	0	1483
% Lights	92.9%	96.3%	0.0%	96.0%	0.0%	0.0%	0.0%	0.0%	0.0%	0.0%	0.0%	0.0%	0.0%	0.0%	0.0%	0.0%	0.0%	0.0%	96.0%
Trucks	0	0	0	0	0	0	0	0	0	0	0	0	0	0	0	0	0	0	0
% Trucks	0.0%	0.0%	0.0%	0.0%	0.0%	0.0%	0.0%	0.0%	0.0%	0.0%	0.0%	0.0%	0.0%	0.0%	0.0%	0.0%	0.0%	0.0%	0.0%
Buses	9	53	0	62	0	0	0	0	0	0	0	0	0	0	0	0	0	0	62
% Buses	7.1%	3.7%	0.0%	0.0%	0.0%	0.0%	0.0%	0.0%	0.0%	0.0%	0.0%	0.0%	0.0%	0.0%	0.0%	0.0%	0.0%	0.0%	4.0%
Pedestrians	0	0	0	0	1	2	0	0	0	0	0	0	0	0	0	0	10	17	0
% Pedestrians	0.0%	0.0%	0.0%	0.0%	100.0%	100.0%	0.0%	0.0%	0.0%	0.0%	0.0%	0.0%	0.0%	0.0%	0.0%	0.0%	90.9%	100.0%	0.0%
% Bicycles on Crosswalk	0.0%	0.0%	0.0%	0.0%	0.0%	0.0%	0.0%	0.0%	0.0%	0.0%	0.0%	0.0%	0.0%	0.0%	0.0%	0.0%	9.1%	0.0%	0.0%

Turning Movement Data Plot

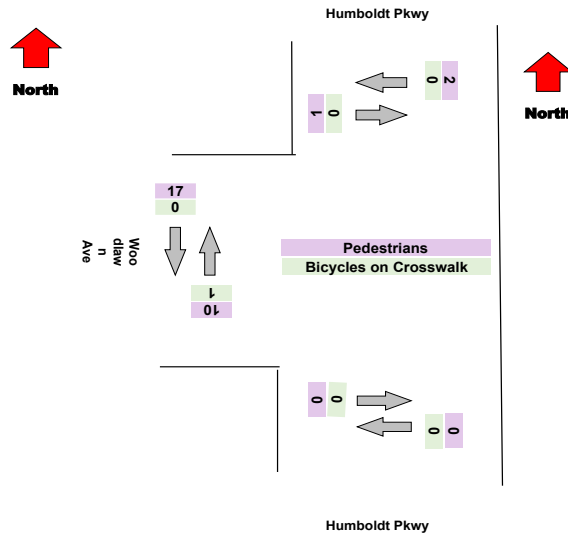
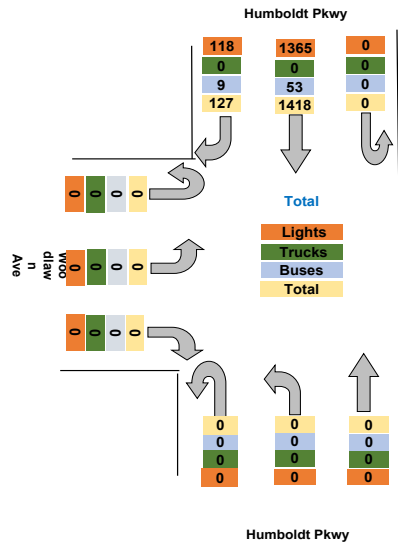

Turning Movement Peak Hour Data (AM)

7:30:00 AM

Leg Direction	Humboldt Pkwy Southbound						Humboldt Pkwy NorthBound						Woodlawn Ave Eastbound						Total	
	Right	Thru	U-Turn	App	Total	Peds CW/Peds CCW	Thru	Left	U-Turn	App	Total	Peds CW/Peds CCW	Right	Left	U-Turn	App	Total	Peds CW/Peds CCW		
7:30:00 AM	9	91	0	100	0	0	0	0	0	0	0	0	0	0	0	0	0	2	2	100
7:45:00 AM	7	83	0	90	0	0	0	0	0	0	0	0	0	0	0	0	3	2	90	
8:00:00 AM	3	74	0	77	0	0	0	0	0	0	0	0	0	0	0	0	0	0	77	
8:15:00 AM	11	98	0	109	0	0	0	0	0	0	0	0	0	0	0	0	0	1	109	
<b>Grand Total</b>	<b>30</b>	<b>346</b>	<b>0</b>	<b>376</b>	<b>0</b>	<b>0</b>	<b>0</b>	<b>0</b>	<b>0</b>	<b>0</b>	<b>0</b>	<b>0</b>	<b>0</b>	<b>0</b>	<b>0</b>	<b>0</b>	<b>5</b>	<b>5</b>	<b>376</b>	
% Approach	8.0%	92.0%	0.0%	0.0%	0.0%	0.0%	14.2%	0.0%	0.0%	0.0%	0.0%	0.0%	45.1%	41.7%	0.0%	0.0%	0.0%	0.0%	0.0%	
% Total	8.0%	92.0%	0.0%	100.0%	0.0%	0.0%	0.0%	0.0%	0.0%	0.0%	0.0%	0.0%	0.0%	0.0%	0.0%	0.0%	0.0%	0.0%	0.0%	
PHF	0.682	0.883	0.000	0.862	0.000	0.000	0.000	0.000	0.000	0.000	0.000	0.000	0.000	0.000	0.000	0.000	0.000	0.000	0.862	
Lights	26	331	0	357	0	0	0	0	0	0	0	0	0	0	0	0	0	0	357	
% Lights	86.7%	95.7%	0.0%	94.9%	0.0%	0.0%	0.0%	0.0%	0.0%	0.0%	0.0%	0.0%	0.0%	0.0%	0.0%	0.0%	0.0%	0.0%	94.9%	
Trucks	0	0	0	0	0	0	0	0	0	0	0	0	0	0	0	0	0	0	0	
% Trucks	0.0%	0.0%	0.0%	0.0%	0.0%	0.0%	0.0%	0.0%	0.0%	0.0%	0.0%	0.0%	0.0%	0.0%	0.0%	0.0%	0.0%	0.0%	0.0%	
Buses	4	15	0	19	0	0	0	0	0	0	0	0	0	0	0	0	0	0	19	
% Buses	13.3%	4.3%	0.0%	0.0%	0.0%	0.0%	0.0%	0.0%	0.0%	0.0%	0.0%	0.0%	0.0%	0.0%	0.0%	0.0%	0.0%	0.0%	5.1%	
Pedestrians	0	0	0	0	0	0	0	0	0	0	0	0	0	0	0	0	4	5	0	
% Pedestrians	0.0%	0.0%	0.0%	0.0%	0.0%	0.0%	0.0%	0.0%	0.0%	0.0%	0.0%	0.0%	0.0%	0.0%	0.0%	0.0%	80.0%	100.0%	0.0%	
Bicycles on Crosswalk	0	0	0	0	0	0	0	0	0	0	0	0	0	0	0	0	1	0	0	
% Bicycles on Crosswalk	0.0%	0.0%	0.0%	0.0%	0.0%	0.0%	0.0%	0.0%	0.0%	0.0%	0.0%	0.0%	0.0%	0.0%	0.0%	0.0%	20.0%	0.0%	0.0%	

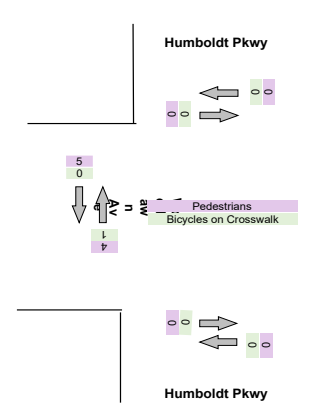
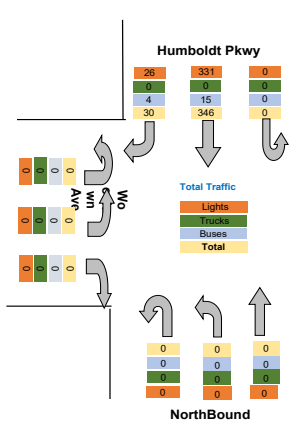

Turning Movement Peak Hour Data (PM)

4:15:00 PM

Leg Direction	Humboldt Pkwy Southbound						Humboldt Pkwy NorthBound						Woodlawn Ave Eastbound						Total
	Right	Thru	U-Turn	App Total	Peds CW	Peds CCW	Thru	Left	U-Turn	App Total	Peds CW	Peds CCW	Right	Left	U-Turn	App Total	Peds CW	Peds CCW	
4:15:00 PM	7	116	0	123	0	0	0	0	0	0	0	0	0	0	0	0	1	0	123
4:30:00 PM	8	122	0	130	0	2	0	0	0	0	0	0	0	0	0	0	0	3	130
4:45:00 PM	15	112	0	127	0	0	0	0	0	0	0	0	0	0	0	0	0	0	127
5:00:00 PM	15	105	0	120	0	0	0	0	0	0	0	0	0	0	0	0	0	1	120
<b>Grand Total</b>	<b>45</b>	<b>455</b>	<b>0</b>	<b>500</b>	<b>0</b>	<b>2</b>	<b>0</b>	<b>0</b>	<b>0</b>	<b>0</b>	<b>0</b>	<b>0</b>	<b>0</b>	<b>0</b>	<b>0</b>	<b>0</b>	<b>1</b>	<b>4</b>	<b>500</b>
% Approach	9.0%	91.0%	0.0%	0.0%	0.0%	0.0%	14.2%	0.0%	0.0%	0.0%	0.0%	0.0%	45.1%	41.7%	0.0%	0.0%	0.0%	0.0%	0.0%
% Total	9.0%	91.0%	0.0%	100.0%	0.0%	0.0%	0.0%	0.0%	0.0%	0.0%	0.0%	0.0%	0.0%	0.0%	0.0%	0.0%	0.0%	0.0%	0.0%
PHF	0.750	0.932	0.000	0.962	0.000	0.000	0.000	0.000	0.000	0.000	0.000	0.000	0.000	0.000	0.000	0.000	0.000	0.000	0.962
Lights	42	434	0	476	0	0	0	0	0	0	0	0	0	0	0	0	0	0	476
% Lights	93.3%	95.4%	0.0%	95.2%	0.0%	0.0%	0.0%	0.0%	0.0%	0.0%	0.0%	0.0%	0.0%	0.0%	0.0%	0.0%	0.0%	0.0%	95.2%
Trucks	0	0	0	0	0	0	0	0	0	0	0	0	0	0	0	0	0	0	0
% Trucks	0.0%	0.0%	0.0%	0.0%	0.0%	0.0%	0.0%	0.0%	0.0%	0.0%	0.0%	0.0%	0.0%	0.0%	0.0%	0.0%	0.0%	0.0%	0.0%
Buses	3	21	0	24	0	0	0	0	0	0	0	0	0	0	0	0	0	0	24
% Buses	6.7%	4.6%	0.0%	0.0%	0.0%	0.0%	0.0%	0.0%	0.0%	0.0%	0.0%	0.0%	0.0%	0.0%	0.0%	0.0%	0.0%	0.0%	4.8%
Pedestrians	0	0	0	0	0	2	0	0	0	0	0	0	0	0	0	0	1	4	0
% Pedestrians	0.0%	0.0%	0.0%	0.0%	0.0%	100.0%	0.0%	0.0%	0.0%	0.0%	0.0%	0.0%	0.0%	0.0%	0.0%	0.0%	100.0%	100.0%	0.0%
Bicycles on Crosswalk	0	0	0	0	0	0	0	0	0	0	0	0	0	0	0	0	0	0	0
% Bicycles on Crosswalk	0.0%	0.0%	0.0%	0.0%	0.0%	0.0%	0.0%	0.0%	0.0%	0.0%	0.0%	0.0%	0.0%	0.0%	0.0%	0.0%	0.0%	0.0%	0.0%

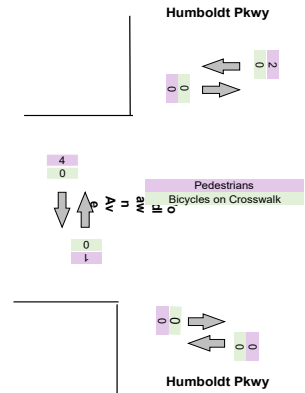
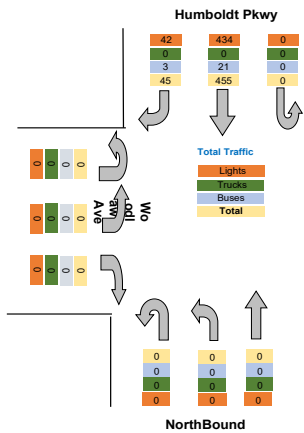

Intersection: Elm St Pine St  
 Location: Kennett Square, PA  
 Site: 01  
 Survey Date: Wednesday, 04-28-2021  
 GPS: 42.948550, -72.790034



TSTData.com

Project	Labella
Project Code	Labella
Site Name	A
Legs and Movements	All Processed Legs & Movement
Bin Size	15 minutes
Survey Date	2021-10-27, Wednesday
Location	A
Latitude and Longitude	42.913814, -78.843710

	Start	End	PHF
Forced Peak AM	2021/10/27 07:30:00	2021/10/27 08:30:00	0.862
Forced Peak PM	2021/10/27 16:30:00	2021/10/27 17:30:00	0.878
AM Peak	2021/10/27 07:30:00	2021/10/27 08:30:00	0.862
PM Peak	2021/10/27 16:15:00	2021/10/27 17:15:00	0.865

Turning Movement Data

Leg Direction	Humboldt Pkwy Southbound						Humboldt Pkwy Northbound						Woodlawn Ave Eastbound						Total
	Right	Thru	U-Turn	App Total	Peds CW	Peds CCW	Thru	Left	U-Turn	App Total	Peds CW	Peds CCW	Right	Left	U-Turn	App Total	Peds CW	Peds CCW	
Start Time																			
6:30:00 AM	1	40	0	41	0	0	0	0	0	0	0	0	0	0	0	0	0	0	3
6:45:00 AM	2	49	0	51	0	0	0	0	0	0	0	0	0	0	0	0	1	0	51
Hourly Total	3	89	0	92	0	0	0	0	0	0	0	0	0	0	0	1	3	0	92
7:00:00 AM	5	38	0	43	0	0	0	0	0	0	0	0	0	0	0	0	1	0	43
7:15:00 AM	7	60	0	67	0	0	0	0	0	0	0	0	0	0	0	0	1	0	67
7:30:00 AM	9	74	0	83	0	0	0	0	0	0	0	0	0	0	0	0	0	0	83
7:45:00 AM	10	108	0	118	0	0	0	0	0	0	0	0	0	0	0	2	1	0	118
Hourly Total	31	280	0	311	0	0	0	0	0	0	0	0	0	0	0	4	1	0	311
8:00:00 AM	6	95	0	101	0	0	0	0	0	0	0	0	0	0	0	0	0	1	101
8:15:00 AM	9	96	0	105	0	0	0	0	0	0	0	0	0	0	0	1	0	0	105
Hourly Total	15	191	0	206	0	0	0	0	0	0	0	0	0	0	0	1	1	0	206
4:00:00 PM	10	113	0	123	0	0	0	0	0	0	0	0	0	0	0	1	0	0	123
4:15:00 PM	15	103	0	118	0	0	0	0	0	0	0	0	0	0	0	0	0	0	118
4:30:00 PM	13	120	0	133	0	0	0	0	0	0	0	0	0	0	0	1	0	0	133
4:45:00 PM	11	92	0	103	0	0	0	0	0	0	0	0	0	0	0	0	2	0	103
Hourly Total	49	428	0	477	0	0	0	0	0	0	0	0	0	0	0	2	2	0	477
5:00:00 PM	6	100	0	106	0	0	0	0	0	0	0	0	0	0	0	0	1	1	106
5:15:00 PM	13	112	0	125	0	0	0	0	0	0	0	0	0	0	0	1	1	0	125
5:30:00 PM	11	93	0	104	0	0	0	0	0	0	0	0	0	0	0	0	1	1	104
5:45:00 PM	11	86	0	97	0	0	0	0	0	0	0	0	0	0	0	0	0	0	97
Hourly Total	41	391	0	432	0	0	0	0	0	0	0	0	0	0	0	2	3	0	432
Grand Total	139	1379	0	1518	0	0	0	0	0	0	0	0	0	0	0	10	10	0	1518
% Approach	9.2%	90.8%	0.0%	0.0%	0.0%	0.0%	0.0%	0.0%	0.0%	0.0%	0.0%	0.0%	0.0%	0.0%	0.0%	0.0%	0.0%	0.0%	0.0%
% Total	9.2%	90.8%	0.0%	100.0%	0.0%	0.0%	0.0%	0.0%	0.0%	0.0%	0.0%	0.0%	0.0%	0.0%	0.0%	0.0%	0.0%	0.0%	0.0%
Lights	125	1326	0	1451	0	0	0	0	0	0	0	0	0	0	0	0	0	0	1451
% Lights	89.9%	96.2%	0.0%	95.6%	0.0%	0.0%	0.0%	0.0%	0.0%	0.0%	0.0%	0.0%	0.0%	0.0%	0.0%	0.0%	0.0%	0.0%	95.6%
Trucks	0	0	0	0	0	0	0	0	0	0	0	0	0	0	0	0	0	0	0
% Trucks	0.0%	0.0%	0.0%	0.0%	0.0%	0.0%	0.0%	0.0%	0.0%	0.0%	0.0%	0.0%	0.0%	0.0%	0.0%	0.0%	0.0%	0.0%	0.0%
Buses	13	52	0	65	0	0	0	0	0	0	0	0	0	0	0	0	0	0	65
% Buses	9.4%	3.8%	0.0%	0.0%	0.0%	0.0%	0.0%	0.0%	0.0%	0.0%	0.0%	0.0%	0.0%	0.0%	0.0%	0.0%	0.0%	0.0%	4.3%
Pedestrians	0	0	0	0	0	0	0	0	0	0	0	0	0	0	0	9	10	0	0
% Pedestrians	0.0%	0.0%	0.0%	0.0%	0.0%	0.0%	0.0%	0.0%	0.0%	0.0%	0.0%	0.0%	0.0%	0.0%	0.0%	90.0%	100.0%	0.0%	0.0%
% Bicycles on Crosswalk	0.0%	0.0%	0.0%	0.0%	0.0%	0.0%	0.0%	0.0%	0.0%	0.0%	0.0%	0.0%	0.0%	0.0%	0.0%	10.0%	0.0%	0.0%	0.0%





Turning Movement Peak Hour Data (AM)

7:30:00 AM

Leg Direction	Humboldt Pkwy Southbound						Humboldt Pkwy NorthBound						Woodlawn Ave Eastbound						Total	
	Right	Thru	U-Turn	App Total	Peds CW	Peds CCW	Thru	Left	U-Turn	App Total	Peds CW	Peds CCW	Right	Left	U-Turn	App Total	Peds CW	Peds CCW		
7:30:00 AM	9	74	0	83	0	0	0	0	0	0	0	0	0	0	0	0	0	0	0	83
7:45:00 AM	10	108	0	118	0	0	0	0	0	0	0	0	0	0	0	0	2	0	1	118
8:00:00 AM	6	95	0	101	0	0	0	0	0	0	0	0	0	0	0	0	0	1	0	101
8:15:00 AM	9	96	0	105	0	0	0	0	0	0	0	0	0	0	0	1	0	0	0	105
<b>Grand Total</b>	<b>34</b>	<b>373</b>	<b>0</b>	<b>407</b>	<b>0</b>	<b>0</b>	<b>0</b>	<b>0</b>	<b>0</b>	<b>0</b>	<b>0</b>	<b>0</b>	<b>0</b>	<b>0</b>	<b>0</b>	<b>3</b>	<b>2</b>	<b>0</b>	<b>0</b>	<b>407</b>
% Approach	8.4%	91.6%	0.0%	0.0%	0.0%	0.0%	14.2%	0.0%	0.0%	0.0%	0.0%	0.0%	45.1%	41.7%	0.0%	0.0%	0.0%	0.0%	0.0%	0.0%
% Total	8.4%	91.6%	0.0%	100.0%	0.0%	0.0%	0.0%	0.0%	0.0%	0.0%	0.0%	0.0%	0.0%	0.0%	0.0%	0.0%	0.0%	0.0%	0.0%	0.0%
PHF	0.850	0.863	0.000	0.862	0.000	0.000	0.000	0.000	0.000	0.000	0.000	0.000	0.000	0.000	0.000	0.000	0.000	0.000	0.000	0.862
Lights	30	353	0	383	0	0	0	0	0	0	0	0	0	0	0	0	0	0	0	383
% Lights	88.2%	94.6%	0.0%	94.1%	0.0%	0.0%	0.0%	0.0%	0.0%	0.0%	0.0%	0.0%	0.0%	0.0%	0.0%	0.0%	0.0%	0.0%	0.0%	94.1%
Trucks	0	0	0	0	0	0	0	0	0	0	0	0	0	0	0	0	0	0	0	0
% Trucks	0.0%	0.0%	0.0%	0.0%	0.0%	0.0%	0.0%	0.0%	0.0%	0.0%	0.0%	0.0%	0.0%	0.0%	0.0%	0.0%	0.0%	0.0%	0.0%	0.0%
Buses	4	20	0	24	0	0	0	0	0	0	0	0	0	0	0	0	0	0	0	24
% Buses	11.8%	5.4%	0.0%	0.0%	0.0%	0.0%	0.0%	0.0%	0.0%	0.0%	0.0%	0.0%	0.0%	0.0%	0.0%	0.0%	0.0%	0.0%	0.0%	5.9%
Pedestrians	0	0	0	0	0	0	0	0	0	0	0	0	0	0	0	0	3	2	0	0
% Pedestrians	0.0%	0.0%	0.0%	0.0%	0.0%	0.0%	0.0%	0.0%	0.0%	0.0%	0.0%	0.0%	0.0%	0.0%	0.0%	0.0%	100.0%	100.0%	0.0%	0.0%
Bicycles on Crosswalk	0	0	0	0	0	0	0	0	0	0	0	0	0	0	0	0	0	0	0	0
% Bicycles on Crosswalk	0.0%	0.0%	0.0%	0.0%	0.0%	0.0%	0.0%	0.0%	0.0%	0.0%	0.0%	0.0%	0.0%	0.0%	0.0%	0.0%	0.0%	0.0%	0.0%	0.0%

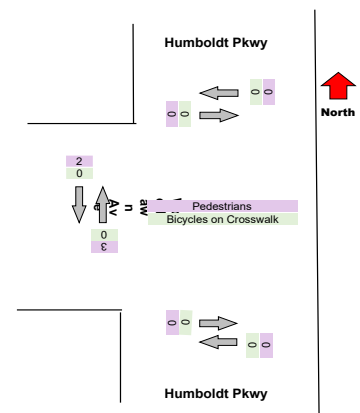
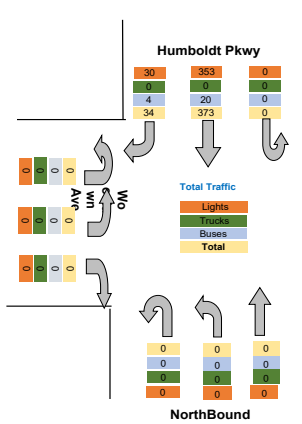

Turning Movement Peak Hour Data (PM)

4:15:00 PM

Leg Direction	Humboldt Pkwy Southbound						Humboldt Pkwy NorthBound						Woodlawn Ave Eastbound						Total
	Right	Thru	U-Turn	App Total	Peds CW	Peds CCW	Thru	Left	U-Turn	App Total	Peds CW	Peds CCW	Right	Left	U-Turn	App Total	Peds CW	Peds CCW	
4:15:00 PM	15	103	0	118	0	0	0	0	0	0	0	0	0	0	0	0	0	0	118
4:30:00 PM	13	120	0	133	0	0	0	0	0	0	0	0	0	0	0	0	1	0	133
4:45:00 PM	11	92	0	103	0	0	0	0	0	0	0	0	0	0	0	0	0	2	103
5:00:00 PM	6	100	0	106	0	0	0	0	0	0	0	0	0	0	0	0	1	1	106
<b>Grand Total</b>	<b>45</b>	<b>415</b>	<b>0</b>	<b>460</b>	<b>0</b>	<b>0</b>	<b>0</b>	<b>0</b>	<b>0</b>	<b>0</b>	<b>0</b>	<b>0</b>	<b>0</b>	<b>0</b>	<b>0</b>	<b>0</b>	<b>2</b>	<b>3</b>	<b>460</b>
% Approach	9.8%	90.2%	0.0%	0.0%	0.0%	0.0%	14.2%	0.0%	0.0%	0.0%	0.0%	0.0%	45.1%	41.7%	0.0%	0.0%	0.0%	0.0%	0.0%
% Total	9.8%	90.2%	0.0%	100.0%	0.0%	0.0%	0.0%	0.0%	0.0%	0.0%	0.0%	0.0%	0.0%	0.0%	0.0%	0.0%	0.0%	0.0%	0.0%
PHF	0.750	0.865	0.000	0.865	0.000	0.000	0.000	0.000	0.000	0.000	0.000	0.000	0.000	0.000	0.000	0.000	0.000	0.000	0.865
Lights	43	399	0	442	0	0	0	0	0	0	0	0	0	0	0	0	0	0	442
% Lights	95.6%	96.1%	0.0%	96.1%	0.0%	0.0%	0.0%	0.0%	0.0%	0.0%	0.0%	0.0%	0.0%	0.0%	0.0%	0.0%	0.0%	0.0%	96.1%
Trucks	0	0	0	0	0	0	0	0	0	0	0	0	0	0	0	0	0	0	0
% Trucks	0.0%	0.0%	0.0%	0.0%	0.0%	0.0%	0.0%	0.0%	0.0%	0.0%	0.0%	0.0%	0.0%	0.0%	0.0%	0.0%	0.0%	0.0%	0.0%
Buses	2	15	0	17	0	0	0	0	0	0	0	0	0	0	0	0	0	0	17
% Buses	4.4%	3.6%	0.0%	0.0%	0.0%	0.0%	0.0%	0.0%	0.0%	0.0%	0.0%	0.0%	0.0%	0.0%	0.0%	0.0%	0.0%	0.0%	3.7%
Pedestrians	0	0	0	0	0	0	0	0	0	0	0	0	0	0	0	0	2	3	0
% Pedestrians	0.0%	0.0%	0.0%	0.0%	0.0%	0.0%	0.0%	0.0%	0.0%	0.0%	0.0%	0.0%	0.0%	0.0%	0.0%	0.0%	100.0%	100.0%	0.0%
Bicycles on Crosswalk	0	0	0	0	0	0	0	0	0	0	0	0	0	0	0	0	0	0	0
% Bicycles on Crosswalk	0.0%	0.0%	0.0%	0.0%	0.0%	0.0%	0.0%	0.0%	0.0%	0.0%	0.0%	0.0%	0.0%	0.0%	0.0%	0.0%	0.0%	0.0%	0.0%

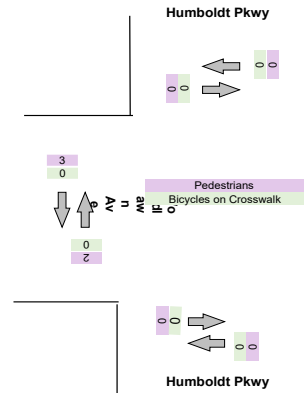
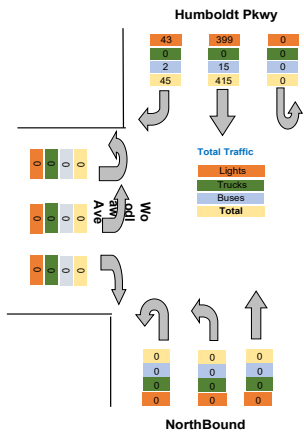



Turning Movement Data Plot

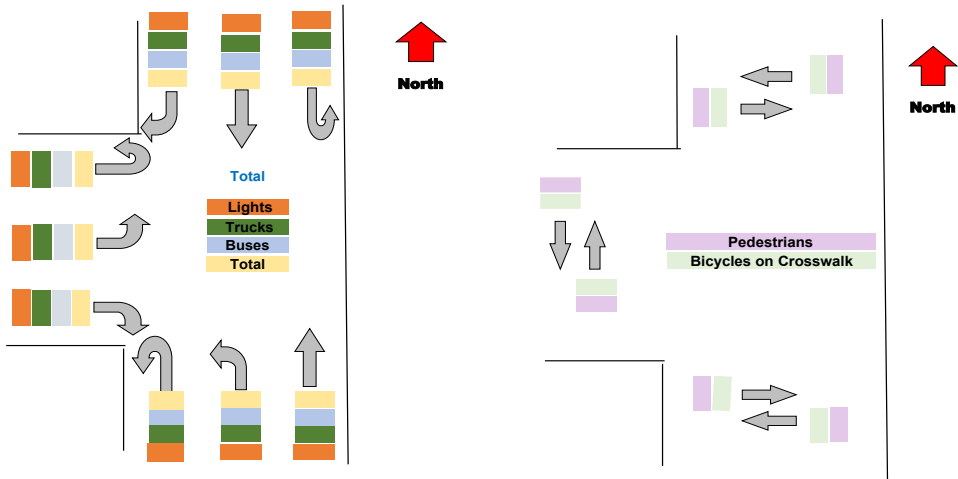

Turning Movement Peak Hour Data (AM)

7:30:00 AM

Leg Direction	Humboldt Pkwy Southbound						Humboldt Pkwy Northbound						Woodlawn Ave Eastbound						Total
	Right	Thru	U-Turn	App Total	Peds CW	Peds CCW	Thru	Left	U-Turn	App Total	Peds CW	Peds CCW	Right	Left	U-Turn	App Total	Peds CW	Peds CCW	
7:30:00 AM	8	85	0	93	0	0	0	0	0	0	0	0	0	0	0	0	0	2	1
7:45:00 AM	7	126	0	133	0	0	0	0	0	0	0	0	0	0	0	0	2	2	
8:00:00 AM	7	99	0	106	0	0	0	0	0	0	0	1	0	0	1	1	1	1	
8:15:00 AM	11	97	0	108	0	0	0	0	0	0	0	0	0	0	0	0	0	0	
<b>Grand Total</b>	33	407	0	440	0	0	0	0	0	0	0	1	0	0	1	5	4		
% Approach	7.5%	92.5%	0.0%	0.0%	0.0%	0.0%	14.2%	0.0%	0.0%	0.0%	0.0%	45.1%	41.7%	0.0%	0.0%	0.0%	0.0%	0.0%	
% Total	7.5%	92.3%	0.0%	99.8%	0.0%	0.0%	0.0%	0.0%	0.0%	0.0%	0.0%	0.2%	0.0%	0.0%	0.2%	0.0%	0.0%	0.0%	
PHF	0.750	0.808	0.000	0.827	0.000	0.000	0.000	0.000	0.000	0.000	0.000	0.250	0.000	0.000	0.250	0.000	0.000	0.000	
Lights	28	391	0	419	0	0	0	0	0	0	0	1	0	0	1	0	0	0	
% Lights	84.8%	96.1%	0.0%	95.2%	0.0%	0.0%	0.0%	0.0%	0.0%	0.0%	0.0%	#####	0.0%	0.0%	100.0%	0.0%	0.0%	0.0%	
Trucks	0	1	0	1	0	0	0	0	0	0	0	0	0	0	0	0	0	0	
% Trucks	0.0%	0.2%	0.0%	0.2%	0.0%	0.0%	0.0%	0.0%	0.0%	0.0%	0.0%	0.0%	0.0%	0.0%	0.0%	0.0%	0.0%	0.0%	
Buses	5	15	0	20	0	0	0	0	0	0	0	0	0	0	0	0	0	0	
% Buses	15.2%	3.7%	0.0%	0.0%	0.0%	0.0%	0.0%	0.0%	0.0%	0.0%	0.0%	0.0%	0.0%	0.0%	0.0%	0.0%	0.0%	0.0%	
Pedestrians	0	0	0	0	0	0	0	0	0	0	0	0	0	0	0	5	4	0	
% Pedestrians	0.0%	0.0%	0.0%	0.0%	0.0%	0.0%	0.0%	0.0%	0.0%	0.0%	0.0%	0.0%	0.0%	0.0%	0.0%	100.0%	100.0%	0.0%	
Bicycles on Crosswalk	0	0	0	0	0	0	0	0	0	0	0	0	0	0	0	0	0	0	
% Bicycles on Crosswalk	0.0%	0.0%	0.0%	0.0%	0.0%	0.0%	0.0%	0.0%	0.0%	0.0%	0.0%	0.0%	0.0%	0.0%	0.0%	0.0%	0.0%	0.0%	

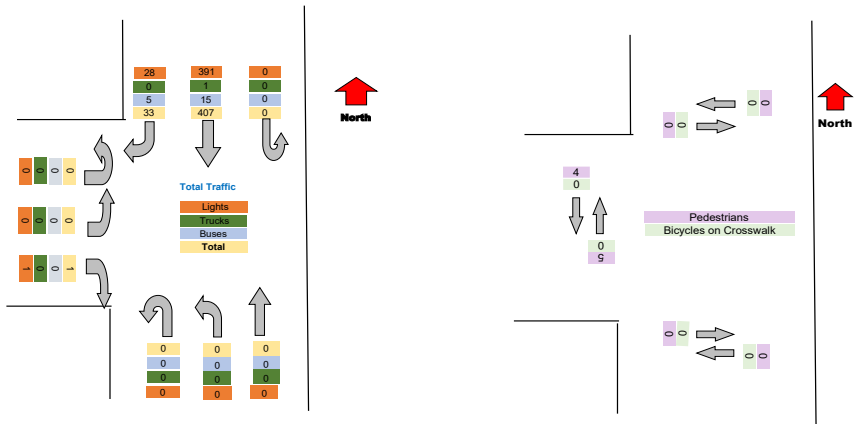

Turning Movement Peak Hour Data (PM)

4:15:00 PM

Leg Direction	Humboldt Pkwy Southbound						Humboldt Pkwy Northbound						Woodlawn Ave Eastbound						Total
	Right	Thru	U-Turn	App Total	Peds CW	Peds CCW	Thru	Left	U-Turn	App Total	Peds CW	Peds CCW	Right	Left	U-Turn	App Total	Peds CW	Peds CCW	
4:15:00 PM	13	136	0	149	0	0	0	0	0	0	0	0	0	0	0	0	0	1	149
4:30:00 PM	4	119	0	123	0	0	0	0	0	0	0	0	0	0	0	0	0	0	123
4:45:00 PM	14	118	0	132	0	0	0	0	0	0	0	0	0	0	0	1	0	0	132
5:00:00 PM	15	105	0	120	0	0	0	0	0	0	0	0	0	0	0	0	0	0	120
<b>Grand Total</b>	46	478	0	524	0	0	0	0	0	0	0	0	0	0	0	1	3	0	524
% Approach	8.8%	91.2%	0.0%	0.0%	0.0%	0.0%	14.2%	0.0%	0.0%	0.0%	0.0%	0.0%	45.1%	41.7%	0.0%	0.0%	0.0%	0.0%	0.0%
% Total	8.8%	91.2%	0.0%	100.0%	0.0%	0.0%	0.0%	0.0%	0.0%	0.0%	0.0%	0.0%	0.0%	0.0%	0.0%	0.0%	0.0%	0.0%	0.0%
PHF	0.767	0.879	0.000	0.879	0.000	0.000	0.000	0.000	0.000	0.000	0.000	0.000	0.000	0.000	0.000	0.000	0.000	0.000	0.879
Lights	43	460	0	503	0	0	0	0	0	0	0	0	0	0	0	0	0	0	503
% Lights	93.5%	96.2%	0.0%	96.0%	0.0%	0.0%	0.0%	0.0%	0.0%	0.0%	0.0%	0.0%	0.0%	0.0%	0.0%	0.0%	0.0%	0.0%	96.0%
Trucks	0	0	0	0	0	0	0	0	0	0	0	0	0	0	0	0	0	0	0
% Trucks	0.0%	0.0%	0.0%	0.0%	0.0%	0.0%	0.0%	0.0%	0.0%	0.0%	0.0%	0.0%	0.0%	0.0%	0.0%	0.0%	0.0%	0.0%	0.0%
Buses	3	17	0	20	0	0	0	0	0	0	0	0	0	0	0	0	0	0	20
% Buses	6.5%	3.6%	0.0%	0.0%	0.0%	0.0%	0.0%	0.0%	0.0%	0.0%	0.0%	0.0%	0.0%	0.0%	0.0%	0.0%	0.0%	0.0%	3.8%
Pedestrians	0	0	0	0	0	0	0	0	0	0	0	0	0	0	0	1	3	0	0
% Pedestrians	0.0%	0.0%	0.0%	0.0%	0.0%	0.0%	0.0%	0.0%	0.0%	0.0%	0.0%	0.0%	0.0%	0.0%	0.0%	0.0%	100.0%	100.0%	0.0%
Bicycles on Crosswalk	0	0	0	0	0	0	0	0	0	0	0	0	0	0	0	0	0	0	0
% Bicycles on Crosswalk	0.0%	0.0%	0.0%	0.0%	0.0%	0.0%	0.0%	0.0%	0.0%	0.0%	0.0%	0.0%	0.0%	0.0%	0.0%	0.0%	0.0%	0.0%	0.0%

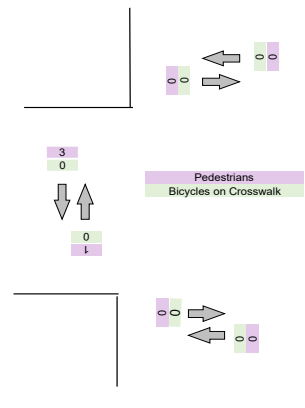
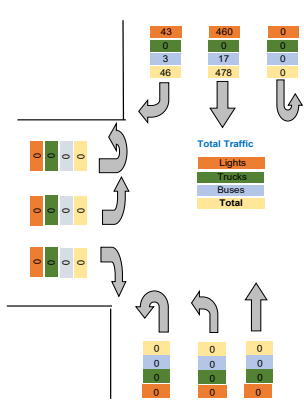

Project	Labella
Project Code	Labella
Site Name	B
Legs and Movements	All Processed Legs & Movements
Bin Size	15 minutes
Survey Date	2021-10-26, Tuesday
Location	B
Latitude and Longitude	42.912267, -78.843718

	Start	End	PHF
Forced Peak AM	2021/10/26 07:30:00	2021/10/26 08:30:00	0.862
Forced Peak PM	2021/10/26 16:30:00	2021/10/26 17:30:00	0.916
AM Peak	2021/10/26 07:30:00	2021/10/26 08:30:00	0.862
PM Peak	2021/10/26 16:15:00	2021/10/26 17:15:00	0.942

Turning Movement Data

Leg Direction	Humboldt Pkwy Southbound						Humboldt Pkwy NorthBound						Glenwood Ave Eastbound					
	Right	Thru	U-Turn	App Total	Peds	CCW	Thru	Left	U-Turn	App Total	Peds	CCW	Right	Left	U-Turn	App Total	Peds	CCW
Start Time																		
6:30:00 AM	0	34	0	34	0	0	0	0	0	0	0	0	6	0	0	6	1	0
6:45:00 AM	0	61	0	61	0	0	0	0	0	0	0	0	1	0	0	1	0	1
<b>Hourly Total</b>	0	95	0	95	0	0	0	0	0	0	0	0	7	0	0	7	1	1
7:00:00 AM	0	43	0	43	0	0	0	0	0	0	0	0	4	0	0	4	1	0
7:15:00 AM	0	57	0	57	0	0	0	0	0	0	0	0	2	0	0	2	0	1
7:30:00 AM	0	91	0	91	0	0	0	0	0	0	0	0	15	0	0	15	1	1
7:45:00 AM	0	89	0	89	0	0	0	0	0	0	0	0	10	0	0	10	1	2
<b>Hourly Total</b>	0	280	0	280	0	0	0	0	0	0	0	0	31	0	0	31	3	4
8:00:00 AM	0	78	0	78	0	0	0	0	0	0	0	0	1	0	0	1	0	0
8:15:00 AM	0	108	0	108	0	0	0	0	0	0	0	0	8	0	0	8	0	1
<b>Hourly Total</b>	0	186	0	186	0	0	0	0	0	0	0	0	9	0	0	9	0	1
4:00:00 PM	0	163	0	163	0	0	0	0	0	0	0	0	7	0	0	7	0	0
4:15:00 PM	0	108	0	108	0	0	0	0	0	0	0	0	5	0	0	5	0	0
4:30:00 PM	0	119	0	119	0	0	0	0	0	0	0	0	6	0	0	6	0	3
4:45:00 PM	0	112	0	112	0	0	0	0	0	0	0	0	4	0	0	4	0	0
<b>Hourly Total</b>	0	502	0	502	0	0	0	0	0	0	0	0	22	0	0	22	0	3
5:00:00 PM	0	109	0	109	0	0	0	0	0	0	0	0	8	0	0	8	0	1
5:15:00 PM	0	95	0	95	0	0	0	0	0	0	0	0	5	0	0	5	1	2
5:30:00 PM	0	91	0	91	0	0	0	0	0	0	0	0	4	0	0	4	0	0
5:45:00 PM	0	76	0	76	0	0	0	0	0	0	0	0	8	0	0	8	0	0
<b>Hourly Total</b>	0	371	0	371	0	0	0	0	0	0	0	0	25	0	0	25	1	3
<b>Grand Total</b>	0	1434	0	1434	0	0	0	0	0	0	0	0	94	0	0	94	5	12
% Approach	0.0%	100.0%	0.0%	0.0%	0.0%	0.0%	0.0%	0.0%	0.0%	0.0%	0.0%	0.0%	100.0%	0.0%	0.0%	0.0%	0.0%	0.0%
% Total	0.0%	93.8%	0.0%	93.8%	0.0%	0.0%	0.0%	0.0%	0.0%	0.0%	0.0%	0.0%	6.2%	0.0%	0.0%	6.2%	0.0%	0.0%
Lights	0	1382	0	1382	0	0	0	0	0	0	0	0	87	0	0	87	0	0
% Lights	0.0%	96.4%	0.0%	96.4%	0.0%	0.0%	0.0%	0.0%	0.0%	0.0%	0.0%	0.0%	92.6%	0.0%	0.0%	92.6%	0.0%	0.0%
Trucks	0	0	0	0	0	0	0	0	0	0	0	0	0	0	0	0	0	0
% Trucks	0.0%	0.0%	0.0%	0.0%	0.0%	0.0%	0.0%	0.0%	0.0%	0.0%	0.0%	0.0%	0.0%	0.0%	0.0%	0.0%	0.0%	0.0%
Buses	0	52	0	52	0	0	0	0	0	0	0	0	7	0	0	7	0	0
% Buses	0.0%	3.6%	0.0%	3.6%	0.0%	0.0%	0.0%	0.0%	0.0%	0.0%	0.0%	0.0%	7.4%	0.0%	0.0%	7.4%	0.0%	0.0%
Pedestrians	0	0	0	0	0	0	0	0	0	0	0	0	0	0	0	0	4	12
% Pedestrians	0.0%	0.0%	0.0%	0.0%	0.0%	0.0%	0.0%	0.0%	0.0%	0.0%	0.0%	0.0%	0.0%	0.0%	0.0%	0.0%	80.0%	100.0%
% Bicycles on Crosswalk	0.0%	0.0%	0.0%	0.0%	0.0%	0.0%	0.0%	0.0%	0.0%	0.0%	0.0%	0.0%	0.0%	0.0%	0.0%	0.0%	20.0%	0.0%



Turning Movement Data Plot

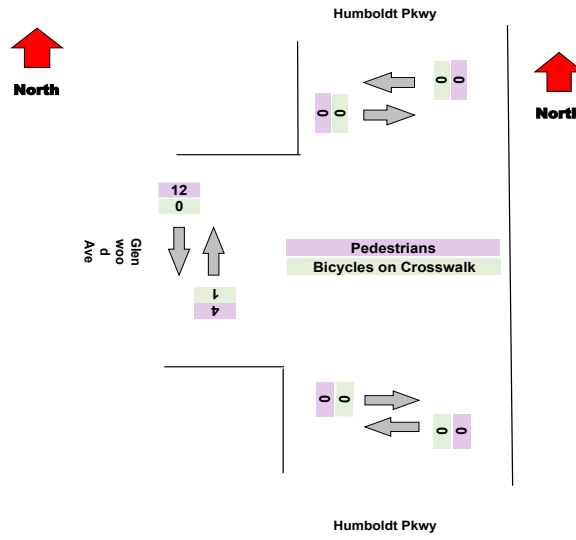
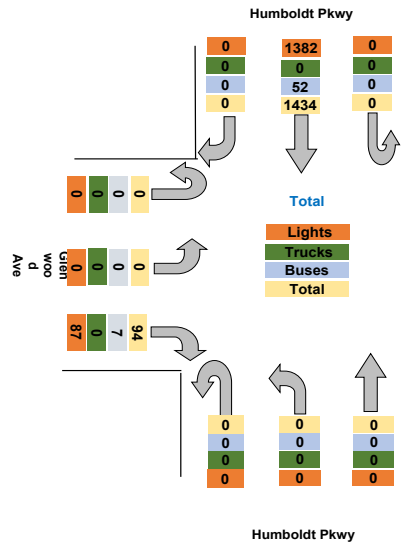

Turning Movement Peak Hour Data (AM)

7:30:00 AM

Leg Direction	Humboldt Pkwy Southbound						Humboldt Pkwy NorthBound						Glenwood Ave Eastbound					
	Right	Thru	U-Turn	App Total	Peds CW	Peds CCW	Thru	Left	U-Turn	App Total	Peds CW	Peds CCW	Right	Left	U-Turn	App Total	Peds CW	Peds CCW
7:30:00 AM	0	91	0	91	0	0	0	0	0	0	0	0	15	0	0	15	1	1
7:45:00 AM	0	89	0	89	0	0	0	0	0	0	0	0	10	0	0	10	1	2
8:00:00 AM	0	78	0	78	0	0	0	0	0	0	0	0	1	0	0	1	0	0
8:15:00 AM	0	108	0	108	0	0	0	0	0	0	0	0	8	0	0	8	0	1
<b>Grand Total</b>	0	366	0	366	0	0	0	0	0	0	0	0	34	0	0	34	2	4
% Approach	0.0%	100.0%	0.0%	0.0%	0.0%	0.0%	14.2%	0.0%	0.0%	0.0%	0.0%	0.0%	45.1%	41.7%	0.0%	0.0%	0.0%	0.0%
% Total	0.0%	91.5%	0.0%	91.5%	0.0%	0.0%	0.0%	0.0%	0.0%	0.0%	0.0%	0.0%	8.5%	0.0%	0.0%	8.5%	0.0%	0.0%
PHF	0.000	0.847	0.000	0.847	0.000	0.000	0.000	0.000	0.000	0.000	0.000	0.000	0.567	0.000	0.000	0.567	0.000	0.000
Lights	0	350	0	350	0	0	0	0	0	0	0	0	31	0	0	31	0	0
% Lights	0.0%	95.6%	0.0%	95.6%	0.0%	0.0%	0.0%	0.0%	0.0%	0.0%	0.0%	0.0%	91.2%	0.0%	0.0%	91.2%	0.0%	0.0%
Trucks	0	0	0	0	0	0	0	0	0	0	0	0	0	0	0	0	0	0
% Trucks	0.0%	0.0%	0.0%	0.0%	0.0%	0.0%	0.0%	0.0%	0.0%	0.0%	0.0%	0.0%	0.0%	0.0%	0.0%	0.0%	0.0%	0.0%
Buses	0	16	0	16	0	0	0	0	0	0	0	0	3	0	0	3	0	0
% Buses	0.0%	4.4%	0.0%	4.4%	0.0%	0.0%	0.0%	0.0%	0.0%	0.0%	0.0%	0.0%	8.8%	0.0%	0.0%	8.8%	0.0%	0.0%
Pedestrians	0	0	0	0	0	0	0	0	0	0	0	0	0	0	0	0	1	4
% Pedestrians	0.0%	0.0%	0.0%	0.0%	0.0%	0.0%	0.0%	0.0%	0.0%	0.0%	0.0%	0.0%	0.0%	0.0%	0.0%	0.0%	50.0%	100.0%
Bicycles on Crosswalk	0	0	0	0	0	0	0	0	0	0	0	0	0	0	0	0	1	0
% Bicycles on Crosswalk	0.0%	0.0%	0.0%	0.0%	0.0%	0.0%	0.0%	0.0%	0.0%	0.0%	0.0%	0.0%	0.0%	0.0%	0.0%	0.0%	50.0%	0.0%

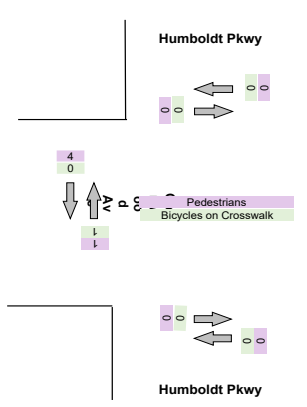
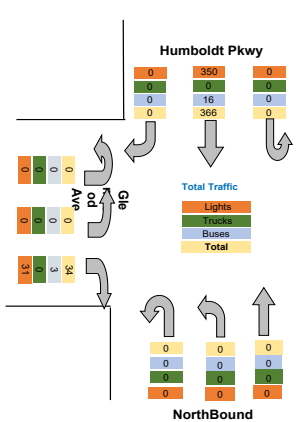

Turning Movement Peak Hour Data (PM)

4:15:00 PM

Leg Direction	Humboldt Pkwy Southbound						Humboldt Pkwy NorthBound						Glenwood Ave Eastbound					
	Right	Thru	U-Turn	App Total	Peds CW	Peds CCW	Thru	Left	U-Turn	App Total	Peds CW	Peds CCW	Right	Left	U-Turn	App Total	Peds CW	Peds CCW
4:15:00 PM	0	108	0	108	0	0	0	0	0	0	0	0	5	0	0	5	0	0
4:30:00 PM	0	119	0	119	0	0	0	0	0	0	0	0	6	0	0	6	0	3
4:45:00 PM	0	112	0	112	0	0	0	0	0	0	0	0	4	0	0	4	0	0
5:00:00 PM	0	109	0	109	0	0	0	0	0	0	0	0	8	0	0	8	0	1
<b>Grand Total</b>	0	448	0	448	0	0	0	0	0	0	0	0	23	0	0	23	0	4
% Approach	0.0%	100.0%	0.0%	0.0%	0.0%	0.0%	14.2%	0.0%	0.0%	0.0%	0.0%	0.0%	45.1%	41.7%	0.0%	0.0%	0.0%	0.0%
% Total	0.0%	95.1%	0.0%	95.1%	0.0%	0.0%	0.0%	0.0%	0.0%	0.0%	0.0%	0.0%	4.9%	0.0%	0.0%	4.9%	0.0%	0.0%
PHF	0.000	0.941	0.000	0.941	0.000	0.000	0.000	0.000	0.000	0.000	0.000	0.000	0.719	0.000	0.000	0.719	0.000	0.000
Lights	0	431	0	431	0	0	0	0	0	0	0	0	22	0	0	22	0	0
% Lights	0.0%	96.2%	0.0%	96.2%	0.0%	0.0%	0.0%	0.0%	0.0%	0.0%	0.0%	0.0%	95.7%	0.0%	0.0%	95.7%	0.0%	0.0%
Trucks	0	0	0	0	0	0	0	0	0	0	0	0	0	0	0	0	0	0
% Trucks	0.0%	0.0%	0.0%	0.0%	0.0%	0.0%	0.0%	0.0%	0.0%	0.0%	0.0%	0.0%	0.0%	0.0%	0.0%	0.0%	0.0%	0.0%
Buses	0	17	0	17	0	0	0	0	0	0	0	0	1	0	0	1	0	0
% Buses	0.0%	3.8%	0.0%	0.0%	0.0%	0.0%	0.0%	0.0%	0.0%	0.0%	0.0%	0.0%	4.3%	0.0%	0.0%	0.0%	0.0%	0.0%
Pedestrians	0	0	0	0	0	0	0	0	0	0	0	0	0	0	0	0	0	4
% Pedestrians	0.0%	0.0%	0.0%	0.0%	0.0%	0.0%	0.0%	0.0%	0.0%	0.0%	0.0%	0.0%	0.0%	0.0%	0.0%	0.0%	0.0%	100.0%
Bicycles on Crosswalk	0	0	0	0	0	0	0	0	0	0	0	0	0	0	0	0	0	0
% Bicycles on Crosswalk	0.0%	0.0%	0.0%	0.0%	0.0%	0.0%	0.0%	0.0%	0.0%	0.0%	0.0%	0.0%	0.0%	0.0%	0.0%	0.0%	0.0%	0.0%

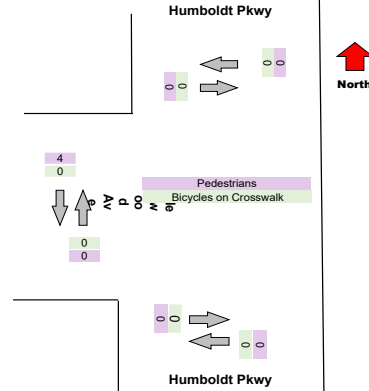
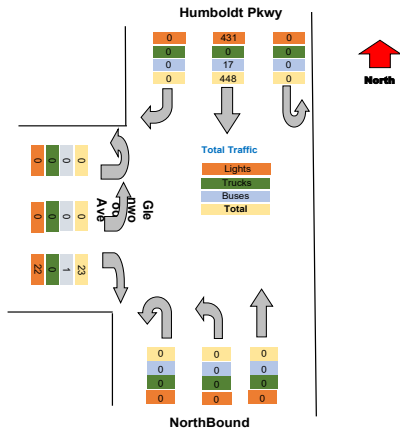

Intersection: Elm St Pine St  
 Location: Kennett Square, PA  
 Site: 01  
 Survey Date: Wednesday, 04-28-2021  
 GPS: 42.948550, -72.790034



<b>Total</b>
40
62
102
47
59
106
99
311
79
116
195
170
113
125
116
524
117
100
95
84
396
1528
0.0%
0.0%
1469
96.1%
0
0.0%
59
3.9%
0
0.0%
0.0%

Intersection: Elm St Pine St  
Location: Kennett Square, PA  
Site: 01  
Survey Date: Wednesday, 04-28-2021  
GPS: 42.948550, -72.790034



Total
106
99
79
116
400
0.862
381
95.3%
0
0.0%
19
4.8%
0
0.0%
0
0.0%

Intersection: Elm St Pine St  
Location: Kennett Square, PA  
Site: 01  
Survey Date: Wednesday, 04-28-2021  
GPS: 42.948550, -72.790034



Total
113
125
116
117
471
0.942
453
96.2%
0
0.0%
18
3.8%
0
0.0%
0
0.0%

Project	Labella
Project Code	Labella
Site Name	B
Legs and Movements	All Processed Legs & Movements
Bin Size	15 minutes
Survey Date	2021-10-27, Wednesday
Location	B
Latitude and Longitude	42.912267, -78.843718

	Start	End	PHF
Forced Peak AM	2021/10/27 07:30:00	2021/10/27 08:30:00	0.952
Forced Peak PM	2021/10/27 16:30:00	2021/10/27 17:30:00	0.877
AM Peak	2021/10/27 07:30:00	2021/10/27 08:30:00	0.952
PM Peak	2021/10/27 16:15:00	2021/10/27 17:15:00	0.873

Turning Movement Data

Leg Direction	Humboldt Pkwy Southbound						Humboldt Pkwy NorthBound						Glenwood Ave Eastbound											
	Right	Thru	U-Turn	App Total	Peds	CW	Peds	CCW	Thru	Left	U-Turn	App Total	Peds	CW	Peds	CCW	Right	Left	U-Turn	App Total	Peds	CW	Peds	CCW
Start Time	0	43	0	43	0	0	0	0	0	0	0	0	0	0	0	0	3	0	0	3	0	0	2	0
6:30:00 AM	0	50	0	50	0	0	0	0	0	0	0	0	0	0	0	0	3	0	0	3	0	0	2	0
6:45:00 AM	0	93	0	93	0	0	0	0	0	0	0	0	0	0	0	0	6	0	0	6	0	0	4	0
Hourly Total	0	93	0	93	0	0	0	0	0	0	0	0	0	0	0	0	6	0	0	6	0	0	4	0
7:00:00 AM	0	37	0	37	0	0	0	0	0	0	0	0	0	0	0	0	1	0	0	1	2	1	1	0
7:15:00 AM	0	61	0	61	0	0	0	0	0	0	0	0	0	0	0	0	4	0	0	4	0	0	0	0
7:30:00 AM	0	79	0	79	0	0	0	0	0	0	0	0	0	0	0	0	12	0	0	12	1	0	0	0
7:45:00 AM	0	99	0	99	0	0	0	0	0	0	0	0	0	0	0	0	5	0	0	5	0	1	1	0
Hourly Total	0	276	0	276	0	0	0	0	0	0	0	0	0	0	0	0	22	0	0	22	3	2	2	0
8:00:00 AM	0	93	0	93	0	0	0	0	0	0	0	0	0	0	0	0	4	0	0	4	1	0	0	0
8:15:00 AM	0	101	0	101	0	0	0	0	0	0	0	0	0	0	0	0	3	0	0	3	0	0	0	0
Hourly Total	0	194	0	194	0	0	0	0	0	0	0	0	0	0	0	0	7	0	0	7	1	0	0	0
4:00:00 PM	0	114	0	114	0	0	0	0	0	0	0	0	0	0	0	0	10	0	0	10	1	0	0	0
4:15:00 PM	0	108	0	108	0	0	0	0	0	0	0	0	0	0	0	0	5	0	0	5	2	0	0	0
4:30:00 PM	0	117	0	117	0	0	0	0	0	0	0	0	0	0	0	0	11	0	0	11	4	0	0	0
4:45:00 PM	0	84	0	84	0	0	0	0	0	0	0	0	0	0	0	0	9	0	0	9	0	0	0	0
Hourly Total	0	423	0	423	0	0	0	0	0	0	0	0	0	0	0	0	35	0	0	35	7	0	0	0
5:00:00 PM	0	110	0	110	0	0	0	0	0	0	0	0	0	0	0	0	3	0	0	3	1	1	1	0
5:15:00 PM	0	105	0	105	0	0	0	0	0	0	0	0	0	0	0	0	10	0	0	10	1	0	0	0
5:30:00 PM	0	94	0	94	0	0	0	0	0	0	0	0	0	0	0	0	3	0	0	3	0	0	0	0
5:45:00 PM	0	87	0	87	0	0	0	0	0	0	0	0	0	0	0	0	3	0	0	3	0	0	0	0
Hourly Total	0	396	0	396	0	0	0	0	0	0	0	0	0	0	0	0	19	0	0	19	2	1	1	0
Grand Total	0	1382	0	1382	0	0	0	0	0	0	0	0	0	0	0	0	89	0	0	89	13	7	7	0
% Approach	0.0%	100.0%	0.0%	0.0%	0.0%	0.0%	0.0%	0.0%	0.0%	0.0%	0.0%	0.0%	0.0%	0.0%	0.0%	0.0%	100.0%	0.0%	0.0%	0.0%	0.0%	0.0%	0.0%	0.0%
% Total	0.0%	93.9%	0.0%	93.9%	0.0%	0.0%	0.0%	0.0%	0.0%	0.0%	0.0%	0.0%	0.0%	0.0%	0.0%	0.0%	6.1%	0.0%	0.0%	6.1%	0.0%	0.0%	0.0%	0.0%
Lights	0	1333	0	1333	0	0	0	0	0	0	0	0	0	0	0	0	80	0	0	80	0	0	0	0
% Lights	0.0%	96.5%	0.0%	96.5%	0.0%	0.0%	0.0%	0.0%	0.0%	0.0%	0.0%	0.0%	0.0%	0.0%	0.0%	0.0%	89.9%	0.0%	0.0%	89.9%	0.0%	0.0%	0.0%	0.0%
Trucks	0	0	0	0	0	0	0	0	0	0	0	0	0	0	0	0	0	0	0	0	0	0	0	0
% Trucks	0.0%	0.0%	0.0%	0.0%	0.0%	0.0%	0.0%	0.0%	0.0%	0.0%	0.0%	0.0%	0.0%	0.0%	0.0%	0.0%	0.0%	0.0%	0.0%	0.0%	0.0%	0.0%	0.0%	0.0%
Buses	0	48	0	48	0	0	0	0	0	0	0	0	0	0	0	0	9	0	0	9	0	0	0	0
% Buses	0.0%	3.5%	0.0%	3.5%	0.0%	0.0%	0.0%	0.0%	0.0%	0.0%	0.0%	0.0%	0.0%	0.0%	0.0%	0.0%	10.1%	0.0%	0.0%	10.1%	0.0%	0.0%	0.0%	0.0%
Pedestrians	0	0	0	0	0	0	0	0	0	0	0	0	0	0	0	0	0	0	0	0	11	7	7	0
% Pedestrians	0.0%	0.0%	0.0%	0.0%	0.0%	0.0%	0.0%	0.0%	0.0%	0.0%	0.0%	0.0%	0.0%	0.0%	0.0%	0.0%	0.0%	0.0%	0.0%	0.0%	84.6%	100.0%	100.0%	0.0%
% Bicycles on Crosswalk	0.0%	0.0%	0.0%	0.0%	0.0%	0.0%	0.0%	0.0%	0.0%	0.0%	0.0%	0.0%	0.0%	0.0%	0.0%	0.0%	0.0%	0.0%	0.0%	0.0%	15.4%	0.0%	0.0%	0.0%

Turning Movement Data Plot

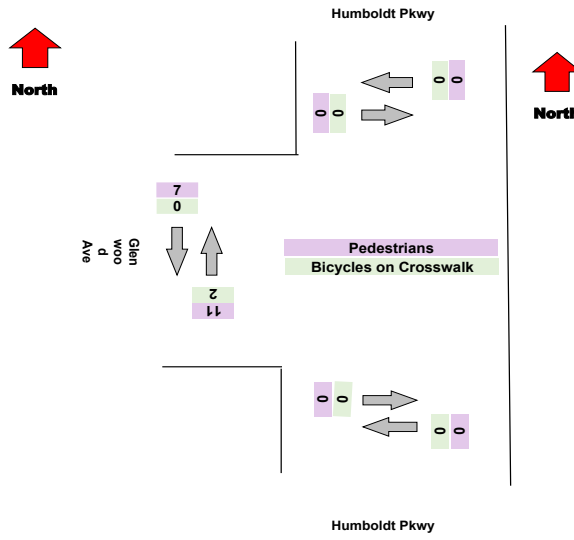
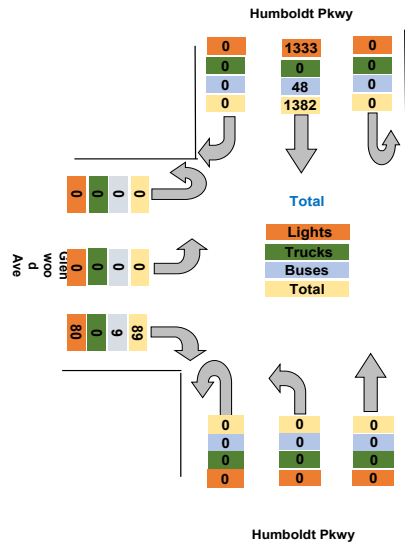



Turning Movement Peak Hour Data (AM)

7:30:00 AM

Leg Direction	Humboldt Pkwy Southbound						Humboldt Pkwy NorthBound						Glenwood Ave Eastbound					
	Right	Thru	U-Turn	App Total	Peds CW	Peds CCW	Thru	Left	U-Turn	App Total	Peds CW	Peds CCW	Right	Left	U-Turn	App Total	Peds CW	Peds CCW
7:30:00 AM	0	79	0	79	0	0	0	0	0	0	0	0	12	0	0	12	1	0
7:45:00 AM	0	99	0	99	0	0	0	0	0	0	0	0	5	0	0	5	0	1
8:00:00 AM	0	93	0	93	0	0	0	0	0	0	0	0	4	0	0	4	1	0
8:15:00 AM	0	101	0	101	0	0	0	0	0	0	0	0	3	0	0	3	0	0
<b>Grand Total</b>	0	372	0	372	0	0	0	0	0	0	0	0	24	0	0	24	2	1
% Approach	0.0%	100.0%	0.0%	0.0%	0.0%	0.0%	14.2%	0.0%	0.0%	0.0%	0.0%	0.0%	45.1%	41.7%	0.0%	0.0%	0.0%	0.0%
% Total	0.0%	93.9%	0.0%	93.9%	0.0%	0.0%	0.0%	0.0%	0.0%	0.0%	0.0%	0.0%	6.1%	0.0%	0.0%	6.1%	0.0%	0.0%
PHF	0.000	0.921	0.000	0.921	0.000	0.000	0.000	0.000	0.000	0.000	0.000	0.000	0.500	0.000	0.000	0.500	0.000	0.000
Lights	0	356	0	356	0	0	0	0	0	0	0	0	20	0	0	20	0	0
% Lights	0.0%	95.7%	0.0%	95.7%	0.0%	0.0%	0.0%	0.0%	0.0%	0.0%	0.0%	0.0%	83.3%	0.0%	0.0%	83.3%	0.0%	0.0%
Trucks	0	0	0	0	0	0	0	0	0	0	0	0	0	0	0	0	0	0
% Trucks	0.0%	0.0%	0.0%	0.0%	0.0%	0.0%	0.0%	0.0%	0.0%	0.0%	0.0%	0.0%	0.0%	0.0%	0.0%	0.0%	0.0%	0.0%
Buses	0	16	0	16	0	0	0	0	0	0	0	0	4	0	0	4	0	0
% Buses	0.0%	4.3%	0.0%	4.3%	0.0%	0.0%	0.0%	0.0%	0.0%	0.0%	0.0%	0.0%	16.7%	0.0%	0.0%	16.7%	0.0%	0.0%
Pedestrians	0	0	0	0	0	0	0	0	0	0	0	0	0	0	0	0	2	1
% Pedestrians	0.0%	0.0%	0.0%	0.0%	0.0%	0.0%	0.0%	0.0%	0.0%	0.0%	0.0%	0.0%	0.0%	0.0%	0.0%	0.0%	100.0%	100.0%
Bicycles on Crosswalk	0	0	0	0	0	0	0	0	0	0	0	0	0	0	0	0	0	0
% Bicycles on Crosswalk	0.0%	0.0%	0.0%	0.0%	0.0%	0.0%	0.0%	0.0%	0.0%	0.0%	0.0%	0.0%	0.0%	0.0%	0.0%	0.0%	0.0%	0.0%

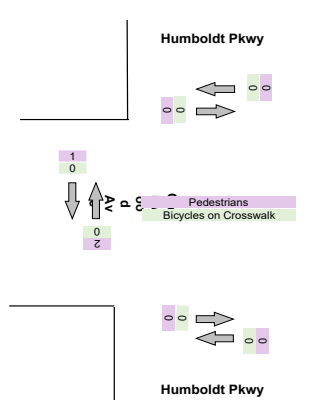
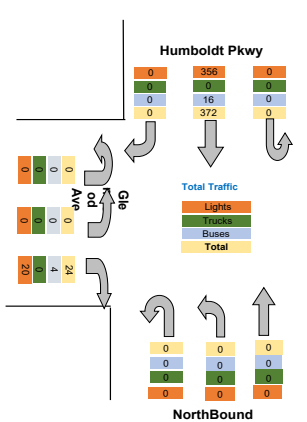

Turning Movement Peak Hour Data (PM)

4:15:00 PM

Leg Direction	Humboldt Pkwy Southbound						Humboldt Pkwy NorthBound						Glenwood Ave Eastbound					
	Right	Thru	U-Turn	App Total	Peds CW	Peds CCW	Thru	Left	U-Turn	App Total	Peds CW	Peds CCW	Right	Left	U-Turn	App Total	Peds CW	Peds CCW
4:15:00 PM	0	108	0	108	0	0	0	0	0	0	0	0	5	0	0	5	2	0
4:30:00 PM	0	117	0	117	0	0	0	0	0	0	0	0	11	0	0	11	4	0
4:45:00 PM	0	84	0	84	0	0	0	0	0	0	0	0	9	0	0	9	0	0
5:00:00 PM	0	110	0	110	0	0	0	0	0	0	0	0	3	0	0	3	1	1
<b>Grand Total</b>	0	419	0	419	0	0	0	0	0	0	0	0	28	0	0	28	7	1
% Approach	0.0%	100.0%	0.0%	0.0%	0.0%	0.0%	14.2%	0.0%	0.0%	0.0%	0.0%	0.0%	45.1%	41.7%	0.0%	0.0%	0.0%	0.0%
% Total	0.0%	93.7%	0.0%	93.7%	0.0%	0.0%	0.0%	0.0%	0.0%	0.0%	0.0%	0.0%	6.3%	0.0%	0.0%	6.3%	0.0%	0.0%
PHF	0.000	0.895	0.000	0.895	0.000	0.000	0.000	0.000	0.000	0.000	0.000	0.000	0.636	0.000	0.000	0.636	0.000	0.000
Lights	0	406	0	406	0	0	0	0	0	0	0	0	27	0	0	27	0	0
% Lights	0.0%	96.9%	0.0%	96.9%	0.0%	0.0%	0.0%	0.0%	0.0%	0.0%	0.0%	0.0%	96.4%	0.0%	0.0%	96.4%	0.0%	0.0%
Trucks	0	0	0	0	0	0	0	0	0	0	0	0	0	0	0	0	0	0
% Trucks	0.0%	0.0%	0.0%	0.0%	0.0%	0.0%	0.0%	0.0%	0.0%	0.0%	0.0%	0.0%	0.0%	0.0%	0.0%	0.0%	0.0%	0.0%
Buses	0	12	0	12	0	0	0	0	0	0	0	0	0	0	0	1	0	0
% Buses	0.0%	2.9%	0.0%	0.0%	0.0%	0.0%	0.0%	0.0%	0.0%	0.0%	0.0%	0.0%	3.6%	0.0%	0.0%	0.0%	0.0%	0.0%
Pedestrians	0	0	0	0	0	0	0	0	0	0	0	0	0	0	0	0	6	1
% Pedestrians	0.0%	0.0%	0.0%	0.0%	0.0%	0.0%	0.0%	0.0%	0.0%	0.0%	0.0%	0.0%	0.0%	0.0%	0.0%	0.0%	85.7%	100.0%
Bicycles on Crosswalk	0	0	0	0	0	0	0	0	0	0	0	0	0	0	0	0	1	0
% Bicycles on Crosswalk	0.0%	0.0%	0.0%	0.0%	0.0%	0.0%	0.0%	0.0%	0.0%	0.0%	0.0%	0.0%	0.0%	0.0%	0.0%	0.0%	14.3%	0.0%

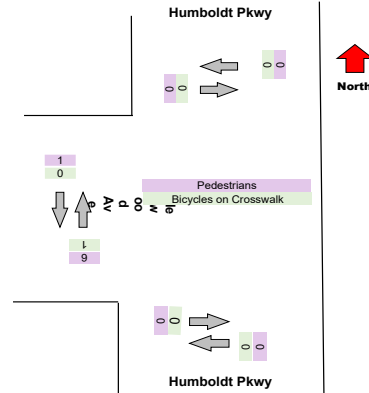
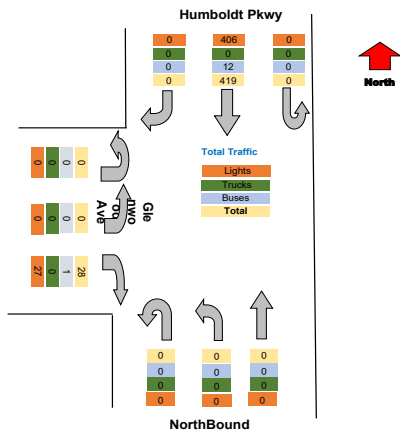

Intersection: Elm St Pine St  
 Location: Kennett Square, PA  
 Site: 01  
 Survey Date: Wednesday, 04-28-2021  
 GPS: 42.948550, -72.790034



<b>Total</b>
46
53
99
38
65
91
104
298
97
104
201
124
113
128
93
458
113
115
97
90
415
1471
0.0%
0.0%
1413
96.1%
0
0.0%
57
3.9%
0
0.0%
0.0%

Intersection: Elm St Pine St  
Location: Kennett Square, PA  
Site: 01  
Survey Date: Wednesday, 04-28-2021  
GPS: 42.948550, -72.790034



Total
91
104
97
104
396
0.952
376
94.9%
0
0.0%
20
5.1%
0
0.0%
0
0.0%

Intersection: Elm St Pine St  
Location: Kennett Square, PA  
Site: 01  
Survey Date: Wednesday, 04-28-2021  
GPS: 42.948550, -72.790034



Total
113
128
93
113
447
0.873
433
96.9%
0
0.0%
13
2.9%
0
0.0%
0
0.0%

Project	Labella
Project Code	Labella
Site Name	B
Legs and Movements	All Processed Legs & Movements
Bin Size	15 minutes
Survey Date	2021-10-28, Thursday
Location	B
Latitude and Longitude	42.912267, -78.843718

	Start	End	PHF
Forced Peak AM	2021/10/28 07:30:00	2021/10/28 08:30:00	0.807
Forced Peak PM	2021/10/28 16:30:00	2021/10/28 17:30:00	0.894
AM Peak	2021/10/28 07:30:00	2021/10/28 08:30:00	0.807
PM Peak	2021/10/28 16:15:00	2021/10/28 17:15:00	0.879

Turning Movement Data

Leg Direction	Humboldt Pkwy Southbound						Humboldt Pkwy NorthBound						Glenwood Ave Eastbound											
	Right	Thru	U-Turn	App Total	Peds	CW	Peds	CCW	Thru	Left	U-Turn	App Total	Peds	CW	Peds	CCW	Right	Left	U-Turn	App Total	Peds	CW	Peds	CCW
Start Time	0	37	0	37	0	0	0	0	0	0	0	0	0	0	0	0	4	0	0	4	0	0	2	2
6:30:00 AM	0	57	0	57	0	0	0	0	0	0	0	0	0	0	0	0	6	0	0	6	0	0	2	2
6:45:00 AM	0	94	0	94	0	0	0	0	0	0	0	0	0	0	0	0	10	0	0	10	0	0	4	4
Hourly Total	0	94	0	94	0	0	0	0	0	0	0	0	0	0	0	0	10	0	0	10	0	0	4	4
7:00:00 AM	0	37	0	37	0	0	0	0	0	0	0	0	0	0	0	0	6	0	0	6	1	1	1	1
7:15:00 AM	0	57	0	57	0	0	0	0	0	0	0	0	0	0	0	0	7	0	0	7	0	0	1	1
7:30:00 AM	0	85	0	85	0	0	0	0	0	0	0	0	0	0	0	0	11	0	0	11	2	1	1	1
7:45:00 AM	0	129	0	129	0	0	0	0	0	0	0	0	0	0	0	0	7	0	0	7	0	0	2	2
Hourly Total	0	308	0	308	0	0	0	0	0	0	0	0	0	0	0	0	31	0	0	31	3	5	5	5
8:00:00 AM	0	98	0	98	0	0	0	0	0	0	0	0	0	0	0	0	2	0	0	2	0	0	0	0
8:15:00 AM	0	100	0	100	0	0	0	0	0	0	0	0	0	0	0	0	7	0	0	7	0	0	0	0
Hourly Total	0	198	0	198	0	0	0	0	0	0	0	0	0	0	0	0	9	0	0	9	0	0	0	0
4:00:00 PM	0	128	0	128	0	0	0	0	0	0	0	0	0	0	0	0	8	0	0	8	0	0	0	0
4:15:00 PM	0	134	0	134	0	0	0	0	0	0	0	0	0	0	0	0	11	0	0	11	1	1	0	0
4:30:00 PM	0	128	0	128	0	0	0	0	0	0	0	0	0	0	0	0	4	0	0	4	0	0	0	0
4:45:00 PM	0	103	0	103	0	0	0	0	0	0	0	0	0	0	0	0	13	0	0	13	2	2	2	2
Hourly Total	0	493	0	493	0	0	0	0	0	0	0	0	0	0	0	0	36	0	0	36	3	2	2	2
5:00:00 PM	0	110	0	110	0	0	0	0	0	0	0	0	0	0	0	0	7	0	0	7	0	0	2	2
5:15:00 PM	0	103	0	103	0	0	0	0	0	0	0	0	0	0	0	0	4	0	0	4	2	3	3	3
5:30:00 PM	0	103	0	103	0	0	0	0	0	0	0	0	0	0	0	0	8	0	0	8	0	0	0	0
5:45:00 PM	0	107	0	107	0	0	0	0	0	0	0	0	0	0	0	0	5	0	0	5	3	1	1	1
Hourly Total	0	423	0	423	0	0	0	0	0	0	0	0	0	0	0	0	24	0	0	24	5	6	6	6
Grand Total	0	1516	0	1516	0	0	0	0	0	0	0	0	0	0	0	0	110	0	0	110	11	17	17	17
% Approach	0.0%	100.0%	0.0%	0.0%	0.0%	0.0%	0.0%	0.0%	0.0%	0.0%	0.0%	0.0%	0.0%	0.0%	0.0%	0.0%	100.0%	0.0%	0.0%	0.0%	0.0%	0.0%	0.0%	0.0%
% Total	0.0%	93.2%	0.0%	93.2%	0.0%	0.0%	0.0%	0.0%	0.0%	0.0%	0.0%	0.0%	0.0%	0.0%	0.0%	0.0%	6.8%	0.0%	0.0%	6.8%	0.0%	0.0%	0.0%	0.0%
Lights	0	1470	0	1470	0	0	0	0	0	0	0	0	0	0	0	0	101	0	0	101	0	0	0	0
% Lights	0.0%	97.0%	0.0%	97.0%	0.0%	0.0%	0.0%	0.0%	0.0%	0.0%	0.0%	0.0%	0.0%	0.0%	0.0%	0.0%	91.8%	0.0%	0.0%	91.8%	0.0%	0.0%	0.0%	0.0%
Trucks	0	1	0	1	0	0	0	0	0	0	0	0	0	0	0	0	0	0	0	0	0	0	0	0
% Trucks	0.0%	0.1%	0.0%	0.1%	0.0%	0.0%	0.0%	0.0%	0.0%	0.0%	0.0%	0.0%	0.0%	0.0%	0.0%	0.0%	0.0%	0.0%	0.0%	0.0%	0.0%	0.0%	0.0%	0.0%
Buses	0	44	0	44	0	0	0	0	0	0	0	0	0	0	0	0	9	0	0	9	0	0	0	0
% Buses	0.0%	2.9%	0.0%	0.0%	0.0%	0.0%	0.0%	0.0%	0.0%	0.0%	0.0%	0.0%	0.0%	0.0%	0.0%	0.0%	8.2%	0.0%	0.0%	0.0%	0.0%	0.0%	0.0%	0.0%
Pedestrians	0	0	0	0	0	0	0	0	0	0	0	0	0	0	0	0	0	0	0	0	10	16	16	16
% Pedestrians	0.0%	0.0%	0.0%	0.0%	0.0%	0.0%	0.0%	0.0%	0.0%	0.0%	0.0%	0.0%	0.0%	0.0%	0.0%	0.0%	0.0%	0.0%	0.0%	0.0%	90.9%	94.1%	94.1%	94.1%
% Bicycles on Crosswalk	0.0%	0.0%	0.0%	0.0%	0.0%	0.0%	0.0%	0.0%	0.0%	0.0%	0.0%	0.0%	0.0%	0.0%	0.0%	0.0%	0.0%	0.0%	0.0%	0.0%	9.1%	5.9%	5.9%	5.9%

Turning Movement Data Plot

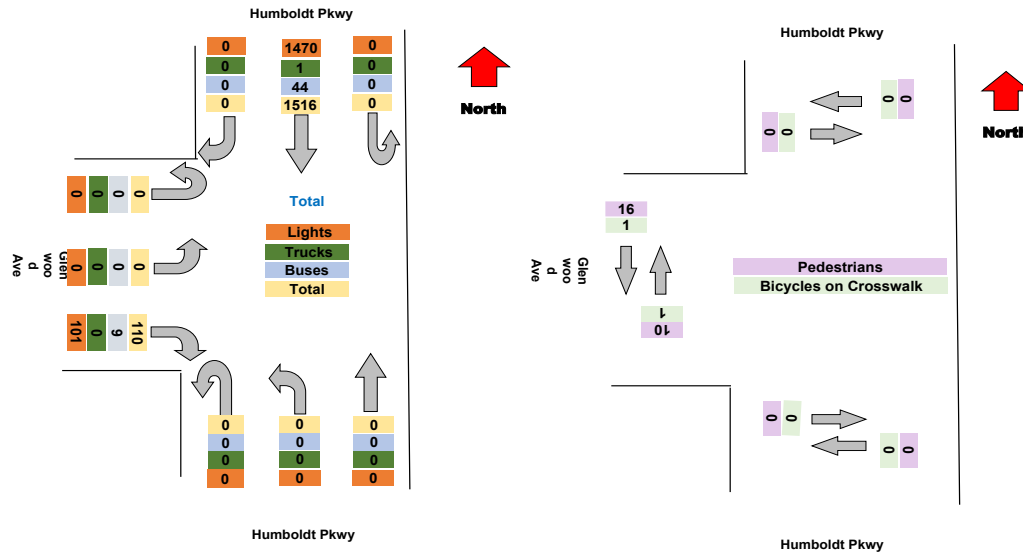

Turning Movement Peak Hour Data (AM)

7:30:00 AM

Leg Direction	Humboldt Pkwy Southbound						Humboldt Pkwy NorthBound						Glenwood Ave Eastbound					
	Right	Thru	U-Turn	App Total	Peds CW	Peds CCW	Thru	Left	U-Turn	App Total	Peds CW	Peds CCW	Right	Left	U-Turn	App Total	Peds CW	Peds CCW
7:30:00 AM	0	85	0	85	0	0	0	0	0	0	0	0	11	0	0	11	2	1
7:45:00 AM	0	129	0	129	0	0	0	0	0	0	0	0	7	0	0	7	0	2
8:00:00 AM	0	98	0	98	0	0	0	0	0	0	0	0	2	0	0	2	0	0
8:15:00 AM	0	100	0	100	0	0	0	0	0	0	0	0	7	0	0	7	0	0
<b>Grand Total</b>	0	412	0	412	0	0	0	0	0	0	0	0	27	0	0	27	2	3
% Approach	0.0%	100.0%	0.0%	0.0%	0.0%	0.0%	14.2%	0.0%	0.0%	0.0%	0.0%	0.0%	45.1%	41.7%	0.0%	0.0%	0.0%	0.0%
% Total	0.0%	93.8%	0.0%	93.8%	0.0%	0.0%	0.0%	0.0%	0.0%	0.0%	0.0%	0.0%	6.2%	0.0%	0.0%	6.2%	0.0%	0.0%
PHF	0.000	0.798	0.000	0.798	0.000	0.000	0.000	0.000	0.000	0.000	0.000	0.000	0.614	0.000	0.000	0.614	0.000	0.000
Lights	0	396	0	396	0	0	0	0	0	0	0	0	24	0	0	24	0	0
% Lights	0.0%	96.1%	0.0%	96.1%	0.0%	0.0%	0.0%	0.0%	0.0%	0.0%	0.0%	0.0%	88.9%	0.0%	0.0%	88.9%	0.0%	0.0%
Trucks	0	1	0	1	0	0	0	0	0	0	0	0	0	0	0	0	0	0
% Trucks	0.0%	0.2%	0.0%	0.2%	0.0%	0.0%	0.0%	0.0%	0.0%	0.0%	0.0%	0.0%	0.0%	0.0%	0.0%	0.0%	0.0%	0.0%
Buses	0	15	0	15	0	0	0	0	0	0	0	0	3	0	0	3	0	0
% Buses	0.0%	3.6%	0.0%	3.6%	0.0%	0.0%	0.0%	0.0%	0.0%	0.0%	0.0%	0.0%	11.1%	0.0%	0.0%	11.1%	0.0%	0.0%
Pedestrians	0	0	0	0	0	0	0	0	0	0	0	0	0	0	0	0	2	3
% Pedestrians	0.0%	0.0%	0.0%	0.0%	0.0%	0.0%	0.0%	0.0%	0.0%	0.0%	0.0%	0.0%	0.0%	0.0%	0.0%	0.0%	100.0%	100.0%
Bicycles on Crosswalk	0	0	0	0	0	0	0	0	0	0	0	0	0	0	0	0	0	0
% Bicycles on Crosswalk	0.0%	0.0%	0.0%	0.0%	0.0%	0.0%	0.0%	0.0%	0.0%	0.0%	0.0%	0.0%	0.0%	0.0%	0.0%	0.0%	0.0%	0.0%

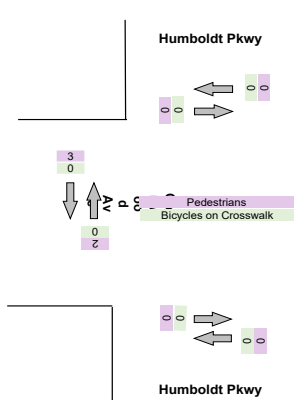
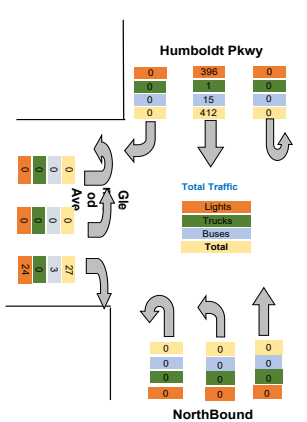



Turning Movement Peak Hour Data (PM)

4:15:00 PM

Leg Direction	Humboldt Pkwy Southbound						Humboldt Pkwy NorthBound						Glenwood Ave Eastbound					
	Right	Thru	U-Turn	App Total	Peds CW	Peds CCW	Thru	Left	U-Turn	App Total	Peds CW	Peds CCW	Right	Left	U-Turn	App Total	Peds CW	Peds CCW
4:15:00 PM	0	134	0	134	0	0	0	0	0	0	0	0	11	0	0	11	1	0
4:30:00 PM	0	128	0	128	0	0	0	0	0	0	0	0	4	0	0	4	0	0
4:45:00 PM	0	103	0	103	0	0	0	0	0	0	0	0	13	0	0	13	2	2
5:00:00 PM	0	110	0	110	0	0	0	0	0	0	0	0	7	0	0	7	0	2
<b>Grand Total</b>	0	475	0	475	0	0	0	0	0	0	0	0	35	0	0	35	3	4
% Approach	0.0%	100.0%	0.0%	0.0%	0.0%	0.0%	14.2%	0.0%	0.0%	0.0%	0.0%	0.0%	45.1%	41.7%	0.0%	0.0%	0.0%	0.0%
% Total	0.0%	93.1%	0.0%	93.1%	0.0%	0.0%	0.0%	0.0%	0.0%	0.0%	0.0%	0.0%	6.9%	0.0%	0.0%	6.9%	0.0%	0.0%
PHF	0.000	0.886	0.000	0.886	0.000	0.000	0.000	0.000	0.000	0.000	0.000	0.000	0.673	0.000	0.000	0.673	0.000	0.000
Lights	0	458	0	458	0	0	0	0	0	0	0	0	34	0	0	34	0	0
% Lights	0.0%	96.4%	0.0%	96.4%	0.0%	0.0%	0.0%	0.0%	0.0%	0.0%	0.0%	0.0%	97.1%	0.0%	0.0%	97.1%	0.0%	0.0%
Trucks	0	0	0	0	0	0	0	0	0	0	0	0	0	0	0	0	0	0
% Trucks	0.0%	0.0%	0.0%	0.0%	0.0%	0.0%	0.0%	0.0%	0.0%	0.0%	0.0%	0.0%	0.0%	0.0%	0.0%	0.0%	0.0%	0.0%
Buses	0	16	0	16	0	0	0	0	0	0	0	0	1	0	0	1	0	0
% Buses	0.0%	3.4%	0.0%	0.0%	0.0%	0.0%	0.0%	0.0%	0.0%	0.0%	0.0%	0.0%	2.9%	0.0%	0.0%	0.0%	0.0%	0.0%
Pedestrians	0	0	0	0	0	0	0	0	0	0	0	0	0	0	0	0	2	3
% Pedestrians	0.0%	0.0%	0.0%	0.0%	0.0%	0.0%	0.0%	0.0%	0.0%	0.0%	0.0%	0.0%	0.0%	0.0%	0.0%	0.0%	66.7%	75.0%
Bicycles on Crosswalk	0	0	0	0	0	0	0	0	0	0	0	0	0	0	0	0	1	1
% Bicycles on Crosswalk	0.0%	0.0%	0.0%	0.0%	0.0%	0.0%	0.0%	0.0%	0.0%	0.0%	0.0%	0.0%	0.0%	0.0%	0.0%	0.0%	33.3%	25.0%

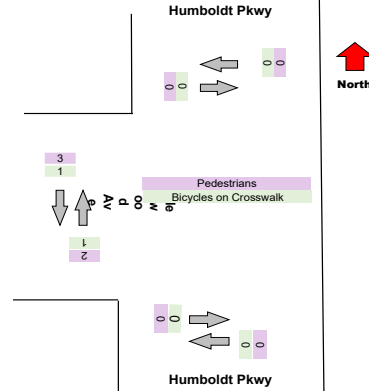
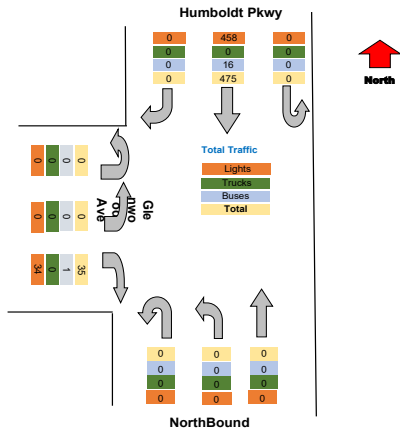

Intersection: Elm St Pine St  
 Location: Kennett Square, PA  
 Site: 01  
 Survey Date: Wednesday, 04-28-2021  
 GPS: 42.948550, -72.790034



<b>Total</b>
41
63
104
43
64
96
136
339
100
107
207
136
145
132
116
529
117
107
111
112
447
1626
0.0%
0.0%
1571
96.6%
1
0.1%
53
3.3%
0
0.0%
0.0%

Intersection: Elm St Pine St  
Location: Kennett Square, PA  
Site: 01  
Survey Date: Wednesday, 04-28-2021  
GPS: 42.948550, -72.790034



Total
96
136
100
107
439
0.807
420
95.7%
1
0.2%
18
4.1%
0
0.0%
0
0.0%

Intersection: Elm St Pine St  
Location: Kennett Square, PA  
Site: 01  
Survey Date: Wednesday, 04-28-2021  
GPS: 42.948550, -72.790034

Total
145
132
116
117
510
0.879
492
96.5%
0
0.0%
17
3.3%
0
0.0%
0
0.0%



Turning Movement Data Plot

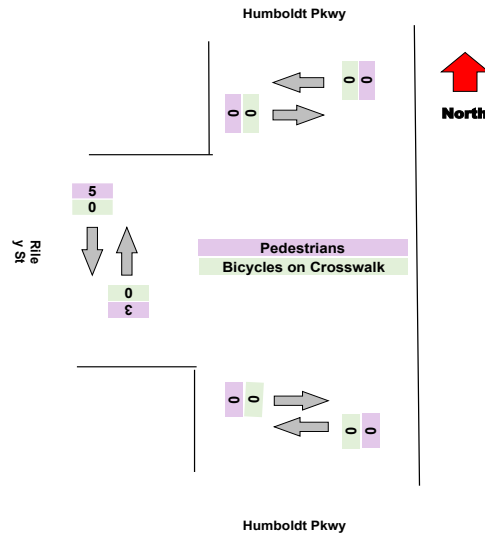
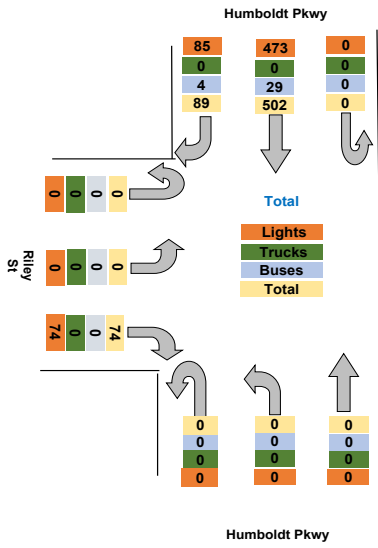

Turning Movement Peak Hour Data (AM)

7:30:00 AM

Leg Direction	Humboldt Pkwy Southbound						Humboldt Pkwy NorthBound						Riley St Eastbound						Total	
	Right	Thru	U-Turn	App Total	Peds CW	Peds CCW	Thru	Left	U-Turn	App Total	Peds CW	Peds CCW	Right	Left	U-Turn	App Total	Peds CW	Peds CCW		
7:30:00 AM	9	27	0	36	0	0	0	0	0	0	0	0	0	0	0	0	0	0	0	36
7:45:00 AM	2	31	0	33	0	0	0	0	0	0	0	0	4	0	0	4	0	0	0	37
8:00:00 AM	3	23	0	26	0	0	0	0	0	0	0	0	5	0	0	5	1	1	1	31
8:15:00 AM	8	29	0	37	0	0	0	0	0	0	0	0	4	0	0	4	0	2	2	41
<b>Grand Total</b>	<b>22</b>	<b>110</b>	<b>0</b>	<b>132</b>	<b>0</b>	<b>0</b>	<b>0</b>	<b>0</b>	<b>0</b>	<b>0</b>	<b>0</b>	<b>0</b>	<b>13</b>	<b>0</b>	<b>0</b>	<b>13</b>	<b>1</b>	<b>3</b>	<b>145</b>	
% Approach	16.7%	83.3%	0.0%	0.0%	0.0%	0.0%	14.2%	0.0%	0.0%	0.0%	0.0%	0.0%	45.1%	41.7%	0.0%	0.0%	0.0%	0.0%	0.0%	0.0%
% Total	15.2%	75.9%	0.0%	91.0%	0.0%	0.0%	0.0%	0.0%	0.0%	0.0%	0.0%	0.0%	9.0%	0.0%	0.0%	9.0%	0.0%	0.0%	0.0%	0.0%
PHF	0.611	0.887	0.000	0.892	0.000	0.000	0.000	0.000	0.000	0.000	0.000	0.000	0.650	0.000	0.000	0.650	0.000	0.000	0.000	0.884
Lights	21	102	0	123	0	0	0	0	0	0	0	0	13	0	0	13	0	0	0	136
% Lights	95.5%	92.7%	0.0%	93.2%	0.0%	0.0%	0.0%	0.0%	0.0%	0.0%	0.0%	0.0%	#####	0.0%	0.0%	100.0%	0.0%	0.0%	0.0%	93.8%
Trucks	0	0	0	0	0	0	0	0	0	0	0	0	0	0	0	0	0	0	0	0
% Trucks	0.0%	0.0%	0.0%	0.0%	0.0%	0.0%	0.0%	0.0%	0.0%	0.0%	0.0%	0.0%	0.0%	0.0%	0.0%	0.0%	0.0%	0.0%	0.0%	0.0%
Buses	1	8	0	9	0	0	0	0	0	0	0	0	0	0	0	0	0	0	0	9
% Buses	4.5%	7.3%	0.0%	0.0%	0.0%	0.0%	0.0%	0.0%	0.0%	0.0%	0.0%	0.0%	0.0%	0.0%	0.0%	0.0%	0.0%	0.0%	0.0%	6.2%
Pedestrians	0	0	0	0	0	0	0	0	0	0	0	0	0	0	0	0	1	3	0	0
% Pedestrians	0.0%	0.0%	0.0%	0.0%	0.0%	0.0%	0.0%	0.0%	0.0%	0.0%	0.0%	0.0%	0.0%	0.0%	0.0%	0.0%	100.0%	100.0%	0.0%	0.0%
Bicycles on Crosswalk	0	0	0	0	0	0	0	0	0	0	0	0	0	0	0	0	0	0	0	0
% Bicycles on Crosswalk	0.0%	0.0%	0.0%	0.0%	0.0%	0.0%	0.0%	0.0%	0.0%	0.0%	0.0%	0.0%	0.0%	0.0%	0.0%	0.0%	0.0%	0.0%	0.0%	0.0%

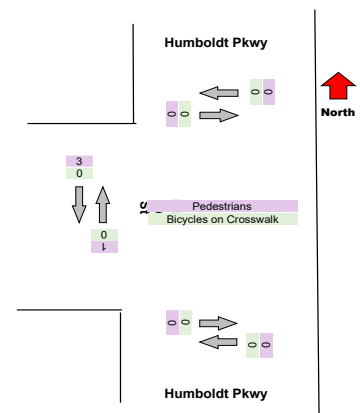
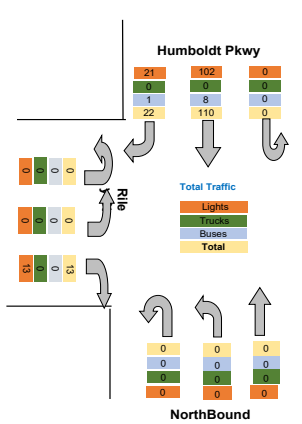

Turning Movement Peak Hour Data (PM)

4:15:00 PM

Leg Direction	Humboldt Pkwy Southbound						Humboldt Pkwy NorthBound						Riley St Eastbound						Total
	Right	Thru	U-Turn	App Total	Peds CW	Peds CCW	Thru	Left	U-Turn	App Total	Peds CW	Peds CCW	Right	Left	U-Turn	App Total	Peds CW	Peds CCW	
4:15:00 PM	5	46	0	51	0	0	0	0	0	0	0	0	6	0	0	6	0	0	57
4:30:00 PM	7	41	0	48	0	0	0	0	0	0	0	0	10	0	0	10	0	0	58
4:45:00 PM	9	36	0	45	0	0	0	0	0	0	0	0	10	0	0	10	2	0	55
5:00:00 PM	7	38	0	45	0	0	0	0	0	0	0	0	3	0	0	3	0	1	48
<b>Grand Total</b>	28	161	0	189	0	0	0	0	0	0	0	0	29	0	0	29	2	1	218
% Approach	14.8%	85.2%	0.0%	0.0%	0.0%	0.0%	14.2%	0.0%	0.0%	0.0%	0.0%	0.0%	45.1%	41.7%	0.0%	0.0%	0.0%	0.0%	0.0%
% Total	12.8%	73.9%	0.0%	86.7%	0.0%	0.0%	0.0%	0.0%	0.0%	0.0%	0.0%	0.0%	13.3%	0.0%	0.0%	13.3%	0.0%	0.0%	0.0%
PHF	0.778	0.875	0.000	0.926	0.000	0.000	0.000	0.000	0.000	0.000	0.000	0.000	0.725	0.000	0.000	0.725	0.000	0.000	0.940
Lights	26	153	0	179	0	0	0	0	0	0	0	0	29	0	0	29	0	0	208
% Lights	92.9%	95.0%	0.0%	94.7%	0.0%	0.0%	0.0%	0.0%	0.0%	0.0%	0.0%	0.0%	#####	0.0%	0.0%	100.0%	0.0%	0.0%	95.4%
Trucks	0	0	0	0	0	0	0	0	0	0	0	0	0	0	0	0	0	0	0
% Trucks	0.0%	0.0%	0.0%	0.0%	0.0%	0.0%	0.0%	0.0%	0.0%	0.0%	0.0%	0.0%	0.0%	0.0%	0.0%	0.0%	0.0%	0.0%	0.0%
Buses	2	8	0	10	0	0	0	0	0	0	0	0	0	0	0	0	0	0	10
% Buses	7.1%	5.0%	0.0%	0.0%	0.0%	0.0%	0.0%	0.0%	0.0%	0.0%	0.0%	0.0%	0.0%	0.0%	0.0%	0.0%	0.0%	0.0%	4.6%
Pedestrians	0	0	0	0	0	0	0	0	0	0	0	0	0	0	0	0	2	1	0
% Pedestrians	0.0%	0.0%	0.0%	0.0%	0.0%	0.0%	0.0%	0.0%	0.0%	0.0%	0.0%	0.0%	0.0%	0.0%	0.0%	0.0%	100.0%	100.0%	0.0%
Bicycles on Crosswalk	0	0	0	0	0	0	0	0	0	0	0	0	0	0	0	0	0	0	0
% Bicycles on Crosswalk	0.0%	0.0%	0.0%	0.0%	0.0%	0.0%	0.0%	0.0%	0.0%	0.0%	0.0%	0.0%	0.0%	0.0%	0.0%	0.0%	0.0%	0.0%	0.0%

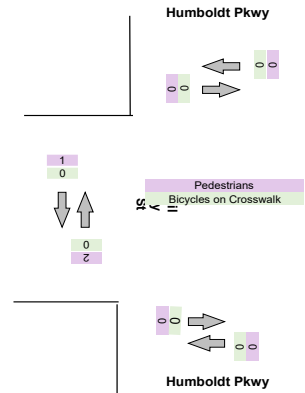
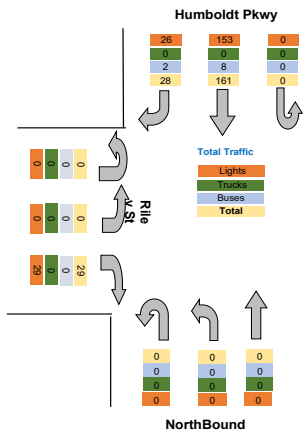





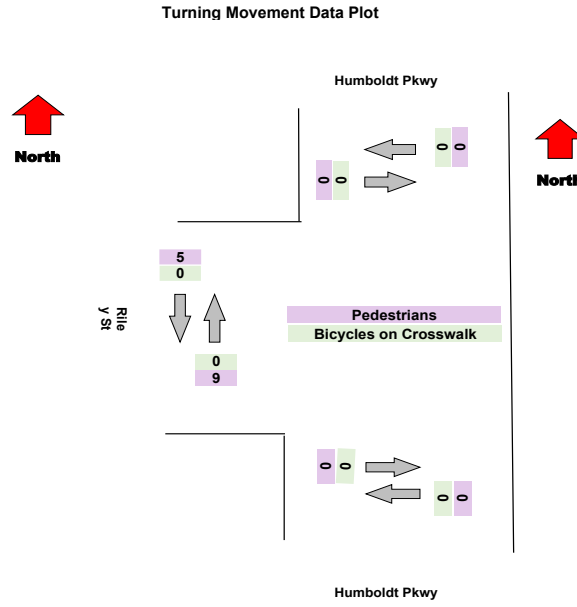
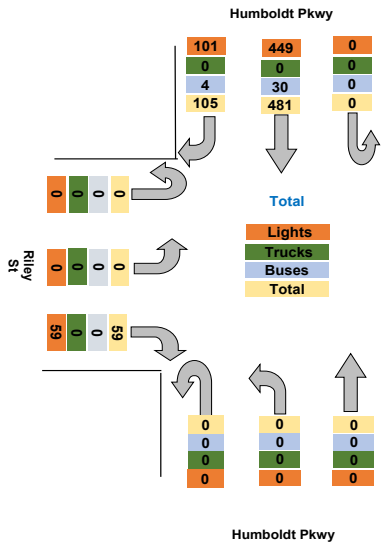

Turning Movement Peak Hour Data (AM)

7:30:00 AM

Leg Direction	Humboldt Pkwy Southbound						Humboldt Pkwy NorthBound						Riley St Eastbound					
	Right	Thru	U-Turn	App Total	Peds CW	Peds CCW	Thru	Left	U-Turn	App Total	Peds CW	Peds CCW	Right	Left	U-Turn	App Total	Peds CW	Peds CCW
7:30:00 AM	7	13	0	20	0	0	0	0	0	0	0	1	0	0	1	0	0	0
7:45:00 AM	3	38	0	41	0	0	0	0	0	0	0	2	0	0	2	0	0	0
8:00:00 AM	6	33	0	39	0	0	0	0	0	0	0	6	0	0	6	1	0	0
8:15:00 AM	12	29	0	41	0	0	0	0	0	0	0	6	0	0	6	0	0	0
<b>Grand Total</b>	28	113	0	141	0	0	0	0	0	0	0	15	0	0	15	1	0	0
% Approach	19.9%	80.1%	0.0%	0.0%	0.0%	0.0%	14.2%	0.0%	0.0%	0.0%	0.0%	45.1%	41.7%	0.0%	0.0%	0.0%	0.0%	0.0%
% Total	17.9%	72.4%	0.0%	90.4%	0.0%	0.0%	0.0%	0.0%	0.0%	0.0%	0.0%	9.6%	0.0%	0.0%	9.6%	0.0%	0.0%	0.0%
PHF	0.583	0.743	0.000	0.860	0.000	0.000	0.000	0.000	0.000	0.000	0.000	0.625	0.000	0.000	0.625	0.000	0.000	0.000
Lights	28	106	0	134	0	0	0	0	0	0	0	15	0	0	15	0	0	0
% Lights	100.0%	93.8%	0.0%	95.0%	0.0%	0.0%	0.0%	0.0%	0.0%	0.0%	0.0%	100.0%	0.0%	0.0%	100.0%	0.0%	0.0%	0.0%
Trucks	0	0	0	0	0	0	0	0	0	0	0	0	0	0	0	0	0	0
% Trucks	0.0%	0.0%	0.0%	0.0%	0.0%	0.0%	0.0%	0.0%	0.0%	0.0%	0.0%	0.0%	0.0%	0.0%	0.0%	0.0%	0.0%	0.0%
Buses	0	7	0	7	0	0	0	0	0	0	0	0	0	0	0	0	0	0
% Buses	0.0%	6.2%	0.0%	0.0%	0.0%	0.0%	0.0%	0.0%	0.0%	0.0%	0.0%	0.0%	0.0%	0.0%	0.0%	0.0%	0.0%	0.0%
Pedestrians	0	0	0	0	0	0	0	0	0	0	0	0	0	0	0	1	0	0
% Pedestrians	0.0%	0.0%	0.0%	0.0%	0.0%	0.0%	0.0%	0.0%	0.0%	0.0%	0.0%	0.0%	0.0%	0.0%	0.0%	100.0%	0.0%	0.0%
Bicycles on Crosswalk	0	0	0	0	0	0	0	0	0	0	0	0	0	0	0	0	0	0
% Bicycles on Crosswalk	0.0%	0.0%	0.0%	0.0%	0.0%	0.0%	0.0%	0.0%	0.0%	0.0%	0.0%	0.0%	0.0%	0.0%	0.0%	0.0%	0.0%	0.0%

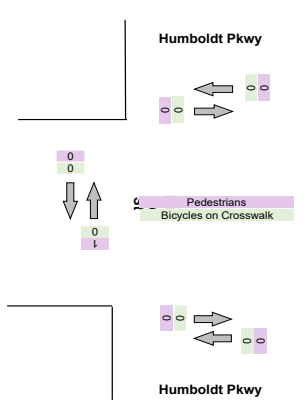
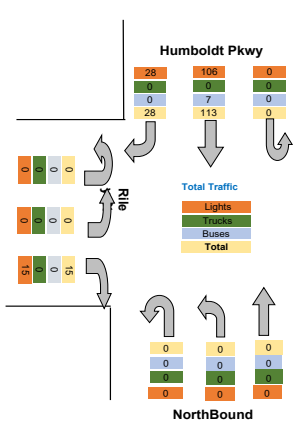

Turning Movement Peak Hour Data (PM)

4:15:00 PM

Leg Direction	Humboldt Pkwy Southbound						Humboldt Pkwy NorthBound						Riley St Eastbound					
	Right	Thru	U-Turn	App Total	Peds CW	Peds CCW	Thru	Left	U-Turn	App Total	Peds CW	Peds CCW	Right	Left	U-Turn	App Total	Peds CW	Peds CCW
4:15:00 PM	2	44	0	46	0	0	0	0	0	0	0	0	4	0	0	4	0	0
4:30:00 PM	8	47	0	55	0	0	0	0	0	0	0	0	6	0	0	6	0	0
4:45:00 PM	8	37	0	45	0	0	0	0	0	0	0	0	2	0	0	2	0	1
5:00:00 PM	13	30	0	43	0	0	0	0	0	0	0	0	4	0	0	4	0	0
<b>Grand Total</b>	<b>31</b>	<b>158</b>	<b>0</b>	<b>189</b>	<b>0</b>	<b>0</b>	<b>0</b>	<b>0</b>	<b>0</b>	<b>0</b>	<b>0</b>	<b>0</b>	<b>16</b>	<b>0</b>	<b>0</b>	<b>16</b>	<b>0</b>	<b>1</b>
% Approach	16.4%	83.6%	0.0%	0.0%	0.0%	0.0%	14.2%	0.0%	0.0%	0.0%	0.0%	0.0%	45.1%	41.7%	0.0%	0.0%	0.0%	0.0%
% Total	15.1%	77.1%	0.0%	92.2%	0.0%	0.0%	0.0%	0.0%	0.0%	0.0%	0.0%	0.0%	7.8%	0.0%	0.0%	7.8%	0.0%	0.0%
PHF	0.596	0.840	0.000	0.859	0.000	0.000	0.000	0.000	0.000	0.000	0.000	0.000	0.667	0.000	0.000	0.667	0.000	0.000
Lights	29	147	0	176	0	0	0	0	0	0	0	0	16	0	0	16	0	0
% Lights	93.5%	93.0%	0.0%	93.1%	0.0%	0.0%	0.0%	0.0%	0.0%	0.0%	0.0%	0.0%	100.0%	0.0%	0.0%	100.0%	0.0%	0.0%
Trucks	0	0	0	0	0	0	0	0	0	0	0	0	0	0	0	0	0	0
% Trucks	0.0%	0.0%	0.0%	0.0%	0.0%	0.0%	0.0%	0.0%	0.0%	0.0%	0.0%	0.0%	0.0%	0.0%	0.0%	0.0%	0.0%	0.0%
Buses	2	10	0	12	0	0	0	0	0	0	0	0	0	0	0	0	0	0
% Buses	6.5%	6.3%	0.0%	6.0%	0.0%	0.0%	0.0%	0.0%	0.0%	0.0%	0.0%	0.0%	0.0%	0.0%	0.0%	0.0%	0.0%	0.0%
Pedestrians	0	0	0	0	0	0	0	0	0	0	0	0	0	0	0	0	0	1
% Pedestrians	0.0%	0.0%	0.0%	0.0%	0.0%	0.0%	0.0%	0.0%	0.0%	0.0%	0.0%	0.0%	0.0%	0.0%	0.0%	0.0%	0.0%	100.0%
Bicycles on Crosswalk	0	0	0	0	0	0	0	0	0	0	0	0	0	0	0	0	0	0
% Bicycles on Crosswalk	0.0%	0.0%	0.0%	0.0%	0.0%	0.0%	0.0%	0.0%	0.0%	0.0%	0.0%	0.0%	0.0%	0.0%	0.0%	0.0%	0.0%	0.0%

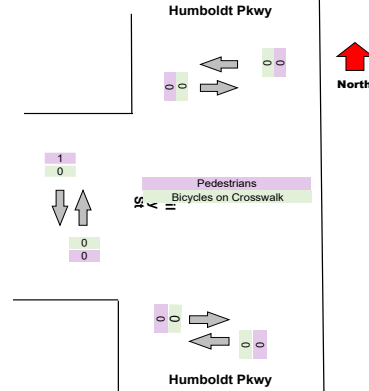
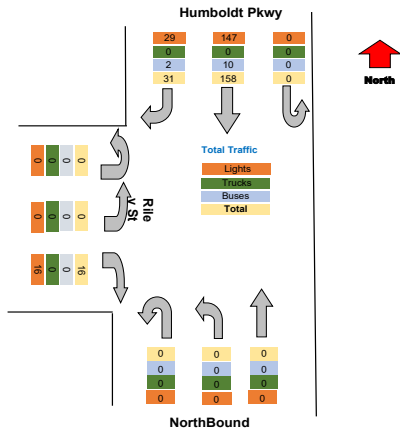

Intersection: Elm St Pine St  
 Location: Kennett Square, PA  
 Site: 01  
 Survey Date: Wednesday, 04-28-2021  
 GPS: 42.948550, -72.790034



<b>Total</b>
12
31
43
22
23
21
43
109
45
47
92
56
50
61
47
214
47
50
49
41
187
645
0.0%
0.0%
609
94.4%
0
0.0%
34
5.3%
0
0.0%
0.0%

Intersection: Elm St Pine St  
Location: Kennett Square, PA  
Site: 01  
Survey Date: Wednesday, 04-28-2021  
GPS: 42.948550, -72.790034



Total
21
43
45
47
156
0.830
149
95.5%
0
0.0%
7
4.5%
0
0.0%
0
0.0%

Intersection: Elm St Pine St  
Location: Kennett Square, PA  
Site: 01  
Survey Date: Wednesday, 04-28-2021  
GPS: 42.948550, -72.790034



Total
50
61
47
47
205
0.840
192
93.7%
0
0.0%
12
5.9%
0
0.0%
0
0.0%





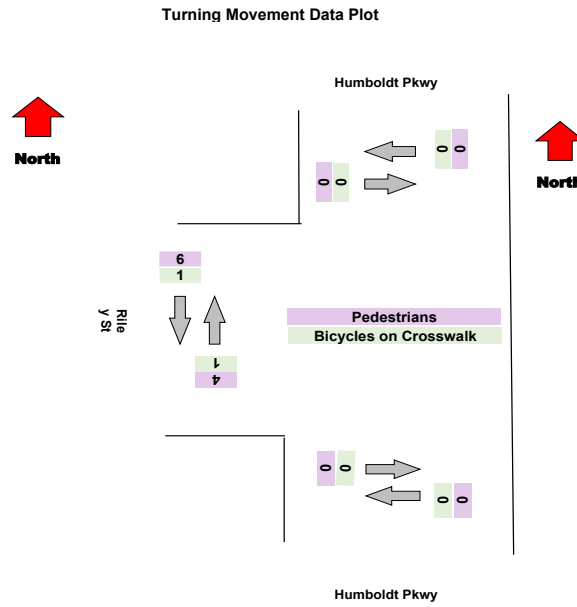
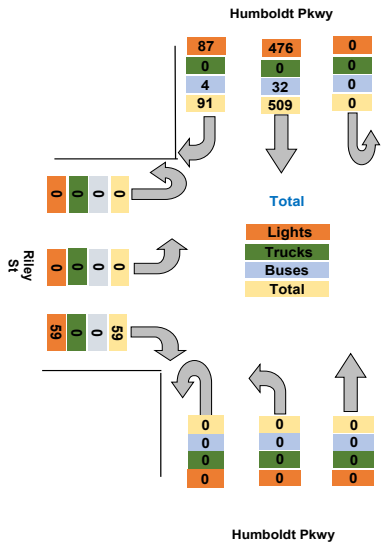

Turning Movement Peak Hour Data (AM)

7:30:00 AM

Leg Direction	Humboldt Pkwy Southbound						Humboldt Pkwy NorthBound						Riley St Eastbound					
	Right	Thru	U-Turn	App Total	Peds CW	Peds CCW	Thru	Left	U-Turn	App Total	Peds CW	Peds CCW	Right	Left	U-Turn	App Total	Peds CW	Peds CCW
7:30:00 AM	4	21	0	25	0	0	0	0	0	0	0	0	2	0	0	2	0	0
7:45:00 AM	9	49	0	58	0	0	0	0	0	0	0	0	2	0	0	2	0	0
8:00:00 AM	5	33	0	38	0	0	0	0	0	0	0	0	5	0	0	5	0	0
8:15:00 AM	7	38	0	45	0	0	0	0	0	0	0	0	2	0	0	2	0	0
<b>Grand Total</b>	25	141	0	166	0	0	0	0	0	0	0	0	11	0	0	11	0	0
% Approach	15.1%	84.9%	0.0%	0.0%	0.0%	0.0%	14.2%	0.0%	0.0%	0.0%	0.0%	0.0%	45.1%	41.7%	0.0%	0.0%	0.0%	0.0%
% Total	14.1%	79.7%	0.0%	93.8%	0.0%	0.0%	0.0%	0.0%	0.0%	0.0%	0.0%	0.0%	6.2%	0.0%	0.0%	6.2%	0.0%	0.0%
PHF	0.694	0.719	0.000	0.716	0.000	0.000	0.000	0.000	0.000	0.000	0.000	0.000	0.550	0.000	0.000	0.550	0.000	0.000
Lights	25	131	0	156	0	0	0	0	0	0	0	0	11	0	0	11	0	0
% Lights	100.0%	92.9%	0.0%	94.0%	0.0%	0.0%	0.0%	0.0%	0.0%	0.0%	0.0%	0.0%	100.0%	0.0%	0.0%	100.0%	0.0%	0.0%
Trucks	0	0	0	0	0	0	0	0	0	0	0	0	0	0	0	0	0	0
% Trucks	0.0%	0.0%	0.0%	0.0%	0.0%	0.0%	0.0%	0.0%	0.0%	0.0%	0.0%	0.0%	0.0%	0.0%	0.0%	0.0%	0.0%	0.0%
Buses	0	10	0	10	0	0	0	0	0	0	0	0	0	0	0	0	0	0
% Buses	0.0%	7.1%	0.0%	0.0%	0.0%	0.0%	0.0%	0.0%	0.0%	0.0%	0.0%	0.0%	0.0%	0.0%	0.0%	0.0%	0.0%	0.0%
Pedestrians	0	0	0	0	0	0	0	0	0	0	0	0	0	0	0	0	0	0
% Pedestrians	0.0%	0.0%	0.0%	0.0%	0.0%	0.0%	0.0%	0.0%	0.0%	0.0%	0.0%	0.0%	0.0%	0.0%	0.0%	0.0%	0.0%	0.0%
Bicycles on Crosswalk	0	0	0	0	0	0	0	0	0	0	0	0	0	0	0	0	0	0
% Bicycles on Crosswalk	0.0%	0.0%	0.0%	0.0%	0.0%	0.0%	0.0%	0.0%	0.0%	0.0%	0.0%	0.0%	0.0%	0.0%	0.0%	0.0%	0.0%	0.0%

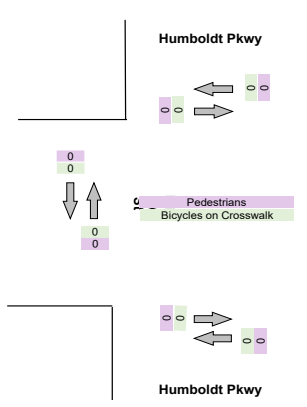
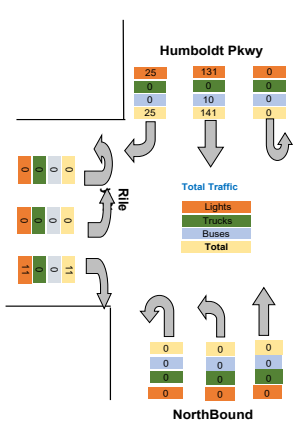

Turning Movement Peak Hour Data (PM)

4:15:00 PM

Leg Direction	Humboldt Pkwy Southbound						Humboldt Pkwy NorthBound						Riley St Eastbound					
	Right	Thru	U-Turn	App Total	Peds CW	Peds CCW	Thru	Left	U-Turn	App Total	Peds CW	Peds CCW	Right	Left	U-Turn	App Total	Peds CW	Peds CCW
4:15:00 PM	9	48	0	57	0	0	0	0	0	0	0	0	7	0	0	7	3	0
4:30:00 PM	8	41	0	49	0	0	0	0	0	0	0	0	3	0	0	3	0	1
4:45:00 PM	10	27	0	37	0	0	0	0	0	0	0	0	7	0	0	7	0	0
5:00:00 PM	3	39	0	42	0	0	0	0	0	0	0	0	10	0	0	10	1	1
<b>Grand Total</b>	<b>30</b>	<b>155</b>	<b>0</b>	<b>185</b>	<b>0</b>	<b>0</b>	<b>0</b>	<b>0</b>	<b>0</b>	<b>0</b>	<b>0</b>	<b>0</b>	<b>27</b>	<b>0</b>	<b>0</b>	<b>27</b>	<b>4</b>	<b>2</b>
% Approach	16.2%	83.8%	0.0%	0.0%	0.0%	0.0%	14.2%	0.0%	0.0%	0.0%	0.0%	0.0%	45.1%	41.7%	0.0%	0.0%	0.0%	0.0%
% Total	14.2%	73.1%	0.0%	87.3%	0.0%	0.0%	0.0%	0.0%	0.0%	0.0%	0.0%	0.0%	12.7%	0.0%	0.0%	12.7%	0.0%	0.0%
PHF	0.750	0.807	0.000	0.811	0.000	0.000	0.000	0.000	0.000	0.000	0.000	0.000	0.675	0.000	0.000	0.675	0.000	0.000
Lights	29	145	0	174	0	0	0	0	0	0	0	0	27	0	0	27	0	0
% Lights	96.7%	93.5%	0.0%	94.1%	0.0%	0.0%	0.0%	0.0%	0.0%	0.0%	0.0%	0.0%	100.0%	0.0%	0.0%	100.0%	0.0%	0.0%
Trucks	0	0	0	0	0	0	0	0	0	0	0	0	0	0	0	0	0	0
% Trucks	0.0%	0.0%	0.0%	0.0%	0.0%	0.0%	0.0%	0.0%	0.0%	0.0%	0.0%	0.0%	0.0%	0.0%	0.0%	0.0%	0.0%	0.0%
Buses	1	9	0	10	0	0	0	0	0	0	0	0	0	0	0	0	0	0
% Buses	3.3%	5.8%	0.0%	0.0%	0.0%	0.0%	0.0%	0.0%	0.0%	0.0%	0.0%	0.0%	0.0%	0.0%	0.0%	0.0%	0.0%	0.0%
Pedestrians	0	0	0	0	0	0	0	0	0	0	0	0	0	0	0	0	3	1
% Pedestrians	0.0%	0.0%	0.0%	0.0%	0.0%	0.0%	0.0%	0.0%	0.0%	0.0%	0.0%	0.0%	0.0%	0.0%	0.0%	0.0%	75.0%	50.0%
Bicycles on Crosswalk	0	0	0	0	0	0	0	0	0	0	0	0	0	0	0	0	1	1
% Bicycles on Crosswalk	0.0%	0.0%	0.0%	0.0%	0.0%	0.0%	0.0%	0.0%	0.0%	0.0%	0.0%	0.0%	0.0%	0.0%	0.0%	0.0%	25.0%	50.0%

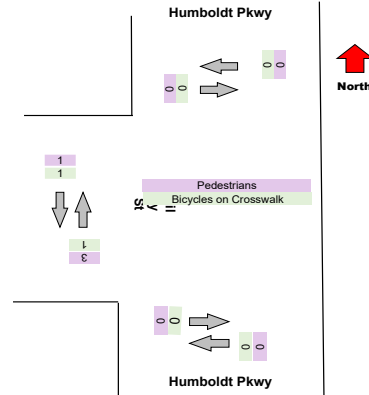
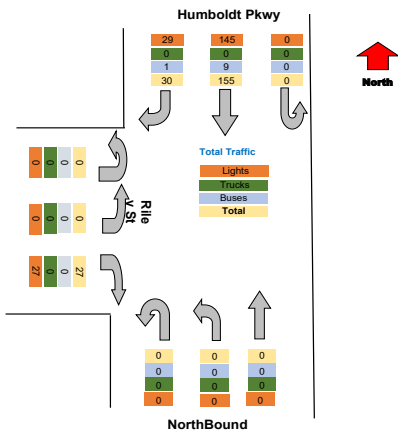

Intersection: Elm St Pine St  
 Location: Kennett Square, PA  
 Site: 01  
 Survey Date: Wednesday, 04-28-2021  
 GPS: 42.948550, -72.790034



<b>Total</b>
15
22
37
16
26
27
60
129
43
47
90
55
64
52
44
215
52
47
50
39
188
659
0.0%
0.0%
622
94.4%
0
0.0%
36
5.5%
0
0.0%
0.0%

Intersection: Elm St Pine St  
Location: Kennett Square, PA  
Site: 01  
Survey Date: Wednesday, 04-28-2021  
GPS: 42.948550, -72.790034



Total
27
60
43
47
177
0.738
167
94.4%
0
0.0%
10
5.6%
0
0.0%
0
0.0%

Intersection: Elm St Pine St  
Location: Kennett Square, PA  
Site: 01  
Survey Date: Wednesday, 04-28-2021  
GPS: 42.948550, -72.790034



Total
64
52
44
52
212
0.828
201
94.8%
0
0.0%
10
4.7%
0
0.0%
0
0.0%

Project	Labella
Project Code	Labella
Site Name	D
Legs and Movements	All Processed Legs & Movements
Bin Size	15 minutes
Survey Date	2021-10-26, Tuesday
Location	D
Latitude and Longitude	42.908145, -78.843950

	Start	End	PHF
Forced Peak AM	2021/10/26 07:30:00	2021/10/26 08:30:00	0.951
Forced Peak PM	2021/10/26 16:30:00	2021/10/26 17:30:00	0.892
AM Peak	2021/10/26 07:30:00	2021/10/26 08:30:00	0.951
PM Peak	2021/10/26 16:15:00	2021/10/26 17:15:00	0.914

Turning Movement Data

Leg Direction	Humboldt Pkwy Southbound						Humboldt Pkwy NorthBound						Kingsley St Eastbound															
	Right	Thru	U-Turn	App	Total	Peds	CW	Peds	CCW	Thru	Left	U-Turn	App	Total	Peds	CW	Peds	CCW	Right	Left	U-Turn	App	Total	Peds	CW	Peds	CCW	
Start Time	1	18	0	19	0	0	0	0	0	0	0	0	0	0	0	0	2	0	0	2	0	0	2	0	0	2	0	0
6:30:00 AM	1	18	0	19	0	0	0	0	0	0	0	0	0	0	0	0	2	0	0	2	0	0	2	0	0	2	0	0
6:45:00 AM	1	23	0	24	0	0	0	0	0	0	0	0	0	0	0	0	2	0	0	2	0	0	2	0	0	2	0	0
Hourly Total	2	41	0	43	0	0	0	0	0	0	0	0	0	0	0	0	4	0	0	4	0	0	4	0	0	4	0	0
7:00:00 AM	0	18	0	18	0	0	0	0	0	0	0	0	0	0	0	0	2	0	0	2	0	0	2	0	0	2	0	0
7:15:00 AM	2	15	0	17	0	0	0	0	0	0	0	0	0	0	0	0	0	0	0	0	0	0	0	0	0	0	0	0
7:30:00 AM	2	28	0	30	0	0	0	0	0	0	0	0	0	0	0	0	4	0	0	4	0	0	4	0	0	4	0	0
7:45:00 AM	2	31	0	33	0	0	0	0	0	0	0	0	0	0	0	0	3	0	0	3	0	0	3	0	0	3	0	0
Hourly Total	6	92	0	98	0	0	0	0	0	0	0	0	0	0	0	0	9	0	0	9	0	0	9	0	0	9	0	0
8:00:00 AM	1	28	0	29	0	1	0	0	0	1	0	0	0	0	0	0	2	0	0	2	0	0	2	0	0	2	0	0
8:15:00 AM	4	28	0	32	0	0	0	0	0	0	0	0	0	0	0	0	3	0	0	3	0	0	3	0	0	3	0	0
Hourly Total	5	56	0	61	0	1	0	0	0	1	0	0	0	0	0	0	5	0	0	5	0	0	5	0	0	5	0	0
4:00:00 PM	7	56	0	63	0	0	0	0	0	0	0	0	0	0	0	0	1	0	0	1	0	0	1	0	0	1	0	0
4:15:00 PM	0	50	0	50	0	0	0	0	0	0	0	0	0	0	0	0	5	0	0	5	0	0	5	0	0	5	0	0
4:30:00 PM	0	49	0	49	0	0	0	0	0	0	0	0	0	0	0	0	3	0	0	3	0	0	3	0	0	3	0	1
4:45:00 PM	3	47	0	50	0	0	0	0	0	0	0	0	0	0	0	0	3	0	0	3	0	0	3	0	0	3	0	0
Hourly Total	10	202	0	212	0	0	0	0	0	0	0	0	0	0	0	0	12	0	0	12	0	1	12	0	0	12	0	1
5:00:00 PM	1	39	0	40	0	0	0	0	0	0	0	0	0	0	0	0	1	0	0	1	0	1	1	0	0	1	0	1
5:15:00 PM	3	39	0	42	0	0	0	0	0	0	0	0	0	0	0	0	1	0	0	1	0	0	1	0	0	1	0	0
5:30:00 PM	6	38	0	44	0	0	0	0	0	0	0	0	0	0	0	0	4	0	0	4	0	0	4	0	0	4	0	0
5:45:00 PM	1	30	0	31	0	0	0	0	0	0	0	0	0	0	0	0	3	0	0	3	0	1	3	0	0	3	0	1
Hourly Total	11	146	0	157	0	0	0	0	0	0	0	0	0	0	0	0	9	0	0	9	0	2	9	0	0	9	0	2
Grand Total	34	537	0	571	0	1	0	0	0	1	0	0	0	0	0	0	39	0	0	39	0	3	39	0	0	39	0	3
% Approach	6.0%	94.0%	0.0%	0.0%	0.0%	0.0%	0.0%	0.0%	0.0%	0.0%	0.0%	0.0%	0.0%	0.0%	0.0%	0.0%	100.0%	0.0%	0.0%	0.0%	0.0%	0.0%	0.0%	0.0%	0.0%	0.0%	0.0%	0.0%
% Total	5.6%	87.9%	0.0%	93.5%	0.0%	0.0%	0.0%	0.0%	0.0%	0.2%	0.0%	0.0%	0.0%	0.0%	0.0%	0.0%	6.4%	0.0%	0.0%	6.4%	0.0%	0.0%	6.4%	0.0%	0.0%	6.4%	0.0%	0.0%
Lights	34	508	0	542	0	0	0	0	0	0	0	0	0	0	0	0	37	0	0	37	0	0	37	0	0	37	0	0
% Lights	100.0%	94.6%	0.0%	94.9%	0.0%	0.0%	0.0%	0.0%	0.0%	0.0%	0.0%	0.0%	0.0%	0.0%	0.0%	0.0%	94.9%	0.0%	0.0%	94.9%	0.0%	0.0%	94.9%	0.0%	0.0%	94.9%	0.0%	0.0%
Trucks	0	0	0	0	0	0	0	0	0	0	0	0	0	0	0	0	0	0	0	0	0	0	0	0	0	0	0	0
% Trucks	0.0%	0.0%	0.0%	0.0%	0.0%	0.0%	0.0%	0.0%	0.0%	0.0%	0.0%	0.0%	0.0%	0.0%	0.0%	0.0%	0.0%	0.0%	0.0%	0.0%	0.0%	0.0%	0.0%	0.0%	0.0%	0.0%	0.0%	0.0%
Buses	0	29	0	29	0	0	0	0	0	0	0	0	0	0	0	0	2	0	0	2	0	0	2	0	0	2	0	0
% Buses	0.0%	5.4%	0.0%	0.0%	0.0%	0.0%	0.0%	0.0%	0.0%	0.0%	0.0%	0.0%	0.0%	0.0%	0.0%	0.0%	5.1%	0.0%	0.0%	0.0%	0.0%	0.0%	0.0%	0.0%	0.0%	0.0%	0.0%	0.0%
Pedestrians	0	0	0	0	0	1	0	0	0	0	0	0	0	0	0	0	0	0	0	0	0	3	0	0	0	0	0	3
% Pedestrians	0.0%	0.0%	0.0%	0.0%	0.0%	100.0%	0.0%	0.0%	0.0%	0.0%	0.0%	0.0%	0.0%	0.0%	0.0%	0.0%	0.0%	0.0%	0.0%	0.0%	0.0%	100.0%	0.0%	0.0%	0.0%	0.0%	0.0%	100.0%
% Bicycles on Crosswalk	0.0%	0.0%	0.0%	0.0%	0.0%	0.0%	0.0%	0.0%	0.0%	0.0%	0.0%	0.0%	0.0%	0.0%	0.0%	0.0%	0.0%	0.0%	0.0%	0.0%	0.0%	0.0%	0.0%	0.0%	0.0%	0.0%	0.0%	0.0%

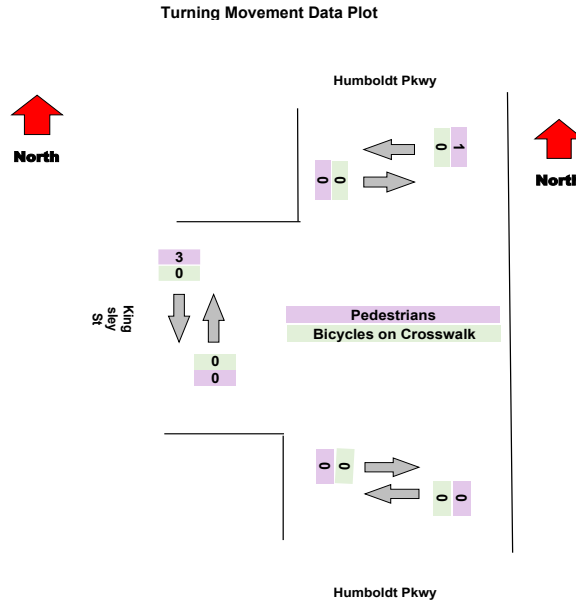
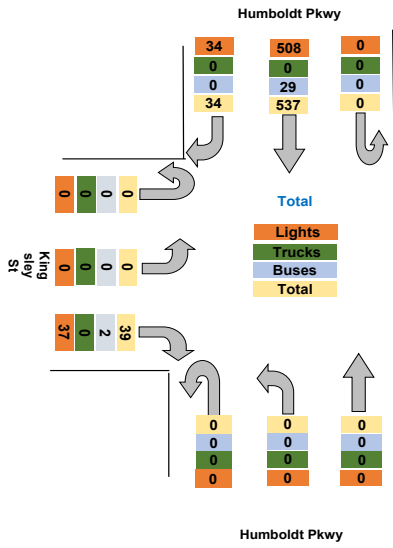



Turning Movement Peak Hour Data (AM)

7:30:00 AM

Leg Direction	Humboldt Pkwy Southbound						Humboldt Pkwy NorthBound						Kingsley St Eastbound					
	Right	Thru	U-Turn	App Total	Peds CW	Peds CCW	Thru	Left	U-Turn	App Total	Peds CW	Peds CCW	Right	Left	U-Turn	App Total	Peds CW	Peds CCW
7:30:00 AM	2	28	0	30	0	0	0	0	0	0	0	0	4	0	0	4	0	0
7:45:00 AM	2	31	0	33	0	0	0	0	0	0	0	0	3	0	0	3	0	0
8:00:00 AM	1	28	0	29	0	1	0	0	0	1	0	0	2	0	0	2	0	0
8:15:00 AM	4	28	0	32	0	0	0	0	0	0	0	0	3	0	0	3	0	0
<b>Grand Total</b>	9	115	0	124	0	1	0	0	0	1	0	0	12	0	0	12	0	0
% Approach	7.3%	92.7%	0.0%	0.0%	0.0%	0.0%	14.2%	0.0%	0.0%	0.0%	0.0%	0.0%	45.1%	41.7%	0.0%	0.0%	0.0%	0.0%
% Total	6.6%	83.9%	0.0%	90.5%	0.0%	0.0%	0.0%	0.0%	0.0%	0.7%	0.0%	0.0%	8.8%	0.0%	0.0%	8.8%	0.0%	0.0%
PHF	0.563	0.927	0.000	0.939	0.000	0.000	0.000	0.000	0.000	0.250	0.000	0.000	0.750	0.000	0.000	0.750	0.000	0.000
Lights	9	107	0	116	0	0	0	0	0	0	0	0	11	0	0	11	0	0
% Lights	100.0%	93.0%	0.0%	93.5%	0.0%	0.0%	0.0%	0.0%	0.0%	0.0%	0.0%	0.0%	91.7%	0.0%	0.0%	91.7%	0.0%	0.0%
Trucks	0	0	0	0	0	0	0	0	0	0	0	0	0	0	0	0	0	0
% Trucks	0.0%	0.0%	0.0%	0.0%	0.0%	0.0%	0.0%	0.0%	0.0%	0.0%	0.0%	0.0%	0.0%	0.0%	0.0%	0.0%	0.0%	0.0%
Buses	0	8	0	8	0	0	0	0	0	0	0	0	1	0	0	1	0	0
% Buses	0.0%	7.0%	0.0%	0.0%	0.0%	0.0%	0.0%	0.0%	0.0%	0.0%	0.0%	0.0%	8.3%	0.0%	0.0%	0.0%	0.0%	0.0%
Pedestrians	0	0	0	0	0	1	0	0	0	0	0	0	0	0	0	0	0	0
% Pedestrians	0.0%	0.0%	0.0%	0.0%	0.0%	100.0%	0.0%	0.0%	0.0%	0.0%	0.0%	0.0%	0.0%	0.0%	0.0%	0.0%	0.0%	0.0%
Bicycles on Crosswalk	0	0	0	0	0	0	0	0	0	0	0	0	0	0	0	0	0	0
% Bicycles on Crosswalk	0.0%	0.0%	0.0%	0.0%	0.0%	0.0%	0.0%	0.0%	0.0%	0.0%	0.0%	0.0%	0.0%	0.0%	0.0%	0.0%	0.0%	0.0%

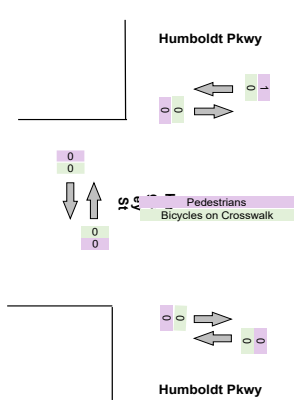
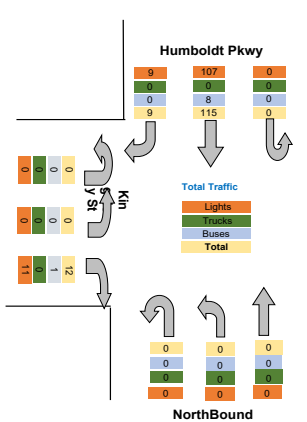

Turning Movement Peak Hour Data (PM)

4:15:00 PM

Leg Direction	Humboldt Pkwy Southbound						Humboldt Pkwy NorthBound						Kingsley St Eastbound					
	Right	Thru	U-Turn	App Total	Peds CW	Peds CCW	Thru	Left	U-Turn	App Total	Peds CW	Peds CCW	Right	Left	U-Turn	App Total	Peds CW	Peds CCW
4:15:00 PM	0	50	0	50	0	0	0	0	0	0	0	5	0	0	5	0	0	0
4:30:00 PM	0	49	0	49	0	0	0	0	0	0	0	3	0	0	3	0	0	1
4:45:00 PM	3	47	0	50	0	0	0	0	0	0	0	3	0	0	3	0	0	0
5:00:00 PM	1	39	0	40	0	0	0	0	0	0	0	1	0	0	1	0	0	1
<b>Grand Total</b>	<b>4</b>	<b>185</b>	<b>0</b>	<b>189</b>	<b>0</b>	<b>0</b>	<b>0</b>	<b>0</b>	<b>0</b>	<b>0</b>	<b>0</b>	<b>12</b>	<b>0</b>	<b>0</b>	<b>12</b>	<b>0</b>	<b>0</b>	<b>2</b>
% Approach	2.1%	97.9%	0.0%	0.0%	0.0%	0.0%	14.2%	0.0%	0.0%	0.0%	0.0%	45.1%	41.7%	0.0%	0.0%	0.0%	0.0%	0.0%
% Total	2.0%	92.0%	0.0%	94.0%	0.0%	0.0%	0.0%	0.0%	0.0%	0.0%	0.0%	6.0%	0.0%	0.0%	6.0%	0.0%	0.0%	0.0%
PHF	0.333	0.925	0.000	0.945	0.000	0.000	0.000	0.000	0.000	0.000	0.000	0.600	0.000	0.000	0.600	0.000	0.000	0.000
Lights	4	176	0	180	0	0	0	0	0	0	0	11	0	0	11	0	0	0
% Lights	100.0%	95.1%	0.0%	95.2%	0.0%	0.0%	0.0%	0.0%	0.0%	0.0%	0.0%	91.7%	0.0%	0.0%	91.7%	0.0%	0.0%	0.0%
Trucks	0	0	0	0	0	0	0	0	0	0	0	0	0	0	0	0	0	0
% Trucks	0.0%	0.0%	0.0%	0.0%	0.0%	0.0%	0.0%	0.0%	0.0%	0.0%	0.0%	0.0%	0.0%	0.0%	0.0%	0.0%	0.0%	0.0%
Buses	0	9	0	9	0	0	0	0	0	0	0	1	0	0	1	0	0	0
% Buses	0.0%	4.9%	0.0%	0.0%	0.0%	0.0%	0.0%	0.0%	0.0%	0.0%	0.0%	8.3%	0.0%	0.0%	0.0%	0.0%	0.0%	0.0%
Pedestrians	0	0	0	0	0	0	0	0	0	0	0	0	0	0	0	0	0	2
% Pedestrians	0.0%	0.0%	0.0%	0.0%	0.0%	0.0%	0.0%	0.0%	0.0%	0.0%	0.0%	0.0%	0.0%	0.0%	0.0%	0.0%	0.0%	100.0%
Bicycles on Crosswalk	0	0	0	0	0	0	0	0	0	0	0	0	0	0	0	0	0	0
% Bicycles on Crosswalk	0.0%	0.0%	0.0%	0.0%	0.0%	0.0%	0.0%	0.0%	0.0%	0.0%	0.0%	0.0%	0.0%	0.0%	0.0%	0.0%	0.0%	0.0%

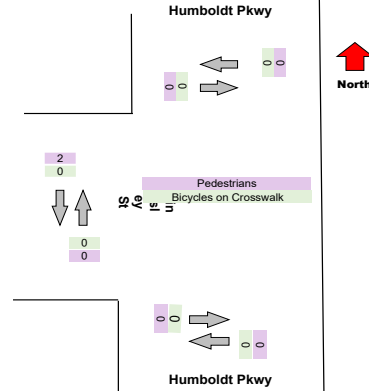
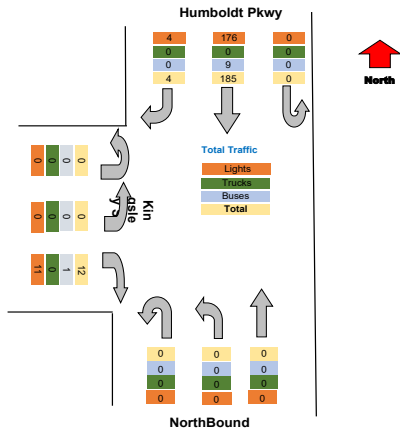

Intersection: Elm St Pine St  
 Location: Kennett Square, PA  
 Site: 01  
 Survey Date: Wednesday, 04-28-2021  
 GPS: 42.948550, -72.790034



<b>Total</b>
21
26
47
20
17
34
36
107
32
35
67
64
55
52
53
224
41
43
48
34
166
611
0.0%
0.0%
579
94.8%
0
0.0%
31
5.1%
0
0.0%
0.0%

Intersection: Elm St Pine St  
Location: Kennett Square, PA  
Site: 01  
Survey Date: Wednesday, 04-28-2021  
GPS: 42.948550, -72.790034



Total
34
36
32
35
137
0.951
127
92.7%
0
0.0%
9
6.6%
0
0.0%
0
0.0%

Intersection: Elm St Pine St  
Location: Kennett Square, PA  
Site: 01  
Survey Date: Wednesday, 04-28-2021  
GPS: 42.948550, -72.790034



Total
55
52
53
41
201
0.914
191
95.0%
0
0.0%
10
5.0%
0
0.0%
0
0.0%

Project	Labella
Project Code	Labella
Site Name	D
Legs and Movements	All Processed Legs & Movements
Bin Size	15 minutes
Survey Date	2021-10-27, Wednesday
Location	D
Latitude and Longitude	42.908145, -78.843950

	Start	End	PHF
Forced Peak AM	2021/10/27 07:30:00	2021/10/27 08:30:00	0.815
Forced Peak PM	2021/10/27 16:30:00	2021/10/27 17:30:00	0.826
AM Peak	2021/10/27 07:30:00	2021/10/27 08:30:00	0.815
PM Peak	2021/10/27 16:15:00	2021/10/27 17:15:00	0.871

Turning Movement Data

Leg Direction	Humboldt Pkwy Southbound						Humboldt Pkwy Northbound						Kingsley St Eastbound											
	Right	Thru	U-Turn	App Total	Peds	CW	Peds	CCW	Thru	Left	U-Turn	App Total	Peds	CW	Peds	CCW	Right	Left	U-Turn	App Total	Peds	CW	Peds	CCW
Start Time	1	9	0	10	0	0	0	0	0	0	0	0	0	0	0	0	1	0	0	1	0	0	0	0
6:30:00 AM	1	9	0	10	0	0	0	0	0	0	0	0	0	0	0	0	1	0	0	1	0	0	0	0
6:45:00 AM	2	22	0	24	0	0	0	0	0	0	0	0	0	0	0	0	1	0	0	1	0	0	0	0
Hourly Total	3	31	0	34	0	0	0	0	0	0	0	0	0	0	0	0	2	0	0	2	0	0	0	0
7:00:00 AM	0	18	0	18	0	2	0	0	0	0	2	0	0	0	0	0	0	0	0	0	0	0	1	1
7:15:00 AM	1	18	0	19	0	0	0	0	0	0	0	0	0	0	0	0	3	0	0	3	0	0	0	0
7:30:00 AM	0	14	0	14	0	0	0	0	0	0	0	0	0	0	0	0	0	0	0	0	0	0	0	0
7:45:00 AM	0	40	0	40	0	0	0	0	0	0	0	0	0	0	0	0	2	0	0	2	1	0	0	0
Hourly Total	1	90	0	91	0	2	0	0	0	0	2	0	0	0	0	0	5	0	0	5	1	1	1	1
8:00:00 AM	2	37	0	39	0	0	0	0	0	0	0	0	0	0	0	0	0	0	0	0	1	0	0	0
8:15:00 AM	2	34	0	36	0	0	0	0	0	0	0	0	0	0	0	0	6	0	0	6	0	0	0	0
Hourly Total	4	71	0	75	0	0	0	0	0	0	0	0	0	0	0	0	6	0	0	6	1	0	0	0
4:00:00 PM	3	46	0	49	0	0	0	0	0	0	0	0	0	0	0	0	5	0	0	5	0	0	0	0
4:15:00 PM	3	47	0	50	0	0	0	0	0	0	0	0	0	0	0	0	5	0	0	5	0	0	0	0
4:30:00 PM	3	49	0	52	0	0	0	0	0	0	0	0	0	0	0	0	4	0	0	4	0	0	0	0
4:45:00 PM	0	36	0	36	0	0	0	0	0	0	0	0	0	0	0	0	2	0	0	2	1	1	1	1
Hourly Total	9	178	0	187	0	0	0	0	0	0	0	0	0	0	0	0	16	0	0	16	1	1	1	1
5:00:00 PM	2	37	0	39	0	0	0	0	0	0	0	0	0	0	0	0	7	0	0	7	0	0	0	0
5:15:00 PM	5	35	0	40	0	0	0	0	0	0	0	0	0	0	0	0	5	0	0	5	0	1	1	1
5:30:00 PM	3	42	0	45	0	0	0	0	0	0	0	0	0	0	0	0	1	0	0	1	2	0	0	0
5:45:00 PM	0	31	0	31	0	0	0	0	0	0	0	0	0	0	0	0	1	0	0	1	1	2	2	2
Hourly Total	10	145	0	155	0	0	0	0	0	0	0	0	0	0	0	0	14	0	0	14	3	3	3	3
Grand Total	27	515	0	542	0	2	0	0	0	0	2	0	0	0	0	0	43	0	0	43	6	5	5	5
% Approach	5.0%	95.0%	0.0%	0.0%	0.0%	0.0%	0.0%	0.0%	0.0%	0.0%	0.0%	0.0%	0.0%	0.0%	0.0%	0.0%	100.0%	0.0%	0.0%	0.0%	0.0%	0.0%	0.0%	0.0%
% Total	4.6%	87.7%	0.0%	92.3%	0.0%	0.0%	0.0%	0.0%	0.0%	0.0%	0.3%	0.0%	0.0%	0.0%	0.0%	0.0%	7.3%	0.0%	0.0%	7.3%	0.0%	0.0%	0.0%	0.0%
Lights	27	483	0	510	0	0	0	0	0	0	0	0	0	0	0	0	40	0	0	40	0	0	0	0
% Lights	100.0%	93.8%	0.0%	94.1%	0.0%	0.0%	0.0%	0.0%	0.0%	0.0%	0.0%	0.0%	0.0%	0.0%	0.0%	0.0%	93.0%	0.0%	0.0%	93.0%	0.0%	0.0%	0.0%	0.0%
Trucks	0	0	0	0	0	0	0	0	0	0	0	0	0	0	0	0	0	0	0	0	0	0	0	0
% Trucks	0.0%	0.0%	0.0%	0.0%	0.0%	0.0%	0.0%	0.0%	0.0%	0.0%	0.0%	0.0%	0.0%	0.0%	0.0%	0.0%	0.0%	0.0%	0.0%	0.0%	0.0%	0.0%	0.0%	0.0%
Buses	0	30	0	30	0	0	0	0	0	0	0	0	0	0	0	0	3	0	0	3	0	0	0	0
% Buses	0.0%	5.8%	0.0%	0.0%	0.0%	0.0%	0.0%	0.0%	0.0%	0.0%	0.0%	0.0%	0.0%	0.0%	0.0%	0.0%	7.0%	0.0%	0.0%	0.0%	0.0%	0.0%	0.0%	0.0%
Pedestrians	0	0	0	0	0	2	0	0	0	0	0	0	0	0	0	0	0	0	0	0	5	5	5	5
% Pedestrians	0.0%	0.0%	0.0%	0.0%	0.0%	100.0%	0.0%	0.0%	0.0%	0.0%	0.0%	0.0%	0.0%	0.0%	0.0%	0.0%	0.0%	0.0%	0.0%	0.0%	83.3%	100.0%	100.0%	100.0%
% Bicycles on Crosswalk	0.0%	0.0%	0.0%	0.0%	0.0%	0.0%	0.0%	0.0%	0.0%	0.0%	0.0%	0.0%	0.0%	0.0%	0.0%	0.0%	0.0%	0.0%	0.0%	0.0%	16.7%	0.0%	0.0%	0.0%

Turning Movement Data Plot

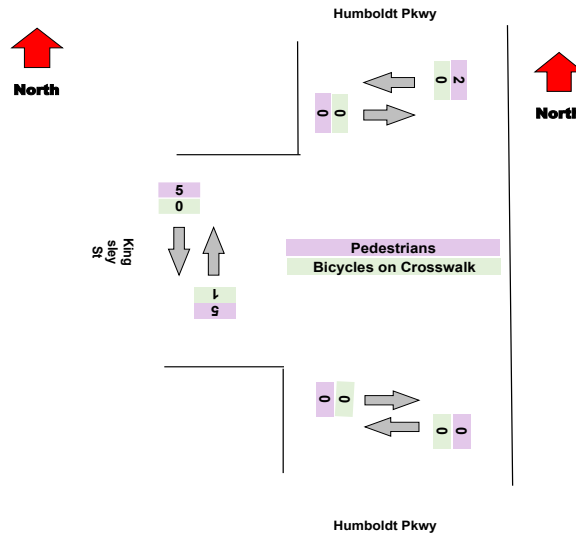
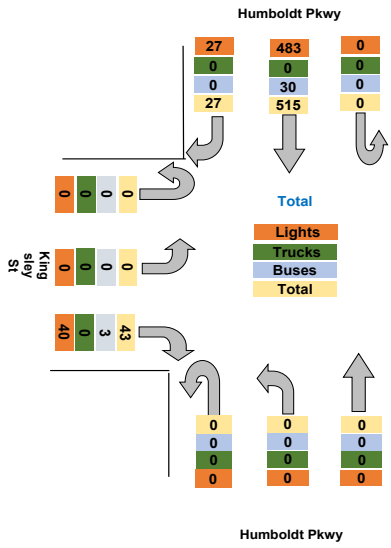

Turning Movement Peak Hour Data (AM)

7:30:00 AM

Leg Direction	Humboldt Pkwy Southbound						Humboldt Pkwy NorthBound						Kingsley St Eastbound					
	Right	Thru	U-Turn	App Total	Peds CW	Peds CCW	Thru	Left	U-Turn	App Total	Peds CW	Peds CCW	Right	Left	U-Turn	App Total	Peds CW	Peds CCW
7:30:00 AM	0	14	0	14	0	0	0	0	0	0	0	0	0	0	0	0	0	0
7:45:00 AM	0	40	0	40	0	0	0	0	0	0	0	0	2	0	0	2	1	0
8:00:00 AM	2	37	0	39	0	0	0	0	0	0	0	0	0	0	0	0	1	0
8:15:00 AM	2	34	0	36	0	0	0	0	0	0	0	0	6	0	0	6	0	0
<b>Grand Total</b>	<b>4</b>	<b>125</b>	<b>0</b>	<b>129</b>	<b>0</b>	<b>0</b>	<b>0</b>	<b>0</b>	<b>0</b>	<b>0</b>	<b>0</b>	<b>0</b>	<b>8</b>	<b>0</b>	<b>0</b>	<b>8</b>	<b>2</b>	<b>0</b>
% Approach	3.1%	96.9%	0.0%	0.0%	0.0%	0.0%	14.2%	0.0%	0.0%	0.0%	0.0%	0.0%	45.1%	41.7%	0.0%	0.0%	0.0%	0.0%
% Total	2.9%	91.2%	0.0%	94.2%	0.0%	0.0%	0.0%	0.0%	0.0%	0.0%	0.0%	0.0%	5.8%	0.0%	0.0%	5.8%	0.0%	0.0%
PHF	0.500	0.781	0.000	0.806	0.000	0.000	0.000	0.000	0.000	0.000	0.000	0.000	0.333	0.000	0.000	0.333	0.000	0.000
Lights	4	118	0	122	0	0	0	0	0	0	0	0	6	0	0	6	0	0
% Lights	100.0%	94.4%	0.0%	94.6%	0.0%	0.0%	0.0%	0.0%	0.0%	0.0%	0.0%	0.0%	75.0%	0.0%	0.0%	75.0%	0.0%	0.0%
Trucks	0	0	0	0	0	0	0	0	0	0	0	0	0	0	0	0	0	0
% Trucks	0.0%	0.0%	0.0%	0.0%	0.0%	0.0%	0.0%	0.0%	0.0%	0.0%	0.0%	0.0%	0.0%	0.0%	0.0%	0.0%	0.0%	0.0%
Buses	0	7	0	7	0	0	0	0	0	0	0	0	2	0	0	2	0	0
% Buses	0.0%	5.6%	0.0%	0.0%	0.0%	0.0%	0.0%	0.0%	0.0%	0.0%	0.0%	0.0%	25.0%	0.0%	0.0%	0.0%	0.0%	0.0%
Pedestrians	0	0	0	0	0	0	0	0	0	0	0	0	0	0	0	0	2	0
% Pedestrians	0.0%	0.0%	0.0%	0.0%	0.0%	0.0%	0.0%	0.0%	0.0%	0.0%	0.0%	0.0%	0.0%	0.0%	0.0%	0.0%	100.0%	0.0%
Bicycles on Crosswalk	0	0	0	0	0	0	0	0	0	0	0	0	0	0	0	0	0	0
% Bicycles on Crosswalk	0.0%	0.0%	0.0%	0.0%	0.0%	0.0%	0.0%	0.0%	0.0%	0.0%	0.0%	0.0%	0.0%	0.0%	0.0%	0.0%	0.0%	0.0%

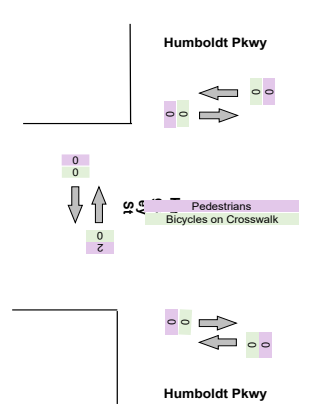
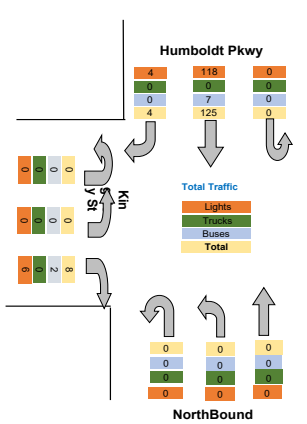



Turning Movement Peak Hour Data (PM)

4:15:00 PM

Leg Direction	Humboldt Pkwy Southbound						Humboldt Pkwy NorthBound						Kingsley St Eastbound					
	Right	Thru	U-Turn	App Total	Peds CW	Peds CCW	Thru	Left	U-Turn	App Total	Peds CW	Peds CCW	Right	Left	U-Turn	App Total	Peds CW	Peds CCW
4:15:00 PM	3	47	0	50	0	0	0	0	0	0	0	0	5	0	0	5	0	0
4:30:00 PM	3	49	0	52	0	0	0	0	0	0	0	0	4	0	0	4	0	0
4:45:00 PM	0	36	0	36	0	0	0	0	0	0	0	0	2	0	0	2	1	1
5:00:00 PM	2	37	0	39	0	0	0	0	0	0	0	0	7	0	0	7	0	0
<b>Grand Total</b>	<b>8</b>	<b>169</b>	<b>0</b>	<b>177</b>	<b>0</b>	<b>0</b>	<b>0</b>	<b>0</b>	<b>0</b>	<b>0</b>	<b>0</b>	<b>0</b>	<b>18</b>	<b>0</b>	<b>0</b>	<b>18</b>	<b>1</b>	<b>1</b>
% Approach	4.5%	95.5%	0.0%	0.0%	0.0%	0.0%	14.2%	0.0%	0.0%	0.0%	0.0%	0.0%	45.1%	41.7%	0.0%	0.0%	0.0%	0.0%
% Total	4.1%	86.7%	0.0%	90.8%	0.0%	0.0%	0.0%	0.0%	0.0%	0.0%	0.0%	0.0%	9.2%	0.0%	0.0%	9.2%	0.0%	0.0%
PHF	0.667	0.862	0.000	0.851	0.000	0.000	0.000	0.000	0.000	0.000	0.000	0.000	0.643	0.000	0.000	0.643	0.000	0.000
Lights	8	158	0	166	0	0	0	0	0	0	0	0	17	0	0	17	0	0
% Lights	100.0%	93.5%	0.0%	93.8%	0.0%	0.0%	0.0%	0.0%	0.0%	0.0%	0.0%	0.0%	94.4%	0.0%	0.0%	94.4%	0.0%	0.0%
Trucks	0	0	0	0	0	0	0	0	0	0	0	0	0	0	0	0	0	0
% Trucks	0.0%	0.0%	0.0%	0.0%	0.0%	0.0%	0.0%	0.0%	0.0%	0.0%	0.0%	0.0%	0.0%	0.0%	0.0%	0.0%	0.0%	0.0%
Buses	0	10	0	10	0	0	0	0	0	0	0	0	0	0	0	1	0	0
% Buses	0.0%	5.9%	0.0%	0.0%	0.0%	0.0%	0.0%	0.0%	0.0%	0.0%	0.0%	0.0%	5.6%	0.0%	0.0%	0.0%	0.0%	0.0%
Pedestrians	0	0	0	0	0	0	0	0	0	0	0	0	0	0	0	0	0	1
% Pedestrians	0.0%	0.0%	0.0%	0.0%	0.0%	0.0%	0.0%	0.0%	0.0%	0.0%	0.0%	0.0%	0.0%	0.0%	0.0%	0.0%	0.0%	100.0%
Bicycles on Crosswalk	0	0	0	0	0	0	0	0	0	0	0	0	0	0	0	0	1	0
% Bicycles on Crosswalk	0.0%	0.0%	0.0%	0.0%	0.0%	0.0%	0.0%	0.0%	0.0%	0.0%	0.0%	0.0%	0.0%	0.0%	0.0%	0.0%	100.0%	0.0%

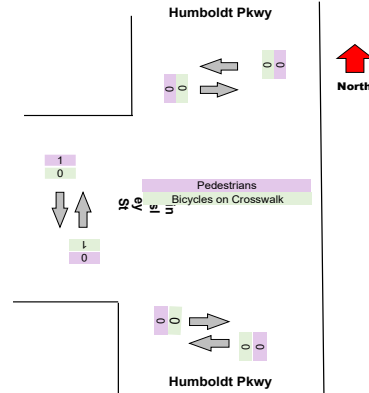
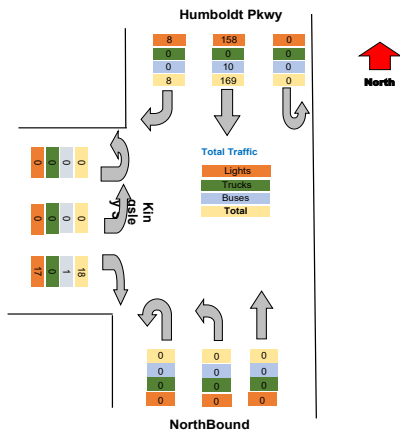

Intersection: Elm St Pine St  
 Location: Kennett Square, PA  
 Site: 01  
 Survey Date: Wednesday, 04-28-2021  
 GPS: 42.948550, -72.790034



<b>Total</b>
11
25
36
20
22
14
42
98
39
42
81
54
55
56
38
203
46
45
46
32
169
587
0.0%
0.0%
550
93.7%
0
0.0%
33
5.6%
0
0.0%
0.0%

Intersection: Elm St Pine St  
Location: Kennett Square, PA  
Site: 01  
Survey Date: Wednesday, 04-28-2021  
GPS: 42.948550, -72.790034



Total
14
42
39
42
137
0.815
128
93.4%
0
0.0%
9
6.6%
0
0.0%
0
0.0%

Intersection: Elm St Pine St  
Location: Kennett Square, PA  
Site: 01  
Survey Date: Wednesday, 04-28-2021  
GPS: 42.948550, -72.790034



Total
55
56
38
46
196
0.871
183
93.8%
0
0.0%
11
5.6%
0
0.0%
0
0.0%

Intersection: Elm St Pine St  
 Location: Kennett Square, PA  
 Site: 01  
 Survey Date: Wednesday, 04-28-2021  
 GPS: 42.948550, -72.790034



TSTData.com

Project	Labella
Project Code	Labella
Site Name	D
Legs and Movements	All Processed Legs & Movement
Bin Size	15 minutes
Survey Date	2021-10-28, Thursday
Location	D
Latitude and Longitude	42.908145, -78.843950

	Start	End	PHF
Forced Peak AM	2021/10/28 07:30:00	2021/10/28 08:30:00	0.745
Forced Peak PM	2021/10/28 16:30:00	2021/10/28 17:30:00	0.88
AM Peak	2021/10/28 07:30:00	2021/10/28 08:30:00	0.745
PM Peak	2021/10/28 16:15:00	2021/10/28 17:15:00	0.848

Turning Movement Data

Leg Direction	Humboldt Pkwy Southbound						Humboldt Pkwy Northbound						Kingsley St Eastbound						Total
	Right	Thru	U-Turn	App Total	Peds CW	Peds CCW	Thru	Left	U-Turn	App Total	Peds CW	Peds CCW	Right	Left	U-Turn	App Total	Peds CW	Peds CCW	
6:30:00 AM	0	11	0	11	0	0	0	0	0	0	0	0	1	0	0	1	0	0	12
6:45:00 AM	1	16	0	17	0	0	0	0	0	0	0	0	2	0	0	2	0	0	19
<b>Hourly Total</b>	<b>1</b>	<b>27</b>	<b>0</b>	<b>28</b>	<b>0</b>	<b>0</b>	<b>0</b>	<b>0</b>	<b>0</b>	<b>0</b>	<b>0</b>	<b>0</b>	<b>3</b>	<b>0</b>	<b>0</b>	<b>3</b>	<b>0</b>	<b>0</b>	<b>31</b>
7:00:00 AM	0	16	0	16	0	0	0	0	0	0	0	0	1	0	0	1	0	0	17
7:15:00 AM	0	18	0	18	0	0	0	0	0	0	0	0	1	0	0	1	0	0	19
7:30:00 AM	3	19	0	22	0	0	0	0	0	0	0	0	1	0	0	1	0	0	23
7:45:00 AM	0	52	0	52	0	0	0	0	0	0	0	0	1	0	0	1	0	0	53
<b>Hourly Total</b>	<b>3</b>	<b>105</b>	<b>0</b>	<b>108</b>	<b>0</b>	<b>0</b>	<b>0</b>	<b>0</b>	<b>0</b>	<b>0</b>	<b>0</b>	<b>0</b>	<b>4</b>	<b>0</b>	<b>0</b>	<b>4</b>	<b>0</b>	<b>1</b>	<b>112</b>
8:00:00 AM	0	35	0	35	0	0	0	0	0	0	0	0	1	0	0	1	0	0	36
8:15:00 AM	2	41	0	43	0	0	0	0	0	0	0	0	3	0	0	3	0	0	46
<b>Hourly Total</b>	<b>2</b>	<b>76</b>	<b>0</b>	<b>78</b>	<b>0</b>	<b>0</b>	<b>0</b>	<b>0</b>	<b>0</b>	<b>0</b>	<b>0</b>	<b>0</b>	<b>4</b>	<b>0</b>	<b>0</b>	<b>4</b>	<b>0</b>	<b>0</b>	<b>82</b>
4:00:00 PM	8	44	0	52	0	0	0	0	0	0	0	0	1	0	0	1	0	0	53
4:15:00 PM	3	52	0	55	0	0	0	0	0	0	0	0	1	0	0	1	0	0	56
4:30:00 PM	1	43	0	44	0	0	0	0	0	0	0	0	3	0	0	3	1	0	47
4:45:00 PM	2	33	0	35	0	0	0	0	0	0	0	0	2	0	0	2	0	0	37
<b>Hourly Total</b>	<b>14</b>	<b>172</b>	<b>0</b>	<b>186</b>	<b>0</b>	<b>0</b>	<b>0</b>	<b>0</b>	<b>0</b>	<b>0</b>	<b>0</b>	<b>0</b>	<b>7</b>	<b>0</b>	<b>0</b>	<b>7</b>	<b>1</b>	<b>2</b>	<b>193</b>
5:00:00 PM	4	44	0	48	0	0	0	0	0	0	0	0	2	0	0	2	1	2	50
5:15:00 PM	0	39	0	39	0	0	0	0	0	0	0	0	3	0	0	3	0	0	42
5:30:00 PM	3	39	0	42	0	0	0	0	0	0	0	0	2	0	0	2	2	1	44
5:45:00 PM	3	34	0	37	0	0	0	0	0	0	0	0	2	0	0	2	0	0	39
<b>Hourly Total</b>	<b>10</b>	<b>156</b>	<b>0</b>	<b>166</b>	<b>0</b>	<b>0</b>	<b>0</b>	<b>0</b>	<b>0</b>	<b>0</b>	<b>0</b>	<b>0</b>	<b>9</b>	<b>0</b>	<b>0</b>	<b>9</b>	<b>3</b>	<b>3</b>	<b>175</b>
<b>Grand Total</b>	<b>30</b>	<b>536</b>	<b>0</b>	<b>566</b>	<b>0</b>	<b>0</b>	<b>0</b>	<b>0</b>	<b>0</b>	<b>0</b>	<b>0</b>	<b>0</b>	<b>27</b>	<b>0</b>	<b>0</b>	<b>27</b>	<b>4</b>	<b>5</b>	<b>593</b>
% Approach	5.3%	94.7%	0.0%	0.0%	0.0%	0.0%	0.0%	0.0%	0.0%	0.0%	0.0%	0.0%	###	0.0%	0.0%	0.0%	0.0%	0.0%	0.0%
% Total	5.1%	90.4%	0.0%	95.4%	0.0%	0.0%	0.0%	0.0%	0.0%	0.0%	0.0%	0.0%	4.6%	0.0%	0.0%	4.6%	0.0%	0.0%	0.0%
Lights	29	504	0	533	0	0	0	0	0	0	0	0	25	0	0	25	0	0	558
% Lights	96.7%	94.0%	0.0%	94.2%	0.0%	0.0%	0.0%	0.0%	0.0%	0.0%	0.0%	0.0%	92.6%	0.0%	0.0%	92.6%	0.0%	0.0%	94.1%
Trucks	0	0	0	0	0	0	0	0	0	0	0	0	0	0	0	0	0	0	0
% Trucks	0.0%	0.0%	0.0%	0.0%	0.0%	0.0%	0.0%	0.0%	0.0%	0.0%	0.0%	0.0%	0.0%	0.0%	0.0%	0.0%	0.0%	0.0%	0.0%
Buses	1	31	0	32	0	0	0	0	0	0	0	0	2	0	0	2	0	0	34
% Buses	3.3%	5.8%	0.0%	0.0%	0.0%	0.0%	0.0%	0.0%	0.0%	0.0%	0.0%	0.0%	7.4%	0.0%	0.0%	0.0%	0.0%	0.0%	5.7%
Pedestrians	0	0	0	0	0	0	0	0	0	0	0	0	0	0	0	0	1	5	0
% Pedestrians	0.0%	0.0%	0.0%	0.0%	0.0%	0.0%	0.0%	0.0%	0.0%	0.0%	0.0%	0.0%	0.0%	0.0%	0.0%	0.0%	25.0%	83.3%	0.0%
% Bicycles on Crosswalk	0.0%	0.0%	0.0%	0.0%	0.0%	0.0%	0.0%	0.0%	0.0%	0.0%	0.0%	0.0%	0.0%	0.0%	0.0%	0.0%	75.0%	16.7%	0.0%

Turning Movement Data Plot

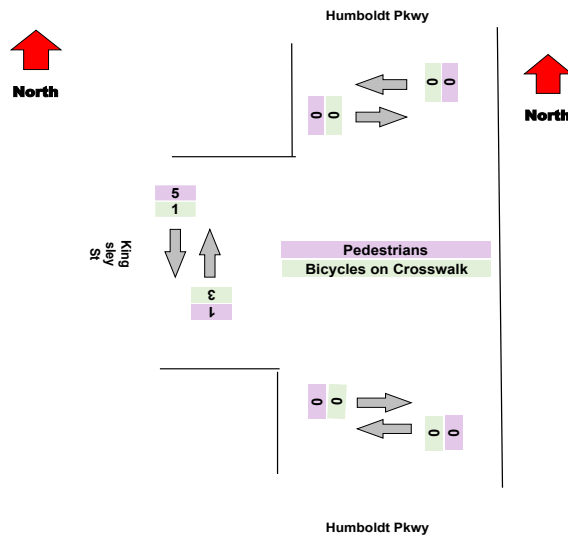
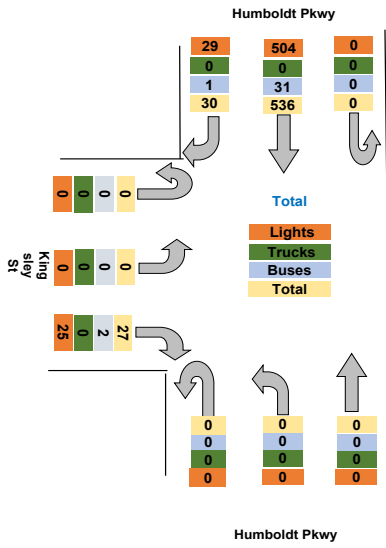

Turning Movement Peak Hour Data (AM)

7:30:00 AM

Leg Direction	Humboldt Pkwy Southbound						Humboldt Pkwy NorthBound						Kingsley St Eastbound						Total
	Right	Thru	U-Turn	App Total	Peds CW	Peds CCW	Thru	Left	U-Turn	App Total	Peds CW	Peds CCW	Right	Left	U-Turn	App Total	Peds CW	Peds CCW	
7:30:00 AM	3	19	0	22	0	0	0	0	0	0	0	0	1	0	0	1	0	0	23
7:45:00 AM	0	52	0	52	0	0	0	0	0	0	0	0	1	0	0	1	0	0	53
8:00:00 AM	0	35	0	35	0	0	0	0	0	0	0	0	1	0	0	1	0	0	36
8:15:00 AM	2	41	0	43	0	0	0	0	0	0	0	0	3	0	0	3	0	0	46
<b>Grand Total</b>	<b>5</b>	<b>147</b>	<b>0</b>	<b>152</b>	<b>0</b>	<b>0</b>	<b>0</b>	<b>0</b>	<b>0</b>	<b>0</b>	<b>0</b>	<b>0</b>	<b>6</b>	<b>0</b>	<b>0</b>	<b>6</b>	<b>0</b>	<b>0</b>	<b>158</b>
% Approach	3.3%	96.7%	0.0%	0.0%	0.0%	0.0%	14.2%	0.0%	0.0%	0.0%	0.0%	0.0%	45.1%	41.7%	0.0%	0.0%	0.0%	0.0%	0.0%
% Total	3.2%	93.0%	0.0%	96.2%	0.0%	0.0%	0.0%	0.0%	0.0%	0.0%	0.0%	0.0%	3.8%	0.0%	0.0%	3.8%	0.0%	0.0%	0.0%
PHF	0.417	0.707	0.000	0.731	0.000	0.000	0.000	0.000	0.000	0.000	0.000	0.000	0.500	0.000	0.000	0.500	0.000	0.000	0.745
Lights	5	137	0	142	0	0	0	0	0	0	0	0	5	0	0	5	0	0	147
% Lights	###	93.2%	0.0%	93.4%	0.0%	0.0%	0.0%	0.0%	0.0%	0.0%	0.0%	0.0%	83.3%	0.0%	0.0%	83.3%	0.0%	0.0%	93.0%
Trucks	0	0	0	0	0	0	0	0	0	0	0	0	0	0	0	0	0	0	0
% Trucks	0.0%	0.0%	0.0%	0.0%	0.0%	0.0%	0.0%	0.0%	0.0%	0.0%	0.0%	0.0%	0.0%	0.0%	0.0%	0.0%	0.0%	0.0%	0.0%
Buses	0	10	0	10	0	0	0	0	0	0	0	0	1	0	0	1	0	0	11
% Buses	0.0%	6.8%	0.0%	6.6%	0.0%	0.0%	0.0%	0.0%	0.0%	0.0%	0.0%	0.0%	16.7%	0.0%	0.0%	16.7%	0.0%	0.0%	7.0%
Pedestrians	0	0	0	0	0	0	0	0	0	0	0	0	0	0	0	0	0	0	0
% Pedestrians	0.0%	0.0%	0.0%	0.0%	0.0%	0.0%	0.0%	0.0%	0.0%	0.0%	0.0%	0.0%	0.0%	0.0%	0.0%	0.0%	0.0%	0.0%	0.0%
Bicycles on Crosswalk	0	0	0	0	0	0	0	0	0	0	0	0	0	0	0	0	0	0	0
% Bicycles on Crosswalk	0.0%	0.0%	0.0%	0.0%	0.0%	0.0%	0.0%	0.0%	0.0%	0.0%	0.0%	0.0%	0.0%	0.0%	0.0%	0.0%	0.0%	0.0%	0.0%

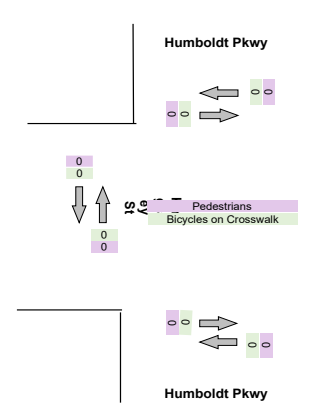
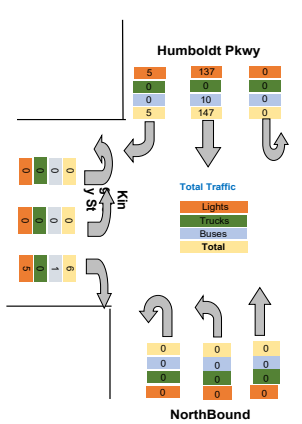

Turning Movement Peak Hour Data (PM)

4:15:00 PM

Leg Direction	Humboldt Pkwy Southbound						Humboldt Pkwy NorthBound						Kingsley St Eastbound						Total
	Right	Thru	U-Turn	App Total	Peds CW	Peds CCW	Thru	Left	U-Turn	App Total	Peds CW	Peds CCW	Right	Left	U-Turn	App Total	Peds CW	Peds CCW	
4:15:00 PM	3	52	0	55	0	0	0	0	0	0	0	0	1	0	0	1	0	0	56
4:30:00 PM	1	43	0	44	0	0	0	0	0	0	0	0	3	0	0	3	1	0	47
4:45:00 PM	2	33	0	35	0	0	0	0	0	0	0	0	2	0	0	2	0	0	37
5:00:00 PM	4	44	0	48	0	0	0	0	0	0	0	0	2	0	0	2	1	2	50
<b>Grand Total</b>	10	172	0	182	0	0	0	0	0	0	0	0	8	0	0	8	2	2	190
% Approach	5.5%	94.5%	0.0%	0.0%	0.0%	0.0%	14.2%	0.0%	0.0%	0.0%	0.0%	0.0%	45.1%	41.7%	0.0%	0.0%	0.0%	0.0%	0.0%
% Total	5.3%	90.5%	0.0%	95.8%	0.0%	0.0%	0.0%	0.0%	0.0%	0.0%	0.0%	0.0%	4.2%	0.0%	0.0%	4.2%	0.0%	0.0%	0.0%
PHF	0.625	0.827	0.000	0.827	0.000	0.000	0.000	0.000	0.000	0.000	0.000	0.000	0.667	0.000	0.000	0.667	0.000	0.000	0.848
Lights	9	163	0	172	0	0	0	0	0	0	0	0	7	0	0	7	0	0	179
% Lights	90.0%	94.8%	0.0%	94.5%	0.0%	0.0%	0.0%	0.0%	0.0%	0.0%	0.0%	0.0%	87.5%	0.0%	0.0%	87.5%	0.0%	0.0%	94.2%
Trucks	0	0	0	0	0	0	0	0	0	0	0	0	0	0	0	0	0	0	0
% Trucks	0.0%	0.0%	0.0%	0.0%	0.0%	0.0%	0.0%	0.0%	0.0%	0.0%	0.0%	0.0%	0.0%	0.0%	0.0%	0.0%	0.0%	0.0%	0.0%
Buses	1	8	0	9	0	0	0	0	0	0	0	0	1	0	0	1	0	0	10
% Buses	10.0%	4.7%	0.0%	0.0%	0.0%	0.0%	0.0%	0.0%	0.0%	0.0%	0.0%	0.0%	12.5%	0.0%	0.0%	0.0%	0.0%	0.0%	5.3%
Pedestrians	0	0	0	0	0	0	0	0	0	0	0	0	0	0	0	0	1	1	0
% Pedestrians	0.0%	0.0%	0.0%	0.0%	0.0%	0.0%	0.0%	0.0%	0.0%	0.0%	0.0%	0.0%	0.0%	0.0%	0.0%	0.0%	50.0%	50.0%	0.0%
Bicycles on Crosswalk	0	0	0	0	0	0	0	0	0	0	0	0	0	0	0	0	1	1	0
% Bicycles on Crosswalk	0.0%	0.0%	0.0%	0.0%	0.0%	0.0%	0.0%	0.0%	0.0%	0.0%	0.0%	0.0%	0.0%	0.0%	0.0%	0.0%	50.0%	50.0%	0.0%

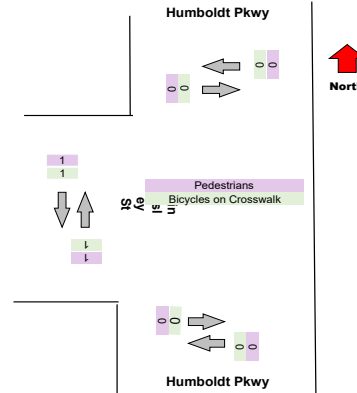
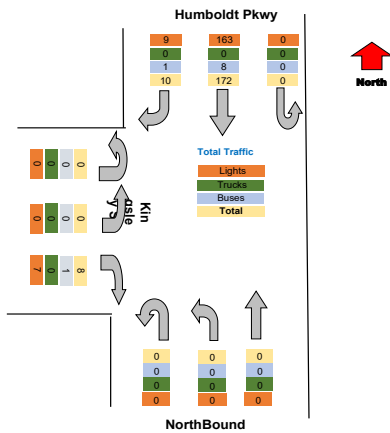





Turning Movement Data Plot

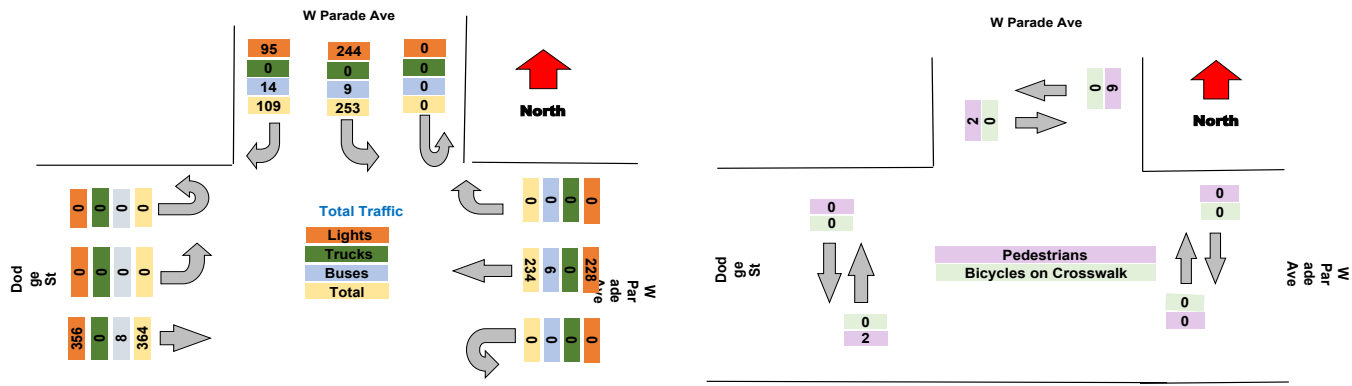

Turning Movement Peak Hour Data (AM)  
 7:30:00 AM

Leg Direction	W Parade Ave Southbound						W Parade Ave Westbound						Dodge St Eastbound						Total
	Right	Left	U-Turn	App Total	Peds CW	Peds CCW	Right	Thru	U-Turn	App Total	Peds CW	Peds CCW	Thru	Left	U-Turn	App Total	Peds CW	Peds CCW	
7:30:00 AM	6	9	0	15	0	0	0	11	0	11	0	0	21	0	0	21	0	0	47
7:45:00 AM	11	21	0	32	1	1	0	16	0	17	0	0	26	0	0	26	0	0	75
8:00:00 AM	8	17	0	25	0	0	0	18	0	18	0	0	27	0	0	27	0	0	70
8:15:00 AM	5	14	0	19	0	0	0	14	0	14	0	0	26	0	0	26	0	0	59
<b>Grand Total</b>	<b>30</b>	<b>61</b>	<b>0</b>	<b>91</b>	<b>1</b>	<b>1</b>	<b>0</b>	<b>59</b>	<b>0</b>	<b>60</b>	<b>0</b>	<b>0</b>	<b>100</b>	<b>0</b>	<b>0</b>	<b>100</b>	<b>0</b>	<b>0</b>	<b>251</b>
% Approach	33.0%	67.0%	0.0%	0.0%	0.0%	0.0%	0.0%	98.3%	0.0%	0.0%	0.0%	0.0%	100.0%	0.0%	0.0%	0.0%	0.0%	0.0%	
% Total	12.0%	24.3%	0.0%	36.3%	0.0%	0.0%	0.0%	23.5%	0.0%	23.9%	0.0%	0.0%	39.8%	0.0%	0.0%	39.8%	0.0%	0.0%	
PHF	0.682	0.726	0.000	0.711	0.000	0.000	0.000	0.819	0.000	0.833	0.000	0.000	0.926	0.000	0.000	0.926	0.000	0.000	0.837
Lights	23	60	0	83	0	0	0	56	0	56	0	0	97	0	0	97	0	0	236
% Lights	76.7%	98.4%	0.0%	91.2%	0.0%	0.0%	0.0%	94.9%	0.0%	93.3%	0.0%	0.0%	97.0%	0.0%	0.0%	97.0%	0.0%	0.0%	94.0%
Trucks	0	0	0	0	0	0	0	0	0	0	0	0	0	0	0	0	0	0	0
% Trucks	0.0%	0.0%	0.0%	0.0%	0.0%	0.0%	0.0%	0.0%	0.0%	0.0%	0.0%	0.0%	0.0%	0.0%	0.0%	0.0%	0.0%	0.0%	0.0%
Buses	7	1	0	8	0	0	0	3	0	3	0	0	3	0	0	3	0	0	14
% Buses	23.3%	1.6%	0.0%	0.0%	0.0%	0.0%	0.0%	5.1%	0.0%	0.0%	0.0%	0.0%	3.0%	0.0%	0.0%	0.0%	0.0%	0.0%	5.6%
Pedestrians	0	0	0	0	1	1	0	0	0	0	0	0	0	0	0	0	0	0	0
% Pedestrians	0.0%	0.0%	0.0%	0.0%	100.0%	100.0%	0.0%	0.0%	0.0%	0.0%	0.0%	0.0%	0.0%	0.0%	0.0%	0.0%	0.0%	0.0%	0.0%
Bicycles on Crosswalk	0	0	0	0	0	0	0	0	0	0	0	0	0	0	0	0	0	0	0
% Bicycles on Crosswalk	0.0%	0.0%	0.0%	0.0%	0.0%	0.0%	0.0%	0.0%	0.0%	0.0%	0.0%	0.0%	0.0%	0.0%	0.0%	0.0%	0.0%	0.0%	0.0%

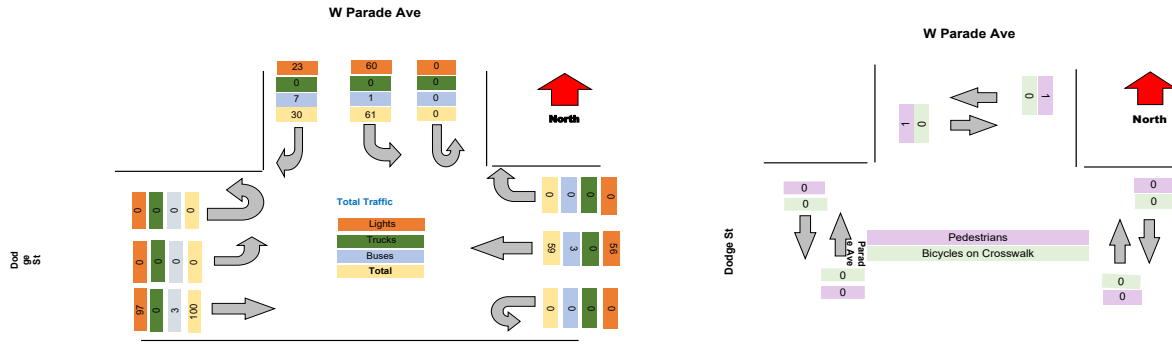

Turning Movement Peak Hour Data (PM)  
 4:30:00 PM

Leg Direction	W Parade Ave Southbound						W Parade Ave Westbound						Dodge St Eastbound						Total
	Right	Left	U-Turn	App Total	Peds CW	Peds CCW	Right	Thru	U-Turn	App Total	Peds CW	Peds CCW	Thru	Left	U-Turn	App Total	Peds CW	Peds CCW	
4:30:00 PM	10	20	0	30	0	1	0	20	0	20	0	0	36	0	0	36	0	0	86
4:45:00 PM	12	15	0	27	0	1	0	22	0	22	0	0	24	0	0	24	1	0	73
5:00:00 PM	8	17	0	25	0	1	0	18	0	18	0	0	28	0	0	28	0	0	71
5:15:00 PM	6	22	0	28	0	0	0	18	0	18	0	0	21	0	0	21	0	0	67
<b>Grand Total</b>	36	74	0	110	0	3	0	78	0	78	0	0	109	0	0	109	1	0	297
% Approach	32.7%	67.3%	0.0%	0.0%	0.0%	0.0%	0.0%	100.0%	0.0%	0.0%	0.0%	0.0%	100.0%	0.0%	0.0%	0.0%	0.0%	0.0%	
% Total	12.1%	24.9%	0.0%	37.0%	0.0%	0.0%	0.0%	26.3%	0.0%	26.3%	0.0%	0.0%	36.7%	0.0%	0.0%	36.7%	0.0%	0.0%	
PHF	0.750	0.841	0.000	0.917	0.000	0.000	0.000	0.886	0.000	0.886	0.000	0.000	0.757	0.000	0.000	0.757	0.000	0.000	0.863
Lights	32	71	0	103	0	0	0	77	0	77	0	0	107	0	0	107	0	0	287
% Lights	88.9%	95.9%	0.0%	93.6%	0.0%	0.0%	0.0%	98.7%	0.0%	98.7%	0.0%	0.0%	98.2%	0.0%	0.0%	98.2%	0.0%	0.0%	96.6%
Trucks	0	0	0	0	0	0	0	0	0	0	0	0	0	0	0	0	0	0	0
% Trucks	0.0%	0.0%	0.0%	0.0%	0.0%	0.0%	0.0%	0.0%	0.0%	0.0%	0.0%	0.0%	0.0%	0.0%	0.0%	0.0%	0.0%	0.0%	0.0%
Buses	4	3	0	7	0	0	0	1	0	1	0	0	2	0	0	2	0	0	10
% Buses	11.1%	4.1%	0.0%	0.0%	0.0%	0.0%	0.0%	1.3%	0.0%	0.0%	0.0%	0.0%	1.8%	0.0%	0.0%	0.0%	0.0%	0.0%	3.4%
Pedestrians	0	0	0	0	0	3	0	0	0	0	0	0	0	0	0	0	1	0	0
% Pedestrians	0.0%	0.0%	0.0%	0.0%	0.0%	100.0%	0.0%	0.0%	0.0%	0.0%	0.0%	0.0%	0.0%	0.0%	0.0%	0.0%	100.0%	0.0%	0.0%
Bicycles on Crosswalk	0	0	0	0	0	0	0	0	0	0	0	0	0	0	0	0	0	0	0
% Bicycles on Crosswalk	0.0%	0.0%	0.0%	0.0%	0.0%	0.0%	0.0%	0.0%	0.0%	0.0%	0.0%	0.0%	0.0%	0.0%	0.0%	0.0%	0.0%	0.0%	0.0%

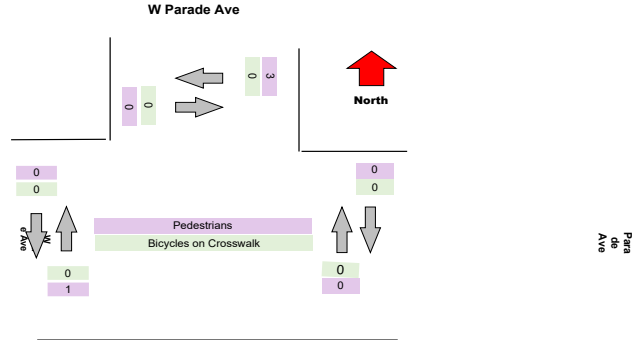
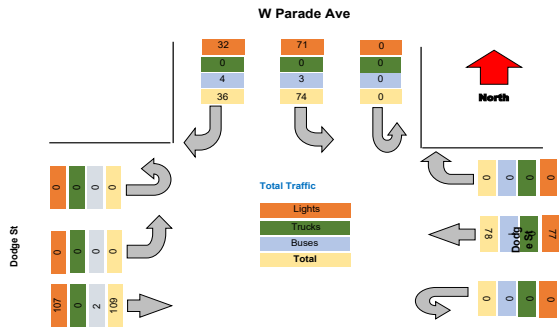

Para Ave

Intersection: Elm St Pine St  
 Location: Kennett Square, PA  
 Site: 01  
 Survey Date: Wednesday, 04-28-2021  
 GPS: 42.948550, -72.790034



Project	LaBella
Project Code	LaBella
Site Name	E
Legs and Movements	All Processed Legs & Movements
Bin Size	15 minutes
Survey Date	2021-10-27, Wednesday
Location	E
Latitude and Longitude	42.905537, -78.845300

	Start	End	PHF
Forced Peak AM	2021/10/27 07:30:00	2021/10/27 08:30:00	0.8409
Forced Peak PM	2021/10/27 16:30:00	2021/10/27 17:30:00	0.8639
AM Peak	2021/10/27 07:30:00	2021/10/27 08:30:00	0.8409
PM Peak	2021/10/27 16:30:00	2021/10/27 17:30:00	0.8639

Turning Movement Data

Leg Direction	W Parade Ave Southbound						W Parade Ave Westbound						Dodge St Eastbound						Total
	Right	Left	U-Turn	App Total	Peds CW	Peds CCW	Right	Thru	U-Turn	App Total	Peds CW	Peds CCW	Thru	Left	U-Turn	App Total	Peds CW	Peds CCW	
Start Time																			
6:30:00 AM	1	6	0	7	0	0	0	6	0	6	0	0	7	0	0	7	0	0	20
6:45:00 AM	5	8	0	13	0	0	0	6	0	6	0	1	8	0	0	9	0	0	28
<b>Hourly Total</b>	<b>6</b>	<b>14</b>	<b>0</b>	<b>20</b>	<b>0</b>	<b>0</b>	<b>0</b>	<b>12</b>	<b>0</b>	<b>12</b>	<b>0</b>	<b>1</b>	<b>15</b>	<b>0</b>	<b>0</b>	<b>16</b>	<b>0</b>	<b>0</b>	<b>48</b>
7:00:00 AM	0	9	0	9	1	0	0	4	0	4	0	0	11	0	0	11	0	0	24
7:15:00 AM	4	13	0	17	0	0	0	10	0	10	0	0	15	0	0	15	0	0	42
7:30:00 AM	2	6	0	8	2	0	1	15	0	16	0	0	15	0	0	15	0	0	39
7:45:00 AM	14	14	0	28	4	0	0	9	0	9	0	0	24	0	0	24	0	0	61
<b>Hourly Total</b>	<b>20</b>	<b>42</b>	<b>0</b>	<b>62</b>	<b>7</b>	<b>0</b>	<b>1</b>	<b>38</b>	<b>0</b>	<b>39</b>	<b>0</b>	<b>0</b>	<b>65</b>	<b>0</b>	<b>0</b>	<b>65</b>	<b>0</b>	<b>0</b>	<b>166</b>
8:00:00 AM	8	14	0	22	0	0	0	13	0	13	0	0	21	0	0	21	0	0	56
8:15:00 AM	4	13	0	17	0	1	0	20	0	21	0	0	28	0	0	28	0	0	66
<b>Hourly Total</b>	<b>12</b>	<b>27</b>	<b>0</b>	<b>39</b>	<b>0</b>	<b>1</b>	<b>0</b>	<b>33</b>	<b>0</b>	<b>34</b>	<b>0</b>	<b>0</b>	<b>49</b>	<b>0</b>	<b>0</b>	<b>49</b>	<b>0</b>	<b>0</b>	<b>122</b>
4:00:00 PM	13	23	0	36	0	1	0	26	0	26	0	0	63	0	0	63	0	0	125
4:15:00 PM	10	21	0	31	0	2	0	18	0	18	0	0	35	0	0	35	0	0	84
4:30:00 PM	10	26	0	36	0	0	0	17	0	17	0	0	37	0	0	37	0	0	90
4:45:00 PM	13	27	0	40	2	1	0	24	0	24	0	0	37	0	0	37	0	0	101
<b>Hourly Total</b>	<b>46</b>	<b>97</b>	<b>0</b>	<b>143</b>	<b>2</b>	<b>4</b>	<b>0</b>	<b>85</b>	<b>0</b>	<b>85</b>	<b>0</b>	<b>0</b>	<b>172</b>	<b>0</b>	<b>0</b>	<b>172</b>	<b>0</b>	<b>0</b>	<b>400</b>
5:00:00 PM	6	15	0	21	0	1	0	18	0	18	0	0	31	0	0	31	0	0	70
5:15:00 PM	11	18	0	29	1	0	0	21	0	21	0	0	38	0	0	38	0	0	88
5:30:00 PM	9	19	0	28	0	1	0	23	0	23	0	0	24	0	0	24	0	0	75
5:45:00 PM	11	10	0	21	0	0	0	20	0	20	0	0	21	0	0	21	0	0	62
<b>Hourly Total</b>	<b>37</b>	<b>62</b>	<b>0</b>	<b>99</b>	<b>1</b>	<b>2</b>	<b>0</b>	<b>82</b>	<b>0</b>	<b>82</b>	<b>0</b>	<b>0</b>	<b>114</b>	<b>0</b>	<b>0</b>	<b>114</b>	<b>0</b>	<b>0</b>	<b>295</b>
<b>Grand Total</b>	<b>121</b>	<b>242</b>	<b>0</b>	<b>363</b>	<b>10</b>	<b>7</b>	<b>1</b>	<b>250</b>	<b>0</b>	<b>252</b>	<b>0</b>	<b>1</b>	<b>415</b>	<b>0</b>	<b>0</b>	<b>416</b>	<b>0</b>	<b>0</b>	<b>1031</b>
<b>% Approach</b>	<b>33.3%</b>	<b>66.7%</b>	<b>0.0%</b>	<b>0.0%</b>	<b>0.0%</b>	<b>0.0%</b>	<b>0.4%</b>	<b>99.2%</b>	<b>0.0%</b>	<b>0.0%</b>	<b>0.0%</b>	<b>0.0%</b>	<b>99.8%</b>	<b>0.0%</b>	<b>0.0%</b>	<b>0.0%</b>	<b>0.0%</b>	<b>0.0%</b>	<b>0.0%</b>
<b>% Total</b>	<b>11.7%</b>	<b>23.5%</b>	<b>0.0%</b>	<b>35.2%</b>	<b>0.0%</b>	<b>0.0%</b>	<b>0.1%</b>	<b>24.2%</b>	<b>0.0%</b>	<b>24.4%</b>	<b>0.0%</b>	<b>0.0%</b>	<b>40.3%</b>	<b>0.0%</b>	<b>0.0%</b>	<b>40.3%</b>	<b>0.0%</b>	<b>0.0%</b>	<b>0.0%</b>
<b>Lights</b>	<b>104</b>	<b>232</b>	<b>0</b>	<b>336</b>	<b>0</b>	<b>0</b>	<b>1</b>	<b>242</b>	<b>0</b>	<b>243</b>	<b>0</b>	<b>0</b>	<b>403</b>	<b>0</b>	<b>0</b>	<b>403</b>	<b>0</b>	<b>0</b>	<b>982</b>
<b>% Lights</b>	<b>86.0%</b>	<b>95.9%</b>	<b>0.0%</b>	<b>92.6%</b>	<b>0.0%</b>	<b>0.0%</b>	<b>100.0%</b>	<b>96.8%</b>	<b>0.0%</b>	<b>96.4%</b>	<b>0.0%</b>	<b>0.0%</b>	<b>97.1%</b>	<b>0.0%</b>	<b>0.0%</b>	<b>96.9%</b>	<b>0.0%</b>	<b>0.0%</b>	<b>95.2%</b>
<b>Trucks</b>	<b>0</b>	<b>0</b>	<b>0</b>	<b>0</b>	<b>0</b>	<b>0</b>	<b>0</b>	<b>1</b>	<b>0</b>	<b>1</b>	<b>0</b>	<b>0</b>	<b>0</b>	<b>0</b>	<b>0</b>	<b>0</b>	<b>0</b>	<b>0</b>	<b>1</b>
<b>% Trucks</b>	<b>0.0%</b>	<b>0.0%</b>	<b>0.0%</b>	<b>0.0%</b>	<b>0.0%</b>	<b>0.0%</b>	<b>0.0%</b>	<b>0.4%</b>	<b>0.0%</b>	<b>0.4%</b>	<b>0.0%</b>	<b>0.0%</b>	<b>0.0%</b>	<b>0.0%</b>	<b>0.0%</b>	<b>0.0%</b>	<b>0.0%</b>	<b>0.0%</b>	<b>0.1%</b>
<b>Buses</b>	<b>17</b>	<b>9</b>	<b>0</b>	<b>26</b>	<b>0</b>	<b>0</b>	<b>0</b>	<b>7</b>	<b>0</b>	<b>7</b>	<b>0</b>	<b>0</b>	<b>11</b>	<b>0</b>	<b>0</b>	<b>11</b>	<b>0</b>	<b>0</b>	<b>44</b>
<b>% Buses</b>	<b>14.0%</b>	<b>3.7%</b>	<b>0.0%</b>	<b>0.0%</b>	<b>0.0%</b>	<b>0.0%</b>	<b>0.0%</b>	<b>2.8%</b>	<b>0.0%</b>	<b>0.0%</b>	<b>0.0%</b>	<b>0.0%</b>	<b>2.7%</b>	<b>0.0%</b>	<b>0.0%</b>	<b>0.0%</b>	<b>0.0%</b>	<b>0.0%</b>	<b>4.3%</b>
<b>Pedestrians</b>	<b>0</b>	<b>0</b>	<b>0</b>	<b>0</b>	<b>10</b>	<b>6</b>	<b>0</b>	<b>0</b>	<b>0</b>	<b>0</b>	<b>0</b>	<b>1</b>	<b>0</b>	<b>0</b>	<b>0</b>	<b>0</b>	<b>0</b>	<b>0</b>	<b>0</b>
<b>% Pedestrians</b>	<b>0.0%</b>	<b>0.0%</b>	<b>0.0%</b>	<b>0.0%</b>	<b>100.0%</b>	<b>85.7%</b>	<b>0.0%</b>	<b>0.0%</b>	<b>0.0%</b>	<b>0.0%</b>	<b>0.0%</b>	<b>100.0%</b>	<b>0.0%</b>	<b>0.0%</b>	<b>0.0%</b>	<b>0.0%</b>	<b>0.0%</b>	<b>0.0%</b>	<b>0.0%</b>
<b>Bicycles on Crosswalk</b>	<b>0</b>	<b>0</b>	<b>0</b>	<b>0</b>	<b>0</b>	<b>1</b>	<b>0</b>	<b>0</b>	<b>0</b>	<b>0</b>	<b>0</b>	<b>0</b>	<b>0</b>	<b>0</b>	<b>0</b>	<b>0</b>	<b>0</b>	<b>0</b>	<b>0</b>
<b>% Bicycles on Crosswalk</b>	<b>0.0%</b>	<b>0.0%</b>	<b>0.0%</b>	<b>0.0%</b>	<b>0.0%</b>	<b>14.3%</b>	<b>0.0%</b>	<b>0.0%</b>	<b>0.0%</b>	<b>0.0%</b>	<b>0.0%</b>	<b>0.0%</b>	<b>0.0%</b>	<b>0.0%</b>	<b>0.0%</b>	<b>0.0%</b>	<b>0.0%</b>	<b>0.0%</b>	<b>0.0%</b>

Turning Movement Data Plot

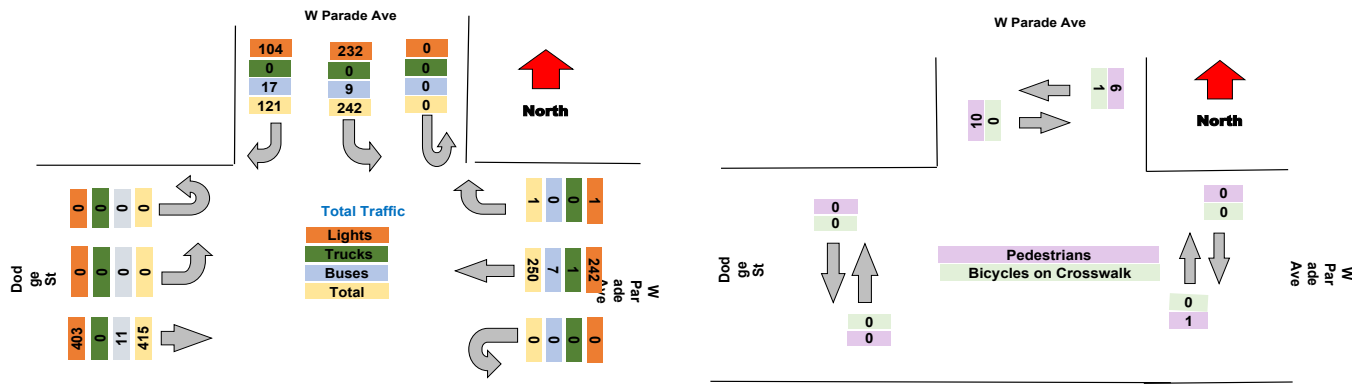

Turning Movement Peak Hour Data (AM)

7:30:00 AM

Leg Direction	W Parade Ave Southbound						W Parade Ave Westbound						Dodge St Eastbound						Total
	Right	Left	U-Turn	App Total	Peds CW	Peds CCW	Right	Thru	U-Turn	App Total	Peds CW	Peds CCW	Thru	Left	U-Turn	App Total	Peds CW	Peds CCW	
7:30:00 AM	2	6	0	8	2	0	1	15	0	16	0	0	15	0	0	15	0	0	39
7:45:00 AM	14	14	0	28	4	0	0	9	0	9	0	0	24	0	0	24	0	0	61
8:00:00 AM	8	14	0	22	0	0	0	13	0	13	0	0	21	0	0	21	0	0	56
8:15:00 AM	4	13	0	17	0	1	0	20	0	21	0	0	28	0	0	28	0	0	66
<b>Grand Total</b>	28	47	0	75	6	1	1	57	0	59	0	0	88	0	0	88	0	0	222
% Approach	37.3%	62.7%	0.0%	0.0%	0.0%	0.0%	1.7%	96.6%	0.0%	0.0%	0.0%	0.0%	100.0%	0.0%	0.0%	0.0%	0.0%	0.0%	
% Total	12.6%	21.2%	0.0%	33.8%	0.0%	0.0%	0.5%	25.7%	0.0%	26.6%	0.0%	0.0%	39.6%	0.0%	0.0%	39.6%	0.0%	0.0%	
PHF	0.500	0.839	0.000	0.670	0.000	0.000	0.250	0.713	0.000	0.702	0.000	0.000	0.786	0.000	0.000	0.786	0.000	0.000	0.841
Lights	22	46	0	68	0	0	1	55	0	56	0	0	85	0	0	85	0	0	209
% Lights	78.6%	97.9%	0.0%	90.7%	0.0%	0.0%	100.0%	96.5%	0.0%	94.9%	0.0%	0.0%	96.6%	0.0%	0.0%	96.6%	0.0%	0.0%	94.1%
Trucks	0	0	0	0	0	0	0	0	0	0	0	0	0	0	0	0	0	0	0
% Trucks	0.0%	0.0%	0.0%	0.0%	0.0%	0.0%	0.0%	0.0%	0.0%	0.0%	0.0%	0.0%	0.0%	0.0%	0.0%	0.0%	0.0%	0.0%	0.0%
Buses	6	1	0	7	0	0	0	2	0	2	0	0	3	0	0	3	0	0	12
% Buses	21.4%	2.1%	0.0%	0.0%	0.0%	0.0%	0.0%	3.5%	0.0%	0.0%	0.0%	0.0%	3.4%	0.0%	0.0%	0.0%	0.0%	0.0%	5.4%
Pedestrians	0	0	0	0	6	1	0	0	0	0	0	0	0	0	0	0	0	0	0
% Pedestrians	0.0%	0.0%	0.0%	0.0%	100.0%	100.0%	0.0%	0.0%	0.0%	0.0%	0.0%	0.0%	0.0%	0.0%	0.0%	0.0%	0.0%	0.0%	0.0%
Bicycles on Crosswalk	0	0	0	0	0	0	0	0	0	0	0	0	0	0	0	0	0	0	0
% Bicycles on Crosswalk	0.0%	0.0%	0.0%	0.0%	0.0%	0.0%	0.0%	0.0%	0.0%	0.0%	0.0%	0.0%	0.0%	0.0%	0.0%	0.0%	0.0%	0.0%	0.0%

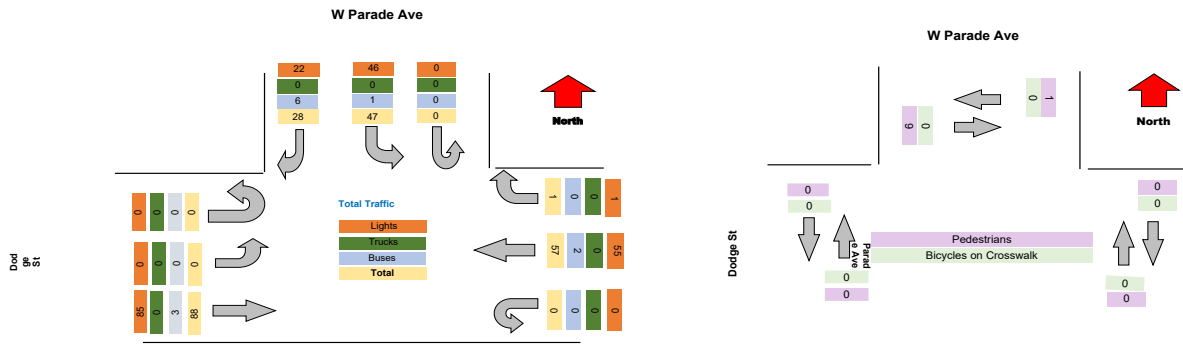

Turning Movement Peak Hour Data (PM)  
 4:30:00 PM

Leg Direction	W Parade Ave Southbound						W Parade Ave Westbound						Dodge St Eastbound						Total
	Right	Left	U-Turn	App Total	Peds CW	Peds CCW	Right	Thru	U-Turn	App Total	Peds CW	Peds CCW	Thru	Left	U-Turn	App Total	Peds CW	Peds CCW	
4:30:00 PM	10	26	0	36	0	0	0	17	0	17	0	0	37	0	0	37	0	0	90
4:45:00 PM	13	27	0	40	2	1	0	24	0	24	0	0	37	0	0	37	0	0	101
5:00:00 PM	6	15	0	21	0	1	0	18	0	18	0	0	31	0	0	31	0	0	70
5:15:00 PM	11	18	0	29	1	0	0	21	0	21	0	0	38	0	0	38	0	0	88
<b>Grand Total</b>	<b>40</b>	<b>86</b>	<b>0</b>	<b>126</b>	<b>3</b>	<b>2</b>	<b>0</b>	<b>80</b>	<b>0</b>	<b>80</b>	<b>0</b>	<b>0</b>	<b>143</b>	<b>0</b>	<b>0</b>	<b>143</b>	<b>0</b>	<b>0</b>	<b>349</b>
% Approach	31.7%	68.3%	0.0%	0.0%	0.0%	0.0%	0.0%	100.0%	0.0%	0.0%	0.0%	0.0%	100.0%	0.0%	0.0%	0.0%	0.0%	0.0%	
% Total	11.5%	24.6%	0.0%	36.1%	0.0%	0.0%	0.0%	22.9%	0.0%	22.9%	0.0%	0.0%	41.0%	0.0%	0.0%	41.0%	0.0%	0.0%	
PHF	0.769	0.796	0.000	0.788	0.000	0.000	0.000	0.833	0.000	0.833	0.000	0.000	0.941	0.000	0.000	0.941	0.000	0.000	0.864
Lights	33	84	0	117	0	0	0	78	0	78	0	0	139	0	0	139	0	0	334
% Lights	82.5%	97.7%	0.0%	92.9%	0.0%	0.0%	0.0%	97.5%	0.0%	97.5%	0.0%	0.0%	97.2%	0.0%	0.0%	97.2%	0.0%	0.0%	95.7%
Trucks	0	0	0	0	0	0	0	0	0	0	0	0	0	0	0	0	0	0	0
% Trucks	0.0%	0.0%	0.0%	0.0%	0.0%	0.0%	0.0%	0.0%	0.0%	0.0%	0.0%	0.0%	0.0%	0.0%	0.0%	0.0%	0.0%	0.0%	0.0%
Buses	7	1	0	8	0	0	0	2	0	2	0	0	3	0	0	3	0	0	13
% Buses	17.5%	1.2%	0.0%	0.0%	0.0%	0.0%	0.0%	2.5%	0.0%	0.0%	0.0%	0.0%	2.1%	0.0%	0.0%	0.0%	0.0%	0.0%	3.7%
Pedestrians	0	0	0	0	3	1	0	0	0	0	0	0	0	0	0	0	0	0	0
% Pedestrians	0.0%	0.0%	0.0%	0.0%	100.0%	50.0%	0.0%	0.0%	0.0%	0.0%	0.0%	0.0%	0.0%	0.0%	0.0%	0.0%	0.0%	0.0%	0.0%
Bicycles on Crosswalk	0	0	0	0	0	1	0	0	0	0	0	0	0	0	0	0	0	0	0
% Bicycles on Crosswalk	0.0%	0.0%	0.0%	0.0%	0.0%	50.0%	0.0%	0.0%	0.0%	0.0%	0.0%	0.0%	0.0%	0.0%	0.0%	0.0%	0.0%	0.0%	0.0%

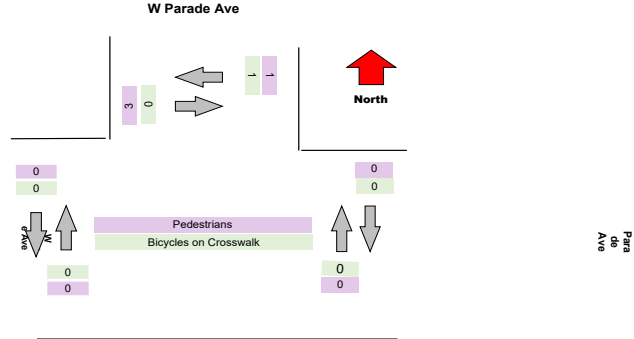
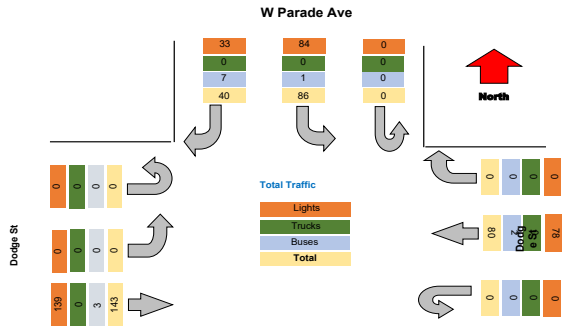



Intersection: Elm St Pine St  
 Location: Kennett Square, PA  
 Site: 01  
 Survey Date: Wednesday, 04-28-2021  
 GPS: 42.948550, -72.790034



Project	LaBella
Project Code	LaBella
Site Name	E
Legs and Movements	All Processed Legs & Movements
Bin Size	15 minutes
Survey Date	2021-10-28, Thursday
Location	E
Latitude and Longitude	42.905537, -78.845300

	Start	End	PHF
Forced Peak AM	2021/10/28 07:30:00	2021/10/28 08:30:00	0.7992
Forced Peak PM	2021/10/28 16:30:00	2021/10/28 17:30:00	0.8801
AM Peak	2021/10/28 07:30:00	2021/10/28 08:30:00	0.7992
PM Peak	2021/10/28 16:30:00	2021/10/28 17:30:00	0.8801

Turning Movement Data

Leg Direction	W Parade Ave Southbound					W Parade Ave Westbound					Dodge St Eastbound					Total
	Right	Left	U-Turn	App Total	Peds CW/Peds CCW	Right	Thru	U-Turn	App Total	Peds CW/Peds CCW	Thru	Left	U-Turn	App Total	Peds CW/Peds CCW	
Start Time																
6:30:00 AM	3	6	0	9	0 0	0	2	0	2	0 0	8	0	0	8	0 0	19
6:45:00 AM	5	5	0	10	0 0	0	2	0	2	0 1	6	0	0	7	0 0	19
Hourly Total	8	11	0	19	0 0	0	4	0	4	0 1	14	0	0	15	0 0	38
7:00:00 AM	2	9	0	11	0 0	0	8	0	8	0 0	16	0	0	16	0 0	35
7:15:00 AM	4	7	0	11	1 0	0	11	0	11	0 0	12	0	0	12	0 0	34
7:30:00 AM	7	5	0	12	1 0	0	7	0	7	0 0	13	0	0	13	0 0	32
7:45:00 AM	8	13	0	21	4 0	0	13	0	13	1 0	26	0	0	27	0 0	61
Hourly Total	21	34	0	55	6 0	0	39	0	39	1 0	67	0	0	68	0 0	162
8:00:00 AM	7	15	0	22	0 0	0	17	0	17	0 0	20	0	0	20	0 0	59
8:15:00 AM	0	15	0	15	0 1	0	12	0	13	0 0	15	0	0	15	0 0	43
Hourly Total	7	30	0	37	0 1	0	29	0	30	0 0	35	0	0	35	0 0	102
4:00:00 PM	10	24	0	34	0 1	0	21	0	21	0 0	49	0	0	49	0 0	104
4:15:00 PM	8	21	0	29	4 0	0	18	0	18	0 0	50	0	0	50	0 0	97
4:30:00 PM	15	23	0	38	2 2	0	25	0	25	0 0	35	0	0	35	0 1	98
4:45:00 PM	8	16	0	24	2 0	0	28	0	28	0 0	32	0	0	32	0 1	84
Hourly Total	41	84	0	125	8 3	0	92	0	92	0 0	166	0	0	166	0 2	383
5:00:00 PM	5	19	0	24	0 0	0	22	0	22	0 0	31	0	0	31	0 0	77
5:15:00 PM	10	20	0	30	0 0	0	22	0	22	0 0	34	0	0	34	0 0	86
5:30:00 PM	8	17	0	25	1 1	0	28	0	28	0 0	23	0	0	23	0 0	76
5:45:00 PM	11	17	0	28	0 0	0	21	0	21	0 0	23	0	0	23	0 0	72
Hourly Total	34	73	0	107	1 1	0	93	0	93	0 0	111	0	0	111	0 0	311
Grand Total	111	232	0	343	15 5	0	257	0	258	1 1	393	0	0	395	0 2	996
% Approach	32.4%	67.6%	0.0%	0.0%	0.0%	0.0%	99.6%	0.0%	0.0%	0.0%	99.5%	0.0%	0.0%	0.0%	0.0%	0.0%
% Total	11.1%	23.3%	0.0%	34.4%	0.0%	0.0%	25.8%	0.0%	25.9%	0.0%	39.5%	0.0%	0.0%	39.7%	0.0%	0.0%
Lights	96	220	0	316	0 0	0	248	0	248	0 0	384	0	0	384	0 0	948
% Lights	86.5%	94.8%	0.0%	92.1%	0.0%	0.0%	96.5%	0.0%	96.1%	0.0%	97.7%	0.0%	0.0%	97.2%	0.0%	95.2%
Trucks	0	0	0	0	0 0	0	0	0	0	0 0	0	0	0	0	0 0	0
% Trucks	0.0%	0.0%	0.0%	0.0%	0.0%	0.0%	0.0%	0.0%	0.0%	0.0%	0.0%	0.0%	0.0%	0.0%	0.0%	0.0%
Buses	15	11	0	26	0 0	0	9	0	9	0 0	9	0	0	9	0 0	44
% Buses	13.5%	4.7%	0.0%	0.0%	0.0%	0.0%	3.5%	0.0%	0.0%	0.0%	2.3%	0.0%	0.0%	0.0%	0.0%	4.4%
Pedestrians	0	0	0	0	15 5	0	0	0	0	1 1	0	0	0	0	0 1	0
% Pedestrians	0.0%	0.0%	0.0%	0.0%	100.0%	0.0%	0.0%	0.0%	0.0%	100.0%	0.0%	0.0%	0.0%	0.0%	50.0%	0.0%
Bicycles on Crosswalk	0	0	0	0	0 0	0	0	0	0	0 0	0	0	0	0	0 1	0
% Bicycles on Crosswalk	0.0%	0.0%	0.0%	0.0%	0.0%	0.0%	0.0%	0.0%	0.0%	0.0%	0.0%	0.0%	0.0%	0.0%	50.0%	0.0%

Turning Movement Data Plot

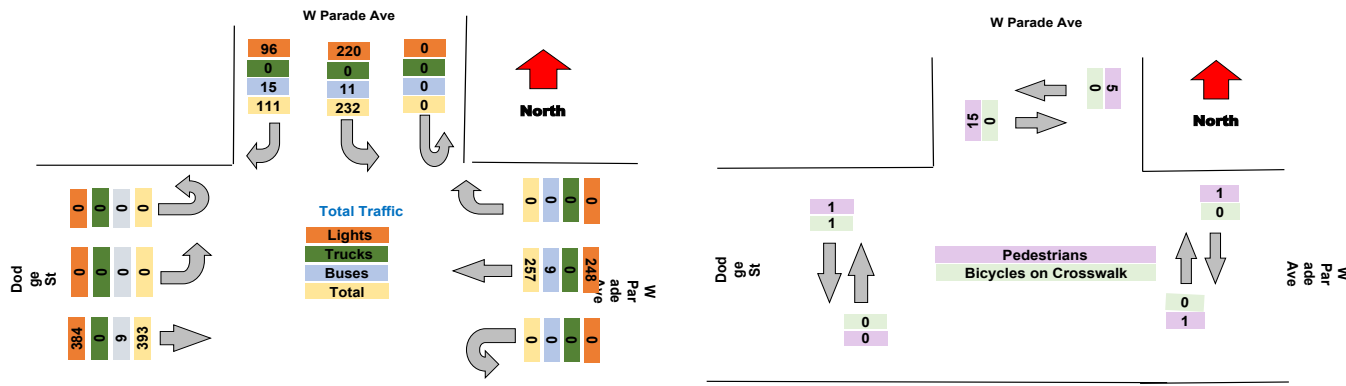

Turning Movement Peak Hour Data (AM)

7:30:00 AM

Leg Direction	W Parade Ave Southbound						W Parade Ave Westbound						Dodge St Eastbound						Total
	Right	Left	U-Turn	App Total	Peds CW	Peds CCW	Right	Thru	U-Turn	App Total	Peds CW	Peds CCW	Thru	Left	U-Turn	App Total	Peds CW	Peds CCW	
7:30:00 AM	7	5	0	12	1	0	0	7	0	7	0	0	13	0	0	13	0	0	32
7:45:00 AM	8	13	0	21	4	0	0	13	0	13	1	0	26	0	0	27	0	0	61
8:00:00 AM	7	15	0	22	0	0	0	17	0	17	0	0	20	0	0	20	0	0	59
8:15:00 AM	0	15	0	15	0	1	0	12	0	13	0	0	15	0	0	15	0	0	43
<b>Grand Total</b>	<b>22</b>	<b>48</b>	<b>0</b>	<b>70</b>	<b>5</b>	<b>1</b>	<b>0</b>	<b>49</b>	<b>0</b>	<b>50</b>	<b>1</b>	<b>0</b>	<b>74</b>	<b>0</b>	<b>0</b>	<b>75</b>	<b>0</b>	<b>0</b>	<b>195</b>
% Approach	31.4%	68.6%	0.0%	0.0%	0.0%	0.0%	0.0%	98.0%	0.0%	0.0%	0.0%	0.0%	98.7%	0.0%	0.0%	0.0%	0.0%	0.0%	
% Total	11.3%	24.6%	0.0%	35.9%	0.0%	0.0%	0.0%	25.1%	0.0%	25.6%	0.0%	0.0%	37.9%	0.0%	0.0%	38.5%	0.0%	0.0%	
PHF	0.688	0.800	0.000	0.795	0.000	0.000	0.000	0.721	0.000	0.735	0.000	0.000	0.712	0.000	0.000	0.694	0.000	0.000	0.799
Lights	15	47	0	62	0	0	0	46	0	46	0	0	72	0	0	72	0	0	180
% Lights	68.2%	97.9%	0.0%	88.6%	0.0%	0.0%	0.0%	93.9%	0.0%	92.0%	0.0%	0.0%	97.3%	0.0%	0.0%	96.0%	0.0%	0.0%	92.3%
Trucks	0	0	0	0	0	0	0	0	0	0	0	0	0	0	0	0	0	0	0
% Trucks	0.0%	0.0%	0.0%	0.0%	0.0%	0.0%	0.0%	0.0%	0.0%	0.0%	0.0%	0.0%	0.0%	0.0%	0.0%	0.0%	0.0%	0.0%	0.0%
Buses	7	1	0	8	0	0	0	3	0	3	0	0	2	0	0	2	0	0	13
% Buses	31.8%	2.1%	0.0%	0.0%	0.0%	0.0%	0.0%	6.1%	0.0%	0.0%	0.0%	0.0%	2.7%	0.0%	0.0%	0.0%	0.0%	0.0%	6.7%
Pedestrians	0	0	0	0	5	1	0	0	0	1	0	0	0	0	0	0	0	0	0
% Pedestrians	0.0%	0.0%	0.0%	0.0%	100.0%	100.0%	0.0%	0.0%	0.0%	0.0%	100.0%	0.0%	0.0%	0.0%	0.0%	0.0%	0.0%	0.0%	0.0%
Bicycles on Crosswalk	0	0	0	0	0	0	0	0	0	0	0	0	0	0	0	0	0	0	0
% Bicycles on Crosswalk	0.0%	0.0%	0.0%	0.0%	0.0%	0.0%	0.0%	0.0%	0.0%	0.0%	0.0%	0.0%	0.0%	0.0%	0.0%	0.0%	0.0%	0.0%	0.0%

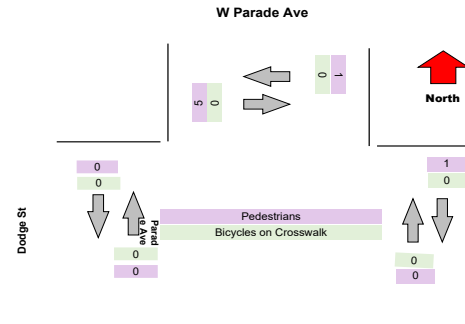
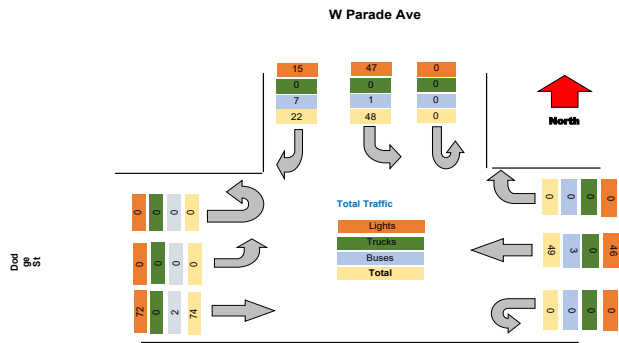

Turning Movement Peak Hour Data (PM)  
 4:30:00 PM

Leg Direction	W Parade Ave Southbound						W Parade Ave Westbound						Dodge St Eastbound						Total
	Right	Left	U-Turn	App Total	Peds CW	Peds CCW	Right	Thru	U-Turn	App Total	Peds CW	Peds CCW	Thru	Left	U-Turn	App Total	Peds CW	Peds CCW	
4:30:00 PM	15	23	0	38	2	2	0	25	0	25	0	0	35	0	0	35	0	1	98
4:45:00 PM	8	16	0	24	2	0	0	28	0	28	0	0	32	0	0	32	0	1	84
5:00:00 PM	5	19	0	24	0	0	0	22	0	22	0	0	31	0	0	31	0	0	77
5:15:00 PM	10	20	0	30	0	0	0	22	0	22	0	0	34	0	0	34	0	0	86
<b>Grand Total</b>	<b>38</b>	<b>78</b>	<b>0</b>	<b>116</b>	<b>4</b>	<b>2</b>	<b>0</b>	<b>97</b>	<b>0</b>	<b>97</b>	<b>0</b>	<b>0</b>	<b>132</b>	<b>0</b>	<b>0</b>	<b>132</b>	<b>0</b>	<b>2</b>	<b>345</b>
% Approach	32.8%	67.2%	0.0%	0.0%	0.0%	0.0%	0.0%	100.0%	0.0%	0.0%	0.0%	0.0%	100.0%	0.0%	0.0%	0.0%	0.0%	0.0%	0.0%
% Total	11.0%	22.6%	0.0%	33.6%	0.0%	0.0%	0.0%	28.1%	0.0%	28.1%	0.0%	0.0%	38.3%	0.0%	0.0%	38.3%	0.0%	0.0%	0.0%
PHF	0.633	0.848	0.000	0.763	0.000	0.000	0.000	0.866	0.000	0.866	0.000	0.000	0.943	0.000	0.000	0.943	0.000	0.000	0.000
Lights	32	76	0	108	0	0	0	93	0	93	0	0	130	0	0	130	0	0	331
% Lights	84.2%	97.4%	0.0%	93.1%	0.0%	0.0%	0.0%	95.9%	0.0%	95.9%	0.0%	0.0%	98.5%	0.0%	0.0%	98.5%	0.0%	0.0%	95.9%
Trucks	0	0	0	0	0	0	0	0	0	0	0	0	0	0	0	0	0	0	0
% Trucks	0.0%	0.0%	0.0%	0.0%	0.0%	0.0%	0.0%	0.0%	0.0%	0.0%	0.0%	0.0%	0.0%	0.0%	0.0%	0.0%	0.0%	0.0%	0.0%
Buses	6	1	0	7	0	0	0	4	0	4	0	0	2	0	0	2	0	0	13
% Buses	15.8%	1.3%	0.0%	0.0%	0.0%	0.0%	0.0%	4.1%	0.0%	0.0%	0.0%	0.0%	1.5%	0.0%	0.0%	0.0%	0.0%	0.0%	3.8%
Pedestrians	0	0	0	0	4	2	0	0	0	0	0	0	0	0	0	0	0	1	0
% Pedestrians	0.0%	0.0%	0.0%	0.0%	100.0%	100.0%	0.0%	0.0%	0.0%	0.0%	0.0%	0.0%	0.0%	0.0%	0.0%	0.0%	0.0%	50.0%	0.0%
Bicycles on Crosswalk	0	0	0	0	0	0	0	0	0	0	0	0	0	0	0	0	0	1	0
% Bicycles on Crosswalk	0.0%	0.0%	0.0%	0.0%	0.0%	0.0%	0.0%	0.0%	0.0%	0.0%	0.0%	0.0%	0.0%	0.0%	0.0%	0.0%	0.0%	50.0%	0.0%

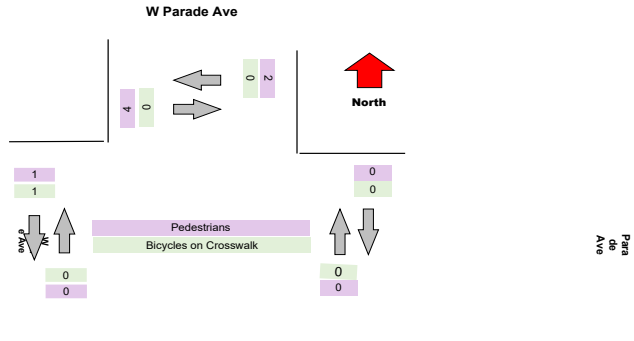
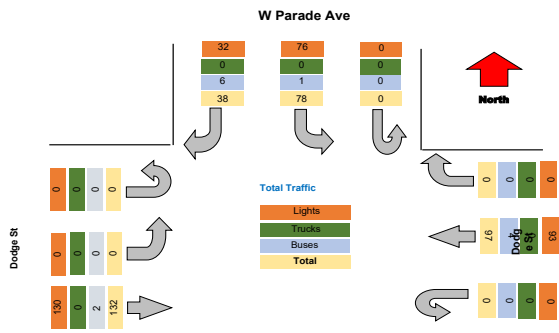



Turning Movement Data Plot

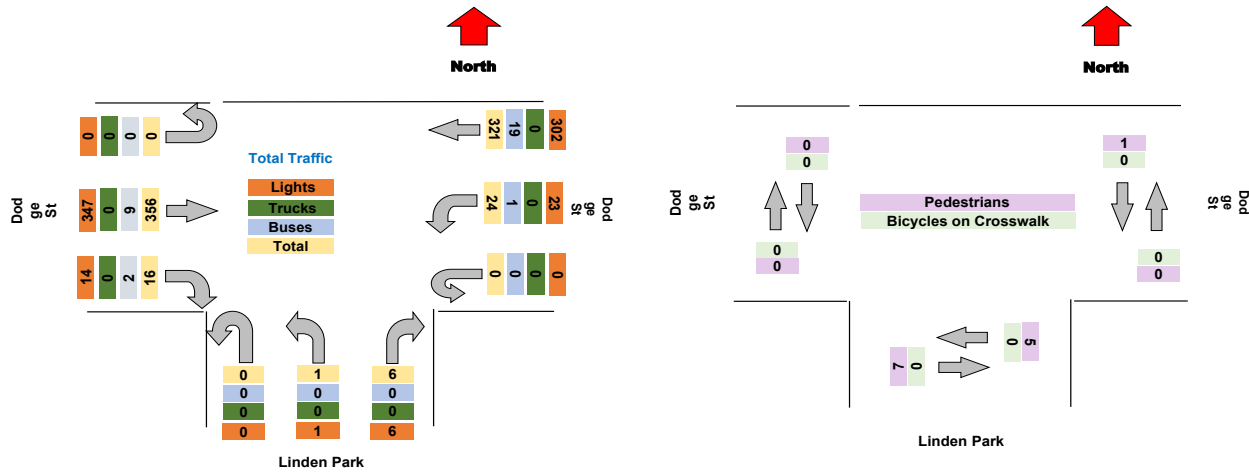

Turning Movement Peak Hour Data (AM)  
7:30:00 AM

Leg Direction	Dodge St Westbound						Linden Park Northbound						Dodge St Eastbound						Total
	Thru	Left	U-Turn	App Total	Peds CW	Peds CCW	Right	Left	U-Turn	App Total	Peds CW	Peds CCW	Right	Thru	U-Turn	App Total	Peds CW	Peds CCW	
7:30:00 AM	19	1	0	20	0	0	0	0	0	0	0	1	0	22	0	23	0	0	43
7:45:00 AM	25	1	0	26	0	0	0	0	0	0	1	1	0	25	0	27	0	0	53
8:00:00 AM	26	1	0	27	0	0	2	0	2	1	0	0	1	25	0	27	0	0	56
8:15:00 AM	17	2	0	19	0	0	1	0	1	0	0	0	1	25	0	26	0	0	46
<b>Grand Total</b>	87	5	0	92	0	0	3	0	3	2	2	2	2	97	0	103	0	0	198
% Approach	94.6%	5.4%	0.0%	0.0%	0.0%	0.0%	14.2%	0.0%	0.0%	0.0%	0.0%	0.0%	45.1%	41.7%	0.0%	0.0%	0.0%	0.0%	
% Total	43.9%	2.5%	0.0%	46.5%	0.0%	0.0%	1.5%	0.0%	0.0%	1.5%	0.0%	0.0%	1.0%	49.0%	0.0%	52.0%	0.0%	0.0%	
PHF	0.837	0.625	0.000	0.852	0.000	0.000	0.375	0.000	0.000	0.375	0.000	0.000	0.500	0.970	0.000	0.954	0.000	0.000	0.884
Lights	77	5	0	82	0	0	3	0	3	0	0	0	2	94	0	96	0	0	181
% Lights	88.5%	100.0%	0.0%	89.1%	0.0%	0.0%	100.0%	0.0%	0.0%	100.0%	0.0%	0.0%	100.0%	96.9%	0.0%	93.2%	0.0%	0.0%	91.4%
Trucks	0	0	0	0	0	0	0	0	0	0	0	0	0	0	0	0	0	0	0
% Trucks	0.0%	0.0%	0.0%	0.0%	0.0%	0.0%	0.0%	0.0%	0.0%	0.0%	0.0%	0.0%	0.0%	0.0%	0.0%	0.0%	0.0%	0.0%	0.0%
Buses	10	0	0	10	0	0	0	0	0	0	0	0	3	0	3	0	0	0	13
% Buses	11.5%	0.0%	0.0%	0.0%	0.0%	0.0%	0.0%	0.0%	0.0%	0.0%	0.0%	0.0%	0.0%	3.1%	0.0%	0.0%	0.0%	0.0%	6.6%
Pedestrians	0	0	0	0	0	0	0	0	0	2	2	0	0	0	0	0	0	0	0
% Pedestrians	0.0%	0.0%	0.0%	0.0%	0.0%	0.0%	0.0%	0.0%	0.0%	0.0%	100.0%	100.0%	0.0%	0.0%	0.0%	0.0%	0.0%	0.0%	0.0%
Bicycles on Crosswalk	0	0	0	0	0	0	0	0	0	0	0	0	0	0	0	0	0	0	0
% Bicycles on Crosswalk	0.0%	0.0%	0.0%	0.0%	0.0%	0.0%	0.0%	0.0%	0.0%	0.0%	0.0%	0.0%	0.0%	0.0%	0.0%	0.0%	0.0%	0.0%	0.0%

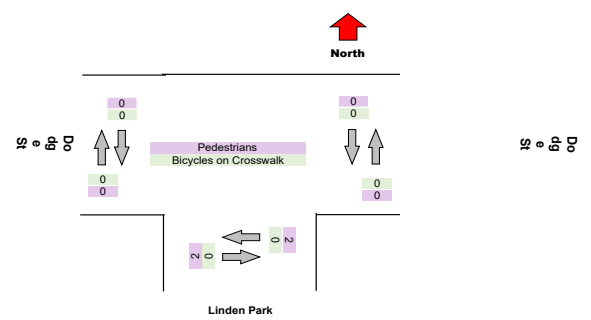
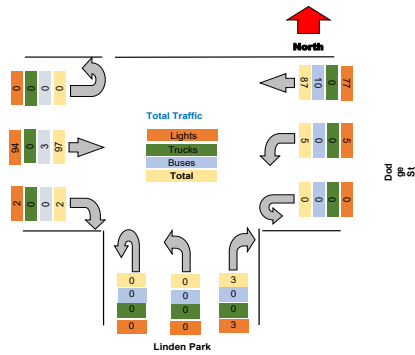

Turning Movement Peak Hour Data (PM)  
4:30:00 PM

Leg Direction	Dodge St Westbound						Linden Park Northbound						Dodge St Eastbound						Total
	Thru	Left	U-Turn	App Total	Peds CW	Peds CCW	Right	Left	U-Turn	App Total	Peds CW	Peds CCW	Right	Thru	U-Turn	App Total	Peds CW	Peds CCW	
4:30:00 PM	29	1	0	30	0	0	0	0	0	0	0	1	4	36	0	40	0	0	70
4:45:00 PM	29	4	0	33	0	0	0	0	0	0	1	2	24	0	26	0	0	59	
5:00:00 PM	24	2	0	26	0	0	2	1	0	3	0	0	2	26	0	28	0	0	57
5:15:00 PM	25	0	0	25	0	0	1	0	0	1	0	0	0	19	0	19	0	0	45
<b>Grand Total</b>	<b>107</b>	<b>7</b>	<b>0</b>	<b>114</b>	<b>0</b>	<b>0</b>	<b>3</b>	<b>1</b>	<b>0</b>	<b>4</b>	<b>0</b>	<b>2</b>	<b>8</b>	<b>105</b>	<b>0</b>	<b>113</b>	<b>0</b>	<b>0</b>	<b>231</b>
% Approach	93.9%	6.1%	0.0%	0.0%	0.0%	0.0%	14.2%	0.0%	0.0%	0.0%	0.0%	0.0%	45.1%	41.7%	0.0%	0.0%	0.0%	0.0%	
% Total	46.3%	3.0%	0.0%	49.4%	0.0%	0.0%	1.3%	0.4%	0.0%	1.7%	0.0%	0.0%	3.5%	45.5%	0.0%	48.9%	0.0%	0.0%	
PHF	0.922	0.438	0.000	0.864	0.000	0.000	0.375	0.250	0.000	0.333	0.000	0.000	0.500	0.729	0.000	0.706	0.000	0.000	0.825
Lights	103	6	0	109	0	0	3	1	0	4	0	0	6	103	0	109	0	0	222
% Lights	96.3%	85.7%	0.0%	95.6%	0.0%	0.0%	100.0%	100.0%	0.0%	100.0%	0.0%	0.0%	75.0%	98.1%	0.0%	96.5%	0.0%	0.0%	96.1%
Trucks	0	0	0	0	0	0	0	0	0	0	0	0	0	0	0	0	0	0	0
% Trucks	0.0%	0.0%	0.0%	0.0%	0.0%	0.0%	0.0%	0.0%	0.0%	0.0%	0.0%	0.0%	0.0%	0.0%	0.0%	0.0%	0.0%	0.0%	0.0%
Buses	4	1	0	5	0	0	0	0	0	0	0	0	2	2	0	4	0	0	9
% Buses	3.7%	14.3%	0.0%	0.0%	0.0%	0.0%	0.0%	0.0%	0.0%	0.0%	0.0%	0.0%	25.0%	1.9%	0.0%	0.0%	0.0%	0.0%	3.9%
Pedestrians	0	0	0	0	0	0	0	0	0	0	2	0	0	0	0	0	0	0	0
% Pedestrians	0.0%	0.0%	0.0%	0.0%	0.0%	0.0%	0.0%	0.0%	0.0%	0.0%	100.0%	0.0%	0.0%	0.0%	0.0%	0.0%	0.0%	0.0%	0.0%
Bicycles on Crosswalk	0	0	0	0	0	0	0	0	0	0	0	0	0	0	0	0	0	0	0
% Bicycles on Crosswalk	0.0%	0.0%	0.0%	0.0%	0.0%	0.0%	0.0%	0.0%	0.0%	0.0%	0.0%	0.0%	0.0%	0.0%	0.0%	0.0%	0.0%	0.0%	0.0%

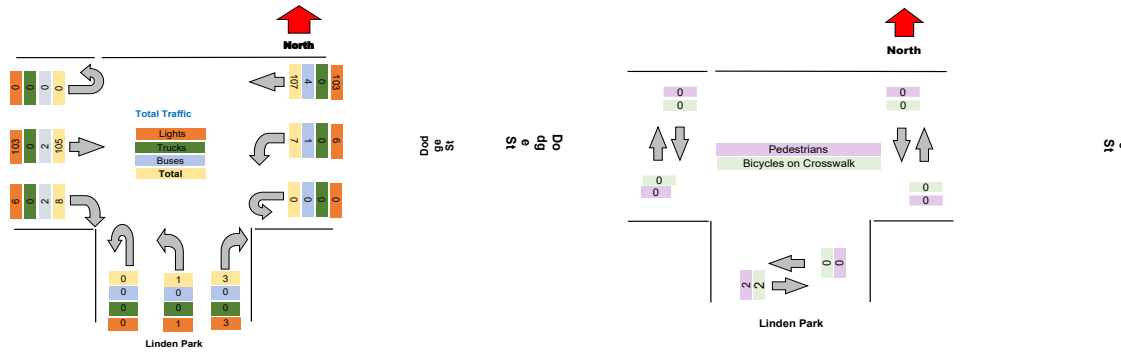





Turning Movement Data Plot

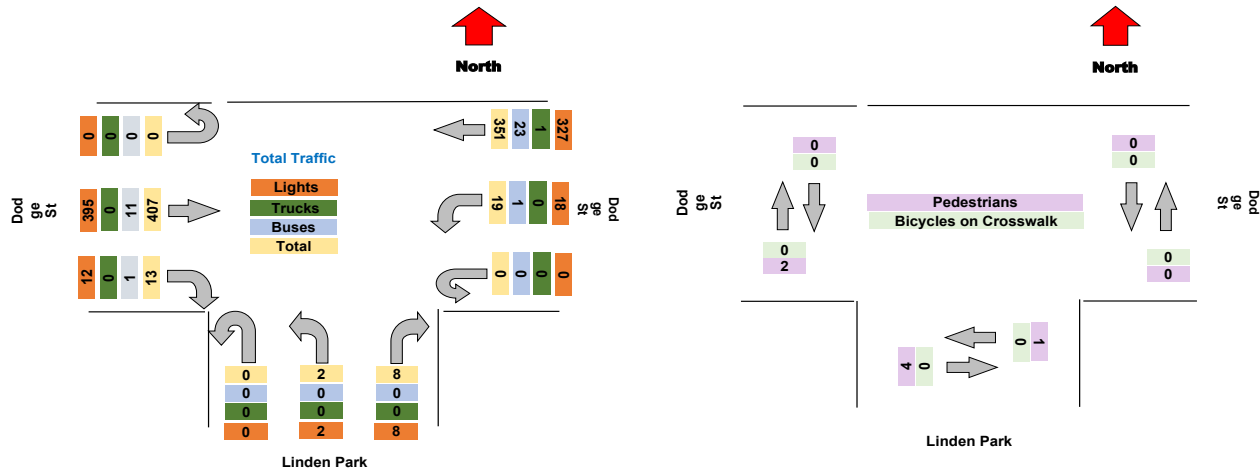

Turning Movement Peak Hour Data (AM)  
7:30:00 AM

Leg Direction	Dodge St Westbound						Linden Park Northbound						Dodge St Eastbound						Total
	Thru	Left	U-Turn	App Total	Peds CW	Peds CCW	Right	Left	U-Turn	App Total	Peds CW	Peds CCW	Right	Thru	U-Turn	App Total	Peds CW	Peds CCW	
7:30:00 AM	16	1	0	17	0	0	0	0	0	0	0	0	0	15	0	15	0	0	32
7:45:00 AM	21	2	0	23	0	0	0	0	0	0	1	0	24	0	25	1	0	0	48
8:00:00 AM	21	0	0	21	0	0	1	1	0	2	0	0	1	20	0	21	0	0	44
8:15:00 AM	22	2	0	24	0	0	0	0	0	0	0	0	28	0	28	0	0	0	52
<b>Grand Total</b>	<b>80</b>	<b>5</b>	<b>0</b>	<b>85</b>	<b>0</b>	<b>0</b>	<b>1</b>	<b>1</b>	<b>0</b>	<b>2</b>	<b>0</b>	<b>1</b>	<b>1</b>	<b>87</b>	<b>0</b>	<b>89</b>	<b>1</b>	<b>0</b>	<b>176</b>
% Approach	94.1%	5.9%	0.0%	0.0%	0.0%	0.0%	14.2%	0.0%	0.0%	0.0%	0.0%	0.0%	45.1%	41.7%	0.0%	0.0%	0.0%	0.0%	
% Total	45.5%	2.8%	0.0%	48.3%	0.0%	0.0%	0.6%	0.6%	0.0%	1.1%	0.0%	0.0%	0.6%	49.4%	0.0%	50.6%	0.0%	0.0%	
PHF	0.909	0.625	0.000	0.885	0.000	0.000	0.250	0.250	0.000	0.250	0.000	0.000	0.250	0.777	0.000	0.795	0.000	0.000	0.846
Lights	72	5	0	77	0	0	1	1	0	2	0	0	1	84	0	85	0	0	164
% Lights	90.0%	100.0%	0.0%	90.6%	0.0%	0.0%	100.0%	100.0%	0.0%	100.0%	0.0%	0.0%	100.0%	96.6%	0.0%	95.5%	0.0%	0.0%	93.2%
Trucks	0	0	0	0	0	0	0	0	0	0	0	0	0	0	0	0	0	0	0
% Trucks	0.0%	0.0%	0.0%	0.0%	0.0%	0.0%	0.0%	0.0%	0.0%	0.0%	0.0%	0.0%	0.0%	0.0%	0.0%	0.0%	0.0%	0.0%	0.0%
Buses	8	0	0	8	0	0	0	0	0	0	0	0	0	3	0	3	0	0	11
% Buses	10.0%	0.0%	0.0%	0.0%	0.0%	0.0%	0.0%	0.0%	0.0%	0.0%	0.0%	0.0%	0.0%	3.4%	0.0%	0.0%	0.0%	0.0%	6.3%
Pedestrians	0	0	0	0	0	0	0	0	0	0	0	1	0	0	0	1	0	0	0
% Pedestrians	0.0%	0.0%	0.0%	0.0%	0.0%	0.0%	0.0%	0.0%	0.0%	0.0%	100.0%	0.0%	0.0%	0.0%	0.0%	0.0%	100.0%	0.0%	0.0%
Bicycles on Crosswalk	0	0	0	0	0	0	0	0	0	0	0	0	0	0	0	0	0	0	0
% Bicycles on Crosswalk	0.0%	0.0%	0.0%	0.0%	0.0%	0.0%	0.0%	0.0%	0.0%	0.0%	0.0%	0.0%	0.0%	0.0%	0.0%	0.0%	0.0%	0.0%	0.0%

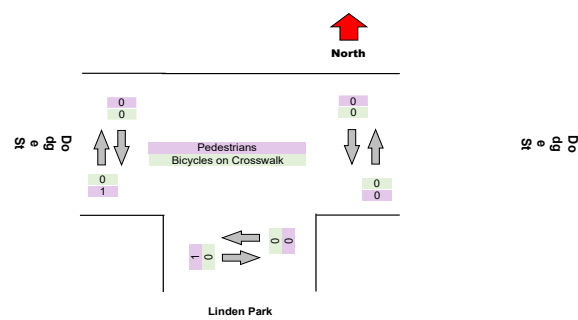
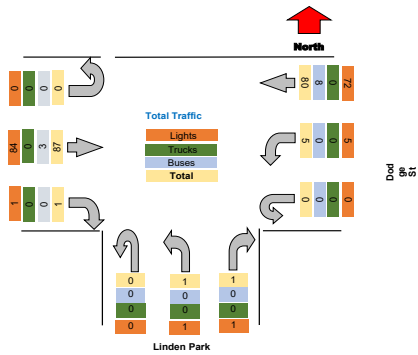

Turning Movement Peak Hour Data (PM)

4:30:00 PM

Leg Direction	Dodge St Westbound						Linden Park Northbound						Dodge St Eastbound						Total
	Thru	Left	U-Turn	App Total	Peds CW	Peds CCW	Right	Left	U-Turn	App Total	Peds CW	Peds CCW	Right	Thru	U-Turn	App Total	Peds CW	Peds CCW	
4:30:00 PM	27	0	0	27	0	0	0	0	0	0	0	0	1	37	0	38	1	0	65
4:45:00 PM	33	4	0	37	0	0	1	0	1	0	1	1	4	36	0	40	0	0	78
5:00:00 PM	22	1	0	23	0	0	0	0	0	0	0	1	31	0	32	0	0	55	
5:15:00 PM	33	0	0	33	0	0	1	0	1	0	0	0	0	37	0	37	0	0	71
<b>Grand Total</b>	<b>115</b>	<b>5</b>	<b>0</b>	<b>120</b>	<b>0</b>	<b>0</b>	<b>2</b>	<b>0</b>	<b>2</b>	<b>0</b>	<b>1</b>	<b>6</b>	<b>141</b>	<b>0</b>	<b>147</b>	<b>1</b>	<b>0</b>	<b>269</b>	
% Approach	95.8%	4.2%	0.0%	0.0%	0.0%	0.0%	14.2%	0.0%	0.0%	0.0%	0.0%	45.1%	41.7%	0.0%	0.0%	0.0%	0.0%	0.0%	
% Total	42.8%	1.9%	0.0%	44.6%	0.0%	0.0%	0.7%	0.0%	0.7%	0.0%	0.0%	2.2%	52.4%	0.0%	54.6%	0.0%	0.0%		
PHF	0.871	0.313	0.000	0.811	0.000	0.000	0.500	0.000	0.500	0.000	0.000	0.375	0.953	0.000	0.919	0.000	0.000		
Lights	106	5	0	111	0	0	2	0	2	0	0	5	137	0	142	0	0	255	
% Lights	92.2%	100.0%	0.0%	92.5%	0.0%	0.0%	100.0%	0.0%	100.0%	0.0%	0.0%	83.3%	97.2%	0.0%	96.6%	0.0%	0.0%	94.8%	
Trucks	0	0	0	0	0	0	0	0	0	0	0	0	0	0	0	0	0	0	0
% Trucks	0.0%	0.0%	0.0%	0.0%	0.0%	0.0%	0.0%	0.0%	0.0%	0.0%	0.0%	0.0%	0.0%	0.0%	0.0%	0.0%	0.0%	0.0%	
Buses	9	0	0	9	0	0	0	0	0	0	0	1	3	0	4	0	0	13	
% Buses	7.8%	0.0%	0.0%	0.0%	0.0%	0.0%	0.0%	0.0%	0.0%	0.0%	0.0%	16.7%	2.1%	0.0%	0.0%	0.0%	0.0%	4.8%	
Pedestrians	0	0	0	0	0	0	0	0	0	0	1	0	0	0	1	0	0	0	
% Pedestrians	0.0%	0.0%	0.0%	0.0%	0.0%	0.0%	0.0%	0.0%	0.0%	0.0%	100.0%	0.0%	0.0%	0.0%	0.0%	100.0%	0.0%	0.0%	
Bicycles on Crosswalk	0	0	0	0	0	0	0	0	0	0	0	0	0	0	0	0	0	0	0
% Bicycles on Crosswalk	0.0%	0.0%	0.0%	0.0%	0.0%	0.0%	0.0%	0.0%	0.0%	0.0%	0.0%	0.0%	0.0%	0.0%	0.0%	0.0%	0.0%	0.0%	

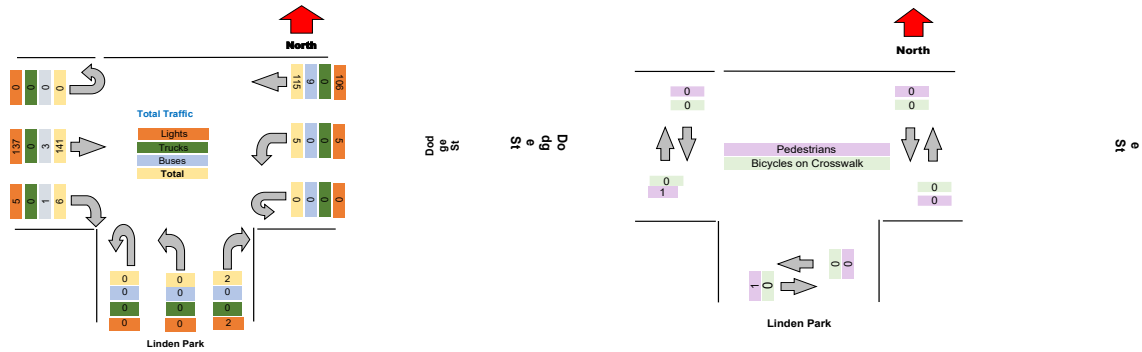



Turning Movement Data Plot

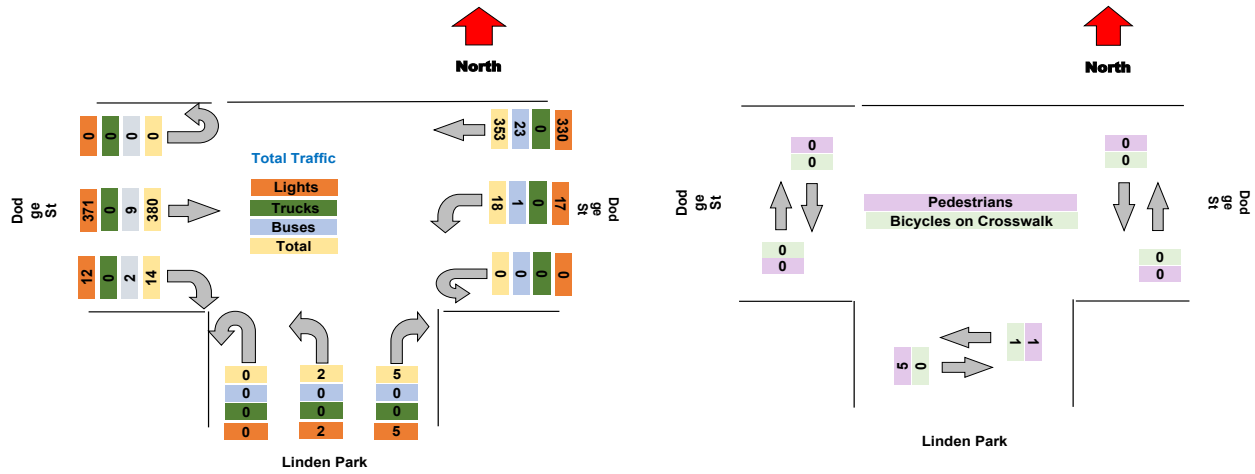

Turning Movement Peak Hour Data (AM)  
7:30:00 AM

Leg Direction	Dodge St Westbound						Linden Park Northbound						Dodge St Eastbound						Total
	Thru	Left	U-Turn	App Total	Peds CW	Peds CCW	Right	Left	U-Turn	App Total	Peds CW	Peds CCW	Right	Thru	U-Turn	App Total	Peds CW	Peds CCW	
7:30:00 AM	11	2	0	13	0	0	0	0	0	0	0	0	0	13	0	13	0	0	26
7:45:00 AM	21	0	0	21	0	0	1	0	0	1	0	1	0	25	0	26	0	0	48
8:00:00 AM	23	0	0	23	0	0	3	0	0	3	0	0	0	18	0	18	0	0	44
8:15:00 AM	12	0	0	12	0	0	0	0	0	1	0	0	0	15	0	16	0	0	28
<b>Grand Total</b>	67	2	0	69	0	0	4	0	0	4	1	1	0	71	0	73	0	0	146
% Approach	97.1%	2.9%	0.0%	0.0%	0.0%	0.0%	14.2%	0.0%	0.0%	0.0%	0.0%	0.0%	45.1%	41.7%	0.0%	0.0%	0.0%	0.0%	
% Total	45.9%	1.4%	0.0%	47.3%	0.0%	0.0%	2.7%	0.0%	0.0%	2.7%	0.0%	0.0%	0.0%	48.6%	0.0%	50.0%	0.0%	0.0%	
PHF	0.728	0.250	0.000	0.750	0.000	0.000	0.333	0.000	0.000	0.333	0.000	0.000	0.000	0.710	0.000	0.702	0.000	0.000	0.760
Lights	57	2	0	59	0	0	4	0	0	4	0	0	0	69	0	69	0	0	132
% Lights	85.1%	100.0%	0.0%	85.5%	0.0%	0.0%	100.0%	0.0%	0.0%	100.0%	0.0%	0.0%	0.0%	97.2%	0.0%	94.5%	0.0%	0.0%	90.4%
Trucks	0	0	0	0	0	0	0	0	0	0	0	0	0	0	0	0	0	0	0
% Trucks	0.0%	0.0%	0.0%	0.0%	0.0%	0.0%	0.0%	0.0%	0.0%	0.0%	0.0%	0.0%	0.0%	0.0%	0.0%	0.0%	0.0%	0.0%	0.0%
Buses	10	0	0	10	0	0	0	0	0	0	0	0	0	2	0	2	0	0	12
% Buses	14.9%	0.0%	0.0%	0.0%	0.0%	0.0%	0.0%	0.0%	0.0%	0.0%	0.0%	0.0%	0.0%	2.8%	0.0%	0.0%	0.0%	0.0%	8.2%
Pedestrians	0	0	0	0	0	0	0	0	0	0	0	0	0	0	0	0	0	0	0
% Pedestrians	0.0%	0.0%	0.0%	0.0%	0.0%	0.0%	0.0%	0.0%	0.0%	0.0%	100.0%	0.0%	0.0%	0.0%	0.0%	0.0%	0.0%	0.0%	0.0%
Bicycles on Crosswalk	0	0	0	0	0	0	0	0	0	1	0	0	0	0	0	0	0	0	0
% Bicycles on Crosswalk	0.0%	0.0%	0.0%	0.0%	0.0%	0.0%	0.0%	0.0%	0.0%	0.0%	100.0%	0.0%	0.0%	0.0%	0.0%	0.0%	0.0%	0.0%	0.0%

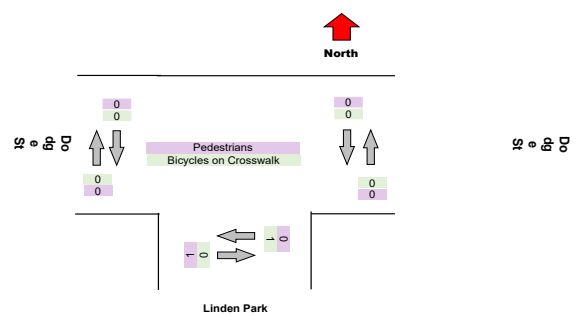
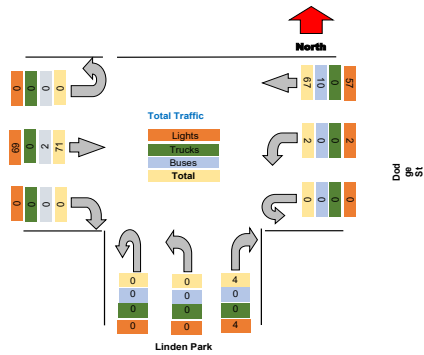

Turning Movement Peak Hour Data (PM)  
4:30:00 PM

Leg Direction	Dodge St Westbound						Linden Park Northbound						Dodge St Eastbound						Total
	Thru	Left	U-Turn	App Total	Peds CW	Peds CCW	Right	Left	U-Turn	App Total	Peds CW	Peds CCW	Right	Thru	U-Turn	App Total	Peds CW	Peds CCW	
4:30:00 PM	38	2	0	40	0	0	0	0	0	0	0	0	1	35	0	36	0	0	76
4:45:00 PM	33	4	0	37	0	0	0	0	0	0	0	0	1	32	0	33	0	0	70
5:00:00 PM	24	2	0	26	0	0	0	0	0	0	2	2	30	0	32	0	0	58	
5:15:00 PM	31	2	0	33	0	0	0	1	1	0	0	2	34	0	36	0	0	70	
<b>Grand Total</b>	<b>126</b>	<b>10</b>	<b>0</b>	<b>136</b>	<b>0</b>	<b>0</b>	<b>0</b>	<b>1</b>	<b>1</b>	<b>0</b>	<b>2</b>	<b>6</b>	<b>131</b>	<b>0</b>	<b>137</b>	<b>0</b>	<b>0</b>	<b>274</b>	
% Approach	92.6%	7.4%	0.0%	0.0%	0.0%	0.0%	14.2%	0.0%	0.0%	0.0%	0.0%	45.1%	41.7%	0.0%	0.0%	0.0%	0.0%	0.0%	
% Total	46.0%	3.6%	0.0%	49.6%	0.0%	0.0%	0.0%	0.4%	0.0%	0.4%	0.0%	2.2%	47.8%	0.0%	50.0%	0.0%	0.0%	0.0%	
PHF	0.829	0.625	0.000	0.850	0.000	0.000	0.000	0.250	0.000	0.250	0.000	0.750	0.936	0.000	0.951	0.000	0.000	0.901	
Lights	117	9	0	126	0	0	0	1	0	1	0	4	129	0	133	0	0	260	
% Lights	92.9%	90.0%	0.0%	92.6%	0.0%	0.0%	0.0%	100.0%	0.0%	100.0%	0.0%	66.7%	98.5%	0.0%	97.1%	0.0%	0.0%	94.9%	
Trucks	0	0	0	0	0	0	0	0	0	0	0	0	0	0	0	0	0	0	
% Trucks	0.0%	0.0%	0.0%	0.0%	0.0%	0.0%	0.0%	0.0%	0.0%	0.0%	0.0%	0.0%	0.0%	0.0%	0.0%	0.0%	0.0%	0.0%	
Buses	9	1	0	10	0	0	0	0	0	0	0	2	2	0	4	0	0	14	
% Buses	7.1%	10.0%	0.0%	0.0%	0.0%	0.0%	0.0%	0.0%	0.0%	0.0%	0.0%	33.3%	1.5%	0.0%	0.0%	0.0%	0.0%	5.1%	
Pedestrians	0	0	0	0	0	0	0	0	0	0	2	0	0	0	0	0	0	0	
% Pedestrians	0.0%	0.0%	0.0%	0.0%	0.0%	0.0%	0.0%	0.0%	0.0%	0.0%	100.0%	0.0%	0.0%	0.0%	0.0%	0.0%	0.0%	0.0%	
Bicycles on Crosswalk	0	0	0	0	0	0	0	0	0	0	0	0	0	0	0	0	0	0	
% Bicycles on Crosswalk	0.0%	0.0%	0.0%	0.0%	0.0%	0.0%	0.0%	0.0%	0.0%	0.0%	0.0%	0.0%	0.0%	0.0%	0.0%	0.0%	0.0%	0.0%	

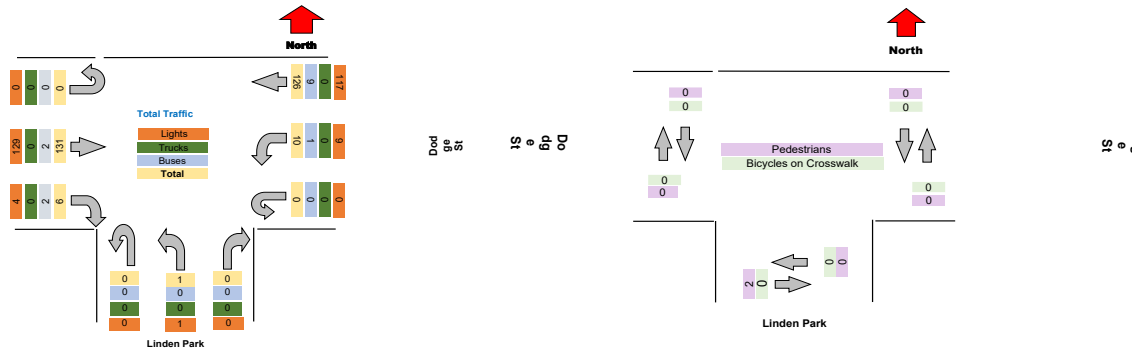





Turning Movement Data Plot

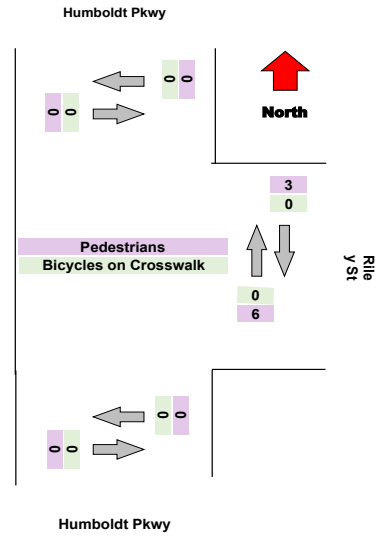
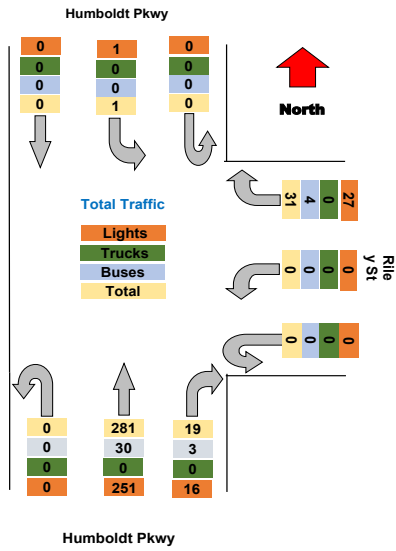

**Turning Movement Peak Hour Data (AM)**  
 7:30:00 AM

Leg	Humboldt Pkwy						Riley St						Humboldt Pkwy						Total
	Southbound						Westbound						Northbound						
Direction	Thru	Left	U-Turn	App	Total	Peds CW/Peds CCW	Right	Left	U-Turn	App	Total	Peds CW/Peds CCW	Right	Thru	U-Turn	App	Total	Peds CW/Peds CCW	
7:30:00 AM	0	0	0	0	0	0	3	0	0	3	1	1	3	21	0	26	0	0	29
7:45:00 AM	0	0	0	0	0	0	1	0	0	1	0	0	0	19	0	19	0	0	20
8:00:00 AM	0	0	0	0	0	0	0	0	0	0	0	0	1	15	0	16	0	0	16
8:15:00 AM	0	1	0	1	0	0	3	0	0	3	0	0	1	12	0	13	0	0	17
<b>Grand Total</b>	<b>0</b>	<b>1</b>	<b>0</b>	<b>1</b>	<b>0</b>	<b>0</b>	<b>7</b>	<b>0</b>	<b>0</b>	<b>7</b>	<b>1</b>	<b>1</b>	<b>5</b>	<b>67</b>	<b>0</b>	<b>74</b>	<b>0</b>	<b>0</b>	<b>82</b>
% Approach	0.0%	100.0%	0.0%	0.0%	0.0%	0.0%	14.2%	0.0%	0.0%	0.0%	0.0%	0.0%	45.1%	41.7%	0.0%	0.0%	0.0%	0.0%	0.0%
% Total	0.0%	1.2%	0.0%	1.2%	0.0%	0.0%	8.5%	0.0%	0.0%	8.5%	0.0%	0.0%	6.1%	81.7%	0.0%	90.2%	0.0%	0.0%	0.0%
PHF	0.000	0.250	0.000	0.250	0.000	0.000	0.583	0.000	0.000	0.583	0.000	0.000	0.417	0.798	0.000	0.712	0.000	0.000	0.707
Lights	0	1	0	1	0	0	5	0	0	5	0	0	4	56	0	60	0	0	66
% Lights	0.0%	100.0%	0.0%	100.0%	0.0%	0.0%	71.4%	0.0%	0.0%	71.4%	0.0%	0.0%	80.0%	83.6%	0.0%	81.1%	0.0%	0.0%	80.5%
Trucks	0	0	0	0	0	0	0	0	0	0	0	0	0	0	0	0	0	0	0
% Trucks	0.0%	0.0%	0.0%	0.0%	0.0%	0.0%	0.0%	0.0%	0.0%	0.0%	0.0%	0.0%	0.0%	0.0%	0.0%	0.0%	0.0%	0.0%	0.0%
Buses	0	0	0	0	0	0	2	0	0	2	0	0	1	11	0	12	0	0	14
% Buses	0.0%	0.0%	0.0%	0.0%	0.0%	0.0%	28.6%	0.0%	0.0%	28.6%	0.0%	0.0%	20.0%	16.4%	0.0%	0.0%	0.0%	0.0%	17.1%
Pedestrians	0	0	0	0	0	0	0	0	0	0	1	1	0	0	0	0	0	0	0
% Pedestrians	0.0%	0.0%	0.0%	0.0%	0.0%	0.0%	0.0%	0.0%	0.0%	0.0%	100.0%	100.0%	0.0%	0.0%	0.0%	0.0%	0.0%	0.0%	0.0%
Bicycles on Crosswalk	0	0	0	0	0	0	0	0	0	0	0	0	0	0	0	0	0	0	0
% Bicycles on Crosswalk	0.0%	0.0%	0.0%	0.0%	0.0%	0.0%	0.0%	0.0%	0.0%	0.0%	0.0%	0.0%	0.0%	0.0%	0.0%	0.0%	0.0%	0.0%	0.0%

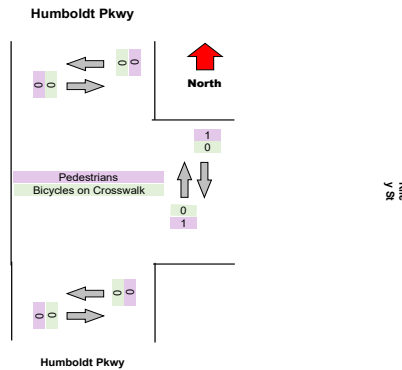
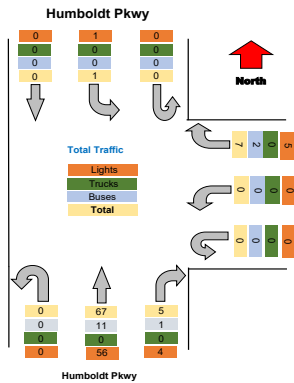

Turning Movement Peak Hour Data (PM)  
 4:30:00 PM

Leg Direction	Humboldt Pkwy						Riley St						Humboldt Pkwy						Total
	Southbound			Westbound			Northbound			Northbound									
Start Time	Thru	Left	U-Turn	App Total	Peds CW	Peds CCW	Right	Left	U-Turn	App Total	Peds CW	Peds CCW	Right	Thru	U-Turn	App Total	Peds CW	Peds CCW	
4:30:00 PM	0	0	0	0	0	0	1	0	0	1	1	0	0	24	0	24	0	0	
4:45:00 PM	0	0	0	0	0	0	3	0	0	3	0	1	3	25	0	28	0	0	
5:00:00 PM	0	0	0	0	0	0	0	0	0	0	1	0	0	21	0	21	0	0	
5:15:00 PM	0	0	0	0	0	0	5	0	0	5	0	1	0	19	0	19	0	0	
<b>Grand Total</b>	0	0	0	0	0	0	9	0	0	9	2	2	3	89	0	92	0	0	
% Approach	#####	#DIV/0!	#####	0.0%	0.0%	0.0%	14.2%	0.0%	0.0%	0.0%	0.0%	0.0%	45.1%	41.7%	0.0%	0.0%	0.0%	0.0%	
% Total	0.0%	0.0%	0.0%	0.0%	0.0%	0.0%	8.9%	0.0%	0.0%	8.9%	0.0%	0.0%	3.0%	88.1%	0.0%	91.1%	0.0%	0.0%	
PHF	0.000	0.000	0.000	0.000	0.000	0.000	0.450	0.000	0.000	0.450	0.000	0.000	0.250	0.890	0.000	0.821	0.000	0.000	
Lights	0	0	0	0	0	0	9	0	0	9	0	0	2	85	0	87	0	0	
% Lights	0.0%	0.0%	0.0%	0.0%	0.0%	0.0%	100.0%	0.0%	0.0%	100.0%	0.0%	0.0%	66.7%	95.5%	0.0%	94.6%	0.0%	0.0%	
Trucks	0	0	0	0	0	0	0	0	0	0	0	0	0	0	0	0	0	0	
% Trucks	0.0%	0.0%	0.0%	0.0%	0.0%	0.0%	0.0%	0.0%	0.0%	0.0%	0.0%	0.0%	0.0%	0.0%	0.0%	0.0%	0.0%	0.0%	
Buses	0	0	0	0	0	0	0	0	0	0	0	0	0	4	0	5	0	0	
% Buses	0.0%	0.0%	0.0%	0.0%	0.0%	0.0%	0.0%	0.0%	0.0%	0.0%	0.0%	0.0%	33.3%	4.5%	0.0%	0.0%	0.0%	0.0%	
Pedestrians	0	0	0	0	0	0	0	0	0	0	2	2	0	0	0	0	0	0	
% Pedestrians	0.0%	0.0%	0.0%	0.0%	0.0%	0.0%	0.0%	0.0%	0.0%	0.0%	100.0%	100.0%	0.0%	0.0%	0.0%	0.0%	0.0%	0.0%	
Bicycles on Crosswalk	0	0	0	0	0	0	0	0	0	0	0	0	0	0	0	0	0	0	
% Bicycles on Crosswalk	0.0%	0.0%	0.0%	0.0%	0.0%	0.0%	0.0%	0.0%	0.0%	0.0%	0.0%	0.0%	0.0%	0.0%	0.0%	0.0%	0.0%	0.0%	

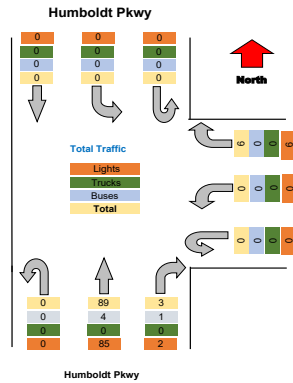

Riley St

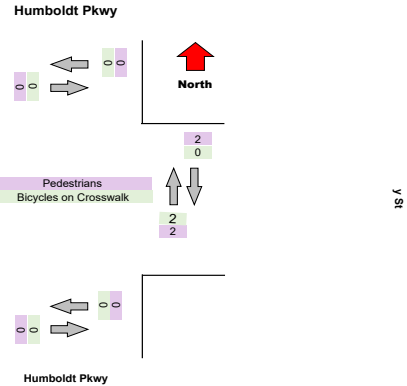

Riley St

Intersection: Elm St Pine St  
 Location: Kennett Square, PA  
 Site: 01  
 Survey Date: Wednesday, 04-28-2021  
 GPS: 42.948550, -72.790034



Project	Labella
Project Code	Labella
Site Name	G
Legs and Movements	All Processed Legs & Movements
Bin Size	15 minutes
Survey Date	2021-10-27, Wednesday
Location	G
Latitude and Longitude	42.909346, -78.843052

	Start	End	PHF
Forced Peak AM	2021/10/27 07:30:00	2021/10/27 08:30:00	0.917
Forced Peak PM	2021/10/27 16:30:00	2021/10/27 17:30:00	0.833
AM Peak	2021/10/27 07:30:00	2021/10/27 08:30:00	0.917
PM Peak	2021/10/27 16:30:00	2021/10/27 17:30:00	0.833

Turning Movement Data

Leg Direction	Humboldt Pkwy Southbound						Riley St Westbound						Humboldt Pkwy Northbound						Total
	Thru	Left	U-Turn	App Total	Peds CW	Peds CCW	Right	Left	U-Turn	App Total	Peds CW	Peds CCW	Right	Thru	U-Turn	App Total	Peds CW	Peds CCW	
Start Time																			
6:30:00 AM	0	0	0	0	0	0	1	0	0	1	0	0	0	8	0	8	0	0	
6:45:00 AM	0	0	0	0	0	0	1	0	0	1	0	0	1	7	0	8	0	0	
<b>Hourly Total</b>	<b>0</b>	<b>0</b>	<b>0</b>	<b>0</b>	<b>0</b>	<b>0</b>	<b>2</b>	<b>0</b>	<b>0</b>	<b>2</b>	<b>0</b>	<b>0</b>	<b>1</b>	<b>15</b>	<b>0</b>	<b>16</b>	<b>0</b>	<b>0</b>	
7:00:00 AM	0	0	0	0	0	0	3	0	0	3	0	0	1	13	0	14	0	0	
7:15:00 AM	0	0	0	0	0	0	2	0	0	2	0	0	0	17	0	17	0	0	
7:30:00 AM	0	0	0	0	0	0	1	0	0	1	0	0	3	17	0	20	0	0	
7:45:00 AM	0	0	0	0	0	0	2	0	0	2	1	1	0	15	0	17	0	0	
<b>Hourly Total</b>	<b>0</b>	<b>0</b>	<b>0</b>	<b>0</b>	<b>0</b>	<b>0</b>	<b>8</b>	<b>0</b>	<b>0</b>	<b>8</b>	<b>1</b>	<b>1</b>	<b>4</b>	<b>62</b>	<b>0</b>	<b>68</b>	<b>0</b>	<b>0</b>	
8:00:00 AM	0	0	0	0	0	0	2	0	0	2	0	0	1	18	0	19	0	0	
8:15:00 AM	0	0	0	0	0	0	2	0	0	2	0	0	1	13	0	14	0	0	
<b>Hourly Total</b>	<b>0</b>	<b>0</b>	<b>0</b>	<b>0</b>	<b>0</b>	<b>0</b>	<b>4</b>	<b>0</b>	<b>0</b>	<b>4</b>	<b>0</b>	<b>0</b>	<b>2</b>	<b>31</b>	<b>0</b>	<b>33</b>	<b>0</b>	<b>0</b>	
4:00:00 PM	0	0	0	0	0	0	3	0	0	3	0	0	4	20	0	24	0	0	
4:15:00 PM	0	0	0	0	0	0	2	0	0	2	0	1	2	36	0	38	0	0	
4:30:00 PM	0	0	0	0	0	0	3	0	0	3	0	0	1	16	0	17	0	0	
4:45:00 PM	0	0	0	0	0	0	3	0	0	3	0	0	4	23	0	27	0	0	
<b>Hourly Total</b>	<b>0</b>	<b>0</b>	<b>0</b>	<b>0</b>	<b>0</b>	<b>0</b>	<b>11</b>	<b>0</b>	<b>0</b>	<b>11</b>	<b>0</b>	<b>1</b>	<b>11</b>	<b>95</b>	<b>0</b>	<b>106</b>	<b>0</b>	<b>0</b>	
5:00:00 PM	0	0	0	0	0	0	1	0	0	1	0	0	1	21	0	22	0	0	
5:15:00 PM	0	0	0	0	0	0	2	0	0	2	1	4	2	23	0	25	0	0	
5:30:00 PM	0	0	0	0	0	0	3	0	0	3	3	0	3	21	0	24	0	0	
5:45:00 PM	0	0	0	0	0	0	3	0	0	3	0	1	3	21	0	24	0	0	
<b>Hourly Total</b>	<b>0</b>	<b>0</b>	<b>0</b>	<b>0</b>	<b>0</b>	<b>0</b>	<b>9</b>	<b>0</b>	<b>0</b>	<b>9</b>	<b>4</b>	<b>5</b>	<b>9</b>	<b>86</b>	<b>0</b>	<b>95</b>	<b>0</b>	<b>0</b>	
<b>Grand Total</b>	<b>0</b>	<b>0</b>	<b>0</b>	<b>0</b>	<b>0</b>	<b>0</b>	<b>34</b>	<b>0</b>	<b>0</b>	<b>34</b>	<b>5</b>	<b>7</b>	<b>27</b>	<b>289</b>	<b>0</b>	<b>318</b>	<b>0</b>	<b>0</b>	
% Approach	0.0%	0.0%	0.0%	0.0%	0.0%	0.0%	100.0%	0.0%	0.0%	0.0%	0.0%	0.0%	8.5%	90.9%	0.0%	0.0%	0.0%	0.0%	
% Total	0.0%	0.0%	0.0%	0.0%	0.0%	0.0%	9.7%	0.0%	0.0%	9.7%	0.0%	0.0%	7.7%	82.1%	0.0%	90.3%	0.0%	0.0%	
Lights	0	0	0	0	0	0	30	0	0	30	0	0	23	255	0	278	0	0	
% Lights	0.0%	0.0%	0.0%	0.0%	0.0%	0.0%	88.2%	0.0%	0.0%	88.2%	0.0%	0.0%	85.2%	88.2%	0.0%	87.4%	0.0%	0.0%	
Trucks	0	0	0	0	0	0	0	0	0	0	0	0	0	0	0	0	0	0	
% Trucks	0.0%	0.0%	0.0%	0.0%	0.0%	0.0%	0.0%	0.0%	0.0%	0.0%	0.0%	0.0%	0.0%	0.0%	0.0%	0.0%	0.0%	0.0%	
Buses	0	0	0	0	0	0	4	0	0	4	0	0	4	34	0	38	0	0	
% Buses	0.0%	0.0%	0.0%	0.0%	0.0%	0.0%	0.0%	0.0%	0.0%	0.0%	0.0%	0.0%	14.8%	11.8%	0.0%	0.0%	0.0%	0.0%	
Pedestrians	0	0	0	0	0	0	0	0	0	0	5	6	0	0	0	0	0	0	
% Pedestrians	0.0%	0.0%	0.0%	0.0%	0.0%	0.0%	0.0%	0.0%	0.0%	0.0%	100.0%	85.7%	0.0%	0.0%	0.0%	0.0%	0.0%	0.0%	
Bicycles on Crosswalk	0	0	0	0	0	0	0	0	0	0	0	1	0	0	0	0	0	0	
% Bicycles on Crosswalk	0.0%	0.0%	0.0%	0.0%	0.0%	0.0%	0.0%	0.0%	0.0%	0.0%	0.0%	14.3%	0.0%	0.0%	0.0%	0.0%	0.0%	0.0%	

Turning Movement Data Plot

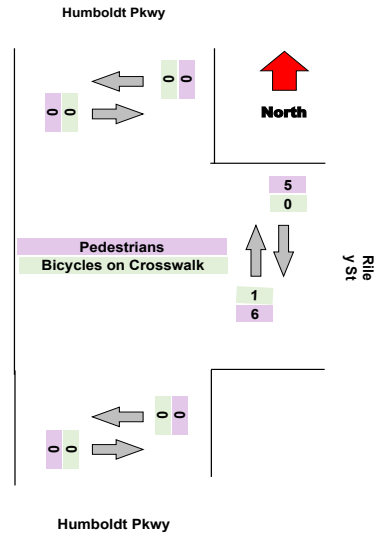
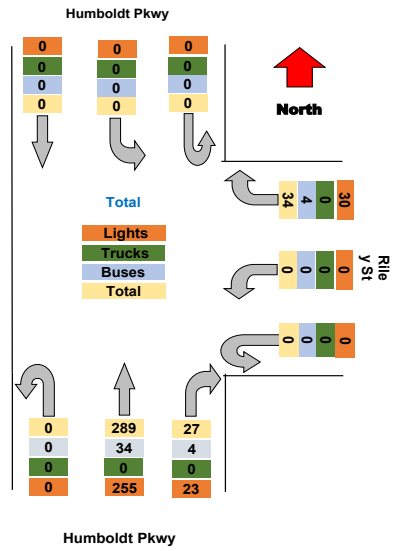

Turning Movement Peak Hour Data (AM)  
 7:30:00 AM

Leg	Humboldt Pkwy						Riley St						Humboldt Pkwy						Total
	Southbound						Westbound						Northbound						
Direction	Thru	Left	U-Turn	App Total	Peds CW	Peds CCW	Right	Left	U-Turn	App Total	Peds CW	Peds CCW	Right	Thru	U-Turn	App Total	Peds CW	Peds CCW	
7:30:00 AM	0	0	0	0	0	0	1	0	0	1	0	0	3	17	0	20	0	0	21
7:45:00 AM	0	0	0	0	0	0	2	0	0	2	1	1	0	15	0	17	0	0	19
8:00:00 AM	0	0	0	0	0	0	2	0	0	2	0	0	1	18	0	19	0	0	21
8:15:00 AM	0	0	0	0	0	0	2	0	0	2	0	0	1	13	0	14	0	0	16
<b>Grand Total</b>	<b>0</b>	<b>0</b>	<b>0</b>	<b>0</b>	<b>0</b>	<b>0</b>	<b>7</b>	<b>0</b>	<b>0</b>	<b>7</b>	<b>1</b>	<b>1</b>	<b>5</b>	<b>63</b>	<b>0</b>	<b>70</b>	<b>0</b>	<b>0</b>	<b>77</b>
% Approach	#####	#####	#####	0.0%	0.0%	0.0%	14.2%	0.0%	0.0%	0.0%	0.0%	0.0%	45.1%	41.7%	0.0%	0.0%	0.0%	0.0%	
% Total	0.0%	0.0%	0.0%	0.0%	0.0%	0.0%	9.1%	0.0%	0.0%	9.1%	0.0%	0.0%	6.5%	81.8%	0.0%	90.9%	0.0%	0.0%	
PHF	0.000	0.000	0.000	0.000	0.000	0.000	0.875	0.000	0.000	0.875	0.000	0.000	0.417	0.875	0.000	0.875	0.000	0.000	0.917
Lights	0	0	0	0	0	0	5	0	0	5	0	0	3	53	0	56	0	0	61
% Lights	0.0%	0.0%	0.0%	0.0%	0.0%	0.0%	71.4%	0.0%	0.0%	71.4%	0.0%	0.0%	60.0%	84.1%	0.0%	80.0%	0.0%	0.0%	79.2%
Trucks	0	0	0	0	0	0	0	0	0	0	0	0	0	0	0	0	0	0	0
% Trucks	0.0%	0.0%	0.0%	0.0%	0.0%	0.0%	0.0%	0.0%	0.0%	0.0%	0.0%	0.0%	0.0%	0.0%	0.0%	0.0%	0.0%	0.0%	0.0%
Buses	0	0	0	0	0	0	2	0	0	2	0	0	2	10	0	12	0	0	14
% Buses	0.0%	0.0%	0.0%	0.0%	0.0%	0.0%	28.6%	0.0%	0.0%	0.0%	0.0%	0.0%	40.0%	15.9%	0.0%	0.0%	0.0%	0.0%	18.2%
Pedestrians	0	0	0	0	0	0	0	0	0	0	1	1	0	0	0	0	0	0	0
% Pedestrians	0.0%	0.0%	0.0%	0.0%	0.0%	0.0%	0.0%	0.0%	0.0%	0.0%	100.0%	100.0%	0.0%	0.0%	0.0%	0.0%	0.0%	0.0%	0.0%
Bicycles on Crosswalk	0	0	0	0	0	0	0	0	0	0	0	0	0	0	0	0	0	0	0
% Bicycles on Crosswalk	0.0%	0.0%	0.0%	0.0%	0.0%	0.0%	0.0%	0.0%	0.0%	0.0%	0.0%	0.0%	0.0%	0.0%	0.0%	0.0%	0.0%	0.0%	0.0%

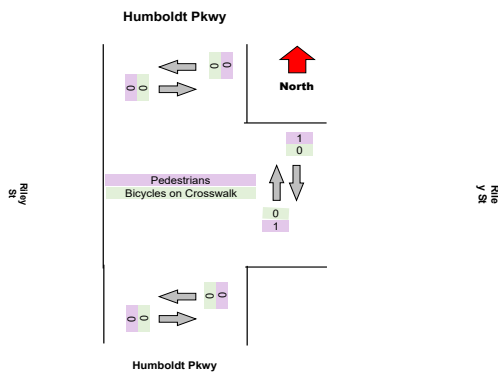
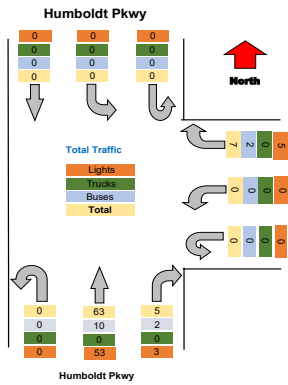

Turning Movement Peak Hour Data (PM)  
 4:30:00 PM

Leg Direction	Humboldt Pkwy Southbound						Riley St Westbound						Humboldt Pkwy Northbound						Total
	Thru	Left	U-Turn	App Total	Peds CW	Peds CCW	Right	Left	U-Turn	App Total	Peds CW	Peds CCW	Right	Thru	U-Turn	App Total	Peds CW	Peds CCW	
4:30:00 PM	0	0	0	0	0	0	3	0	0	3	0	0	1	16	0	17	0	0	20
4:45:00 PM	0	0	0	0	0	0	3	0	0	3	0	0	4	23	0	27	0	0	30
5:00:00 PM	0	0	0	0	0	0	1	0	0	1	0	0	1	21	0	22	0	0	23
5:15:00 PM	0	0	0	0	0	0	2	0	0	2	1	4	2	23	0	25	0	0	27
<b>Grand Total</b>	0	0	0	0	0	0	9	0	0	9	1	4	8	83	0	91	0	0	100
% Approach	#####	#####	#####	0.0%	0.0%	0.0%	14.2%	0.0%	0.0%	0.0%	0.0%	0.0%	45.1%	41.7%	0.0%	0.0%	0.0%	0.0%	
% Total	0.0%	0.0%	0.0%	0.0%	0.0%	0.0%	9.0%	0.0%	0.0%	9.0%	0.0%	0.0%	8.0%	83.0%	0.0%	91.0%	0.0%	0.0%	
PHF	0.000	0.000	0.000	0.000	0.000	0.000	0.750	0.000	0.000	0.750	0.000	0.000	0.500	0.902	0.000	0.843	0.000	0.000	0.833
Lights	0	0	0	0	0	0	9	0	0	9	0	0	7	79	0	86	0	0	95
% Lights	0.0%	0.0%	0.0%	0.0%	0.0%	0.0%	100.0%	0.0%	0.0%	100.0%	0.0%	0.0%	87.5%	95.2%	0.0%	94.5%	0.0%	0.0%	95.0%
Trucks	0	0	0	0	0	0	0	0	0	0	0	0	0	0	0	0	0	0	0
% Trucks	0.0%	0.0%	0.0%	0.0%	0.0%	0.0%	0.0%	0.0%	0.0%	0.0%	0.0%	0.0%	0.0%	0.0%	0.0%	0.0%	0.0%	0.0%	0.0%
Buses	0	0	0	0	0	0	0	0	0	0	0	0	1	4	0	5	0	0	5
% Buses	0.0%	0.0%	0.0%	0.0%	0.0%	0.0%	0.0%	0.0%	0.0%	0.0%	0.0%	0.0%	12.5%	4.8%	0.0%	0.0%	0.0%	0.0%	5.0%
Pedestrians	0	0	0	0	0	0	0	0	0	0	1	4	0	0	0	0	0	0	0
% Pedestrians	0.0%	0.0%	0.0%	0.0%	0.0%	0.0%	0.0%	0.0%	0.0%	0.0%	100.0%	100.0%	0.0%	0.0%	0.0%	0.0%	0.0%	0.0%	0.0%
Bicycles on Crosswalk	0	0	0	0	0	0	0	0	0	0	0	0	0	0	0	0	0	0	0
% Bicycles on Crosswalk	0.0%	0.0%	0.0%	0.0%	0.0%	0.0%	0.0%	0.0%	0.0%	0.0%	0.0%	0.0%	0.0%	0.0%	0.0%	0.0%	0.0%	0.0%	0.0%

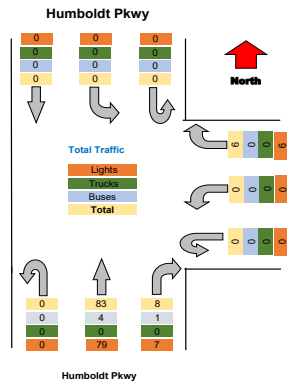

Riley St

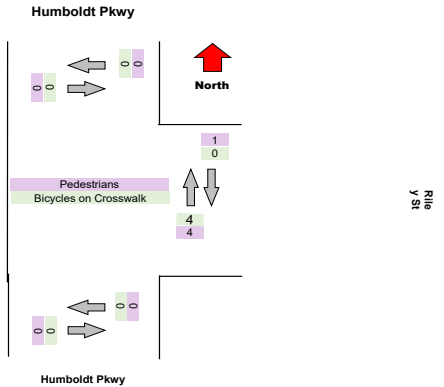

Riley St





Turning Movement Data Plot

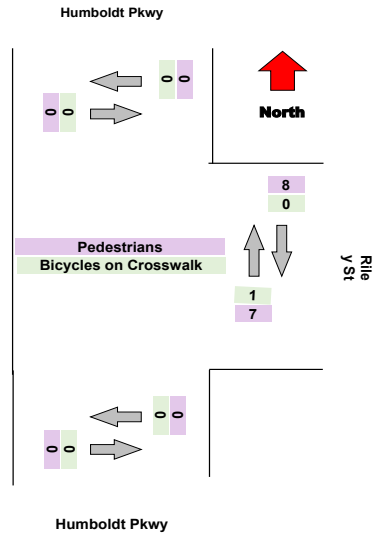
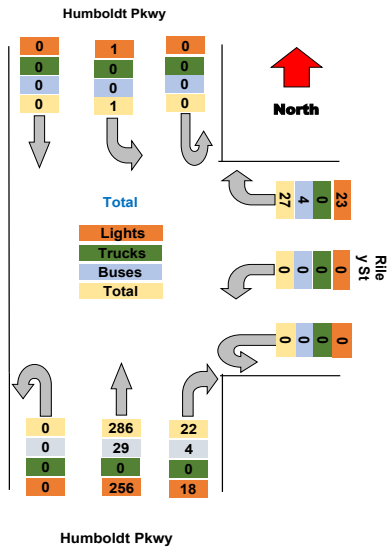

Intersection: Elm St Pine St  
 Location: Kennett Square, PA  
 Site: 01  
 Survey Date: Wednesday, 04-28-2021  
 GPS: 42.948550, -72.790034



**Turning Movement Peak Hour Data (AM)**  
 7:30:00 AM

Leg Direction	Humboldt Pkwy Southbound						Riley St Westbound						Humboldt Pkwy Northbound						Total
	Thru	Left	U-Turn	App Total	Peds CW	Peds CCW	Right	Left	U-Turn	App Total	Peds CW	Peds CCW	Right	Thru	U-Turn	App Total	Peds CW	Peds CCW	
7:30:00 AM	0	0	0	0	0	0	1	0	0	1	0	0	1	13	0	14	0	0	15
7:45:00 AM	0	0	0	0	0	0	1	0	0	1	1	1	1	27	0	30	0	0	31
8:00:00 AM	0	1	0	1	0	0	1	0	0	1	0	0	2	24	0	26	0	0	28
8:15:00 AM	0	0	0	0	0	0	0	0	0	0	0	0	1	16	0	17	0	0	17
<b>Grand Total</b>	<b>0</b>	<b>1</b>	<b>0</b>	<b>1</b>	<b>0</b>	<b>0</b>	<b>3</b>	<b>0</b>	<b>0</b>	<b>3</b>	<b>1</b>	<b>1</b>	<b>5</b>	<b>80</b>	<b>0</b>	<b>87</b>	<b>0</b>	<b>0</b>	<b>91</b>
% Approach	0.0%	#####	0.0%	0.0%	0.0%	0.0%	14.2%	0.0%	0.0%	0.0%	0.0%	0.0%	45.1%	41.7%	0.0%	0.0%	0.0%	0.0%	
% Total	0.0%	1.1%	0.0%	1.1%	0.0%	0.0%	3.3%	0.0%	0.0%	3.3%	0.0%	0.0%	5.5%	87.9%	0.0%	95.6%	0.0%	0.0%	
PHF	0.000	0.250	0.000	0.250	0.000	0.000	0.750	0.000	0.000	0.750	0.000	0.000	0.625	0.741	0.000	0.725	0.000	0.000	0.734
Lights	0	1	0	1	0	0	2	0	0	2	0	0	3	69	0	72	0	0	75
% Lights	0.0%	#####	0.0%	100.0%	0.0%	0.0%	66.7%	0.0%	0.0%	66.7%	0.0%	0.0%	60.0%	86.3%	0.0%	82.8%	0.0%	0.0%	82.4%
Trucks	0	0	0	0	0	0	0	0	0	0	0	0	0	0	0	0	0	0	0
% Trucks	0.0%	0.0%	0.0%	0.0%	0.0%	0.0%	0.0%	0.0%	0.0%	0.0%	0.0%	0.0%	0.0%	0.0%	0.0%	0.0%	0.0%	0.0%	0.0%
Buses	0	0	0	0	0	0	1	0	0	1	0	0	2	11	0	13	0	0	14
% Buses	0.0%	0.0%	0.0%	0.0%	0.0%	0.0%	33.3%	0.0%	0.0%	0.0%	0.0%	0.0%	40.0%	13.8%	0.0%	0.0%	0.0%	0.0%	15.4%
Pedestrians	0	0	0	0	0	0	0	0	0	0	1	1	0	0	0	0	0	0	0
% Pedestrians	0.0%	0.0%	0.0%	0.0%	0.0%	0.0%	0.0%	0.0%	0.0%	0.0%	100.0%	100.0%	0.0%	0.0%	0.0%	0.0%	0.0%	0.0%	0.0%
Bicycles on Crosswalk	0	0	0	0	0	0	0	0	0	0	0	0	0	0	0	0	0	0	0
% Bicycles on Crosswalk	0.0%	0.0%	0.0%	0.0%	0.0%	0.0%	0.0%	0.0%	0.0%	0.0%	0.0%	0.0%	0.0%	0.0%	0.0%	0.0%	0.0%	0.0%	0.0%

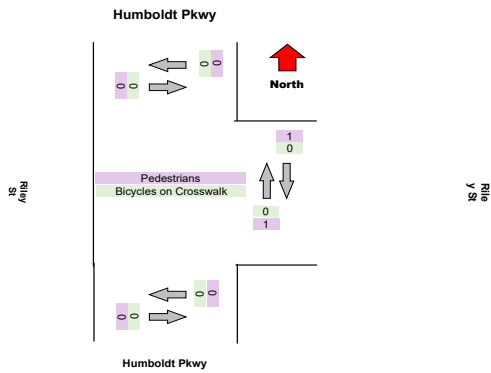
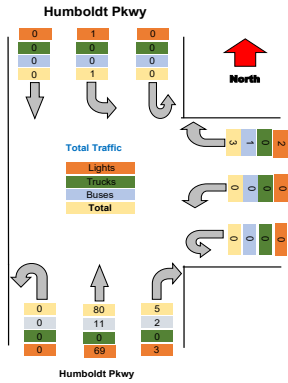

Turning Movement Peak Hour Data (PM)

4:30:00 PM

Leg Direction	Humboldt Pkwy Southbound						Riley St Westbound						Humboldt Pkwy Northbound						Total
	Thru	Left	U-Turn	App Total	Peds CW	Peds CCW	Right	Left	U-Turn	App Total	Peds CW	Peds CCW	Right	Thru	U-Turn	App Total	Peds CW	Peds CCW	
4:30:00 PM	0	0	0	0	0	0	6	0	0	6	0	0	2	25	0	27	0	0	33
4:45:00 PM	0	0	0	0	0	0	3	0	0	3	0	0	3	16	0	19	0	0	22
5:00:00 PM	0	0	0	0	0	0	3	0	0	3	1	1	3	18	0	21	0	0	24
5:15:00 PM	0	0	0	0	0	0	3	0	0	3	1	1	1	24	0	25	0	0	28
<b>Grand Total</b>	0	0	0	0	0	0	15	0	0	15	2	2	9	83	0	92	0	0	107
% Approach	#####	#####	#####	0.0%	0.0%	0.0%	14.2%	0.0%	0.0%	0.0%	0.0%	0.0%	45.1%	41.7%	0.0%	0.0%	0.0%	0.0%	
% Total	0.0%	0.0%	0.0%	0.0%	0.0%	0.0%	14.0%	0.0%	0.0%	14.0%	0.0%	0.0%	8.4%	77.6%	0.0%	86.0%	0.0%	0.0%	
PHF	0.000	0.000	0.000	0.000	0.000	0.000	0.625	0.000	0.000	0.625	0.000	0.000	0.750	0.830	0.000	0.852	0.000	0.000	0.811
Lights	0	0	0	0	0	0	14	0	0	14	0	0	8	79	0	87	0	0	101
% Lights	0.0%	0.0%	0.0%	0.0%	0.0%	0.0%	93.3%	0.0%	0.0%	93.3%	0.0%	0.0%	88.9%	95.2%	0.0%	94.6%	0.0%	0.0%	94.4%
Trucks	0	0	0	0	0	0	0	0	0	0	0	0	0	0	0	0	0	0	0
% Trucks	0.0%	0.0%	0.0%	0.0%	0.0%	0.0%	0.0%	0.0%	0.0%	0.0%	0.0%	0.0%	0.0%	0.0%	0.0%	0.0%	0.0%	0.0%	0.0%
Buses	0	0	0	0	0	0	1	0	0	1	0	0	1	4	0	5	0	0	6
% Buses	0.0%	0.0%	0.0%	0.0%	0.0%	0.0%	6.7%	0.0%	0.0%	6.7%	0.0%	0.0%	11.1%	4.8%	0.0%	16.9%	0.0%	0.0%	5.6%
Pedestrians	0	0	0	0	0	0	0	0	0	0	2	1	0	0	0	0	0	0	3
% Pedestrians	0.0%	0.0%	0.0%	0.0%	0.0%	0.0%	0.0%	0.0%	0.0%	0.0%	100.0%	50.0%	0.0%	0.0%	0.0%	0.0%	0.0%	0.0%	3.0%
Bicycles on Crosswalk	0	0	0	0	0	0	0	0	0	0	0	1	0	0	0	0	0	0	1
% Bicycles on Crosswalk	0.0%	0.0%	0.0%	0.0%	0.0%	0.0%	0.0%	0.0%	0.0%	0.0%	0.0%	50.0%	0.0%	0.0%	0.0%	0.0%	0.0%	0.0%	1.0%

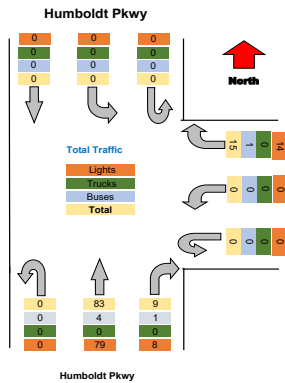

Riley St

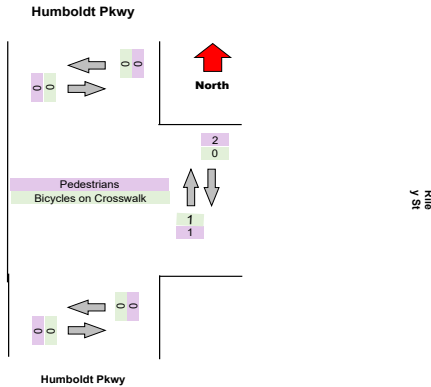

Riley St



Turning Movement Data Plot

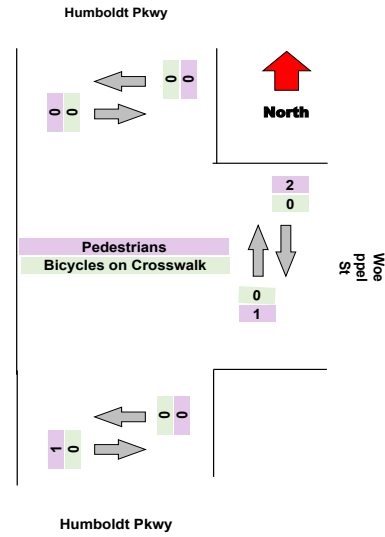
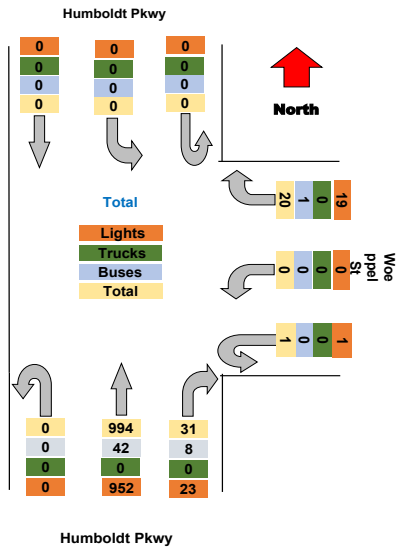

Turning Movement Peak Hour Data (AM)

7:30:00 AM

Leg Direction	Humboldt Pkwy Southbound						Woepfel St Westbound						Humboldt Pkwy Northbound						Total
	Thru	Left	U-Turn	App Total	Peds CW	Peds CCW	Right	Left	U-Turn	App Total	Peds CW	Peds CCW	Right	Thru	U-Turn	App Total	Peds CW	Peds CCW	
7:30:00 AM	0	0	0	0	0	0	1	0	1	2	0	0	1	57	0	58	0	0	60
7:45:00 AM	0	0	0	0	0	0	2	0	0	2	0	0	3	65	0	68	0	0	70
8:00:00 AM	0	0	0	0	0	0	1	0	0	1	0	0	0	62	0	62	0	0	63
8:15:00 AM	0	0	0	0	0	0	1	0	0	1	1	1	2	70	0	74	0	0	75
<b>Grand Total</b>	<b>0</b>	<b>0</b>	<b>0</b>	<b>0</b>	<b>0</b>	<b>0</b>	<b>5</b>	<b>0</b>	<b>1</b>	<b>6</b>	<b>1</b>	<b>1</b>	<b>6</b>	<b>254</b>	<b>0</b>	<b>262</b>	<b>0</b>	<b>0</b>	<b>268</b>
% Approach	#####	#####	#####	0.0%	0.0%	0.0%	14.2%	0.0%	0.0%	0.0%	0.0%	0.0%	45.1%	41.7%	0.0%	0.0%	0.0%	0.0%	
% Total	0.0%	0.0%	0.0%	0.0%	0.0%	0.0%	1.9%	0.0%	0.4%	2.2%	0.0%	0.0%	2.2%	94.8%	0.0%	97.8%	0.0%	0.0%	
PHF	0.000	0.000	0.000	0.000	0.000	0.000	0.625	0.000	0.250	0.750	0.000	0.000	0.500	0.907	0.000	0.885	0.000	0.000	0.893
Lights	0	0	0	0	0	0	5	0	1	6	0	0	2	241	0	243	0	0	249
% Lights	0.0%	0.0%	0.0%	0.0%	0.0%	0.0%	#####	0.0%	100.0%	100.0%	0.0%	0.0%	33.3%	94.9%	0.0%	92.7%	0.0%	0.0%	92.9%
Trucks	0	0	0	0	0	0	0	0	0	0	0	0	0	0	0	0	0	0	0
% Trucks	0.0%	0.0%	0.0%	0.0%	0.0%	0.0%	0.0%	0.0%	0.0%	0.0%	0.0%	0.0%	0.0%	0.0%	0.0%	0.0%	0.0%	0.0%	0.0%
Buses	0	0	0	0	0	0	0	0	0	0	0	0	4	13	0	17	0	0	17
% Buses	0.0%	0.0%	0.0%	0.0%	0.0%	0.0%	0.0%	0.0%	0.0%	0.0%	0.0%	0.0%	66.7%	5.1%	0.0%	0.0%	0.0%	0.0%	6.3%
Pedestrians	0	0	0	0	0	0	0	0	0	0	1	1	0	0	0	0	0	0	0
% Pedestrians	0.0%	0.0%	0.0%	0.0%	0.0%	0.0%	0.0%	0.0%	0.0%	0.0%	100.0%	100.0%	0.0%	0.0%	0.0%	0.0%	0.0%	0.0%	0.0%
Bicycles on Crosswalk	0	0	0	0	0	0	0	0	0	0	0	0	0	0	0	0	0	0	0
% Bicycles on Crosswalk	0.0%	0.0%	0.0%	0.0%	0.0%	0.0%	0.0%	0.0%	0.0%	0.0%	0.0%	0.0%	0.0%	0.0%	0.0%	0.0%	0.0%	0.0%	0.0%

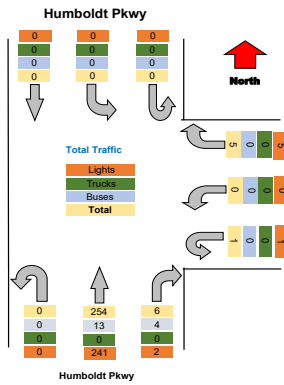

Woepfel St

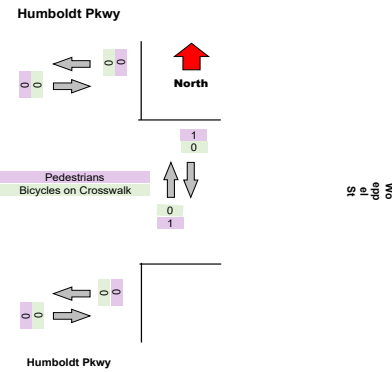

Humboldt Pkwy

Turning Movement Peak Hour Data (PM)  
 4:15:00 PM

Leg Direction	Humboldt Pkwy Southbound						Woepfel St Westbound						Humboldt Pkwy Northbound						Total
	Thru	Left	U-Turn	App Total	Peds CW	Peds CCW	Right	Left	U-Turn	App Total	Peds CW	Peds CCW	Right	Thru	U-Turn	App Total	Peds CW	Peds CCW	
4:15:00 PM	0	0	0	0	0	0	4	0	0	4	0	0	2	72	0	74	0	1	78
4:30:00 PM	0	0	0	0	0	0	1	0	0	1	0	0	2	64	0	66	0	0	67
4:45:00 PM	0	0	0	0	0	0	1	0	0	1	0	0	4	75	0	79	0	0	80
5:00:00 PM	0	0	0	0	0	0	1	0	0	1	0	0	4	77	0	81	0	0	82
<b>Grand Total</b>	<b>0</b>	<b>0</b>	<b>0</b>	<b>0</b>	<b>0</b>	<b>0</b>	<b>7</b>	<b>0</b>	<b>0</b>	<b>7</b>	<b>0</b>	<b>0</b>	<b>12</b>	<b>288</b>	<b>0</b>	<b>300</b>	<b>0</b>	<b>1</b>	<b>307</b>
% Approach	#####	#####	#####	0.0%	0.0%	0.0%	14.2%	0.0%	0.0%	0.0%	0.0%	0.0%	45.1%	41.7%	0.0%	0.0%	0.0%	0.0%	
% Total	0.0%	0.0%	0.0%	0.0%	0.0%	0.0%	2.3%	0.0%	0.0%	2.3%	0.0%	0.0%	3.9%	93.8%	0.0%	97.7%	0.0%	0.0%	
PHF	0.000	0.000	0.000	0.000	0.000	0.000	0.438	0.000	0.000	0.438	0.000	0.000	0.750	0.935	0.000	0.926	0.000	0.000	0.936
Lights	0	0	0	0	0	0	6	0	0	6	0	0	10	276	0	286	0	0	292
% Lights	0.0%	0.0%	0.0%	0.0%	0.0%	0.0%	85.7%	0.0%	0.0%	85.7%	0.0%	0.0%	83.3%	95.8%	0.0%	95.3%	0.0%	0.0%	95.1%
Trucks	0	0	0	0	0	0	0	0	0	0	0	0	0	0	0	0	0	0	0
% Trucks	0.0%	0.0%	0.0%	0.0%	0.0%	0.0%	0.0%	0.0%	0.0%	0.0%	0.0%	0.0%	0.0%	0.0%	0.0%	0.0%	0.0%	0.0%	0.0%
Buses	0	0	0	0	0	0	1	0	0	1	0	0	2	12	0	14	0	0	15
% Buses	0.0%	0.0%	0.0%	0.0%	0.0%	0.0%	14.3%	0.0%	0.0%	0.0%	0.0%	0.0%	16.7%	4.2%	0.0%	0.0%	0.0%	0.0%	4.9%
Pedestrians	0	0	0	0	0	0	0	0	0	0	0	0	0	0	0	0	0	1	0
% Pedestrians	0.0%	0.0%	0.0%	0.0%	0.0%	0.0%	0.0%	0.0%	0.0%	0.0%	0.0%	0.0%	0.0%	0.0%	0.0%	0.0%	0.0%	100.0%	0.0%
Bicycles on Crosswalk	0	0	0	0	0	0	0	0	0	0	0	0	0	0	0	0	0	0	0
% Bicycles on Crosswalk	0.0%	0.0%	0.0%	0.0%	0.0%	0.0%	0.0%	0.0%	0.0%	0.0%	0.0%	0.0%	0.0%	0.0%	0.0%	0.0%	0.0%	0.0%	0.0%

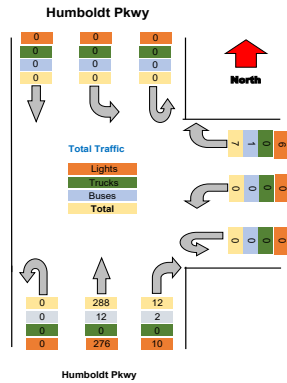

View  
 from  
 East

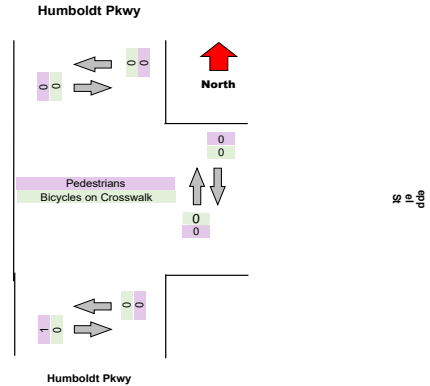

View  
 from  
 West





Turning Movement Data Plot

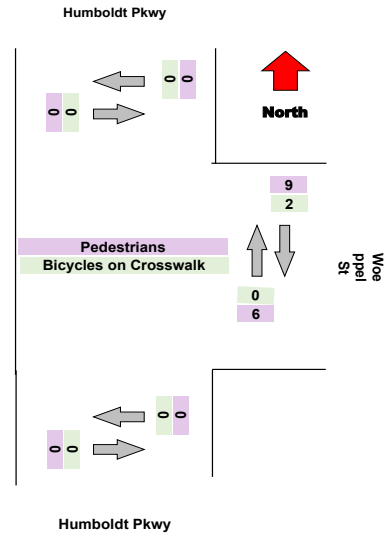
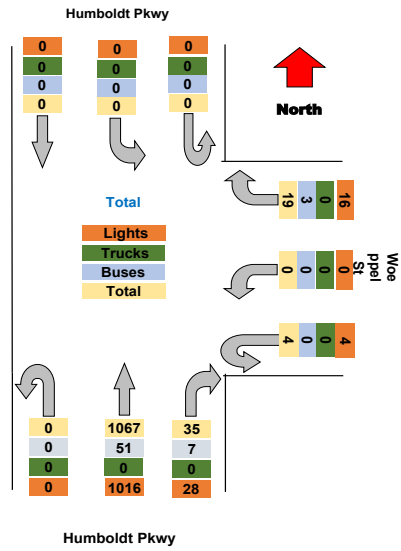

**Turning Movement Peak Hour Data (AM)**  
 7:30:00 AM

Leg Direction	Humboldt Pkwy						Woepfel St Westbound						Humboldt Pkwy Northbound						Total
	Thru	Left	U-Turn	App Total	Peds CW	Peds CCW	Right	Left	U-Turn	App Total	Peds CW	Peds CCW	Right	Thru	U-Turn	App Total	Peds CW	Peds CCW	
7:30:00 AM	0	0	0	0	0	0	0	0	1	1	2	2	1	53	0	58	0	0	59
7:45:00 AM	0	0	0	0	0	0	0	0	0	0	0	0	1	69	0	70	0	0	70
8:00:00 AM	0	0	0	0	0	0	1	0	0	1	1	0	1	83	0	85	0	0	86
8:15:00 AM	0	0	0	0	0	0	3	0	0	3	0	0	2	47	0	49	0	0	52
<b>Grand Total</b>	0	0	0	0	0	0	4	0	1	5	3	2	5	252	0	262	0	0	267
% Approach	#####	#####	#####	0.0%	0.0%	0.0%	14.2%	0.0%	0.0%	0.0%	0.0%	0.0%	45.1%	41.7%	0.0%	0.0%	0.0%	0.0%	
% Total	0.0%	0.0%	0.0%	0.0%	0.0%	0.0%	1.5%	0.0%	0.4%	1.9%	0.0%	0.0%	1.9%	94.4%	0.0%	98.1%	0.0%	0.0%	
PHF	0.000	0.000	0.000	0.000	0.000	0.000	0.333	0.000	0.250	0.417	0.000	0.000	0.625	0.759	0.000	0.771	0.000	0.000	0.776
Lights	0	0	0	0	0	0	4	0	1	5	0	2	2	238	0	240	0	0	245
% Lights	0.0%	0.0%	0.0%	0.0%	0.0%	0.0%	100.0%	0.0%	100.0%	100.0%	0.0%	0.0%	40.0%	94.4%	0.0%	91.6%	0.0%	0.0%	91.8%
Trucks	0	0	0	0	0	0	0	0	0	0	0	0	0	0	0	0	0	0	0
% Trucks	0.0%	0.0%	0.0%	0.0%	0.0%	0.0%	0.0%	0.0%	0.0%	0.0%	0.0%	0.0%	0.0%	0.0%	0.0%	0.0%	0.0%	0.0%	0.0%
Buses	0	0	0	0	0	0	0	0	0	0	0	0	3	14	0	17	0	0	17
% Buses	0.0%	0.0%	0.0%	0.0%	0.0%	0.0%	0.0%	0.0%	0.0%	0.0%	0.0%	0.0%	60.0%	5.6%	0.0%	0.0%	0.0%	0.0%	6.4%
Pedestrians	0	0	0	0	0	0	0	0	0	0	3	2	0	0	0	0	0	0	0
% Pedestrians	0.0%	0.0%	0.0%	0.0%	0.0%	0.0%	0.0%	0.0%	0.0%	0.0%	100.0%	100.0%	0.0%	0.0%	0.0%	0.0%	0.0%	0.0%	0.0%
Bicycles on Crosswalk	0	0	0	0	0	0	0	0	0	0	0	0	0	0	0	0	0	0	0
% Bicycles on Crosswalk	0.0%	0.0%	0.0%	0.0%	0.0%	0.0%	0.0%	0.0%	0.0%	0.0%	0.0%	0.0%	0.0%	0.0%	0.0%	0.0%	0.0%	0.0%	0.0%

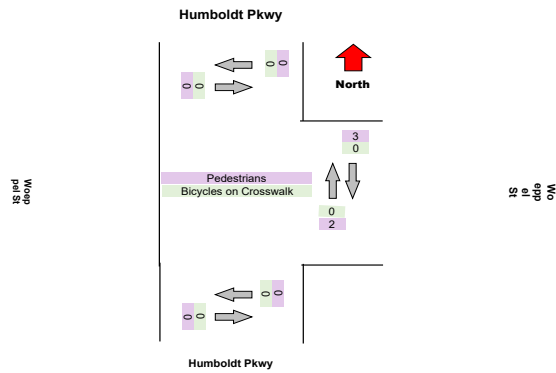
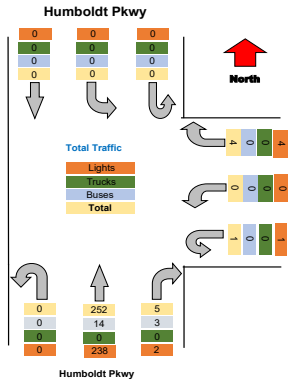

Turning Movement Peak Hour Data (PM)  
 4:15:00 PM

Leg Direction	Humboldt Pkwy Southbound						Woepfel St Westbound						Humboldt Pkwy Northbound						Total
	Thru	Left	U-Turn	App Total	Peds CW	Peds CCW	Right	Left	U-Turn	App Total	Peds CW	Peds CCW	Right	Thru	U-Turn	App Total	Peds CW	Peds CCW	
4:15:00 PM	0	0	0	0	0	0	3	0	1	4	1	0	3	93	0	96	0	0	100
4:30:00 PM	0	0	0	0	0	0	1	0	0	1	0	1	2	86	0	88	0	0	89
4:45:00 PM	0	0	0	0	0	0	1	0	0	1	1	2	5	74	0	79	0	0	80
5:00:00 PM	0	0	0	0	0	0	1	0	1	2	3	1	2	69	0	71	0	0	73
<b>Grand Total</b>	<b>0</b>	<b>0</b>	<b>0</b>	<b>0</b>	<b>0</b>	<b>0</b>	<b>6</b>	<b>0</b>	<b>2</b>	<b>8</b>	<b>5</b>	<b>4</b>	<b>12</b>	<b>322</b>	<b>0</b>	<b>334</b>	<b>0</b>	<b>0</b>	<b>342</b>
% Approach	#####	#####	#####	0.0%	0.0%	0.0%	14.2%	0.0%	0.0%	0.0%	0.0%	0.0%	45.1%	41.7%	0.0%	0.0%	0.0%	0.0%	
% Total	0.0%	0.0%	0.0%	0.0%	0.0%	0.0%	1.8%	0.0%	0.6%	2.3%	0.0%	0.0%	3.5%	94.2%	0.0%	97.7%	0.0%	0.0%	
PHF	0.000	0.000	0.000	0.000	0.000	0.000	0.500	0.000	0.500	0.500	0.000	0.000	0.600	0.866	0.000	0.870	0.000	0.000	0.855
Lights	0	0	0	0	0	0	4	0	2	6	0	0	10	305	0	315	0	0	321
% Lights	0.0%	0.0%	0.0%	0.0%	0.0%	0.0%	66.7%	0.0%	100.0%	75.0%	0.0%	0.0%	83.3%	94.7%	0.0%	94.3%	0.0%	0.0%	93.9%
Trucks	0	0	0	0	0	0	0	0	0	0	0	0	0	0	0	0	0	0	0
% Trucks	0.0%	0.0%	0.0%	0.0%	0.0%	0.0%	0.0%	0.0%	0.0%	0.0%	0.0%	0.0%	0.0%	0.0%	0.0%	0.0%	0.0%	0.0%	0.0%
Buses	0	0	0	0	0	0	2	0	0	2	0	0	2	17	0	19	0	0	21
% Buses	0.0%	0.0%	0.0%	0.0%	0.0%	0.0%	33.3%	0.0%	0.0%	0.0%	0.0%	0.0%	16.7%	5.3%	0.0%	0.0%	0.0%	0.0%	6.1%
Pedestrians	0	0	0	0	0	0	0	0	0	0	3	4	0	0	0	0	0	0	0
% Pedestrians	0.0%	0.0%	0.0%	0.0%	0.0%	0.0%	0.0%	0.0%	0.0%	0.0%	60.0%	100.0%	0.0%	0.0%	0.0%	0.0%	0.0%	0.0%	0.0%
Bicycles on Crosswalk	0	0	0	0	0	0	0	0	0	0	2	0	0	0	0	0	0	0	0
% Bicycles on Crosswalk	0.0%	0.0%	0.0%	0.0%	0.0%	0.0%	0.0%	0.0%	0.0%	0.0%	40.0%	0.0%	0.0%	0.0%	0.0%	0.0%	0.0%	0.0%	0.0%

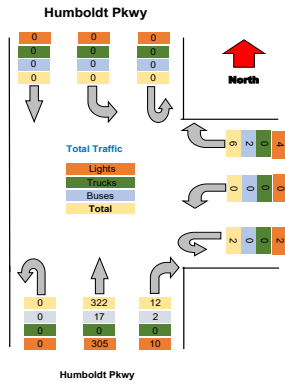

View from East

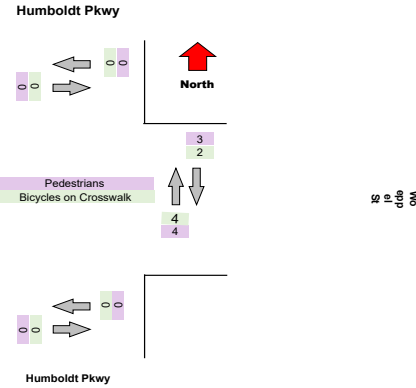

View from West

Intersection: Elm St Pine St  
 Location: Kennett Square, PA  
 Site: 01  
 Survey Date: Wednesday, 04-28-2021  
 GPS: 42.948550, -72.790034



Project	Labella
Project Code	Labella
Site Name	H
Legs and Movements	All Processed Legs & Movements
Bin Size	15 minutes
Survey Date	2021-10-28, Thursday
Location	H
Latitude and Longitude	42.911816, -78.843102

	Start	End	PHF
Forced Peak AM	2021/10/28 07:30:00	2021/10/28 08:30:00	0.865
Forced Peak PM	2021/10/28 16:30:00	2021/10/28 17:30:00	0.948
AM Peak	2021/10/28 07:30:00	2021/10/28 08:30:00	0.865
PM Peak	2021/10/28 16:15:00	2021/10/28 17:15:00	0.827

Turning Movement Data

Leg Direction	Humboldt Pkwy Southbound						Woepfel St Westbound						Humboldt Pkwy Northbound						Total	
	Thru	Left	U-Turn	App	Total	Peds CW/Peds CCW	Right	Left	U-Turn	App	Total	Peds CW/Peds CCW	Right	Thru	U-Turn	App	Total	Peds CW/Peds CCW		
Start Time																				
6:30:00 AM	0	0	0	0	0	0	1	0	0	1	0	0	0	27	0	27	0	0	0	28
6:45:00 AM	0	0	0	0	0	0	1	0	0	1	0	0	3	49	0	52	0	0	0	53
<b>Hourly Total</b>	<b>0</b>	<b>0</b>	<b>0</b>	<b>0</b>	<b>0</b>	<b>0</b>	<b>2</b>	<b>0</b>	<b>0</b>	<b>2</b>	<b>0</b>	<b>0</b>	<b>3</b>	<b>76</b>	<b>0</b>	<b>79</b>	<b>0</b>	<b>0</b>	<b>0</b>	<b>81</b>
7:00:00 AM	0	0	0	0	0	0	1	0	0	1	0	0	2	44	0	46	0	0	0	47
7:15:00 AM	0	0	0	0	0	0	1	0	0	1	4	1	1	39	0	45	0	0	0	46
7:30:00 AM	0	0	0	0	0	0	0	0	0	0	2	1	1	54	0	58	0	0	0	58
7:45:00 AM	0	0	0	0	0	0	1	0	0	1	0	0	2	73	0	75	0	0	0	76
<b>Hourly Total</b>	<b>0</b>	<b>0</b>	<b>0</b>	<b>0</b>	<b>0</b>	<b>0</b>	<b>3</b>	<b>0</b>	<b>0</b>	<b>3</b>	<b>6</b>	<b>2</b>	<b>6</b>	<b>210</b>	<b>0</b>	<b>224</b>	<b>0</b>	<b>0</b>	<b>0</b>	<b>227</b>
8:00:00 AM	0	0	0	0	0	0	2	0	0	2	0	0	0	76	0	76	0	0	0	78
8:15:00 AM	0	1	0	1	0	0	0	0	0	0	0	0	2	55	0	57	0	0	0	58
<b>Hourly Total</b>	<b>0</b>	<b>1</b>	<b>0</b>	<b>1</b>	<b>0</b>	<b>0</b>	<b>2</b>	<b>0</b>	<b>0</b>	<b>2</b>	<b>0</b>	<b>0</b>	<b>2</b>	<b>131</b>	<b>0</b>	<b>133</b>	<b>0</b>	<b>0</b>	<b>0</b>	<b>136</b>
4:00:00 PM	0	0	0	0	0	0	5	0	0	5	1	0	2	93	0	95	0	0	0	100
4:15:00 PM	0	0	0	0	0	0	1	0	0	1	0	0	6	100	0	106	0	0	0	107
4:30:00 PM	0	0	0	0	0	0	0	0	0	0	0	0	3	77	0	80	0	4	0	80
4:45:00 PM	0	0	0	0	0	0	3	0	0	3	1	0	4	74	0	78	0	0	0	81
<b>Hourly Total</b>	<b>0</b>	<b>0</b>	<b>0</b>	<b>0</b>	<b>0</b>	<b>0</b>	<b>9</b>	<b>0</b>	<b>0</b>	<b>9</b>	<b>2</b>	<b>0</b>	<b>15</b>	<b>344</b>	<b>0</b>	<b>359</b>	<b>0</b>	<b>4</b>	<b>4</b>	<b>368</b>
5:00:00 PM	0	0	0	0	1	0	4	0	0	4	1	0	3	79	0	82	0	0	0	86
5:15:00 PM	0	0	0	0	0	0	0	0	0	0	1	1	0	79	0	79	0	0	0	79
5:30:00 PM	0	0	0	0	0	0	2	0	0	2	1	0	1	76	0	77	0	0	0	79
5:45:00 PM	0	0	0	0	0	0	1	0	0	1	0	0	1	69	0	70	0	0	0	71
<b>Hourly Total</b>	<b>0</b>	<b>0</b>	<b>0</b>	<b>0</b>	<b>1</b>	<b>0</b>	<b>7</b>	<b>0</b>	<b>0</b>	<b>7</b>	<b>3</b>	<b>1</b>	<b>5</b>	<b>303</b>	<b>0</b>	<b>308</b>	<b>0</b>	<b>0</b>	<b>0</b>	<b>315</b>
<b>Grand Total</b>	<b>0</b>	<b>1</b>	<b>0</b>	<b>1</b>	<b>1</b>	<b>0</b>	<b>23</b>	<b>0</b>	<b>0</b>	<b>23</b>	<b>11</b>	<b>3</b>	<b>31</b>	<b>1064</b>	<b>0</b>	<b>1103</b>	<b>0</b>	<b>4</b>	<b>4</b>	<b>1127</b>
<b>% Approach</b>	<b>0.0%</b>	<b>100.0%</b>	<b>0.0%</b>	<b>0.0%</b>	<b>0.0%</b>	<b>0.0%</b>	<b>100.0%</b>	<b>0.0%</b>	<b>0.0%</b>	<b>0.0%</b>	<b>0.0%</b>	<b>0.0%</b>	<b>2.8%</b>	<b>96.5%</b>	<b>0.0%</b>	<b>0.0%</b>	<b>0.0%</b>	<b>0.0%</b>	<b>0.0%</b>	<b>0.0%</b>
<b>% Total</b>	<b>0.0%</b>	<b>0.1%</b>	<b>0.0%</b>	<b>0.1%</b>	<b>0.0%</b>	<b>0.0%</b>	<b>2.0%</b>	<b>0.0%</b>	<b>0.0%</b>	<b>2.0%</b>	<b>0.0%</b>	<b>0.0%</b>	<b>2.8%</b>	<b>94.4%</b>	<b>0.0%</b>	<b>97.9%</b>	<b>0.0%</b>	<b>0.0%</b>	<b>0.0%</b>	<b>0.0%</b>
<b>Lights</b>	<b>0</b>	<b>1</b>	<b>0</b>	<b>1</b>	<b>0</b>	<b>0</b>	<b>20</b>	<b>0</b>	<b>0</b>	<b>20</b>	<b>0</b>	<b>0</b>	<b>24</b>	<b>1022</b>	<b>0</b>	<b>1046</b>	<b>0</b>	<b>0</b>	<b>0</b>	<b>1067</b>
<b>% Lights</b>	<b>0.0%</b>	<b>100.0%</b>	<b>0.0%</b>	<b>100.0%</b>	<b>0.0%</b>	<b>0.0%</b>	<b>87.0%</b>	<b>0.0%</b>	<b>0.0%</b>	<b>87.0%</b>	<b>0.0%</b>	<b>0.0%</b>	<b>77.4%</b>	<b>96.1%</b>	<b>0.0%</b>	<b>94.8%</b>	<b>0.0%</b>	<b>0.0%</b>	<b>0.0%</b>	<b>94.7%</b>
<b>Trucks</b>	<b>0</b>	<b>0</b>	<b>0</b>	<b>0</b>	<b>0</b>	<b>0</b>	<b>0</b>	<b>0</b>	<b>0</b>	<b>0</b>	<b>0</b>	<b>0</b>	<b>0</b>	<b>0</b>	<b>0</b>	<b>0</b>	<b>0</b>	<b>0</b>	<b>0</b>	<b>0</b>
<b>% Trucks</b>	<b>0.0%</b>	<b>0.0%</b>	<b>0.0%</b>	<b>0.0%</b>	<b>0.0%</b>	<b>0.0%</b>	<b>0.0%</b>	<b>0.0%</b>	<b>0.0%</b>	<b>0.0%</b>	<b>0.0%</b>	<b>0.0%</b>	<b>0.0%</b>	<b>0.0%</b>	<b>0.0%</b>	<b>0.0%</b>	<b>0.0%</b>	<b>0.0%</b>	<b>0.0%</b>	<b>0.0%</b>
<b>Buses</b>	<b>0</b>	<b>0</b>	<b>0</b>	<b>0</b>	<b>0</b>	<b>0</b>	<b>3</b>	<b>0</b>	<b>0</b>	<b>3</b>	<b>0</b>	<b>0</b>	<b>7</b>	<b>41</b>	<b>0</b>	<b>48</b>	<b>0</b>	<b>0</b>	<b>0</b>	<b>51</b>
<b>% Buses</b>	<b>0.0%</b>	<b>0.0%</b>	<b>0.0%</b>	<b>0.0%</b>	<b>0.0%</b>	<b>0.0%</b>	<b>0.0%</b>	<b>0.0%</b>	<b>0.0%</b>	<b>0.0%</b>	<b>0.0%</b>	<b>0.0%</b>	<b>22.6%</b>	<b>3.9%</b>	<b>0.0%</b>	<b>0.0%</b>	<b>0.0%</b>	<b>0.0%</b>	<b>0.0%</b>	<b>4.5%</b>
<b>Pedestrians</b>	<b>0</b>	<b>0</b>	<b>0</b>	<b>0</b>	<b>1</b>	<b>0</b>	<b>0</b>	<b>0</b>	<b>0</b>	<b>0</b>	<b>11</b>	<b>2</b>	<b>0</b>	<b>0</b>	<b>0</b>	<b>0</b>	<b>0</b>	<b>4</b>	<b>0</b>	<b>0</b>
<b>% Pedestrians</b>	<b>0.0%</b>	<b>0.0%</b>	<b>0.0%</b>	<b>0.0%</b>	<b>100.0%</b>	<b>0.0%</b>	<b>0.0%</b>	<b>0.0%</b>	<b>0.0%</b>	<b>0.0%</b>	<b>100.0%</b>	<b>66.7%</b>	<b>0.0%</b>	<b>0.0%</b>	<b>0.0%</b>	<b>0.0%</b>	<b>0.0%</b>	<b>100.0%</b>	<b>0.0%</b>	<b>0.0%</b>
<b>Bicycles on Crosswalk</b>	<b>0</b>	<b>0</b>	<b>0</b>	<b>0</b>	<b>0</b>	<b>0</b>	<b>0</b>	<b>0</b>	<b>0</b>	<b>0</b>	<b>0</b>	<b>1</b>	<b>0</b>	<b>0</b>	<b>0</b>	<b>0</b>	<b>0</b>	<b>0</b>	<b>0</b>	<b>0</b>
<b>% Bicycles on Crosswalk</b>	<b>0.0%</b>	<b>0.0%</b>	<b>0.0%</b>	<b>0.0%</b>	<b>0.0%</b>	<b>0.0%</b>	<b>0.0%</b>	<b>0.0%</b>	<b>0.0%</b>	<b>0.0%</b>	<b>0.0%</b>	<b>33.3%</b>	<b>0.0%</b>	<b>0.0%</b>	<b>0.0%</b>	<b>0.0%</b>	<b>0.0%</b>	<b>0.0%</b>	<b>0.0%</b>	<b>0.0%</b>

Turning Movement Data Plot

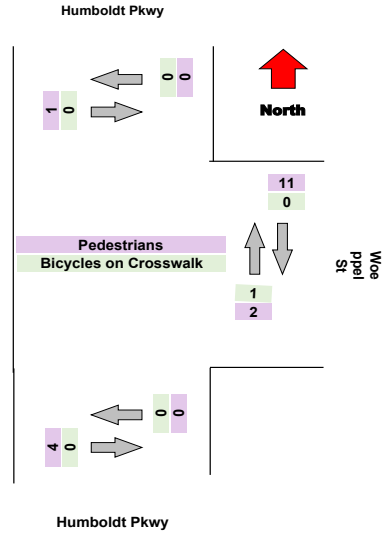
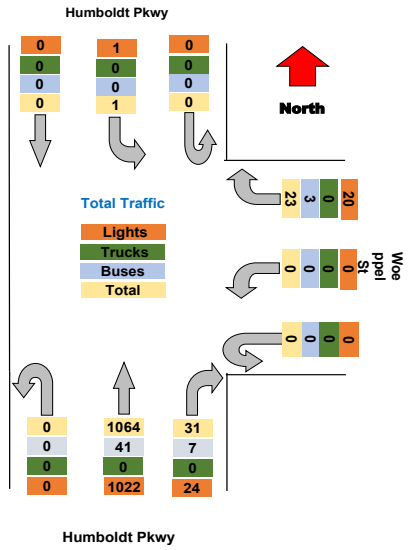

**Turning Movement Peak Hour Data (AM)**  
 7:30:00 AM

Leg	Humboldt Pkwy						Woepfel St						Humboldt Pkwy						Total
	Southbound						Westbound						Northbound						
Direction	Thru	Left	U-Turn	App	Total	Peds CW/Peds CCW	Right	Left	U-Turn	App	Total	Peds CW/Peds CCW	Right	Thru	U-Turn	App	Total	Peds CW/Peds CCW	
7:30:00 AM	0	0	0	0	0	0	0	0	0	0	2	1	1	54	0	0	58	0	0
7:45:00 AM	0	0	0	0	0	0	1	0	0	1	0	0	2	73	0	0	75	0	0
8:00:00 AM	0	0	0	0	0	0	2	0	0	2	0	0	0	76	0	0	76	0	0
8:15:00 AM	0	1	0	1	0	0	0	0	0	0	0	0	2	55	0	0	57	0	0
<b>Grand Total</b>	<b>0</b>	<b>1</b>	<b>0</b>	<b>1</b>	<b>0</b>	<b>0</b>	<b>3</b>	<b>0</b>	<b>0</b>	<b>3</b>	<b>0</b>	<b>1</b>	<b>5</b>	<b>258</b>	<b>0</b>	<b>0</b>	<b>266</b>	<b>0</b>	<b>0</b>
% Approach	0.0%	100.0%	0.0%	0.0%	0.0%	0.0%	14.2%	0.0%	0.0%	0.0%	0.0%	0.0%	45.1%	14.7%	0.0%	0.0%	0.0%	0.0%	0.0%
% Total	0.0%	0.4%	0.0%	0.4%	0.0%	0.0%	1.1%	0.0%	0.0%	1.1%	0.0%	0.0%	1.9%	95.6%	0.0%	0.0%	98.5%	0.0%	0.0%
PHF	0.000	0.250	0.000	0.250	0.000	0.000	0.375	0.000	0.000	0.375	0.000	0.000	0.625	0.849	0.000	0.000	0.875	0.000	0.000
Lights	0	1	0	1	0	0	3	0	0	3	0	0	2	244	0	0	246	0	0
% Lights	0.0%	100.0%	0.0%	100.0%	0.0%	0.0%	100.0%	0.0%	0.0%	100.0%	0.0%	0.0%	40.0%	94.6%	0.0%	0.0%	92.5%	0.0%	0.0%
Trucks	0	0	0	0	0	0	0	0	0	0	0	0	0	0	0	0	0	0	0
% Trucks	0.0%	0.0%	0.0%	0.0%	0.0%	0.0%	0.0%	0.0%	0.0%	0.0%	0.0%	0.0%	0.0%	0.0%	0.0%	0.0%	0.0%	0.0%	0.0%
Buses	0	0	0	0	0	0	0	0	0	0	0	0	3	14	0	0	17	0	0
% Buses	0.0%	0.0%	0.0%	0.0%	0.0%	0.0%	0.0%	0.0%	0.0%	0.0%	0.0%	0.0%	60.0%	5.4%	0.0%	0.0%	0.0%	0.0%	0.0%
Pedestrians	0	0	0	0	0	0	0	0	0	0	2	1	0	0	0	0	0	0	0
% Pedestrians	0.0%	0.0%	0.0%	0.0%	0.0%	0.0%	0.0%	0.0%	0.0%	0.0%	100.0%	100.0%	0.0%	0.0%	0.0%	0.0%	0.0%	0.0%	0.0%
Bicycles on Crosswalk	0	0	0	0	0	0	0	0	0	0	0	0	0	0	0	0	0	0	0
% Bicycles on Crosswalk	0.0%	0.0%	0.0%	0.0%	0.0%	0.0%	0.0%	0.0%	0.0%	0.0%	0.0%	0.0%	0.0%	0.0%	0.0%	0.0%	0.0%	0.0%	0.0%

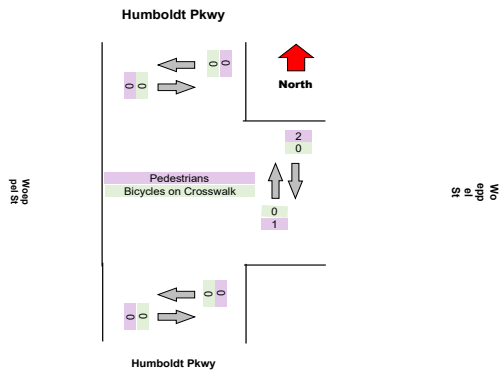
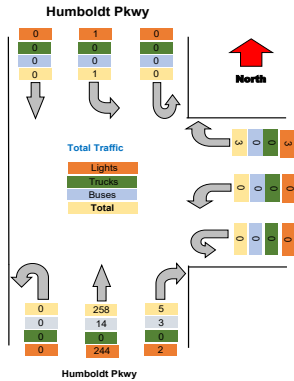

Turning Movement Peak Hour Data (PM)  
 4:15:00 PM

Leg Direction	Humboldt Pkwy Southbound						Woepfel St Westbound						Humboldt Pkwy Northbound						Total																			
	Thru	Left	U-Turn	App	Total	Peds	CW	Peds	CCW	Right	Left	U-Turn	App	Total	Peds	CW	Peds	CCW		Right	Thru	U-Turn	App	Total	Peds	CW	Peds	CCW										
4:15:00 PM	0	0	0	0	0	0	0	0	0	1	0	0	1	0	0	0	0	0	6	100	0	106	0	0	0	0	0	0	0	0	0	0	0	0	0	0	0	107
4:30:00 PM	0	0	0	0	0	0	0	0	0	0	0	0	0	0	0	0	0	0	3	77	0	80	0	0	0	0	0	0	0	0	0	0	0	0	0	0	80	
4:45:00 PM	0	0	0	0	0	0	0	0	0	3	0	0	3	1	0	0	0	0	4	74	0	78	0	0	0	0	0	0	0	0	0	0	0	0	0	0	81	
5:00:00 PM	0	0	0	0	0	1	0	0	0	4	0	0	4	1	0	0	0	0	3	79	0	82	0	0	0	0	0	0	0	0	0	0	0	0	0	0	86	
<b>Grand Total</b>	0	0	0	0	0	1	0	0	0	8	0	0	8	2	0	0	0	0	16	330	0	346	0	0	0	0	0	0	0	0	0	0	0	0	0	0	354	
% Approach	#####	#DIV/0!	#####	0.0%	0.0%	0.0%	0.0%	0.0%	0.0%	14.2%	0.0%	0.0%	0.0%	0.0%	0.0%	0.0%	0.0%	0.0%	45.1%	41.7%	0.0%	0.0%	0.0%	0.0%	0.0%	0.0%	0.0%	0.0%	0.0%	0.0%	0.0%	0.0%	0.0%	0.0%	0.0%	0.0%	0.0%	
% Total	0.0%	0.0%	0.0%	0.0%	0.0%	0.0%	0.0%	0.0%	0.0%	2.3%	0.0%	0.0%	2.3%	0.0%	0.0%	0.0%	0.0%	0.0%	4.5%	93.2%	0.0%	0.0%	0.0%	0.0%	0.0%	0.0%	0.0%	0.0%	0.0%	0.0%	0.0%	0.0%	0.0%	0.0%	0.0%	0.0%		
PHF	0.000	0.000	0.000	0.000	0.000	0.000	0.000	0.000	0.000	0.500	0.000	0.000	0.500	0.000	0.000	0.000	0.000	0.000	0.667	0.825	0.000	0.816	0.000	0.000	0.000	0.000	0.000	0.000	0.000	0.000	0.000	0.000	0.000	0.000	0.000	0.827		
Lights	0	0	0	0	0	0	0	0	0	6	0	0	6	0	0	0	0	0	14	317	0	331	0	0	0	0	0	0	0	0	0	0	0	0	0	0	0	337
% Lights	0.0%	0.0%	0.0%	0.0%	0.0%	0.0%	0.0%	0.0%	0.0%	75.0%	0.0%	0.0%	75.0%	0.0%	0.0%	0.0%	0.0%	0.0%	87.5%	96.1%	0.0%	0.0%	0.0%	0.0%	0.0%	0.0%	0.0%	0.0%	0.0%	0.0%	0.0%	0.0%	0.0%	0.0%	0.0%	0.0%	95.2%	
Trucks	0	0	0	0	0	0	0	0	0	0	0	0	0	0	0	0	0	0	0	0	0	0	0	0	0	0	0	0	0	0	0	0	0	0	0	0	0	0
% Trucks	0.0%	0.0%	0.0%	0.0%	0.0%	0.0%	0.0%	0.0%	0.0%	0.0%	0.0%	0.0%	0.0%	0.0%	0.0%	0.0%	0.0%	0.0%	0.0%	0.0%	0.0%	0.0%	0.0%	0.0%	0.0%	0.0%	0.0%	0.0%	0.0%	0.0%	0.0%	0.0%	0.0%	0.0%	0.0%	0.0%		
Buses	0	0	0	0	0	0	0	0	0	2	0	0	2	0	0	0	0	0	2	12	0	14	0	0	0	0	0	0	0	0	0	0	0	0	0	0	0	16
% Buses	0.0%	0.0%	0.0%	0.0%	0.0%	0.0%	0.0%	0.0%	0.0%	25.0%	0.0%	0.0%	0.0%	0.0%	0.0%	0.0%	0.0%	0.0%	12.5%	3.6%	0.0%	0.0%	0.0%	0.0%	0.0%	0.0%	0.0%	0.0%	0.0%	0.0%	0.0%	0.0%	0.0%	0.0%	0.0%	4.5%		
Pedestrians	0	0	0	0	1	0	0	0	0	0	0	0	0	2	0	0	0	0	0	0	0	0	0	0	0	0	0	0	0	0	0	0	0	0	0	0	0	4
% Pedestrians	0.0%	0.0%	0.0%	0.0%	100.0%	0.0%	0.0%	0.0%	0.0%	0.0%	0.0%	0.0%	0.0%	100.0%	0.0%	0.0%	0.0%	0.0%	0.0%	0.0%	0.0%	0.0%	0.0%	0.0%	0.0%	0.0%	0.0%	0.0%	0.0%	0.0%	0.0%	0.0%	0.0%	0.0%	100.0%	0.0%		
Bicycles on Crosswalk	0	0	0	0	0	0	0	0	0	0	0	0	0	0	0	0	0	0	0	0	0	0	0	0	0	0	0	0	0	0	0	0	0	0	0	0	0	0
% Bicycles on Crosswalk	0.0%	0.0%	0.0%	0.0%	0.0%	0.0%	0.0%	0.0%	0.0%	0.0%	0.0%	0.0%	0.0%	0.0%	0.0%	0.0%	0.0%	0.0%	0.0%	0.0%	0.0%	0.0%	0.0%	0.0%	0.0%	0.0%	0.0%	0.0%	0.0%	0.0%	0.0%	0.0%	0.0%	0.0%	0.0%	0.0%		

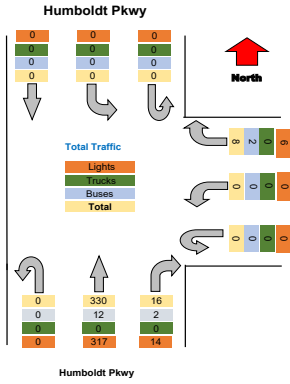

Woepfel St

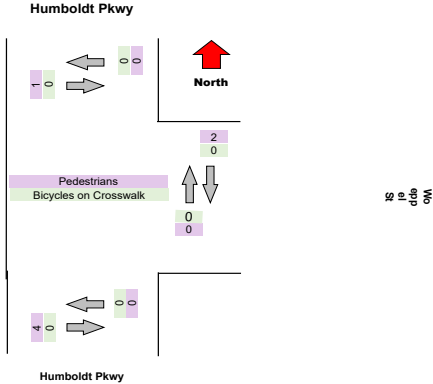

Woepfel St





Turning Movement Data Plot

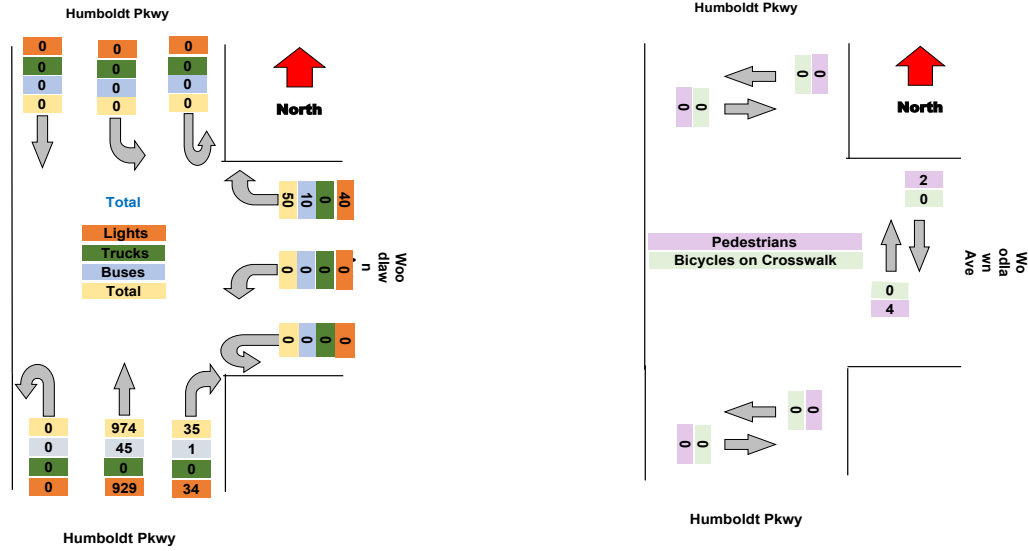

Turning Movement Peak Hour Data (AM)  
 7:30:00 AM

Leg	Humboldt Pkwy						Woodlawn Ave						Humboldt Pkwy						Total											
	Southbound						Westbound						Northbound																	
Direction	Thru	Left	U-Turn	App	Total	Peds	CW	Peds	CCW	Right	Left	U-Turn	App	Total	Peds	CW	Peds	CCW	Right	Thru	U-Turn	App	Total	Peds	CW	Peds	CCW			
7:30:00 AM	0	0	0	0	0	0	0	0	0	3	0	0	3	0	0	0	0	0	0	2	54	0	56	0	0	0	0	0		
7:45:00 AM	0	0	0	0	0	0	0	0	0	1	0	0	1	0	0	0	0	0	0	0	70	0	70	0	0	0	0	0		
8:00:00 AM	0	0	0	0	0	0	0	0	0	2	0	0	2	0	0	0	0	0	0	2	63	0	65	0	0	0	0	0		
8:15:00 AM	0	0	0	0	0	0	0	0	0	4	0	0	4	0	0	0	0	0	0	4	66	0	70	0	0	0	0	0		
<b>Grand Total</b>	<b>0</b>	<b>0</b>	<b>0</b>	<b>0</b>	<b>0</b>	<b>0</b>	<b>0</b>	<b>0</b>	<b>0</b>	<b>10</b>	<b>0</b>	<b>0</b>	<b>10</b>	<b>0</b>	<b>0</b>	<b>0</b>	<b>0</b>	<b>0</b>	<b>8</b>	<b>253</b>	<b>0</b>	<b>261</b>	<b>0</b>	<b>0</b>	<b>0</b>	<b>0</b>	<b>0</b>			
% Approach	#####	#####	#####	0.0%	0.0%	0.0%	14.2%	0.0%	0.0%	0.0%	0.0%	0.0%	45.1%	41.7%	0.0%	0.0%	0.0%	0.0%	14.2%	0.0%	0.0%	0.0%	0.0%	0.0%	3.0%	93.4%	0.0%	96.3%	0.0%	0.0%
% Total	0.0%	0.0%	0.0%	0.0%	0.0%	0.0%	3.7%	0.0%	0.0%	3.7%	0.0%	0.0%	3.0%	93.4%	0.0%	96.3%	0.0%	0.0%	3.0%	93.4%	0.0%	96.3%	0.0%	0.0%	0.0%	0.0%	0.0%	0.0%	0.0%	0.0%
PHF	0.000	0.000	0.000	0.000	0.000	0.000	0.625	0.000	0.000	0.625	0.000	0.000	0.500	0.904	0.000	0.932	0.000	0.000	0.625	0.000	0.000	0.625	0.000	0.000	0.000	0.000	0.000	0.000	0.000	0.000
Lights	0	0	0	0	0	0	0	0	0	9	0	0	9	0	0	0	0	0	7	240	0	247	0	0	0	0	0			
% Lights	0.0%	0.0%	0.0%	0.0%	0.0%	0.0%	90.0%	0.0%	0.0%	90.0%	0.0%	0.0%	87.5%	94.9%	0.0%	94.6%	0.0%	0.0%	87.5%	94.9%	0.0%	94.6%	0.0%	0.0%	94.5%	0.0%	0.0%	94.5%	0.0%	0.0%
Trucks	0	0	0	0	0	0	0	0	0	0	0	0	0	0	0	0	0	0	0	0	0	0	0	0	0	0	0			
% Trucks	0.0%	0.0%	0.0%	0.0%	0.0%	0.0%	0.0%	0.0%	0.0%	0.0%	0.0%	0.0%	0.0%	0.0%	0.0%	0.0%	0.0%	0.0%	0.0%	0.0%	0.0%	0.0%	0.0%	0.0%	0.0%	0.0%	0.0%	0.0%	0.0%	0.0%
Buses	0	0	0	0	0	0	0	0	0	1	0	0	1	0	0	0	0	0	1	13	0	14	0	0	0	0	0			
% Buses	0.0%	0.0%	0.0%	0.0%	0.0%	0.0%	10.0%	0.0%	0.0%	10.0%	0.0%	0.0%	12.5%	5.1%	0.0%	5.0%	0.0%	0.0%	12.5%	5.1%	0.0%	5.0%	0.0%	0.0%	5.5%	0.0%	0.0%	5.5%	0.0%	0.0%
Pedestrians	0	0	0	0	0	0	0	0	0	0	0	0	0	0	0	0	0	0	0	0	0	0	0	0	0	0	0			
% Pedestrians	0.0%	0.0%	0.0%	0.0%	0.0%	0.0%	0.0%	0.0%	0.0%	0.0%	0.0%	0.0%	0.0%	0.0%	0.0%	0.0%	0.0%	0.0%	0.0%	0.0%	0.0%	0.0%	0.0%	0.0%	0.0%	0.0%	0.0%	0.0%	0.0%	0.0%
Bicycles on Crosswalk	0	0	0	0	0	0	0	0	0	0	0	0	0	0	0	0	0	0	0	0	0	0	0	0	0	0	0			
% Bicycles on Crosswalk	0.0%	0.0%	0.0%	0.0%	0.0%	0.0%	0.0%	0.0%	0.0%	0.0%	0.0%	0.0%	0.0%	0.0%	0.0%	0.0%	0.0%	0.0%	0.0%	0.0%	0.0%	0.0%	0.0%	0.0%	0.0%	0.0%	0.0%	0.0%	0.0%	0.0%

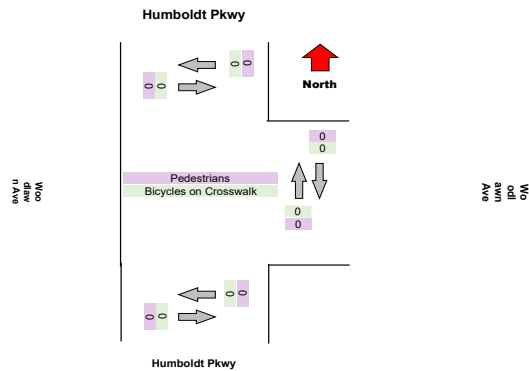
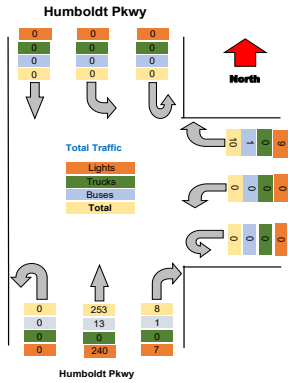

Turning Movement Peak Hour Data (PM)  
 4:30:00 PM

Leg Direction	Humboldt Pkwy						Woodlawn Ave						Humboldt Pkwy						Total
	Southbound			Westbound			Westbound			Northbound									
Start Time	Thru	Left	U-Turn	App Total	Peds CW	Peds CCW	Right	Left	U-Turn	App Total	Peds CW	Peds CCW	Right	Thru	U-Turn	App Total	Peds CW	Peds CCW	
4:30:00 PM	0	0	0	0	0	0	4	0	0	4	1	0	1	66	0	67	0	0	71
4:45:00 PM	0	0	0	0	0	0	5	0	0	5	0	0	2	75	0	77	0	0	82
5:00:00 PM	0	0	0	0	0	0	3	0	0	3	0	0	3	69	0	72	0	0	75
5:15:00 PM	0	0	0	0	0	0	8	0	0	8	0	0	1	72	0	73	0	0	81
<b>Grand Total</b>	<b>0</b>	<b>0</b>	<b>0</b>	<b>0</b>	<b>0</b>	<b>0</b>	<b>20</b>	<b>0</b>	<b>0</b>	<b>20</b>	<b>1</b>	<b>0</b>	<b>7</b>	<b>282</b>	<b>0</b>	<b>289</b>	<b>0</b>	<b>0</b>	<b>309</b>
% Approach	#####	#####	#####	0.0%	0.0%	0.0%	14.2%	0.0%	0.0%	0.0%	0.0%	0.0%	45.1%	41.7%	0.0%	0.0%	0.0%	0.0%	
% Total	0.0%	0.0%	0.0%	0.0%	0.0%	0.0%	6.5%	0.0%	0.0%	6.5%	0.0%	0.0%	2.3%	91.3%	0.0%	93.5%	0.0%	0.0%	
PHF	0.000	0.000	0.000	0.000	0.000	0.000	0.625	0.000	0.000	0.625	0.000	0.000	0.583	0.940	0.000	0.938	0.000	0.000	0.942
Lights	0	0	0	0	0	0	17	0	0	17	0	0	7	274	0	281	0	0	288
% Lights	0.0%	0.0%	0.0%	0.0%	0.0%	0.0%	85.0%	0.0%	0.0%	85.0%	0.0%	0.0%	100.0%	97.2%	0.0%	97.2%	0.0%	0.0%	96.4%
Trucks	0	0	0	0	0	0	0	0	0	0	0	0	0	0	0	0	0	0	0
% Trucks	0.0%	0.0%	0.0%	0.0%	0.0%	0.0%	0.0%	0.0%	0.0%	0.0%	0.0%	0.0%	0.0%	0.0%	0.0%	0.0%	0.0%	0.0%	0.0%
Buses	0	0	0	0	0	0	3	0	0	3	0	0	0	8	0	8	0	0	11
% Buses	0.0%	0.0%	0.0%	0.0%	0.0%	0.0%	15.0%	0.0%	0.0%	0.0%	0.0%	0.0%	0.0%	2.8%	0.0%	0.0%	0.0%	0.0%	3.6%
Pedestrians	0	0	0	0	0	0	0	0	0	0	1	0	0	0	0	0	0	0	0
% Pedestrians	0.0%	0.0%	0.0%	0.0%	0.0%	0.0%	0.0%	0.0%	0.0%	0.0%	100.0%	0.0%	0.0%	0.0%	0.0%	0.0%	0.0%	0.0%	0.0%
Bicycles on Crosswalk	0	0	0	0	0	0	0	0	0	0	0	0	0	0	0	0	0	0	0
% Bicycles on Crosswalk	0.0%	0.0%	0.0%	0.0%	0.0%	0.0%	0.0%	0.0%	0.0%	0.0%	0.0%	0.0%	0.0%	0.0%	0.0%	0.0%	0.0%	0.0%	0.0%

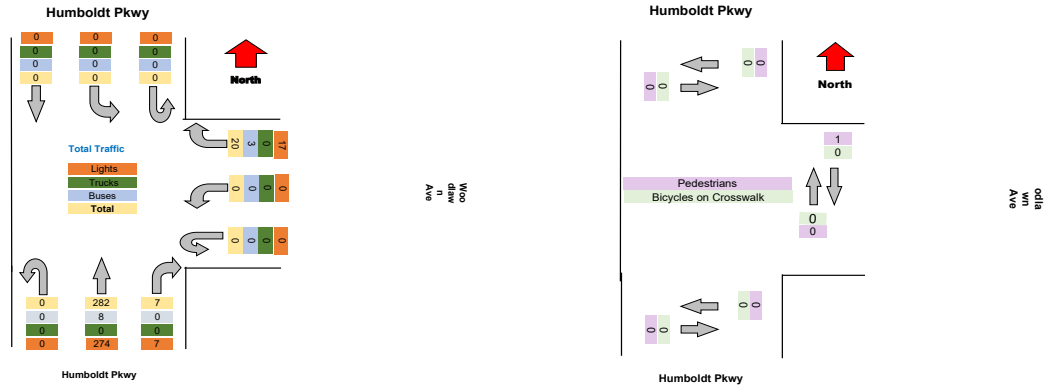



Turning Movement Data Plot

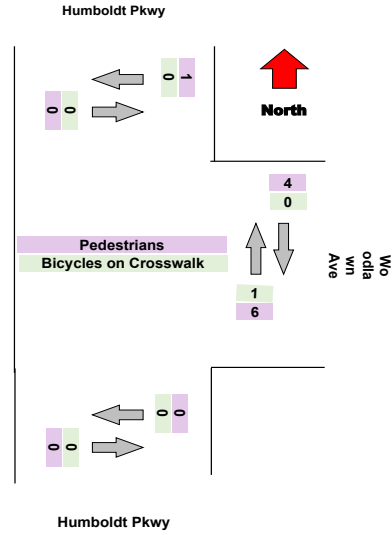
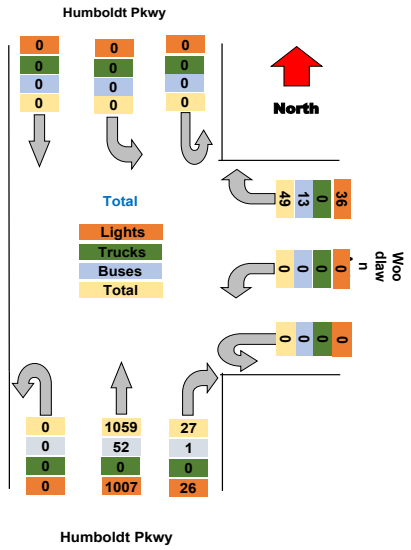

Turning Movement Peak Hour Data (AM)  
 7:30:00 AM

Leg Direction	Humboldt Pkwy Southbound						Woodlawn Ave Westbound						Humboldt Pkwy Northbound						Total
	Thru	Left	U-Turn	App Total	Peds CW	Peds CCW	Right	Left	U-Turn	App Total	Peds CW	Peds CCW	Right	Thru	U-Turn	App Total	Peds CW	Peds CCW	
7:30:00 AM	0	0	0	0	0	0	6	0	0	6	0	1	1	55	0	57	0	0	63
7:45:00 AM	0	0	0	0	0	0	0	0	0	0	0	1	0	74	0	74	0	0	74
8:00:00 AM	0	0	0	0	0	0	2	0	0	2	0	1	5	75	0	81	0	0	83
8:15:00 AM	0	0	0	0	0	0	3	0	0	3	0	0	2	44	0	46	0	0	49
<b>Grand Total</b>	<b>0</b>	<b>0</b>	<b>0</b>	<b>0</b>	<b>0</b>	<b>0</b>	<b>11</b>	<b>0</b>	<b>0</b>	<b>11</b>	<b>0</b>	<b>2</b>	<b>8</b>	<b>248</b>	<b>0</b>	<b>258</b>	<b>0</b>	<b>0</b>	<b>269</b>
% Approach	#####	#####	#####	0.0%	0.0%	0.0%	14.2%	0.0%	0.0%	0.0%	0.0%	0.0%	45.1%	41.7%	0.0%	0.0%	0.0%	0.0%	
% Total	0.0%	0.0%	0.0%	0.0%	0.0%	0.0%	4.1%	0.0%	0.0%	4.1%	0.0%	0.0%	3.0%	92.2%	0.0%	95.9%	0.0%	0.0%	
PHF	0.000	0.000	0.000	0.000	0.000	0.000	0.458	0.000	0.000	0.458	0.000	0.000	0.400	0.827	0.000	0.796	0.000	0.000	0.810
Lights	0	0	0	0	0	0	9	0	0	9	0	0	7	235	0	242	0	0	251
% Lights	0.0%	0.0%	0.0%	0.0%	0.0%	0.0%	81.8%	0.0%	0.0%	81.8%	0.0%	0.0%	87.5%	94.8%	0.0%	93.8%	0.0%	0.0%	93.3%
Trucks	0	0	0	0	0	0	0	0	0	0	0	0	0	0	0	0	0	0	0
% Trucks	0.0%	0.0%	0.0%	0.0%	0.0%	0.0%	0.0%	0.0%	0.0%	0.0%	0.0%	0.0%	0.0%	0.0%	0.0%	0.0%	0.0%	0.0%	0.0%
Buses	0	0	0	0	0	0	2	0	0	2	0	0	1	13	0	14	0	0	16
% Buses	0.0%	0.0%	0.0%	0.0%	0.0%	0.0%	18.2%	0.0%	0.0%	0.0%	0.0%	0.0%	12.5%	5.2%	0.0%	0.0%	0.0%	0.0%	5.9%
Pedestrians	0	0	0	0	0	0	0	0	0	0	2	0	0	0	0	0	0	0	
% Pedestrians	0.0%	0.0%	0.0%	0.0%	0.0%	0.0%	0.0%	0.0%	0.0%	0.0%	100.0%	0.0%	0.0%	0.0%	0.0%	0.0%	0.0%	0.0%	
Bicycles on Crosswalk	0	0	0	0	0	0	0	0	0	0	0	0	0	0	0	0	0	0	
% Bicycles on Crosswalk	0.0%	0.0%	0.0%	0.0%	0.0%	0.0%	0.0%	0.0%	0.0%	0.0%	0.0%	0.0%	0.0%	0.0%	0.0%	0.0%	0.0%	0.0%	0.0%

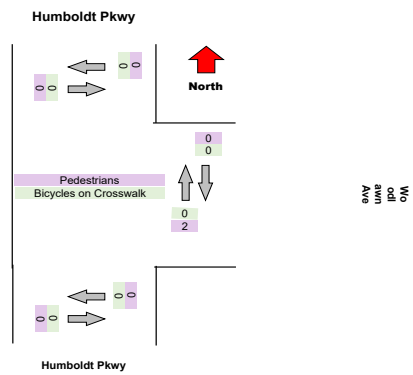
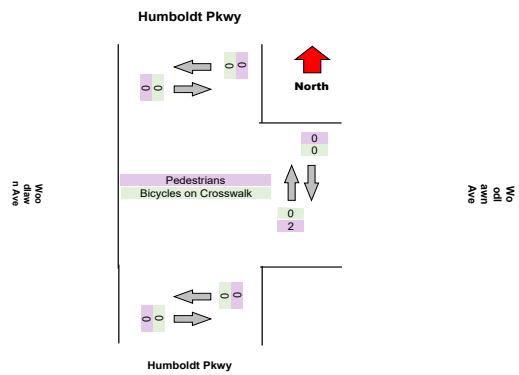
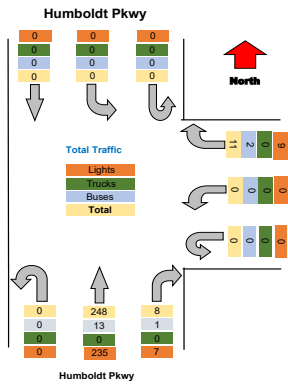

Turning Movement Peak Hour Data (PM)  
 4:30:00 PM

Leg	Humboldt Pkwy						Woodlawn Ave						Humboldt Pkwy						Total
	Southbound						Westbound						Northbound						
Direction	Thru	Left	U-Turn	App Total	Peds CW	Peds CCW	Right	Left	U-Turn	App Total	Peds CW	Peds CCW	Right	Thru	U-Turn	App Total	Peds CW	Peds CCW	
4:30:00 PM	0	0	0	0	0	0	4	0	0	4	1	0	2	85	0	87	0	0	91
4:45:00 PM	0	0	0	0	0	0	5	0	0	5	2	0	2	68	0	70	0	0	75
5:00:00 PM	0	0	0	0	0	1	7	0	0	7	0	2	1	74	0	75	0	0	82
5:15:00 PM	0	0	0	0	0	0	3	0	0	3	0	0	4	87	0	91	0	0	94
<b>Grand Total</b>	<b>0</b>	<b>0</b>	<b>0</b>	<b>0</b>	<b>0</b>	<b>1</b>	<b>19</b>	<b>0</b>	<b>0</b>	<b>19</b>	<b>3</b>	<b>2</b>	<b>9</b>	<b>314</b>	<b>0</b>	<b>323</b>	<b>0</b>	<b>0</b>	<b>342</b>
% Approach	#####	#####	#####	0.0%	0.0%	0.0%	14.2%	0.0%	0.0%	0.0%	0.0%	0.0%	45.1%	41.7%	0.0%	0.0%	0.0%	0.0%	
% Total	0.0%	0.0%	0.0%	0.0%	0.0%	0.0%	5.6%	0.0%	0.0%	5.6%	0.0%	0.0%	2.6%	91.8%	0.0%	94.4%	0.0%	0.0%	
PHF	0.000	0.000	0.000	0.000	0.000	0.000	0.679	0.000	0.000	0.679	0.000	0.000	0.563	0.902	0.000	0.887	0.000	0.000	0.910
Lights	0	0	0	0	0	0	15	0	0	15	0	0	9	302	0	311	0	0	326
% Lights	0.0%	0.0%	0.0%	0.0%	0.0%	0.0%	78.9%	0.0%	0.0%	78.9%	0.0%	0.0%	#####	96.2%	0.0%	96.3%	0.0%	0.0%	95.3%
Trucks	0	0	0	0	0	0	0	0	0	0	0	0	0	0	0	0	0	0	0
% Trucks	0.0%	0.0%	0.0%	0.0%	0.0%	0.0%	0.0%	0.0%	0.0%	0.0%	0.0%	0.0%	0.0%	0.0%	0.0%	0.0%	0.0%	0.0%	0.0%
Buses	0	0	0	0	0	0	4	0	0	4	0	0	0	12	0	12	0	0	16
% Buses	0.0%	0.0%	0.0%	0.0%	0.0%	0.0%	21.1%	0.0%	0.0%	0.0%	0.0%	0.0%	0.0%	3.8%	0.0%	0.0%	0.0%	0.0%	4.7%
Pedestrians	0	0	0	0	0	1	0	0	0	0	3	2	0	0	0	0	0	0	0
% Pedestrians	0.0%	0.0%	0.0%	0.0%	0.0%	100.0%	0.0%	0.0%	0.0%	0.0%	100.0%	100.0%	0.0%	0.0%	0.0%	0.0%	0.0%	0.0%	0.0%
Bicycles on Crosswalk	0	0	0	0	0	0	0	0	0	0	0	0	0	0	0	0	0	0	0
% Bicycles on Crosswalk	0.0%	0.0%	0.0%	0.0%	0.0%	0.0%	0.0%	0.0%	0.0%	0.0%	0.0%	0.0%	0.0%	0.0%	0.0%	0.0%	0.0%	0.0%	0.0%

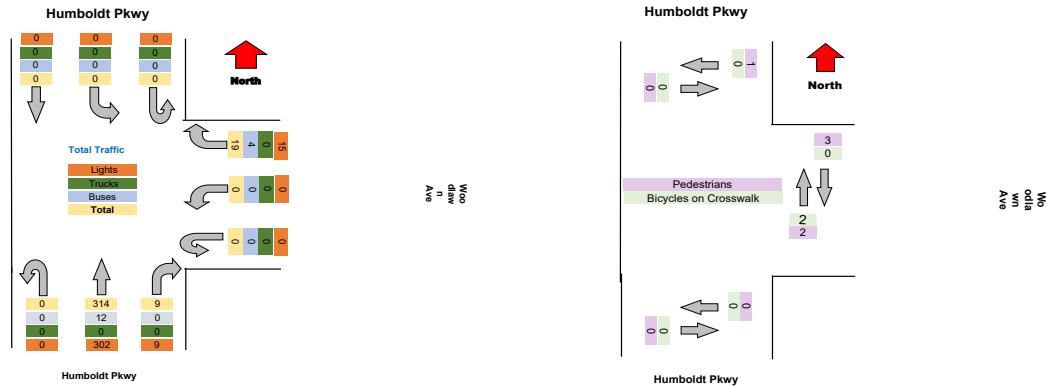





Turning Movement Data Plot

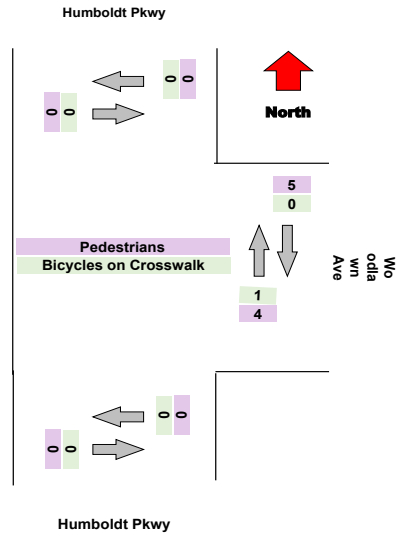
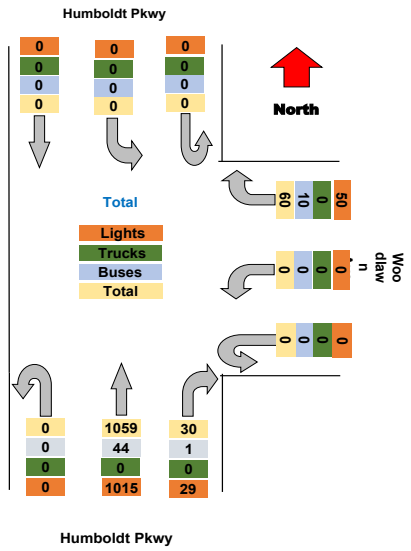

Turning Movement Peak Hour Data (AM)  
 7:30:00 AM

Leg Direction	Humboldt Pkwy						Woodlawn Ave						Humboldt Pkwy						Total
	Southbound						Westbound						Northbound						
Start Time	Thru	Left	U-Turn	App Total	Peds CW	Peds CCW	Right	Left	U-Turn	App Total	Peds CW	Peds CCW	Right	Thru	U-Turn	App Total	Peds CW	Peds CCW	
7:30:00 AM	0	0	0	0	0	0	3	0	0	3	0	1	1	52	0	54	0	0	
7:45:00 AM	0	0	0	0	0	0	5	0	0	5	0	0	1	74	0	75	0	0	
8:00:00 AM	0	0	0	0	0	0	1	0	0	1	0	0	3	76	0	79	0	0	
8:15:00 AM	0	0	0	0	0	0	2	0	0	2	0	0	3	47	0	50	0	0	
<b>Grand Total</b>	<b>0</b>	<b>0</b>	<b>0</b>	<b>0</b>	<b>0</b>	<b>0</b>	<b>11</b>	<b>0</b>	<b>0</b>	<b>11</b>	<b>0</b>	<b>1</b>	<b>8</b>	<b>249</b>	<b>0</b>	<b>258</b>	<b>0</b>	<b>0</b>	
% Approach	#####	#####	#####	0.0%	0.0%	0.0%	14.2%	0.0%	0.0%	0.0%	0.0%	0.0%	45.1%	41.7%	0.0%	0.0%	0.0%	0.0%	
% Total	0.0%	0.0%	0.0%	0.0%	0.0%	0.0%	4.1%	0.0%	0.0%	4.1%	0.0%	0.0%	3.0%	92.6%	0.0%	95.9%	0.0%	0.0%	
PHF	0.000	0.000	0.000	0.000	0.000	0.000	0.550	0.000	0.000	0.550	0.000	0.000	0.667	0.819	0.000	0.816	0.000	0.000	
Lights	0	0	0	0	0	0	10	0	0	10	0	0	7	235	0	242	0	0	
% Lights	0.0%	0.0%	0.0%	0.0%	0.0%	0.0%	90.9%	0.0%	0.0%	90.9%	0.0%	0.0%	87.5%	94.4%	0.0%	93.8%	0.0%	0.0%	
Trucks	0	0	0	0	0	0	0	0	0	0	0	0	0	0	0	0	0	0	
% Trucks	0.0%	0.0%	0.0%	0.0%	0.0%	0.0%	0.0%	0.0%	0.0%	0.0%	0.0%	0.0%	0.0%	0.0%	0.0%	0.0%	0.0%	0.0%	
Buses	0	0	0	0	0	0	1	0	0	1	0	0	1	14	0	15	0	0	
% Buses	0.0%	0.0%	0.0%	0.0%	0.0%	0.0%	9.1%	0.0%	0.0%	9.1%	0.0%	0.0%	12.5%	5.6%	0.0%	5.8%	0.0%	0.0%	
Pedestrians	0	0	0	0	0	0	0	0	0	0	0	1	0	0	0	0	0	0	
% Pedestrians	0.0%	0.0%	0.0%	0.0%	0.0%	0.0%	0.0%	0.0%	0.0%	0.0%	0.0%	100.0%	0.0%	0.0%	0.0%	0.0%	0.0%	0.0%	
Bicycles on Crosswalk	0	0	0	0	0	0	0	0	0	0	0	0	0	0	0	0	0	0	
% Bicycles on Crosswalk	0.0%	0.0%	0.0%	0.0%	0.0%	0.0%	0.0%	0.0%	0.0%	0.0%	0.0%	0.0%	0.0%	0.0%	0.0%	0.0%	0.0%	0.0%	

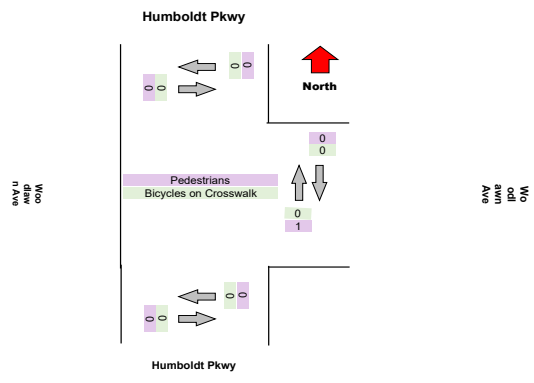
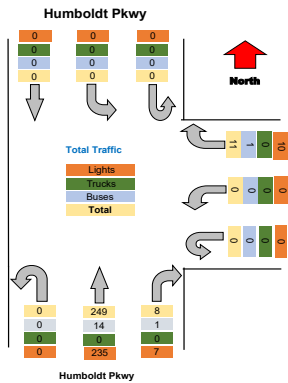

Turning Movement Peak Hour Data (PM)  
 4:30:00 PM

Leg	Humboldt Pkwy						Woodlawn Ave						Humboldt Pkwy						Total							
	Southbound						Westbound						Northbound													
Direction	Thru	Left	U-Turn	App	Total		Right	Left	U-Turn	App	Total	Peds	CW	Peds	CCW	Right	Thru	U-Turn	App	Total	Peds	CW	Peds	CCW		
4:30:00 PM	0	0	0	0	0	0	3	0	0	3	0	0	2	78	0	80	0	0	0	80	0	0	0	0	0	83
4:45:00 PM	0	0	0	0	0	0	9	0	0	9	0	0	1	74	0	75	0	0	0	75	0	0	0	0	0	84
5:00:00 PM	0	0	0	0	0	0	4	0	0	4	2	1	0	82	0	82	0	0	0	82	0	0	0	0	0	86
5:15:00 PM	0	0	0	0	0	0	3	0	0	3	1	1	0	84	0	84	0	0	0	84	0	0	0	0	0	87
<b>Grand Total</b>	<b>0</b>	<b>0</b>	<b>0</b>	<b>0</b>	<b>0</b>	<b>0</b>	<b>19</b>	<b>0</b>	<b>0</b>	<b>19</b>	<b>3</b>	<b>2</b>	<b>3</b>	<b>318</b>	<b>0</b>	<b>321</b>	<b>0</b>	<b>0</b>	<b>0</b>	<b>321</b>	<b>0</b>	<b>0</b>	<b>0</b>	<b>0</b>	<b>340</b>	
% Approach	#####	#####	#####	0.0%	0.0%	0.0%	14.2%	0.0%	0.0%	0.0%	0.0%	0.0%	45.1%	41.7%	0.0%	0.0%	0.0%	0.0%	0.0%	0.0%	0.0%	0.0%	0.0%	0.0%	0.0%	
% Total	0.0%	0.0%	0.0%	0.0%	0.0%	0.0%	5.6%	0.0%	0.0%	5.6%	0.0%	0.0%	0.9%	93.5%	0.0%	94.4%	0.0%	0.0%	0.0%	0.0%	0.0%	0.0%	0.0%	0.0%	0.0%	
PHF	0.000	0.000	0.000	0.000	0.000	0.000	0.528	0.000	0.000	0.528	0.000	0.000	0.375	0.946	0.000	0.955	0.000	0.000	0.000	0.000	0.000	0.000	0.000	0.000	0.000	0.977
Lights	0	0	0	0	0	0	17	0	0	17	0	0	3	308	0	311	0	0	0	0	0	0	0	0	0	328
% Lights	0.0%	0.0%	0.0%	0.0%	0.0%	0.0%	89.5%	0.0%	0.0%	89.5%	0.0%	0.0%	100.0%	96.9%	0.0%	96.9%	0.0%	0.0%	0.0%	0.0%	0.0%	0.0%	0.0%	0.0%	0.0%	96.5%
Trucks	0	0	0	0	0	0	0	0	0	0	0	0	0	0	0	0	0	0	0	0	0	0	0	0	0	0
% Trucks	0.0%	0.0%	0.0%	0.0%	0.0%	0.0%	0.0%	0.0%	0.0%	0.0%	0.0%	0.0%	0.0%	0.0%	0.0%	0.0%	0.0%	0.0%	0.0%	0.0%	0.0%	0.0%	0.0%	0.0%	0.0%	0.0%
Buses	0	0	0	0	0	0	2	0	0	2	0	0	0	10	0	10	0	0	0	0	0	0	0	0	0	12
% Buses	0.0%	0.0%	0.0%	0.0%	0.0%	0.0%	10.5%	0.0%	0.0%	10.5%	0.0%	0.0%	0.0%	3.1%	0.0%	3.1%	0.0%	0.0%	0.0%	0.0%	0.0%	0.0%	0.0%	0.0%	0.0%	3.5%
Pedestrians	0	0	0	0	0	0	0	0	0	0	3	1	0	0	0	0	0	0	0	0	0	0	0	0	0	0
% Pedestrians	0.0%	0.0%	0.0%	0.0%	0.0%	0.0%	0.0%	0.0%	0.0%	0.0%	100.0%	50.0%	0.0%	0.0%	0.0%	0.0%	0.0%	0.0%	0.0%	0.0%	0.0%	0.0%	0.0%	0.0%	0.0%	0.0%
Bicycles on Crosswalk	0	0	0	0	0	0	0	0	0	0	0	1	0	0	0	0	0	0	0	0	0	0	0	0	0	0
% Bicycles on Crosswalk	0.0%	0.0%	0.0%	0.0%	0.0%	0.0%	0.0%	0.0%	0.0%	0.0%	0.0%	50.0%	0.0%	0.0%	0.0%	0.0%	0.0%	0.0%	0.0%	0.0%	0.0%	0.0%	0.0%	0.0%	0.0%	0.0%

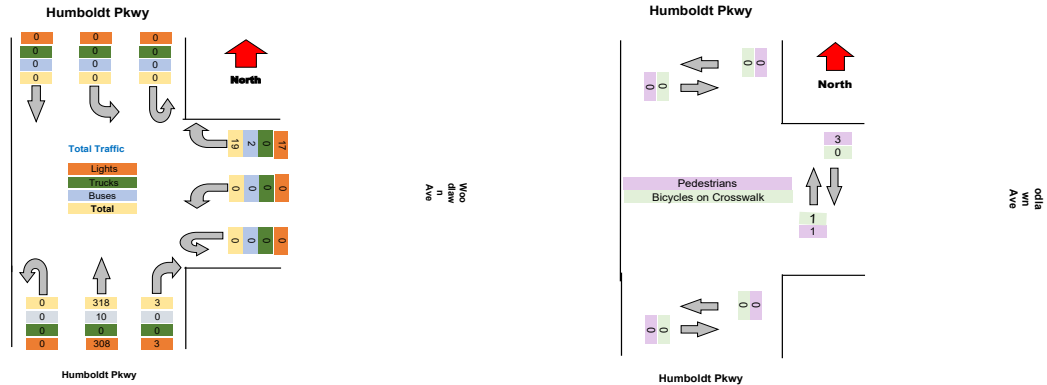



Turning Movement Data Plot

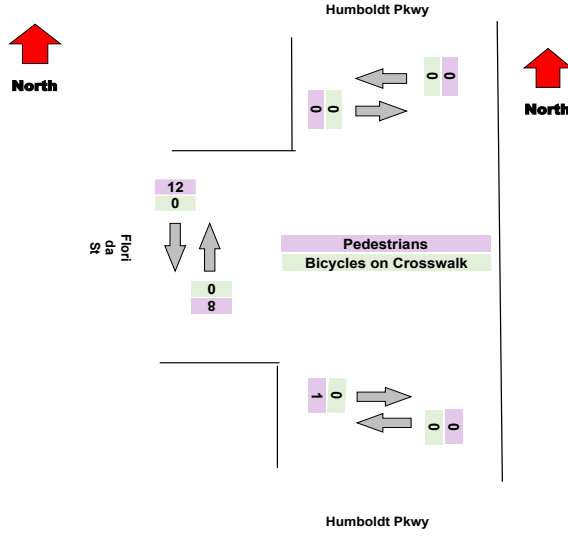
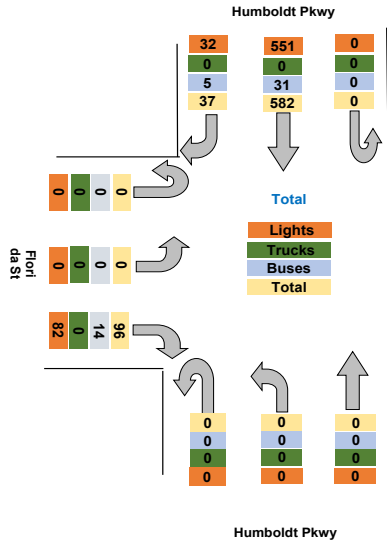

Turning Movement Peak Hour Data (AM)

7:30:00 AM

Leg Direction	Humboldt Pkwy Southbound						Humboldt Pkwy NorthBound						Florida St Eastbound					
	Right	Thru	U-Turn	App Total	Peds CW	Peds CCW	Thru	Left	U-Turn	App Total	Peds CW	Peds CCW	Right	Left	U-Turn	App Total	Peds CW	Peds CCW
7:30:00 AM	2	30	0	32	0	0	0	0	0	0	0	0	9	0	0	9	1	0
7:45:00 AM	0	26	0	26	0	0	0	0	0	0	0	0	6	0	0	6	1	0
8:00:00 AM	2	34	0	36	0	0	0	0	0	0	0	0	3	0	0	3	0	1
8:15:00 AM	3	38	0	41	0	0	0	0	0	0	1	0	3	0	0	4	1	0
<b>Grand Total</b>	7	128	0	135	0	0	0	0	0	0	1	0	21	0	0	22	3	1
% Approach	5.2%	94.8%	0.0%	0.0%	0.0%	0.0%	14.2%	0.0%	0.0%	0.0%	0.0%	0.0%	45.1%	41.7%	0.0%	0.0%	0.0%	0.0%
% Total	4.5%	81.5%	0.0%	86.0%	0.0%	0.0%	0.0%	0.0%	0.0%	0.0%	0.0%	0.0%	13.4%	0.0%	0.0%	14.0%	0.0%	0.0%
PHF	0.583	0.842	0.000	0.823	0.000	0.000	0.000	0.000	0.000	0.000	0.000	0.000	0.583	0.000	0.000	0.611	0.000	0.000
Lights	7	122	0	129	0	0	0	0	0	0	0	0	17	0	0	17	0	0
% Lights	100.0%	95.3%	0.0%	95.6%	0.0%	0.0%	0.0%	0.0%	0.0%	0.0%	0.0%	0.0%	81.0%	0.0%	0.0%	77.3%	0.0%	0.0%
Trucks	0	0	0	0	0	0	0	0	0	0	0	0	0	0	0	0	0	0
% Trucks	0.0%	0.0%	0.0%	0.0%	0.0%	0.0%	0.0%	0.0%	0.0%	0.0%	0.0%	0.0%	0.0%	0.0%	0.0%	0.0%	0.0%	0.0%
Buses	0	6	0	6	0	0	0	0	0	0	0	0	4	0	0	4	0	0
% Buses	0.0%	4.7%	0.0%	0.0%	0.0%	0.0%	0.0%	0.0%	0.0%	0.0%	0.0%	0.0%	19.0%	0.0%	0.0%	0.0%	0.0%	0.0%
Pedestrians	0	0	0	0	0	0	0	0	0	0	1	0	0	0	0	0	3	1
% Pedestrians	0.0%	0.0%	0.0%	0.0%	0.0%	0.0%	0.0%	0.0%	0.0%	0.0%	100.0%	0.0%	0.0%	0.0%	0.0%	0.0%	100.0%	100.0%
Bicycles on Crosswalk	0	0	0	0	0	0	0	0	0	0	0	0	0	0	0	0	0	0
% Bicycles on Crosswalk	0.0%	0.0%	0.0%	0.0%	0.0%	0.0%	0.0%	0.0%	0.0%	0.0%	0.0%	0.0%	0.0%	0.0%	0.0%	0.0%	0.0%	0.0%

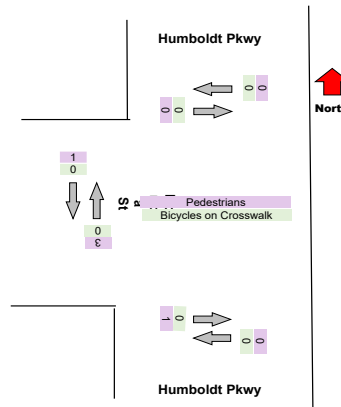
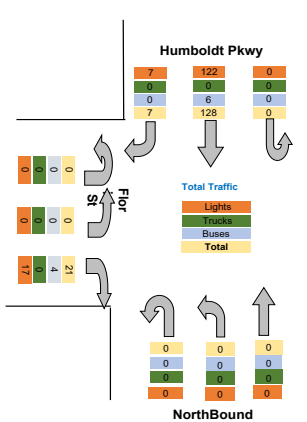

Turning Movement Peak Hour Data (PM)  
 4:30:00 PM

Leg Direction	Humboldt Pkwy Southbound						Humboldt Pkwy NorthBound						Florida St Eastbound									
	Right	Thru	U-Turn	App	Total	Peds CW	Peds CCW	Thru	Left	U-Turn	App	Total	Peds CW	Peds CCW	Right	Left	U-Turn	App	Total	Peds CW	Peds CCW	
4:30:00 PM	5	55	0		60	0	0	0	0	0	0	0	0	0	8	0	0		8	1	1	
4:45:00 PM	4	45	0		49	0	0	0	0	0	0	0	0	0	12	0	0		12	0	1	
5:00:00 PM	4	50	0		54	0	0	0	0	0	0	0	0	0	9	0	0		9	0	0	
5:15:00 PM	2	39	0		41	0	0	0	0	0	0	0	0	0	6	0	0		6	0	0	
<b>Grand Total</b>	15	189	0		204	0	0	0	0	0	0	0	0	0	35	0	0		35	1	2	
% Approach	7.4%	92.6%	0.0%		0.0%	0.0%	0.0%	14.2%	0.0%	0.0%	0.0%	0.0%	0.0%	0.0%	45.1%	41.7%	0.0%		0.0%	0.0%	0.0%	
% Total	6.3%	79.1%	0.0%		85.4%	0.0%	0.0%	0.0%	0.0%	0.0%	0.0%	0.0%	0.0%	0.0%	14.6%	0.0%	0.0%		14.6%	0.0%	0.0%	
PHF	0.750	0.859	0.000		0.850	0.000	0.000	0.000	0.000	0.000	0.000	0.000	0.000	0.000	0.729	0.000	0.000		0.729	0.000	0.000	
Lights	11	184	0		195	0	0	0	0	0	0	0	0	0	32	0	0		32	0	0	
% Lights	73.3%	97.4%	0.0%		95.6%	0.0%	0.0%	0.0%	0.0%	0.0%	0.0%	0.0%	0.0%	0.0%	91.4%	0.0%	0.0%		91.4%	0.0%	0.0%	
Trucks	0	0	0		0	0	0	0	0	0	0	0	0	0	0	0	0		0	0	0	
% Trucks	0.0%	0.0%	0.0%		0.0%	0.0%	0.0%	0.0%	0.0%	0.0%	0.0%	0.0%	0.0%	0.0%	0.0%	0.0%	0.0%		0.0%	0.0%	0.0%	
Buses	4	5	0		9	0	0	0	0	0	0	0	0	0	3	0	0		3	0	0	
% Buses	26.7%	2.6%	0.0%		0.0%	0.0%	0.0%	0.0%	0.0%	0.0%	0.0%	0.0%	0.0%	0.0%	8.6%	0.0%	0.0%		0.0%	0.0%	0.0%	
Pedestrians	0	0	0		0	0	0	0	0	0	0	0	0	0	0	0	0		0	1	2	
% Pedestrians	0.0%	0.0%	0.0%		0.0%	0.0%	0.0%	0.0%	0.0%	0.0%	0.0%	0.0%	0.0%	0.0%	0.0%	0.0%	0.0%		0.0%	100.0%	100.0%	
Bicycles on Crosswalk	0	0	0		0	0	0	0	0	0	0	0	0	0	0	0	0		0	0	0	
% Bicycles on Crosswalk	0.0%	0.0%	0.0%		0.0%	0.0%	0.0%	0.0%	0.0%	0.0%	0.0%	0.0%	0.0%	0.0%	0.0%	0.0%	0.0%		0.0%	0.0%	0.0%	

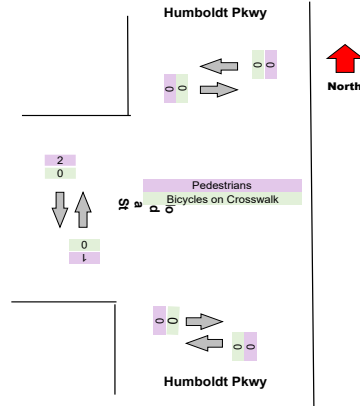
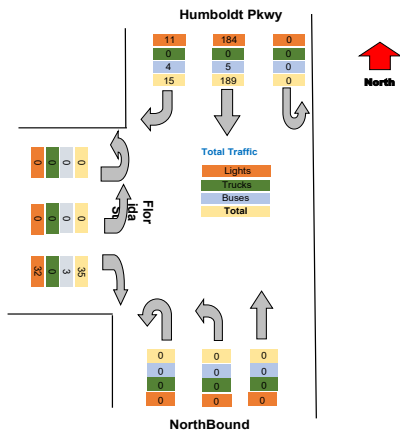



Intersection: Elm St Pine St  
 Location: Kennett Square, PA  
 Site: 01  
 Survey Date: Wednesday, 04-28-2021  
 GPS: 42.948550, -72.790034



<b>Total</b>
15
25
40
18
38
41
32
129
39
45
84
73
73
68
61
275
63
47
37
41
188
716
0.0%
0.0%
665
92.9%
0
0.0%
50
7.0%
0
0.0%
0.0%

Intersection: Elm St Pine St  
Location: Kennett Square, PA  
Site: 01  
Survey Date: Wednesday, 04-28-2021  
GPS: 42.948550, -72.790034

Total
41
32
39
45
157
0.872
146
93.0%
0
0.0%
10
6.4%
0
0.0%
0
0.0%

Intersection: Elm St Pine St  
Location: Kennett Square, PA  
Site: 01  
Survey Date: Wednesday, 04-28-2021  
GPS: 42.948550, -72.790034



Total
68
61
63
47
239
0.879
227
95.0%
0
0.0%
12
5.0%
0
0.0%
0
0.0%



Turning Movement Data Plot

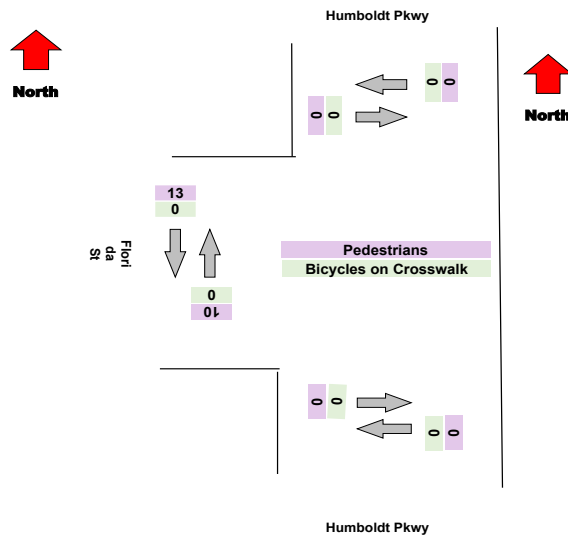
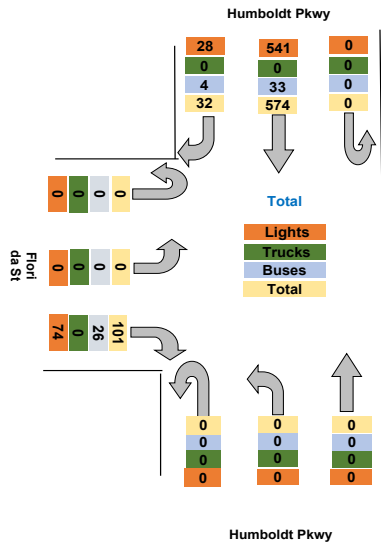

Turning Movement Peak Hour Data (AM)

7:30:00 AM

Leg Direction	Humboldt Pkwy Southbound						Humboldt Pkwy NorthBound						Florida St Eastbound						Total					
	Right	Thru	U-Turn	App	Total	Peds CW	Peds CCW	Thru	Left	U-Turn	App	Total	Peds CW	Peds CCW	Right	Left	U-Turn	App		Total	Peds CW	Peds CCW		
7:30:00 AM	0	29	0	29	0	0	0	0	0	0	0	0	0	0	7	0	0	7	1	0	0	0	36	
7:45:00 AM	0	37	0	37	0	0	0	0	0	0	0	0	0	0	2	0	0	2	0	0	1	0	39	
8:00:00 AM	3	29	0	32	0	0	0	0	0	0	0	0	0	0	5	0	0	5	3	0	0	0	37	
8:15:00 AM	3	29	0	32	0	0	0	0	0	0	0	0	0	0	8	0	0	8	0	0	0	0	40	
<b>Grand Total</b>	6	124	0	130	0	0	0	0	0	0	0	0	0	0	22	0	0	22	4	1	0	0	152	
% Approach	4.6%	95.4%	0.0%	0.0%	0.0%	0.0%	14.2%	0.0%	0.0%	0.0%	0.0%	0.0%	0.0%	0.0%	45.1%	41.7%	0.0%	0.0%	0.0%	0.0%	0.0%	0.0%	0.0%	
% Total	3.9%	81.6%	0.0%	85.5%	0.0%	0.0%	0.0%	0.0%	0.0%	0.0%	0.0%	0.0%	0.0%	0.0%	14.5%	0.0%	0.0%	14.5%	0.0%	0.0%	0.0%	0.0%	0.0%	
PHF	0.500	0.838	0.000	0.878	0.000	0.000	0.000	0.000	0.000	0.000	0.000	0.000	0.000	0.000	0.688	0.000	0.000	0.688	0.000	0.000	0.000	0.000	0.000	0.950
Lights	4	117	0	121	0	0	0	0	0	0	0	0	0	0	17	0	0	17	0	0	0	0	0	138
% Lights	66.7%	94.4%	0.0%	93.1%	0.0%	0.0%	0.0%	0.0%	0.0%	0.0%	0.0%	0.0%	0.0%	0.0%	77.3%	0.0%	0.0%	77.3%	0.0%	0.0%	0.0%	0.0%	0.0%	90.8%
Trucks	0	0	0	0	0	0	0	0	0	0	0	0	0	0	0	0	0	0	0	0	0	0	0	0
% Trucks	0.0%	0.0%	0.0%	0.0%	0.0%	0.0%	0.0%	0.0%	0.0%	0.0%	0.0%	0.0%	0.0%	0.0%	0.0%	0.0%	0.0%	0.0%	0.0%	0.0%	0.0%	0.0%	0.0%	0.0%
Buses	2	7	0	9	0	0	0	0	0	0	0	0	0	0	5	0	0	5	0	0	0	0	0	14
% Buses	33.3%	5.6%	0.0%	0.0%	0.0%	0.0%	0.0%	0.0%	0.0%	0.0%	0.0%	0.0%	0.0%	0.0%	22.7%	0.0%	0.0%	0.0%	0.0%	0.0%	0.0%	0.0%	0.0%	9.2%
Pedestrians	0	0	0	0	0	0	0	0	0	0	0	0	0	0	0	0	0	0	0	4	1	0	0	0
% Pedestrians	0.0%	0.0%	0.0%	0.0%	0.0%	0.0%	0.0%	0.0%	0.0%	0.0%	0.0%	0.0%	0.0%	0.0%	0.0%	0.0%	0.0%	0.0%	0.0%	100.0%	100.0%	0.0%	0.0%	0.0%
Bicycles on Crosswalk	0	0	0	0	0	0	0	0	0	0	0	0	0	0	0	0	0	0	0	0	0	0	0	0
% Bicycles on Crosswalk	0.0%	0.0%	0.0%	0.0%	0.0%	0.0%	0.0%	0.0%	0.0%	0.0%	0.0%	0.0%	0.0%	0.0%	0.0%	0.0%	0.0%	0.0%	0.0%	0.0%	0.0%	0.0%	0.0%	0.0%

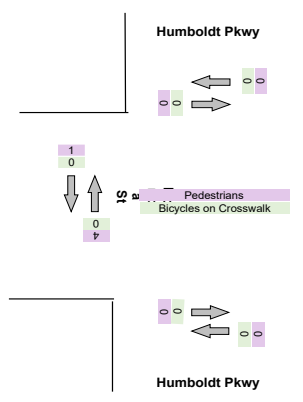
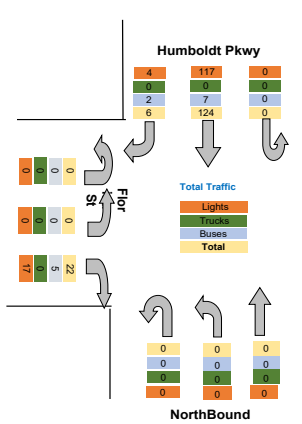

Turning Movement Peak Hour Data (PM)

4:30:00 PM

Leg Direction	Humboldt Pkwy Southbound						Humboldt Pkwy NorthBound						Florida St Eastbound						Total
	Right	Thru	U-Turn	App Total	Peds CW	Peds CCW	Thru	Left	U-Turn	App Total	Peds CW	Peds CCW	Right	Left	U-Turn	App Total	Peds CW	Peds CCW	
4:30:00 PM	1	51	0	52	0	0	0	0	0	0	0	0	6	0	0	6	1	5	58
4:45:00 PM	2	45	0	47	0	0	0	0	0	0	0	0	10	0	0	10	1	2	57
5:00:00 PM	4	40	0	44	0	0	0	0	0	0	0	0	15	0	0	15	1	1	59
5:15:00 PM	3	42	0	45	0	0	0	0	0	0	0	0	4	0	0	4	0	0	49
<b>Grand Total</b>	10	178	0	188	0	0	0	0	0	0	0	0	35	0	0	35	3	8	223
% Approach	5.3%	94.7%	0.0%	0.0%	0.0%	0.0%	14.2%	0.0%	0.0%	0.0%	0.0%	0.0%	45.1%	41.7%	0.0%	0.0%	0.0%	0.0%	0.0%
% Total	4.5%	79.8%	0.0%	84.3%	0.0%	0.0%	0.0%	0.0%	0.0%	0.0%	0.0%	0.0%	15.7%	0.0%	0.0%	15.7%	0.0%	0.0%	0.0%
PHF	0.625	0.873	0.000	0.904	0.000	0.000	0.000	0.000	0.000	0.000	0.000	0.000	0.583	0.000	0.000	0.583	0.000	0.000	0.945
Lights	9	173	0	182	0	0	0	0	0	0	0	0	28	0	0	28	0	0	210
% Lights	90.0%	97.2%	0.0%	96.8%	0.0%	0.0%	0.0%	0.0%	0.0%	0.0%	0.0%	0.0%	80.0%	0.0%	0.0%	80.0%	0.0%	0.0%	94.2%
Trucks	0	0	0	0	0	0	0	0	0	0	0	0	0	0	0	0	0	0	0
% Trucks	0.0%	0.0%	0.0%	0.0%	0.0%	0.0%	0.0%	0.0%	0.0%	0.0%	0.0%	0.0%	0.0%	0.0%	0.0%	0.0%	0.0%	0.0%	0.0%
Buses	1	5	0	6	0	0	0	0	0	0	0	0	0	0	0	0	0	0	12
% Buses	10.0%	2.8%	0.0%	0.0%	0.0%	0.0%	0.0%	0.0%	0.0%	0.0%	0.0%	0.0%	17.1%	0.0%	0.0%	0.0%	0.0%	0.0%	5.4%
Pedestrians	0	0	0	0	0	0	0	0	0	0	0	0	0	0	0	0	3	8	0
% Pedestrians	0.0%	0.0%	0.0%	0.0%	0.0%	0.0%	0.0%	0.0%	0.0%	0.0%	0.0%	0.0%	0.0%	0.0%	0.0%	0.0%	100.0%	100.0%	0.0%
Bicycles on Crosswalk	0	0	0	0	0	0	0	0	0	0	0	0	0	0	0	0	0	0	0
% Bicycles on Crosswalk	0.0%	0.0%	0.0%	0.0%	0.0%	0.0%	0.0%	0.0%	0.0%	0.0%	0.0%	0.0%	0.0%	0.0%	0.0%	0.0%	0.0%	0.0%	0.0%

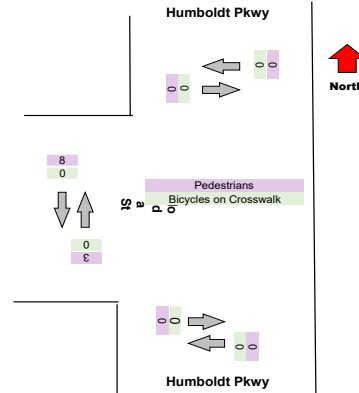
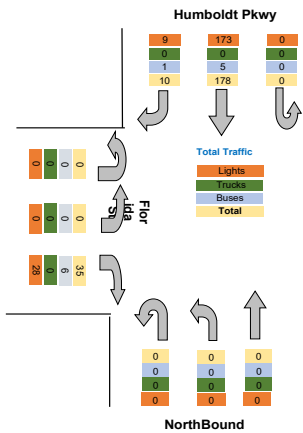

Intersection: Elm St Pine St  
 Location: Kennett Square, PA  
 Site: 01  
 Survey Date: Wednesday, 04-28-2021  
 GPS: 42.948550, -72.790034



TSTData.com

Project	Labella
Project Code	Labella
Site Name	J
Legs and Movements	All Processed Legs & Movement
Bin Size	15 minutes
Survey Date	2021-10-28, Thursday
Location	J
Latitude and Longitude	42.920093, -78.843735

	Start	End	PHF
Forced Peak AM	2021/10/28 07:30:00	2021/10/28 08:30:00	0.94
Forced Peak PM	2021/10/28 16:30:00	2021/10/28 17:30:00	0.95
AM Peak	2021/10/28 07:30:00	2021/10/28 08:30:00	0.94
PM Peak	2021/10/28 16:30:00	2021/10/28 17:30:00	0.95

Turning Movement Data

Leg Direction	Humboldt Pkwy Southbound						Humboldt Pkwy Northbound						Florida St Eastbound						Total
	Right	Thru	U-Turn	App Total	Peds CW	Peds CCW	Thru	Left	U-Turn	App Total	Peds CW	Peds CCW	Right	Left	U-Turn	App Total	Peds CW	Peds CCW	
Start Time																			
6:30:00 AM	0	14	0	14	0	0	0	0	0	0	0	0	3	0	0	3	0	0	17
6:45:00 AM	1	15	0	16	0	0	0	0	0	0	0	0	3	0	0	3	0	0	19
Hourly Total	1	29	0	30	0	0	0	0	0	0	0	0	6	0	0	6	0	0	36
7:00:00 AM	2	20	0	22	0	0	0	0	0	0	0	0	3	0	0	3	0	0	25
7:15:00 AM	0	14	0	14	0	0	0	0	0	0	0	0	8	0	0	8	1	0	22
7:30:00 AM	1	31	0	32	0	0	0	0	0	0	0	1	7	0	0	8	1	0	40
7:45:00 AM	2	35	0	37	0	0	0	0	0	0	0	0	6	0	0	6	0	0	43
Hourly Total	5	100	0	105	0	0	0	0	0	0	0	1	24	0	0	25	2	0	130
8:00:00 AM	2	36	0	38	0	0	0	0	0	0	0	0	6	0	0	6	0	0	44
8:15:00 AM	5	33	0	38	0	0	0	0	0	0	0	0	8	0	0	8	0	0	46
Hourly Total	7	69	0	76	0	0	0	0	0	0	0	0	14	0	0	14	0	0	90
4:00:00 PM	3	40	0	43	0	0	0	0	0	0	0	0	7	0	0	7	0	5	50
4:15:00 PM	3	41	0	44	0	0	0	0	0	0	0	0	10	0	0	10	1	0	54
4:30:00 PM	3	48	0	51	0	0	0	0	0	0	0	0	14	0	0	14	0	1	65
4:45:00 PM	3	49	0	52	0	0	0	0	0	0	0	0	11	0	0	11	1	1	63
Hourly Total	12	178	0	190	0	0	0	0	0	0	0	0	42	0	0	42	2	7	232
5:00:00 PM	4	49	0	53	0	0	0	0	0	0	0	0	7	0	0	7	0	0	60
5:15:00 PM	0	48	0	48	0	0	0	0	0	0	0	0	11	0	0	11	0	0	59
5:30:00 PM	3	41	0	44	0	0	0	0	0	0	0	0	4	0	0	4	0	1	48
5:45:00 PM	2	43	0	45	0	0	0	0	0	0	0	0	6	0	0	6	0	0	51
Hourly Total	9	181	0	190	0	0	0	0	0	0	0	0	28	0	0	28	0	1	218
Grand Total	34	557	0	591	0	0	0	0	0	0	0	1	114	0	0	115	4	8	706
% Approach	5.8%	94.2%	0.0%	0.0%	0.0%	0.0%	0.0%	0.0%	0.0%	0.0%	0.0%	0.0%	99.1%	0.0%	0.0%	0.0%	0.0%	0.0%	0.0%
% Total	4.8%	78.9%	0.0%	83.7%	0.0%	0.0%	0.0%	0.0%	0.0%	0.0%	0.0%	0.0%	16.1%	0.0%	0.0%	16.3%	0.0%	0.0%	0.0%
Lights	28	531	0	559	0	0	0	0	0	0	0	0	94	0	0	94	0	0	653
% Lights	82.4%	95.3%	0.0%	94.6%	0.0%	0.0%	0.0%	0.0%	0.0%	0.0%	0.0%	0.0%	82.5%	0.0%	0.0%	81.7%	0.0%	0.0%	92.5%
Trucks	0	1	0	1	0	0	0	0	0	0	0	0	0	0	0	0	0	0	1
% Trucks	0.0%	0.2%	0.0%	0.2%	0.0%	0.0%	0.0%	0.0%	0.0%	0.0%	0.0%	0.0%	0.0%	0.0%	0.0%	0.0%	0.0%	0.0%	0.1%
Buses	6	24	0	30	0	0	0	0	0	0	0	0	19	0	0	19	0	0	49
% Buses	17.6%	4.3%	0.0%	0.0%	0.0%	0.0%	0.0%	0.0%	0.0%	0.0%	0.0%	0.0%	16.7%	0.0%	0.0%	0.0%	0.0%	0.0%	6.9%
Pedestrians	0	0	0	0	0	0	0	0	0	0	1	0	0	0	0	0	4	7	0
% Pedestrians	0.0%	0.0%	0.0%	0.0%	0.0%	0.0%	0.0%	0.0%	0.0%	0.0%	100.0%	0.0%	0.0%	0.0%	0.0%	0.0%	100.0%	87.5%	0.0%
% Bicycles on Crosswalk	0.0%	0.0%	0.0%	0.0%	0.0%	0.0%	0.0%	0.0%	0.0%	0.0%	0.0%	0.0%	0.0%	0.0%	0.0%	0.0%	0.0%	12.5%	0.0%



Turning Movement Data Plot

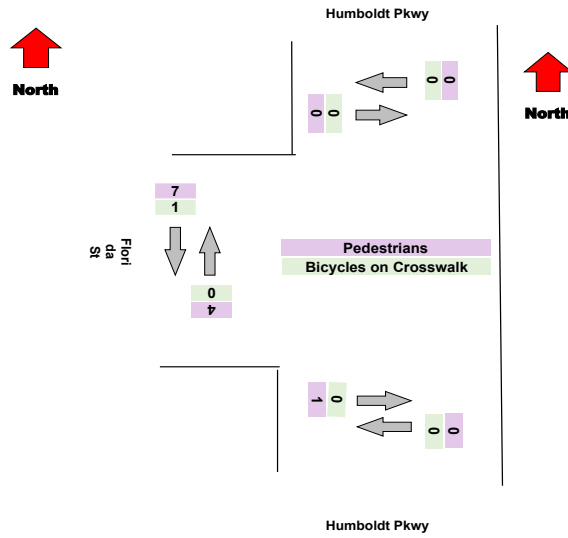
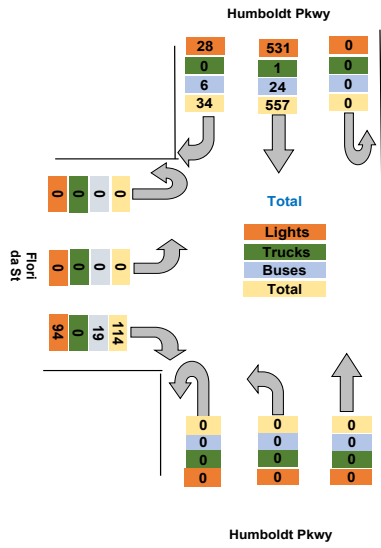

Turning Movement Peak Hour Data (AM)

7:30:00 AM

Leg Direction	Humboldt Pkwy Southbound						Humboldt Pkwy NorthBound						Florida St Eastbound						Total				
	Right	Thru	U-Turn	App	Total	Peds CW	Peds CCW	Thru	Left	U-Turn	App	Total	Peds CW	Peds CCW	Right	Left	U-Turn	App		Total	Peds CW	Peds CCW	
7:30:00 AM	1	31	0	32	0	0	0	0	0	0	0	0	0	1	7	0	0	8	1	0	0	0	40
7:45:00 AM	2	35	0	37	0	0	0	0	0	0	0	0	0	0	6	0	0	6	0	0	0	0	43
8:00:00 AM	2	36	0	38	0	0	0	0	0	0	0	0	0	0	6	0	0	6	0	0	0	0	44
8:15:00 AM	5	33	0	38	0	0	0	0	0	0	0	0	0	0	8	0	0	8	0	0	0	0	46
<b>Grand Total</b>	10	135	0	145	0	0	0	0	0	0	0	0	1	27	0	0	28	1	0	0	0	0	173
% Approach	6.9%	93.1%	0.0%	0.0%	0.0%	0.0%	14.2%	0.0%	0.0%	0.0%	0.0%	0.0%	0.0%	45.1%	41.7%	0.0%	0.0%	0.0%	0.0%	0.0%	0.0%	0.0%	0.0%
% Total	5.8%	78.0%	0.0%	83.8%	0.0%	0.0%	0.0%	0.0%	0.0%	0.0%	0.0%	0.0%	0.0%	15.6%	0.0%	0.0%	16.2%	0.0%	0.0%	0.0%	0.0%	0.0%	0.0%
PHF	0.500	0.938	0.000	0.954	0.000	0.000	0.000	0.000	0.000	0.000	0.000	0.000	0.000	0.844	0.000	0.000	0.875	0.000	0.000	0.000	0.000	0.000	0.940
Lights	8	129	0	137	0	0	0	0	0	0	0	0	0	23	0	0	23	0	0	0	0	0	160
% Lights	80.0%	95.6%	0.0%	94.5%	0.0%	0.0%	0.0%	0.0%	0.0%	0.0%	0.0%	0.0%	0.0%	85.2%	0.0%	0.0%	82.1%	0.0%	0.0%	0.0%	0.0%	0.0%	92.5%
Trucks	0	1	0	1	0	0	0	0	0	0	0	0	0	0	0	0	0	0	0	0	0	0	1
% Trucks	0.0%	0.7%	0.0%	0.7%	0.0%	0.0%	0.0%	0.0%	0.0%	0.0%	0.0%	0.0%	0.0%	0.0%	0.0%	0.0%	0.0%	0.0%	0.0%	0.0%	0.0%	0.0%	0.6%
Buses	2	5	0	7	0	0	0	0	0	0	0	0	0	4	0	0	4	0	0	0	0	0	11
% Buses	20.0%	3.7%	0.0%	0.0%	0.0%	0.0%	0.0%	0.0%	0.0%	0.0%	0.0%	0.0%	0.0%	14.8%	0.0%	0.0%	0.0%	0.0%	0.0%	0.0%	0.0%	0.0%	6.4%
Pedestrians	0	0	0	0	0	0	0	0	0	0	0	0	1	0	0	0	0	0	0	1	0	0	0
% Pedestrians	0.0%	0.0%	0.0%	0.0%	0.0%	0.0%	0.0%	0.0%	0.0%	0.0%	0.0%	0.0%	100.0%	0.0%	0.0%	0.0%	0.0%	0.0%	0.0%	100.0%	0.0%	0.0%	0.0%
Bicycles on Crosswalk	0	0	0	0	0	0	0	0	0	0	0	0	0	0	0	0	0	0	0	0	0	0	0
% Bicycles on Crosswalk	0.0%	0.0%	0.0%	0.0%	0.0%	0.0%	0.0%	0.0%	0.0%	0.0%	0.0%	0.0%	0.0%	0.0%	0.0%	0.0%	0.0%	0.0%	0.0%	0.0%	0.0%	0.0%	0.0%

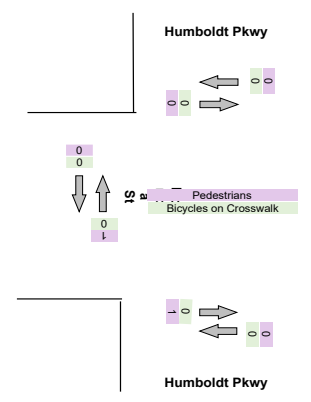
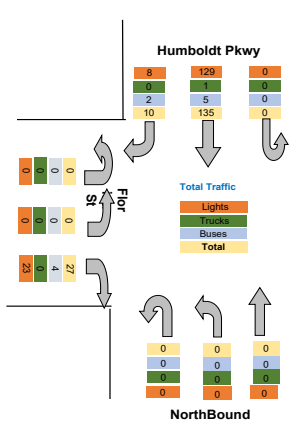

Turning Movement Peak Hour Data (PM)

4:30:00 PM

Leg Direction	Humboldt Pkwy Southbound						Humboldt Pkwy NorthBound						Florida St Eastbound						Total
	Right	Thru	U-Turn	App Total	Peds CW	Peds CCW	Thru	Left	U-Turn	App Total	Peds CW	Peds CCW	Right	Left	U-Turn	App Total	Peds CW	Peds CCW	
4:30:00 PM	3	48	0	51	0	0	0	0	0	0	0	0	14	0	0	14	0	1	65
4:45:00 PM	3	49	0	52	0	0	0	0	0	0	0	0	11	0	0	11	1	1	63
5:00:00 PM	4	49	0	53	0	0	0	0	0	0	0	0	7	0	0	7	0	0	60
5:15:00 PM	0	48	0	48	0	0	0	0	0	0	0	0	11	0	0	11	0	0	59
<b>Grand Total</b>	10	194	0	204	0	0	0	0	0	0	0	0	43	0	0	43	1	2	247
% Approach	4.9%	95.1%	0.0%	0.0%	0.0%	0.0%	14.2%	0.0%	0.0%	0.0%	0.0%	0.0%	45.1%	41.7%	0.0%	0.0%	0.0%	0.0%	0.0%
% Total	4.0%	78.5%	0.0%	82.6%	0.0%	0.0%	0.0%	0.0%	0.0%	0.0%	0.0%	0.0%	17.4%	0.0%	0.0%	17.4%	0.0%	0.0%	0.0%
PHF	0.625	0.990	0.000	0.962	0.000	0.000	0.000	0.000	0.000	0.000	0.000	0.000	0.768	0.000	0.000	0.768	0.000	0.000	0.950
Lights	8	189	0	197	0	0	0	0	0	0	0	0	38	0	0	38	0	0	235
% Lights	80.0%	97.4%	0.0%	96.6%	0.0%	0.0%	0.0%	0.0%	0.0%	0.0%	0.0%	0.0%	88.4%	0.0%	0.0%	88.4%	0.0%	0.0%	95.1%
Trucks	0	0	0	0	0	0	0	0	0	0	0	0	0	0	0	0	0	0	0
% Trucks	0.0%	0.0%	0.0%	0.0%	0.0%	0.0%	0.0%	0.0%	0.0%	0.0%	0.0%	0.0%	0.0%	0.0%	0.0%	0.0%	0.0%	0.0%	0.0%
Buses	2	4	0	6	0	0	0	0	0	0	0	0	4	0	0	4	0	0	10
% Buses	20.0%	2.1%	0.0%	0.0%	0.0%	0.0%	0.0%	0.0%	0.0%	0.0%	0.0%	0.0%	9.3%	0.0%	0.0%	0.0%	0.0%	0.0%	4.0%
Pedestrians	0	0	0	0	0	0	0	0	0	0	0	0	0	0	0	0	1	2	0
% Pedestrians	0.0%	0.0%	0.0%	0.0%	0.0%	0.0%	0.0%	0.0%	0.0%	0.0%	0.0%	0.0%	0.0%	0.0%	0.0%	0.0%	100.0%	100.0%	0.0%
Bicycles on Crosswalk	0	0	0	0	0	0	0	0	0	0	0	0	0	0	0	0	0	0	0
% Bicycles on Crosswalk	0.0%	0.0%	0.0%	0.0%	0.0%	0.0%	0.0%	0.0%	0.0%	0.0%	0.0%	0.0%	0.0%	0.0%	0.0%	0.0%	0.0%	0.0%	0.0%

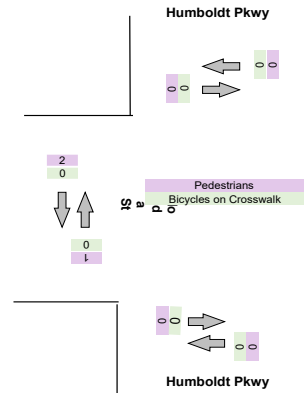
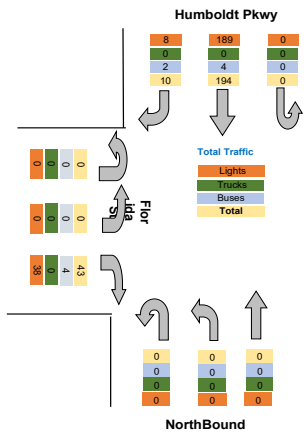



Turning Movement Data Plot

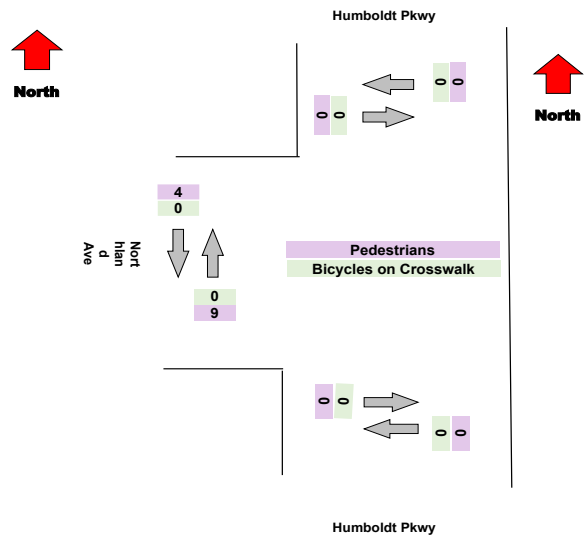
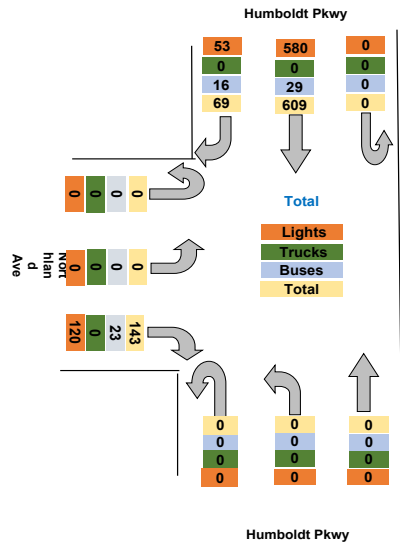

Turning Movement Peak Hour Data (AM)

7:30:00 AM

Leg Direction	Humboldt Pkwy Southbound						Humboldt Pkwy NorthBound						Northland Ave Eastbound					
	Right	Thru	U-Turn	App Total	Peds CW	Peds CCW	Thru	Left	U-Turn	App Total	Peds CW	Peds CCW	Right	Left	U-Turn	App Total	Peds CW	Peds CCW
7:30:00 AM	5	33	0	38	0	0	0	0	0	0	0	0	10	0	0	10	1	0
7:45:00 AM	6	27	0	33	0	0	0	0	0	0	0	0	7	0	0	7	1	0
8:00:00 AM	5	32	0	37	0	0	0	0	0	0	0	0	2	0	0	2	0	0
8:15:00 AM	5	37	0	42	0	0	0	0	0	0	0	0	5	0	0	5	0	0
<b>Grand Total</b>	21	129	0	150	0	0	0	0	0	0	0	0	24	0	0	24	2	0
% Approach	14.0%	86.0%	0.0%	0.0%	0.0%	0.0%	14.2%	0.0%	0.0%	0.0%	0.0%	0.0%	45.1%	41.7%	0.0%	0.0%	0.0%	0.0%
% Total	12.1%	74.1%	0.0%	86.2%	0.0%	0.0%	0.0%	0.0%	0.0%	0.0%	0.0%	0.0%	13.8%	0.0%	0.0%	13.8%	0.0%	0.0%
PHF	0.875	0.872	0.000	0.893	0.000	0.000	0.000	0.000	0.000	0.000	0.000	0.000	0.600	0.000	0.000	0.600	0.000	0.000
Lights	18	122	0	140	0	0	0	0	0	0	0	0	21	0	0	21	0	0
% Lights	85.7%	94.6%	0.0%	93.3%	0.0%	0.0%	0.0%	0.0%	0.0%	0.0%	0.0%	0.0%	87.5%	0.0%	0.0%	87.5%	0.0%	0.0%
Trucks	0	0	0	0	0	0	0	0	0	0	0	0	0	0	0	0	0	0
% Trucks	0.0%	0.0%	0.0%	0.0%	0.0%	0.0%	0.0%	0.0%	0.0%	0.0%	0.0%	0.0%	0.0%	0.0%	0.0%	0.0%	0.0%	0.0%
Buses	3	7	0	10	0	0	0	0	0	0	0	0	3	0	0	3	0	0
% Buses	14.3%	5.4%	0.0%	0.0%	0.0%	0.0%	0.0%	0.0%	0.0%	0.0%	0.0%	0.0%	12.5%	0.0%	0.0%	0.0%	0.0%	0.0%
Pedestrians	0	0	0	0	0	0	0	0	0	0	0	0	0	0	0	0	2	0
% Pedestrians	0.0%	0.0%	0.0%	0.0%	0.0%	0.0%	0.0%	0.0%	0.0%	0.0%	0.0%	0.0%	0.0%	0.0%	0.0%	0.0%	100.0%	0.0%
Bicycles on Crosswalk	0	0	0	0	0	0	0	0	0	0	0	0	0	0	0	0	0	0
% Bicycles on Crosswalk	0.0%	0.0%	0.0%	0.0%	0.0%	0.0%	0.0%	0.0%	0.0%	0.0%	0.0%	0.0%	0.0%	0.0%	0.0%	0.0%	0.0%	0.0%

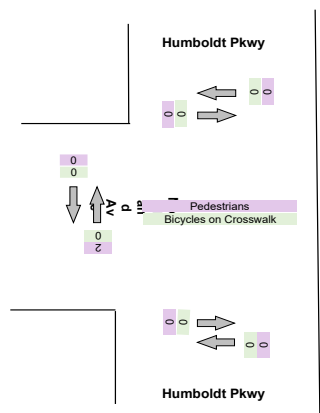
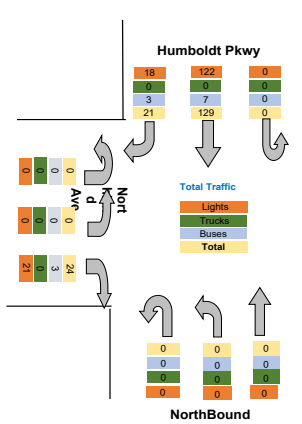

Turning Movement Peak Hour Data (PM)

4:30:00 PM

Leg Direction	Humboldt Pkwy Southbound						Humboldt Pkwy NorthBound						Northland Ave Eastbound					
	Right	Thru	U-Turn	App Total	Peds CW	Peds CCW	Thru	Left	U-Turn	App Total	Peds CW	Peds CCW	Right	Left	U-Turn	App Total	Peds CW	Peds CCW
4:30:00 PM	5	57	0	62	0	0	0	0	0	0	0	0	8	0	0	8	0	0
4:45:00 PM	9	49	0	58	0	0	0	0	0	0	0	0	4	0	0	4	0	1
5:00:00 PM	3	53	0	56	0	0	0	0	0	0	0	0	9	0	0	9	0	0
5:15:00 PM	2	43	0	45	0	0	0	0	0	0	0	0	7	0	0	7	0	0
<b>Grand Total</b>	<b>19</b>	<b>202</b>	<b>0</b>	<b>221</b>	<b>0</b>	<b>0</b>	<b>0</b>	<b>0</b>	<b>0</b>	<b>0</b>	<b>0</b>	<b>0</b>	<b>28</b>	<b>0</b>	<b>0</b>	<b>28</b>	<b>0</b>	<b>1</b>
% Approach	8.6%	91.4%	0.0%	0.0%	0.0%	0.0%	14.2%	0.0%	0.0%	0.0%	0.0%	0.0%	45.1%	41.7%	0.0%	0.0%	0.0%	0.0%
% Total	7.6%	81.1%	0.0%	88.8%	0.0%	0.0%	0.0%	0.0%	0.0%	0.0%	0.0%	0.0%	11.2%	0.0%	0.0%	11.2%	0.0%	0.0%
PHF	0.528	0.886	0.000	0.891	0.000	0.000	0.000	0.000	0.000	0.000	0.000	0.000	0.778	0.000	0.000	0.778	0.000	0.000
Lights	16	197	0	213	0	0	0	0	0	0	0	0	22	0	0	22	0	0
% Lights	84.2%	97.5%	0.0%	96.4%	0.0%	0.0%	0.0%	0.0%	0.0%	0.0%	0.0%	0.0%	78.6%	0.0%	0.0%	78.6%	0.0%	0.0%
Trucks	0	0	0	0	0	0	0	0	0	0	0	0	0	0	0	0	0	0
% Trucks	0.0%	0.0%	0.0%	0.0%	0.0%	0.0%	0.0%	0.0%	0.0%	0.0%	0.0%	0.0%	0.0%	0.0%	0.0%	0.0%	0.0%	0.0%
Buses	3	5	0	8	0	0	0	0	0	0	0	0	6	0	0	6	0	0
% Buses	15.8%	2.5%	0.0%	0.0%	0.0%	0.0%	0.0%	0.0%	0.0%	0.0%	0.0%	0.0%	21.4%	0.0%	0.0%	0.0%	0.0%	0.0%
Pedestrians	0	0	0	0	0	0	0	0	0	0	0	0	0	0	0	0	0	1
% Pedestrians	0.0%	0.0%	0.0%	0.0%	0.0%	0.0%	0.0%	0.0%	0.0%	0.0%	0.0%	0.0%	0.0%	0.0%	0.0%	0.0%	0.0%	100.0%
Bicycles on Crosswalk	0	0	0	0	0	0	0	0	0	0	0	0	0	0	0	0	0	0
% Bicycles on Crosswalk	0.0%	0.0%	0.0%	0.0%	0.0%	0.0%	0.0%	0.0%	0.0%	0.0%	0.0%	0.0%	0.0%	0.0%	0.0%	0.0%	0.0%	0.0%

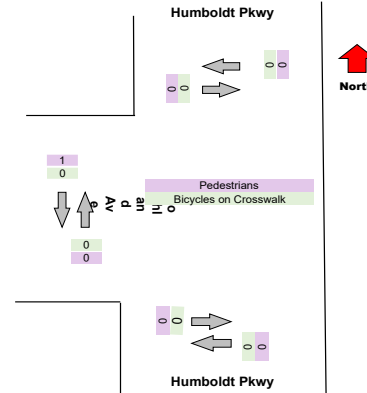
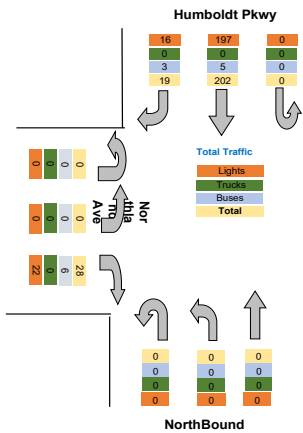

Intersection: Elm St Pine St  
 Location: Kennett Square, PA  
 Site: 01  
 Survey Date: Wednesday, 04-28-2021  
 GPS: 42.948550, -72.790034



<b>Total</b>
18
29
47
23
43
48
40
154
39
47
86
107
80
70
62
319
65
52
47
51
215
821
0.0%
0.0%
753
91.7%
0
0.0%
68
8.3%
0
0.0%
0.0%



Intersection: Elm St Pine St  
Location: Kennett Square, PA  
Site: 01  
Survey Date: Wednesday, 04-28-2021  
GPS: 42.948550, -72.790034



Total
48
40
39
47
174
0.906
161
92.5%
0
0.0%
13
7.5%
0
0.0%
0
0.0%

Intersection: Elm St Pine St  
Location: Kennett Square, PA  
Site: 01  
Survey Date: Wednesday, 04-28-2021  
GPS: 42.948550, -72.790034



Total
70
62
65
52
249
0.889
235
94.4%
0
0.0%
14
5.6%
0
0.0%
0
0.0%



Turning Movement Data Plot

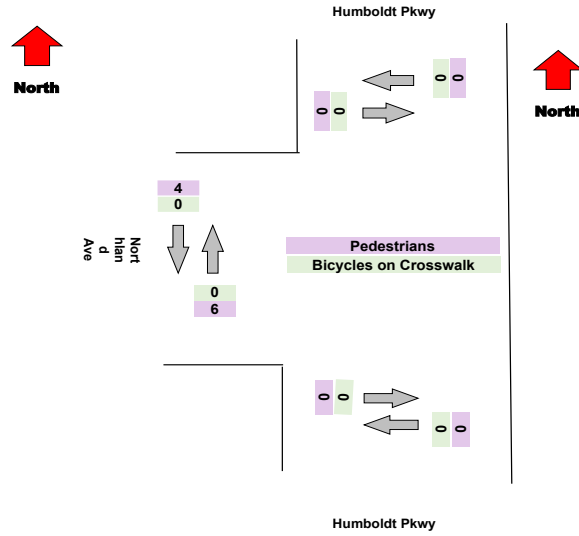
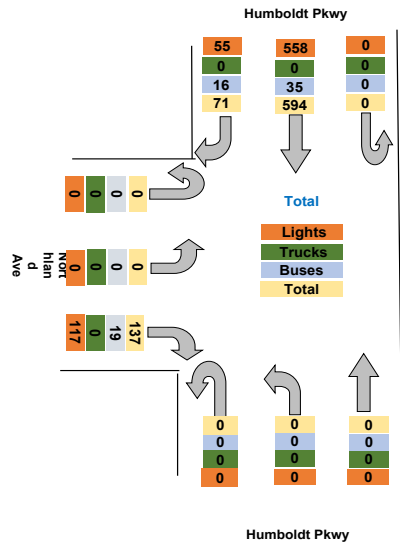

Turning Movement Peak Hour Data (AM)

7:30:00 AM

Leg Direction	Humboldt Pkwy Southbound						Humboldt Pkwy NorthBound						Northland Ave Eastbound					
	Right	Thru	U-Turn	App Total	Peds CW	Peds CCW	Thru	Left	U-Turn	App Total	Peds CW	Peds CCW	Right	Left	U-Turn	App Total	Peds CW	Peds CCW
7:30:00 AM	3	34	0	37	0	0	0	0	0	0	0	0	6	0	0	6	0	0
7:45:00 AM	3	35	0	38	0	0	0	0	0	0	0	0	5	0	0	5	0	0
8:00:00 AM	4	26	0	30	0	0	0	0	0	0	0	0	3	0	0	3	1	0
8:15:00 AM	5	35	0	40	0	0	0	0	0	0	0	0	7	0	0	7	0	0
<b>Grand Total</b>	15	130	0	145	0	0	0	0	0	0	0	0	21	0	0	21	1	0
% Approach	10.3%	89.7%	0.0%	0.0%	0.0%	0.0%	14.2%	0.0%	0.0%	0.0%	0.0%	0.0%	45.1%	41.7%	0.0%	0.0%	0.0%	0.0%
% Total	9.0%	78.3%	0.0%	87.3%	0.0%	0.0%	0.0%	0.0%	0.0%	0.0%	0.0%	0.0%	12.7%	0.0%	0.0%	12.7%	0.0%	0.0%
PHF	0.750	0.929	0.000	0.906	0.000	0.000	0.000	0.000	0.000	0.000	0.000	0.000	0.750	0.000	0.000	0.750	0.000	0.000
Lights	12	120	0	132	0	0	0	0	0	0	0	0	19	0	0	19	0	0
% Lights	80.0%	92.3%	0.0%	91.0%	0.0%	0.0%	0.0%	0.0%	0.0%	0.0%	0.0%	0.0%	90.5%	0.0%	0.0%	90.5%	0.0%	0.0%
Trucks	0	0	0	0	0	0	0	0	0	0	0	0	0	0	0	0	0	0
% Trucks	0.0%	0.0%	0.0%	0.0%	0.0%	0.0%	0.0%	0.0%	0.0%	0.0%	0.0%	0.0%	0.0%	0.0%	0.0%	0.0%	0.0%	0.0%
Buses	3	10	0	13	0	0	0	0	0	0	0	0	2	0	0	2	0	0
% Buses	20.0%	7.7%	0.0%	0.0%	0.0%	0.0%	0.0%	0.0%	0.0%	0.0%	0.0%	0.0%	9.5%	0.0%	0.0%	0.0%	0.0%	0.0%
Pedestrians	0	0	0	0	0	0	0	0	0	0	0	0	0	0	0	0	1	0
% Pedestrians	0.0%	0.0%	0.0%	0.0%	0.0%	0.0%	0.0%	0.0%	0.0%	0.0%	0.0%	0.0%	0.0%	0.0%	0.0%	0.0%	100.0%	0.0%
Bicycles on Crosswalk	0	0	0	0	0	0	0	0	0	0	0	0	0	0	0	0	0	0
% Bicycles on Crosswalk	0.0%	0.0%	0.0%	0.0%	0.0%	0.0%	0.0%	0.0%	0.0%	0.0%	0.0%	0.0%	0.0%	0.0%	0.0%	0.0%	0.0%	0.0%

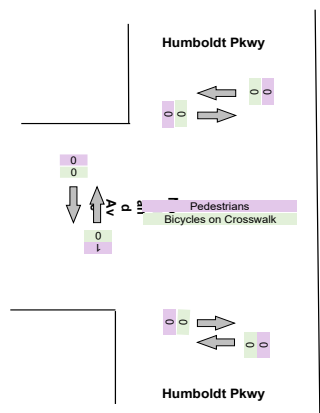
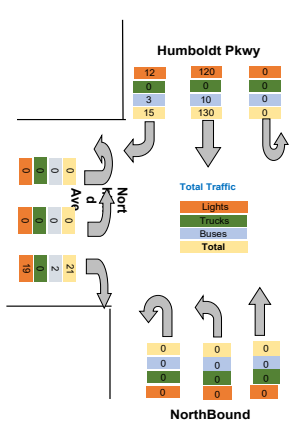

Turning Movement Peak Hour Data (PM)

4:30:00 PM

Leg Direction	Humboldt Pkwy Southbound						Humboldt Pkwy NorthBound						Northland Ave Eastbound					
	Right	Thru	U-Turn	App Total	Peds CW	Peds CCW	Thru	Left	U-Turn	App Total	Peds CW	Peds CCW	Right	Left	U-Turn	App Total	Peds CW	Peds CCW
4:30:00 PM	4	51	0	55	0	0	0	0	0	0	0	0	17	0	0	17	1	0
4:45:00 PM	3	51	0	54	0	0	0	0	0	0	0	0	11	0	0	11	1	0
5:00:00 PM	7	50	0	57	0	0	0	0	0	0	0	0	9	0	0	9	1	2
5:15:00 PM	9	41	0	50	0	0	0	0	0	0	0	0	7	0	0	7	0	0
<b>Grand Total</b>	23	193	0	216	0	0	0	0	0	0	0	0	44	0	0	44	3	2
% Approach	10.6%	89.4%	0.0%	0.0%	0.0%	0.0%	14.2%	0.0%	0.0%	0.0%	0.0%	0.0%	45.1%	41.7%	0.0%	0.0%	0.0%	0.0%
% Total	8.8%	74.2%	0.0%	83.1%	0.0%	0.0%	0.0%	0.0%	0.0%	0.0%	0.0%	0.0%	16.9%	0.0%	0.0%	16.9%	0.0%	0.0%
PHF	0.639	0.946	0.000	0.947	0.000	0.000	0.000	0.000	0.000	0.000	0.000	0.000	0.647	0.000	0.000	0.647	0.000	0.000
Lights	20	186	0	206	0	0	0	0	0	0	0	0	37	0	0	37	0	0
% Lights	87.0%	96.4%	0.0%	95.4%	0.0%	0.0%	0.0%	0.0%	0.0%	0.0%	0.0%	0.0%	84.1%	0.0%	0.0%	84.1%	0.0%	0.0%
Trucks	0	0	0	0	0	0	0	0	0	0	0	0	0	0	0	0	0	0
% Trucks	0.0%	0.0%	0.0%	0.0%	0.0%	0.0%	0.0%	0.0%	0.0%	0.0%	0.0%	0.0%	0.0%	0.0%	0.0%	0.0%	0.0%	0.0%
Buses	3	6	0	9	0	0	0	0	0	0	0	0	6	0	0	6	0	0
% Buses	13.0%	3.1%	0.0%	0.0%	0.0%	0.0%	0.0%	0.0%	0.0%	0.0%	0.0%	0.0%	13.6%	0.0%	0.0%	0.0%	0.0%	0.0%
Pedestrians	0	0	0	0	0	0	0	0	0	0	0	0	0	0	0	0	3	2
% Pedestrians	0.0%	0.0%	0.0%	0.0%	0.0%	0.0%	0.0%	0.0%	0.0%	0.0%	0.0%	0.0%	0.0%	0.0%	0.0%	0.0%	100.0%	100.0%
Bicycles on Crosswalk	0	0	0	0	0	0	0	0	0	0	0	0	0	0	0	0	0	0
% Bicycles on Crosswalk	0.0%	0.0%	0.0%	0.0%	0.0%	0.0%	0.0%	0.0%	0.0%	0.0%	0.0%	0.0%	0.0%	0.0%	0.0%	0.0%	0.0%	0.0%

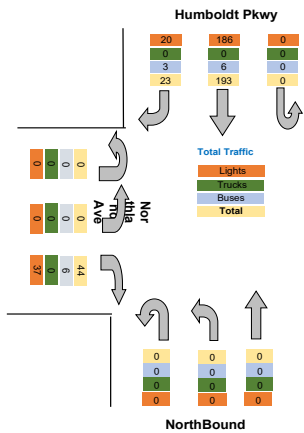

North

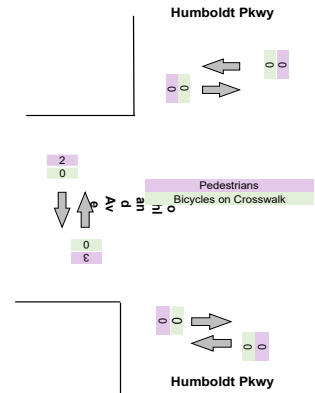

North

Intersection: Elm St Pine St  
 Location: Kennett Square, PA  
 Site: 01  
 Survey Date: Wednesday, 04-28-2021  
 GPS: 42.948550, -72.790034



<b>Total</b>
27
19
46
19
36
43
43
141
33
47
80
80
86
72
65
303
66
57
51
58
232
802
0.0%
0.0%
730
91.0%
0
0.0%
70
8.7%
0
0.0%
0.0%

Intersection: Elm St Pine St  
Location: Kennett Square, PA  
Site: 01  
Survey Date: Wednesday, 04-28-2021  
GPS: 42.948550, -72.790034

Total
43
43
33
47
166
0.883
151
91.0%
0
0.0%
15
9.0%
0
0.0%
0
0.0%



Intersection: Elm St Pine St  
Location: Kennett Square, PA  
Site: 01  
Survey Date: Wednesday, 04-28-2021  
GPS: 42.948550, -72.790034



Total
72
65
66
57
260
0.903
243
93.5%
0
0.0%
15
5.8%
0
0.0%
0
0.0%

Project	Labella
Project Code	Labella
Site Name	K
Legs and Movements	All Processed Legs & Movement
Bin Size	15 minutes
Survey Date	2021-10-28, Thursday
Location	K
Latitude and Longitude	42.919163, -78.843742

	Start	End	PHF
Forced Peak AM	2021/10/28 07:30:00	2021/10/28 08:30:00	0.939
Forced Peak PM	2021/10/28 16:30:00	2021/10/28 17:30:00	0.928
AM Peak	2021/10/28 07:30:00	2021/10/28 08:30:00	0.939
PM Peak	2021/10/28 16:30:00	2021/10/28 17:30:00	0.928

Turning Movement Data

Leg Direction	Humboldt Pkwy Southbound						Humboldt Pkwy Northbound						Northland Ave Eastbound						Total
	Right	Thru	U-Turn	App Total	Peds CW	Peds CCW	Thru	Left	U-Turn	App Total	Peds CW	Peds CCW	Right	Left	U-Turn	App Total	Peds CW	Peds CCW	
Start Time																			
6:30:00 AM	0	16	0	16	0	0	0	0	0	0	0	0	5	0	0	5	0	0	21
6:45:00 AM	1	17	0	18	0	0	0	0	0	0	0	0	3	0	0	3	0	0	42
Hourly Total	1	33	0	34	0	0	0	0	0	0	0	0	8	0	0	8	0	0	21
7:00:00 AM	3	21	0	24	0	0	0	0	0	0	0	0	2	0	0	2	0	0	26
7:15:00 AM	3	18	0	21	0	0	0	0	0	0	1	8	0	0	9	0	0	30	
7:30:00 AM	6	31	0	37	0	0	0	0	0	0	0	8	0	0	8	1	0	45	
7:45:00 AM	3	39	0	42	0	0	0	0	0	0	0	7	0	0	7	0	0	49	
Hourly Total	15	109	0	124	0	0	0	0	0	0	1	25	0	0	26	1	0	150	
8:00:00 AM	2	38	0	40	0	0	0	0	0	0	0	3	0	0	3	0	0	43	
8:15:00 AM	7	35	0	42	0	0	0	0	0	0	0	5	0	0	5	0	0	47	
Hourly Total	9	73	0	82	0	0	0	0	0	0	0	8	0	0	8	0	0	90	
4:00:00 PM	3	45	0	48	0	0	0	0	0	0	0	26	0	0	26	0	1	74	
4:15:00 PM	3	49	0	52	0	0	0	0	0	0	0	21	0	0	21	1	0	73	
4:30:00 PM	7	51	0	58	0	0	0	0	0	0	0	16	0	0	16	0	1	74	
4:45:00 PM	5	58	0	63	0	0	0	0	0	0	0	13	0	0	13	1	0	76	
Hourly Total	18	203	0	221	0	0	0	0	0	0	0	76	0	0	76	2	2	297	
5:00:00 PM	8	46	0	54	0	0	0	0	0	0	0	6	0	0	6	0	0	60	
5:15:00 PM	9	49	0	58	0	0	0	0	0	0	0	14	0	0	14	0	0	72	
5:30:00 PM	3	43	0	46	0	0	0	0	0	0	0	10	0	0	10	1	0	56	
5:45:00 PM	5	45	0	50	0	0	0	0	0	0	0	8	0	0	8	0	0	58	
Hourly Total	25	183	0	208	0	0	0	0	0	0	0	38	0	0	38	1	0	246	
Grand Total	68	601	0	669	0	0	0	0	0	0	1	155	0	0	156	4	2	825	
% Approach	10.2%	89.8%	0.0%	0.0%	0.0%	0.0%	0.0%	0.0%	0.0%	0.0%	0.0%	99.4%	0.0%	0.0%	0.0%	0.0%	0.0%	0.0%	0.0%
% Total	8.2%	72.8%	0.0%	81.1%	0.0%	0.0%	0.0%	0.0%	0.0%	0.0%	0.0%	18.8%	0.0%	0.0%	18.9%	0.0%	0.0%	0.0%	0.0%
Lights	57	566	0	623	0	0	0	0	0	0	0	131	0	0	131	0	0	754	
% Lights	83.8%	94.2%	0.0%	93.1%	0.0%	0.0%	0.0%	0.0%	0.0%	0.0%	0.0%	84.5%	0.0%	0.0%	84.0%	0.0%	0.0%	0.0%	91.4%
Trucks	0	1	0	1	0	0	0	0	0	0	0	1	0	0	1	0	0	2	
% Trucks	0.0%	0.2%	0.0%	0.1%	0.0%	0.0%	0.0%	0.0%	0.0%	0.0%	0.0%	0.6%	0.0%	0.0%	0.6%	0.0%	0.0%	0.0%	0.2%
Buses	11	32	0	43	0	0	0	0	0	0	0	23	0	0	23	0	0	66	
% Buses	16.2%	5.3%	0.0%	0.0%	0.0%	0.0%	0.0%	0.0%	0.0%	0.0%	0.0%	14.8%	0.0%	0.0%	0.0%	0.0%	0.0%	0.0%	8.0%
Pedestrians	0	0	0	0	0	0	0	0	0	0	1	0	0	0	0	3	2	0	
% Pedestrians	0.0%	0.0%	0.0%	0.0%	0.0%	0.0%	0.0%	0.0%	0.0%	0.0%	100.0%	0.0%	0.0%	0.0%	0.0%	75.0%	100.0%	0.0%	0.0%
% Bicycles on Crosswalk	0.0%	0.0%	0.0%	0.0%	0.0%	0.0%	0.0%	0.0%	0.0%	0.0%	0.0%	0.0%	0.0%	0.0%	0.0%	25.0%	0.0%	0.0%	0.0%

Turning Movement Data Plot

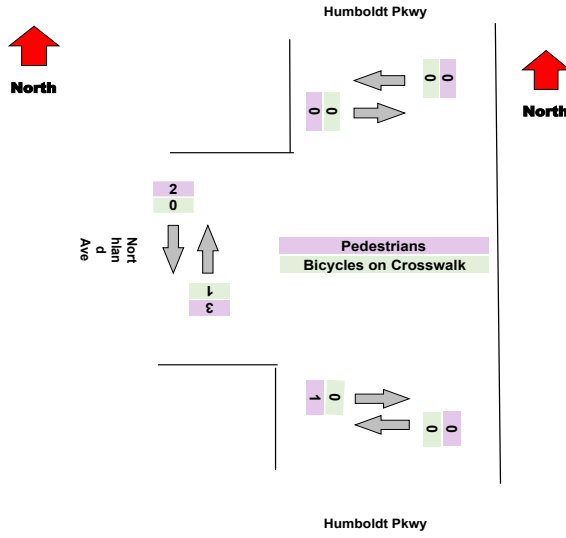
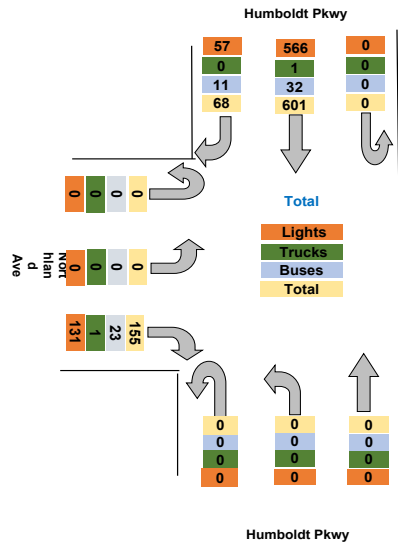

Turning Movement Peak Hour Data (AM)

7:30:00 AM

Leg Direction	Humboldt Pkwy Southbound						Humboldt Pkwy NorthBound						Northland Ave Eastbound						Total									
	Right	Thru	U-Turn	App	Total	Peds	CW	Peds	CCW	Thru	Left	U-Turn	App	Total	Peds	CW	Peds	CCW		Right	Left	U-Turn	App	Total	Peds	CW	Peds	CCW
7:30:00 AM	6	31	0	37	0	0	0	0	0	0	0	0	0	0	0	0	0	0	8	0	0	8	1	0	0	0	0	45
7:45:00 AM	3	39	0	42	0	0	0	0	0	0	0	0	0	0	0	0	0	0	7	0	0	7	0	0	0	0	49	
8:00:00 AM	2	38	0	40	0	0	0	0	0	0	0	0	0	0	0	0	0	0	3	0	0	3	0	0	0	0	43	
8:15:00 AM	7	35	0	42	0	0	0	0	0	0	0	0	0	0	0	0	0	0	5	0	0	5	0	0	0	0	47	
<b>Grand Total</b>	<b>18</b>	<b>143</b>	<b>0</b>	<b>161</b>	<b>0</b>	<b>0</b>	<b>0</b>	<b>0</b>	<b>0</b>	<b>0</b>	<b>0</b>	<b>0</b>	<b>0</b>	<b>0</b>	<b>0</b>	<b>0</b>	<b>0</b>	<b>23</b>	<b>0</b>	<b>0</b>	<b>23</b>	<b>1</b>	<b>0</b>	<b>0</b>	<b>0</b>	<b>0</b>	<b>184</b>	
% Approach	11.2%	88.8%	0.0%	0.0%	0.0%	0.0%	0.0%	0.0%	14.2%	0.0%	0.0%	0.0%	0.0%	0.0%	0.0%	0.0%	0.0%	45.1%	41.7%	0.0%	0.0%	0.0%	0.0%	0.0%	0.0%	0.0%	0.0%	
% Total	9.8%	77.7%	0.0%	87.5%	0.0%	0.0%	0.0%	0.0%	0.0%	0.0%	0.0%	0.0%	0.0%	0.0%	0.0%	0.0%	0.0%	12.5%	0.0%	0.0%	12.5%	0.0%	0.0%	0.0%	0.0%	0.0%	0.0%	
PHF	0.643	0.917	0.000	0.958	0.000	0.000	0.000	0.000	0.000	0.000	0.000	0.000	0.000	0.000	0.000	0.000	0.000	0.719	0.000	0.000	0.719	0.000	0.000	0.000	0.000	0.000	0.939	
Lights	16	135	0	151	0	0	0	0	0	0	0	0	0	0	0	0	0	0	21	0	0	21	0	0	0	0	172	
% Lights	88.9%	94.4%	0.0%	93.8%	0.0%	0.0%	0.0%	0.0%	0.0%	0.0%	0.0%	0.0%	0.0%	0.0%	0.0%	0.0%	0.0%	91.3%	0.0%	0.0%	91.3%	0.0%	0.0%	0.0%	0.0%	0.0%	93.5%	
Trucks	0	1	0	1	0	0	0	0	0	0	0	0	0	0	0	0	0	0	0	0	0	0	0	0	0	0	1	
% Trucks	0.0%	0.7%	0.0%	0.6%	0.0%	0.0%	0.0%	0.0%	0.0%	0.0%	0.0%	0.0%	0.0%	0.0%	0.0%	0.0%	0.0%	0.0%	0.0%	0.0%	0.0%	0.0%	0.0%	0.0%	0.0%	0.0%	0.5%	
Buses	2	7	0	9	0	0	0	0	0	0	0	0	0	0	0	0	0	0	2	0	0	2	0	0	0	0	11	
% Buses	11.1%	4.9%	0.0%	0.0%	0.0%	0.0%	0.0%	0.0%	0.0%	0.0%	0.0%	0.0%	0.0%	0.0%	0.0%	0.0%	0.0%	8.7%	0.0%	0.0%	0.0%	0.0%	0.0%	0.0%	0.0%	0.0%	6.0%	
Pedestrians	0	0	0	0	0	0	0	0	0	0	0	0	0	0	0	0	0	0	0	0	0	0	1	0	0	0	0	
% Pedestrians	0.0%	0.0%	0.0%	0.0%	0.0%	0.0%	0.0%	0.0%	0.0%	0.0%	0.0%	0.0%	0.0%	0.0%	0.0%	0.0%	0.0%	0.0%	0.0%	0.0%	0.0%	0.0%	100.0%	0.0%	0.0%	0.0%	0.0%	
Bicycles on Crosswalk	0	0	0	0	0	0	0	0	0	0	0	0	0	0	0	0	0	0	0	0	0	0	0	0	0	0	0	
% Bicycles on Crosswalk	0.0%	0.0%	0.0%	0.0%	0.0%	0.0%	0.0%	0.0%	0.0%	0.0%	0.0%	0.0%	0.0%	0.0%	0.0%	0.0%	0.0%	0.0%	0.0%	0.0%	0.0%	0.0%	0.0%	0.0%	0.0%	0.0%	0.0%	

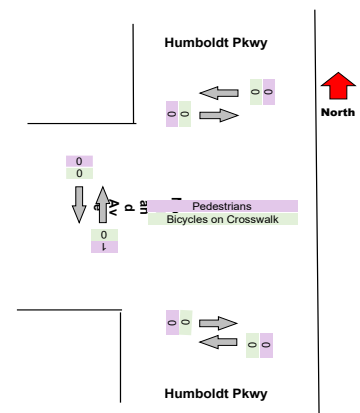
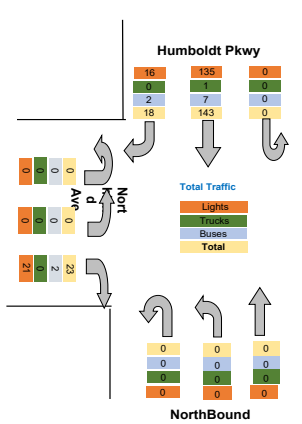

Turning Movement Peak Hour Data (PM)

4:30:00 PM

Leg Direction	Humboldt Pkwy Southbound						Humboldt Pkwy NorthBound						Northland Ave Eastbound						Total
	Right	Thru	U-Turn	App Total	Peds CW	Peds CCW	Thru	Left	U-Turn	App Total	Peds CW	Peds CCW	Right	Left	U-Turn	App Total	Peds CW	Peds CCW	
4:30:00 PM	7	51	0	58	0	0	0	0	0	0	0	0	16	0	0	16	0	1	74
4:45:00 PM	5	58	0	63	0	0	0	0	0	0	0	0	13	0	0	13	1	0	76
5:00:00 PM	8	46	0	54	0	0	0	0	0	0	0	0	6	0	0	6	0	0	60
5:15:00 PM	9	49	0	58	0	0	0	0	0	0	0	0	14	0	0	14	0	0	72
<b>Grand Total</b>	29	204	0	233	0	0	0	0	0	0	0	0	49	0	0	49	1	1	282
% Approach	12.4%	87.6%	0.0%	0.0%	0.0%	0.0%	14.2%	0.0%	0.0%	0.0%	0.0%	0.0%	45.1%	41.7%	0.0%	0.0%	0.0%	0.0%	0.0%
% Total	10.3%	72.3%	0.0%	82.6%	0.0%	0.0%	0.0%	0.0%	0.0%	0.0%	0.0%	0.0%	17.4%	0.0%	0.0%	17.4%	0.0%	0.0%	0.0%
PHF	0.806	0.879	0.000	0.925	0.000	0.000	0.000	0.000	0.000	0.000	0.000	0.000	0.766	0.000	0.000	0.766	0.000	0.000	0.928
Lights	27	196	0	223	0	0	0	0	0	0	0	0	40	0	0	40	0	0	263
% Lights	93.1%	96.1%	0.0%	95.7%	0.0%	0.0%	0.0%	0.0%	0.0%	0.0%	0.0%	0.0%	81.6%	0.0%	0.0%	81.6%	0.0%	0.0%	93.3%
Trucks	0	0	0	0	0	0	0	0	0	0	0	0	1	0	0	1	0	0	1
% Trucks	0.0%	0.0%	0.0%	0.0%	0.0%	0.0%	0.0%	0.0%	0.0%	0.0%	0.0%	0.0%	2.0%	0.0%	0.0%	2.0%	0.0%	0.0%	0.4%
Buses	2	6	0	8	0	0	0	0	0	0	0	0	8	0	0	8	0	0	16
% Buses	6.9%	2.9%	0.0%	0.0%	0.0%	0.0%	0.0%	0.0%	0.0%	0.0%	0.0%	0.0%	16.3%	0.0%	0.0%	0.0%	0.0%	0.0%	5.7%
Pedestrians	0	0	0	0	0	0	0	0	0	0	0	0	0	0	0	0	1	1	0
% Pedestrians	0.0%	0.0%	0.0%	0.0%	0.0%	0.0%	0.0%	0.0%	0.0%	0.0%	0.0%	0.0%	0.0%	0.0%	0.0%	0.0%	100.0%	100.0%	0.0%
Bicycles on Crosswalk	0	0	0	0	0	0	0	0	0	0	0	0	0	0	0	0	0	0	0
% Bicycles on Crosswalk	0.0%	0.0%	0.0%	0.0%	0.0%	0.0%	0.0%	0.0%	0.0%	0.0%	0.0%	0.0%	0.0%	0.0%	0.0%	0.0%	0.0%	0.0%	0.0%

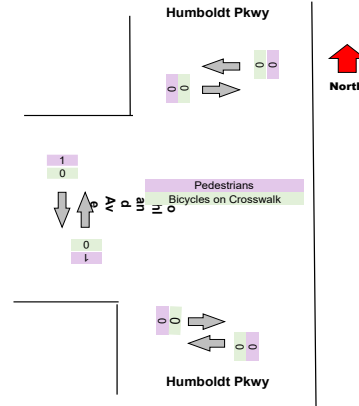
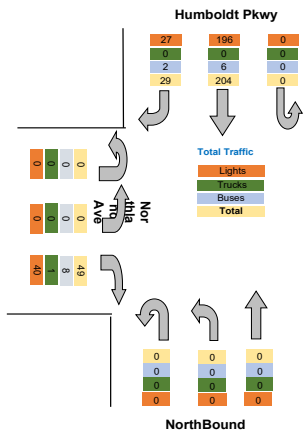



Turning Movement Data Plot

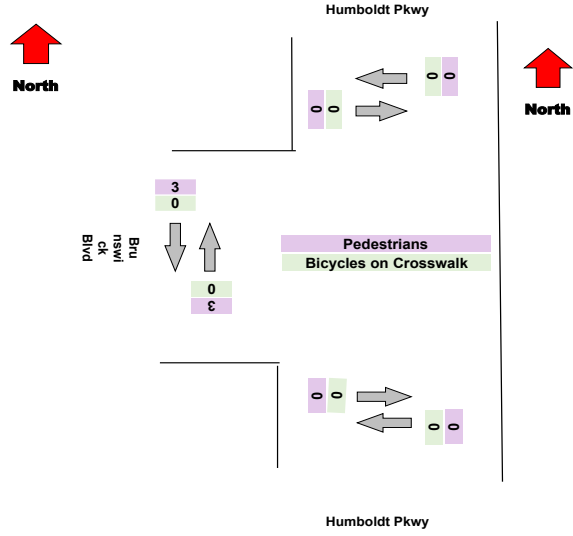
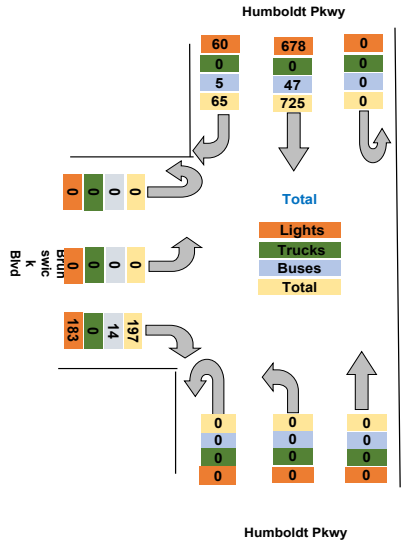

Turning Movement Peak Hour Data (AM)

7:30:00 AM

Leg Direction	Humboldt Pkwy Southbound						Humboldt Pkwy NorthBound						Brunswick Blvd Eastbound						Total			
	Right	Thru	U-Turn	App	Total	Peds CW	Peds CCW	Thru	Left	U-Turn	App	Total	Peds CW	Peds CCW	Right	Left	U-Turn	App		Total	Peds CW	Peds CCW
7:30:00 AM	3	48	0	51	0	0	0	0	0	0	0	0	0	0	13	0	0	13	0	0	0	64
7:45:00 AM	1	42	0	43	0	0	0	0	0	0	0	0	0	0	13	0	0	13	1	0	0	56
8:00:00 AM	6	30	0	36	0	0	0	0	0	0	0	0	0	0	10	0	0	10	0	0	0	46
8:15:00 AM	4	41	0	45	0	0	0	0	0	0	0	0	0	0	19	0	0	19	0	0	0	64
<b>Grand Total</b>	<b>14</b>	<b>161</b>	<b>0</b>	<b>175</b>	<b>0</b>	<b>0</b>	<b>0</b>	<b>0</b>	<b>0</b>	<b>0</b>	<b>0</b>	<b>0</b>	<b>0</b>	<b>0</b>	<b>55</b>	<b>0</b>	<b>0</b>	<b>55</b>	<b>1</b>	<b>0</b>	<b>0</b>	<b>230</b>
% Approach	8.0%	92.0%	0.0%	0.0%	0.0%	0.0%	14.2%	0.0%	0.0%	0.0%	0.0%	0.0%	0.0%	0.0%	45.1%	41.7%	0.0%	0.0%	0.0%	0.0%	0.0%	0.0%
% Total	6.1%	70.0%	0.0%	76.1%	0.0%	0.0%	0.0%	0.0%	0.0%	0.0%	0.0%	0.0%	0.0%	0.0%	23.9%	0.0%	0.0%	23.9%	0.0%	0.0%	0.0%	0.0%
PHF	0.583	0.839	0.000	0.858	0.000	0.000	0.000	0.000	0.000	0.000	0.000	0.000	0.000	0.000	0.724	0.000	0.000	0.724	0.000	0.000	0.000	0.898
Lights	13	151	0	164	0	0	0	0	0	0	0	0	0	0	51	0	0	51	0	0	0	215
% Lights	92.9%	93.8%	0.0%	93.7%	0.0%	0.0%	0.0%	0.0%	0.0%	0.0%	0.0%	0.0%	0.0%	0.0%	92.7%	0.0%	0.0%	92.7%	0.0%	0.0%	0.0%	93.5%
Trucks	0	0	0	0	0	0	0	0	0	0	0	0	0	0	0	0	0	0	0	0	0	0
% Trucks	0.0%	0.0%	0.0%	0.0%	0.0%	0.0%	0.0%	0.0%	0.0%	0.0%	0.0%	0.0%	0.0%	0.0%	0.0%	0.0%	0.0%	0.0%	0.0%	0.0%	0.0%	0.0%
Buses	1	10	0	11	0	0	0	0	0	0	0	0	0	0	4	0	0	4	0	0	0	15
% Buses	7.1%	6.2%	0.0%	6.3%	0.0%	0.0%	0.0%	0.0%	0.0%	0.0%	0.0%	0.0%	0.0%	0.0%	7.3%	0.0%	0.0%	7.3%	0.0%	0.0%	0.0%	6.5%
Pedestrians	0	0	0	0	0	0	0	0	0	0	0	0	0	0	0	0	0	0	0	1	0	0
% Pedestrians	0.0%	0.0%	0.0%	0.0%	0.0%	0.0%	0.0%	0.0%	0.0%	0.0%	0.0%	0.0%	0.0%	0.0%	0.0%	0.0%	0.0%	0.0%	0.0%	100.0%	0.0%	0.0%
Bicycles on Crosswalk	0	0	0	0	0	0	0	0	0	0	0	0	0	0	0	0	0	0	0	0	0	0
% Bicycles on Crosswalk	0.0%	0.0%	0.0%	0.0%	0.0%	0.0%	0.0%	0.0%	0.0%	0.0%	0.0%	0.0%	0.0%	0.0%	0.0%	0.0%	0.0%	0.0%	0.0%	0.0%	0.0%	0.0%

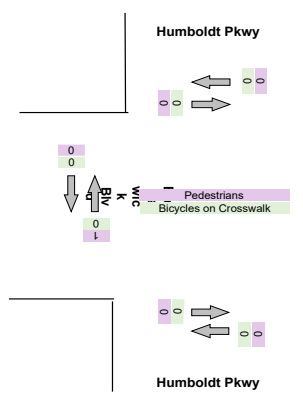
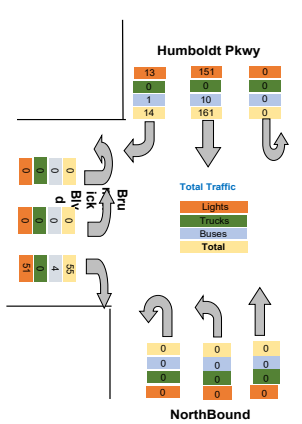



Turning Movement Peak Hour Data (PM)

4:30:00 PM

Leg Direction	Humboldt Pkwy Southbound						Humboldt Pkwy NorthBound						Brunswick Blvd Eastbound						Total
	Right	Thru	U-Turn	App Total	Peds CW	Peds CCW	Thru	Left	U-Turn	App Total	Peds CW	Peds CCW	Right	Left	U-Turn	App Total	Peds CW	Peds CCW	
4:30:00 PM	8	59	0	67	0	0	0	0	0	0	0	0	16	0	0	16	0	0	83
4:45:00 PM	9	53	0	62	0	0	0	0	0	0	0	0	16	0	0	16	0	1	78
5:00:00 PM	6	57	0	63	0	0	0	0	0	0	0	0	10	0	0	10	0	0	73
5:15:00 PM	7	44	0	51	0	0	0	0	0	0	0	0	15	0	0	15	0	0	66
<b>Grand Total</b>	<b>30</b>	<b>213</b>	<b>0</b>	<b>243</b>	<b>0</b>	<b>0</b>	<b>0</b>	<b>0</b>	<b>0</b>	<b>0</b>	<b>0</b>	<b>0</b>	<b>57</b>	<b>0</b>	<b>0</b>	<b>57</b>	<b>0</b>	<b>1</b>	<b>300</b>
% Approach	12.3%	87.7%	0.0%	0.0%	0.0%	0.0%	14.2%	0.0%	0.0%	0.0%	0.0%	0.0%	45.1%	41.7%	0.0%	0.0%	0.0%	0.0%	0.0%
% Total	10.0%	71.0%	0.0%	81.0%	0.0%	0.0%	0.0%	0.0%	0.0%	0.0%	0.0%	0.0%	19.0%	0.0%	0.0%	19.0%	0.0%	0.0%	0.0%
PHF	0.833	0.903	0.000	0.907	0.000	0.000	0.000	0.000	0.000	0.000	0.000	0.000	0.891	0.000	0.000	0.891	0.000	0.000	0.904
Lights	28	200	0	228	0	0	0	0	0	0	0	0	52	0	0	52	0	0	280
% Lights	93.3%	93.9%	0.0%	93.8%	0.0%	0.0%	0.0%	0.0%	0.0%	0.0%	0.0%	0.0%	91.2%	0.0%	0.0%	91.2%	0.0%	0.0%	93.3%
Trucks	0	0	0	0	0	0	0	0	0	0	0	0	0	0	0	0	0	0	0
% Trucks	0.0%	0.0%	0.0%	0.0%	0.0%	0.0%	0.0%	0.0%	0.0%	0.0%	0.0%	0.0%	0.0%	0.0%	0.0%	0.0%	0.0%	0.0%	0.0%
Buses	2	13	0	15	0	0	0	0	0	0	0	0	5	0	0	5	0	0	20
% Buses	6.7%	6.1%	0.0%	6.2%	0.0%	0.0%	0.0%	0.0%	0.0%	0.0%	0.0%	0.0%	8.8%	0.0%	0.0%	8.8%	0.0%	0.0%	6.7%
Pedestrians	0	0	0	0	0	0	0	0	0	0	0	0	0	0	0	0	0	1	0
% Pedestrians	0.0%	0.0%	0.0%	0.0%	0.0%	0.0%	0.0%	0.0%	0.0%	0.0%	0.0%	0.0%	0.0%	0.0%	0.0%	0.0%	0.0%	100.0%	0.0%
Bicycles on Crosswalk	0	0	0	0	0	0	0	0	0	0	0	0	0	0	0	0	0	0	0
% Bicycles on Crosswalk	0.0%	0.0%	0.0%	0.0%	0.0%	0.0%	0.0%	0.0%	0.0%	0.0%	0.0%	0.0%	0.0%	0.0%	0.0%	0.0%	0.0%	0.0%	0.0%

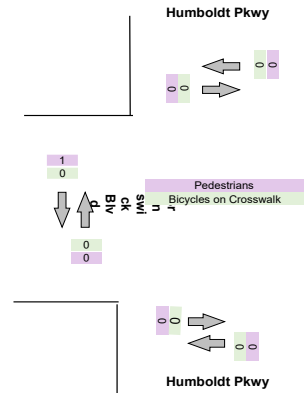
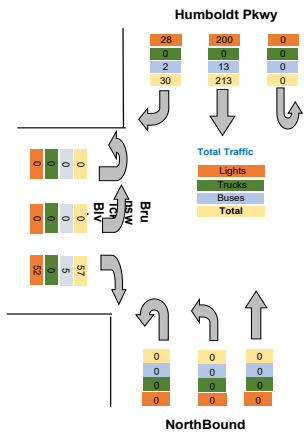

Project	Labella
Project Code	Labella
Site Name	L
Legs and Movements	All Processed Legs & Movement
Bin Size	15 minutes
Survey Date	2021-10-27, Wednesday
Location	L
Latitude and Longitude	42.916951, -78.843751

	Start	End	PHF
Forced Peak AM	2021/10/27 07:30:00	2021/10/27 08:30:00	0.904
Forced Peak PM	2021/10/27 16:30:00	2021/10/27 17:30:00	0.824
AM Peak	2021/10/27 07:30:00	2021/10/27 08:30:00	0.904
PM Peak	2021/10/27 16:30:00	2021/10/27 17:30:00	0.824

Turning Movement Data

Leg Direction	Humboldt Pkwy						Humboldt Pkwy						Brunswick Blvd					
	Southbound			Northbound			Northbound			Eastbound			Eastbound			Eastbound		
Start Time	Right	Thru	U-Turn	App Total	Peds CW	Peds CCW	Thru	Left	U-Turn	App Total	Peds CW	Peds CCW	Right	Left	U-Turn	App Total	Peds CW	Peds CCW
6:30:00 AM	1	27	0	28	0	0	0	0	0	0	0	0	6	0	0	6	0	1
6:45:00 AM	0	22	0	22	0	0	0	0	0	0	0	0	7	0	0	7	0	0
<b>Hourly Total</b>	1	49	0	50	0	0	0	0	0	0	0	0	13	0	0	13	0	1
7:00:00 AM	2	10	0	12	0	0	0	0	0	0	0	0	4	0	0	4	0	0
7:15:00 AM	3	34	0	37	0	0	0	0	0	0	0	0	13	0	0	13	0	0
7:30:00 AM	2	39	0	41	0	0	0	0	0	0	0	0	20	0	0	20	0	0
7:45:00 AM	3	42	0	45	0	0	0	0	0	0	0	0	20	0	0	20	0	0
<b>Hourly Total</b>	10	125	0	135	0	0	0	0	0	0	0	0	57	0	0	57	0	0
8:00:00 AM	2	35	0	37	0	0	0	0	0	0	0	0	14	0	0	14	0	0
8:15:00 AM	5	40	0	45	0	0	0	0	0	0	0	0	13	0	0	13	0	0
<b>Hourly Total</b>	7	75	0	82	0	0	0	0	0	0	0	0	27	0	0	27	0	0
4:00:00 PM	3	75	0	78	0	0	0	0	0	0	0	0	12	0	0	12	0	0
4:15:00 PM	5	67	0	72	0	0	0	0	0	0	0	0	10	0	0	10	2	0
4:30:00 PM	4	67	0	71	0	0	0	0	0	0	0	0	20	0	0	20	1	0
4:45:00 PM	3	51	0	54	0	0	0	0	0	0	0	0	17	0	0	17	0	0
<b>Hourly Total</b>	15	260	0	275	0	0	0	0	0	0	0	0	59	0	0	59	3	0
5:00:00 PM	7	50	0	57	0	0	0	0	0	0	0	0	14	0	0	14	1	1
5:15:00 PM	6	44	0	50	0	0	0	0	0	0	0	0	17	0	0	17	1	0
5:30:00 PM	4	46	0	50	0	0	0	0	0	0	0	0	13	0	0	13	0	0
5:45:00 PM	6	43	0	49	0	0	0	0	0	0	0	0	16	0	0	16	0	0
<b>Hourly Total</b>	23	183	0	206	0	0	0	0	0	0	0	0	60	0	0	60	2	1
<b>Grand Total</b>	56	692	0	748	0	0	0	0	0	0	0	0	216	0	0	216	5	2
<b>% Approach</b>	7.5%	92.5%	0.0%	0.0%	0.0%	0.0%	0.0%	0.0%	0.0%	0.0%	0.0%	0.0%	100.0%	0.0%	0.0%	0.0%	0.0%	0.0%
<b>% Total</b>	5.8%	71.8%	0.0%	77.6%	0.0%	0.0%	0.0%	0.0%	0.0%	0.0%	0.0%	0.0%	22.4%	0.0%	0.0%	22.4%	0.0%	0.0%
<b>Lights</b>	47	649	0	696	0	0	0	0	0	0	0	0	201	0	0	201	0	0
<b>% Lights</b>	83.9%	93.8%	0.0%	93.0%	0.0%	0.0%	0.0%	0.0%	0.0%	0.0%	0.0%	0.0%	93.1%	0.0%	0.0%	93.1%	0.0%	0.0%
<b>Trucks</b>	0	0	0	0	0	0	0	0	0	0	0	0	1	0	0	1	0	0
<b>% Trucks</b>	0.0%	0.0%	0.0%	0.0%	0.0%	0.0%	0.0%	0.0%	0.0%	0.0%	0.0%	0.0%	0.5%	0.0%	0.0%	0.5%	0.0%	0.0%
<b>Buses</b>	9	42	0	51	0	0	0	0	0	0	0	0	14	0	0	14	0	0
<b>% Buses</b>	16.1%	6.1%	0.0%	0.0%	0.0%	0.0%	0.0%	0.0%	0.0%	0.0%	0.0%	0.0%	6.5%	0.0%	0.0%	0.0%	0.0%	0.0%
<b>Pedestrians</b>	0	0	0	0	0	0	0	0	0	0	0	0	0	0	0	0	4	2
<b>% Pedestrians</b>	0.0%	0.0%	0.0%	0.0%	0.0%	0.0%	0.0%	0.0%	0.0%	0.0%	0.0%	0.0%	0.0%	0.0%	0.0%	0.0%	80.0%	100.0%
<b>% Bicycles on Crosswalk</b>	0.0%	0.0%	0.0%	0.0%	0.0%	0.0%	0.0%	0.0%	0.0%	0.0%	0.0%	0.0%	0.0%	0.0%	0.0%	0.0%	20.0%	0.0%

Turning Movement Data Plot

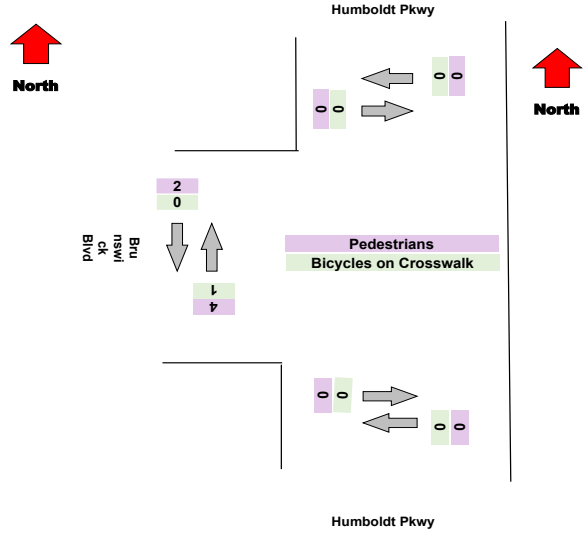
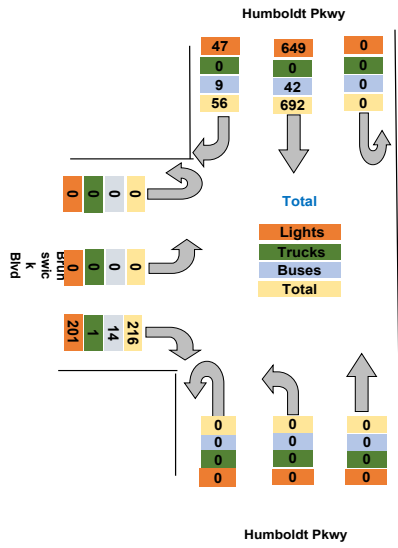

Turning Movement Peak Hour Data (AM)

7:30:00 AM

Leg Direction	Humboldt Pkwy Southbound						Humboldt Pkwy NorthBound						Brunswick Blvd Eastbound					
	Right	Thru	U-Turn	App Total	Peds CW	Peds CCW	Thru	Left	U-Turn	App Total	Peds CW	Peds CCW	Right	Left	U-Turn	App Total	Peds CW	Peds CCW
7:30:00 AM	2	39	0	41	0	0	0	0	0	0	0	0	20	0	0	20	0	0
7:45:00 AM	3	42	0	45	0	0	0	0	0	0	0	0	20	0	0	20	0	0
8:00:00 AM	2	35	0	37	0	0	0	0	0	0	0	0	14	0	0	14	0	0
8:15:00 AM	5	40	0	45	0	0	0	0	0	0	0	0	13	0	0	13	0	0
<b>Grand Total</b>	12	156	0	168	0	0	0	0	0	0	0	0	67	0	0	67	0	0
% Approach	7.1%	92.9%	0.0%	0.0%	0.0%	0.0%	14.2%	0.0%	0.0%	0.0%	0.0%	0.0%	45.1%	41.7%	0.0%	0.0%	0.0%	0.0%
% Total	5.1%	66.4%	0.0%	71.5%	0.0%	0.0%	0.0%	0.0%	0.0%	0.0%	0.0%	0.0%	28.5%	0.0%	0.0%	28.5%	0.0%	0.0%
PHF	0.600	0.929	0.000	0.933	0.000	0.000	0.000	0.000	0.000	0.000	0.000	0.000	0.838	0.000	0.000	0.838	0.000	0.000
Lights	10	147	0	157	0	0	0	0	0	0	0	0	58	0	0	58	0	0
% Lights	83.3%	94.2%	0.0%	93.5%	0.0%	0.0%	0.0%	0.0%	0.0%	0.0%	0.0%	0.0%	86.6%	0.0%	0.0%	86.6%	0.0%	0.0%
Trucks	0	0	0	0	0	0	0	0	0	0	0	0	1	0	0	1	0	0
% Trucks	0.0%	0.0%	0.0%	0.0%	0.0%	0.0%	0.0%	0.0%	0.0%	0.0%	0.0%	0.0%	1.5%	0.0%	0.0%	1.5%	0.0%	0.0%
Buses	2	9	0	11	0	0	0	0	0	0	0	0	8	0	0	8	0	0
% Buses	16.7%	5.8%	0.0%	6.5%	0.0%	0.0%	0.0%	0.0%	0.0%	0.0%	0.0%	0.0%	11.9%	0.0%	0.0%	11.9%	0.0%	0.0%
Pedestrians	0	0	0	0	0	0	0	0	0	0	0	0	0	0	0	0	0	0
% Pedestrians	0.0%	0.0%	0.0%	0.0%	0.0%	0.0%	0.0%	0.0%	0.0%	0.0%	0.0%	0.0%	0.0%	0.0%	0.0%	0.0%	0.0%	0.0%
Bicycles on Crosswalk	0	0	0	0	0	0	0	0	0	0	0	0	0	0	0	0	0	0
% Bicycles on Crosswalk	0.0%	0.0%	0.0%	0.0%	0.0%	0.0%	0.0%	0.0%	0.0%	0.0%	0.0%	0.0%	0.0%	0.0%	0.0%	0.0%	0.0%	0.0%

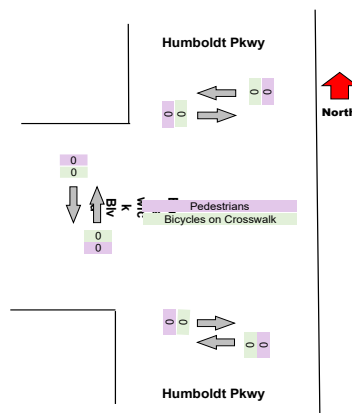
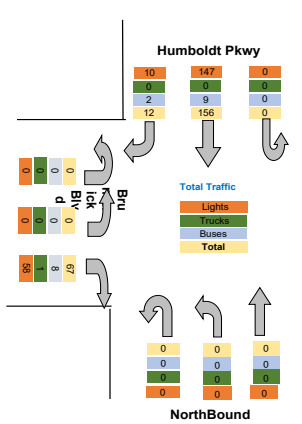

Turning Movement Peak Hour Data (PM)

4:30:00 PM

Leg Direction	Humboldt Pkwy Southbound						Humboldt Pkwy NorthBound						Brunswick Blvd Eastbound					
	Right	Thru	U-Turn	App Total	Peds CW	Peds CCW	Thru	Left	U-Turn	App Total	Peds CW	Peds CCW	Right	Left	U-Turn	App Total	Peds CW	Peds CCW
4:30:00 PM	4	67	0	71	0	0	0	0	0	0	0	0	20	0	0	20	1	0
4:45:00 PM	3	51	0	54	0	0	0	0	0	0	0	0	17	0	0	17	0	0
5:00:00 PM	7	50	0	57	0	0	0	0	0	0	0	0	14	0	0	14	1	1
5:15:00 PM	6	44	0	50	0	0	0	0	0	0	0	0	17	0	0	17	1	0
<b>Grand Total</b>	<b>20</b>	<b>212</b>	<b>0</b>	<b>232</b>	<b>0</b>	<b>0</b>	<b>0</b>	<b>0</b>	<b>0</b>	<b>0</b>	<b>0</b>	<b>0</b>	<b>68</b>	<b>0</b>	<b>0</b>	<b>68</b>	<b>3</b>	<b>1</b>
% Approach	8.6%	91.4%	0.0%	0.0%	0.0%	0.0%	14.2%	0.0%	0.0%	0.0%	0.0%	0.0%	45.1%	41.7%	0.0%	0.0%	0.0%	0.0%
% Total	6.7%	70.7%	0.0%	77.3%	0.0%	0.0%	0.0%	0.0%	0.0%	0.0%	0.0%	0.0%	22.7%	0.0%	0.0%	22.7%	0.0%	0.0%
PHF	0.714	0.791	0.000	0.817	0.000	0.000	0.000	0.000	0.000	0.000	0.000	0.000	0.850	0.000	0.000	0.850	0.000	0.000
Lights	16	200	0	216	0	0	0	0	0	0	0	0	68	0	0	66	0	0
% Lights	80.0%	94.3%	0.0%	93.1%	0.0%	0.0%	0.0%	0.0%	0.0%	0.0%	0.0%	0.0%	97.1%	0.0%	0.0%	97.1%	0.0%	0.0%
Trucks	0	0	0	0	0	0	0	0	0	0	0	0	0	0	0	0	0	0
% Trucks	0.0%	0.0%	0.0%	0.0%	0.0%	0.0%	0.0%	0.0%	0.0%	0.0%	0.0%	0.0%	0.0%	0.0%	0.0%	0.0%	0.0%	0.0%
Buses	4	11	0	15	0	0	0	0	0	0	0	0	2	0	0	2	0	0
% Buses	20.0%	5.2%	0.0%	0.0%	0.0%	0.0%	0.0%	0.0%	0.0%	0.0%	0.0%	0.0%	2.9%	0.0%	0.0%	0.0%	0.0%	0.0%
Pedestrians	0	0	0	0	0	0	0	0	0	0	0	0	0	0	0	0	2	1
% Pedestrians	0.0%	0.0%	0.0%	0.0%	0.0%	0.0%	0.0%	0.0%	0.0%	0.0%	0.0%	0.0%	0.0%	0.0%	0.0%	0.0%	66.7%	100.0%
Bicycles on Crosswalk	0	0	0	0	0	0	0	0	0	0	0	0	0	0	0	0	1	0
% Bicycles on Crosswalk	0.0%	0.0%	0.0%	0.0%	0.0%	0.0%	0.0%	0.0%	0.0%	0.0%	0.0%	0.0%	0.0%	0.0%	0.0%	0.0%	33.3%	0.0%

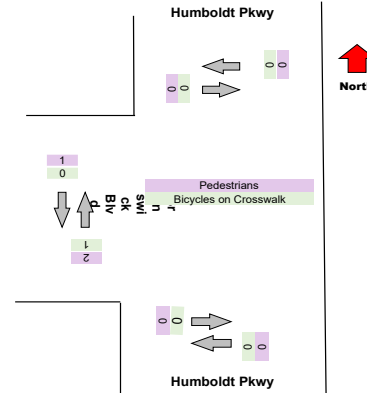
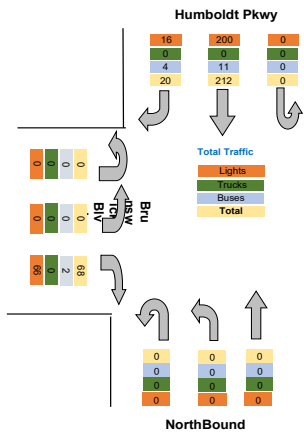

Intersection: Elm St Pine St  
 Location: Kennett Square, PA  
 Site: 01  
 Survey Date: Wednesday, 04-28-2021  
 GPS: 42.948550, -72.790034



<b>Total</b>
34
29
63
16
50
61
65
192
51
58
109
90
82
91
71
334
71
67
63
65
266
964
0.0%
0.0%
897
93.0%
1
0.1%
65
6.7%
0
0.0%
0.0%

Intersection: Elm St Pine St  
Location: Kennett Square, PA  
Site: 01  
Survey Date: Wednesday, 04-28-2021  
GPS: 42.948550, -72.790034



Total
61
65
51
58
235
0.904
215
91.5%
1
0.4%
19
8.1%
0
0.0%
0
0.0%

Intersection: Elm St Pine St  
Location: Kennett Square, PA  
Site: 01  
Survey Date: Wednesday, 04-28-2021  
GPS: 42.948550, -72.790034



Total
91
71
71
67
300
0.824
282
94.0%
0
0.0%
17
5.7%
0
0.0%
0
0.0%



Project	Labella
Project Code	Labella
Site Name	L
Legs and Movements	All Processed Legs & Movement
Bin Size	15 minutes
Survey Date	2021-10-28, Thursday
Location	L
Latitude and Longitude	42.916951, -78.843751

	Start	End	PHF
Forced Peak AM	2021/10/28 07:30:00	2021/10/28 08:30:00	0.843
Forced Peak PM	2021/10/28 16:30:00	2021/10/28 17:30:00	0.893
AM Peak	2021/10/28 07:30:00	2021/10/28 08:30:00	0.843
PM Peak	2021/10/28 16:30:00	2021/10/28 17:30:00	0.893

Turning Movement Data

Leg Direction	Humboldt Pkwy Southbound						Humboldt Pkwy Northbound						Brunswick Blvd Eastbound					
	Right	Thru	U-Turn	App Total	Peds CW	Peds CCW	Thru	Left	U-Turn	App Total	Peds CW	Peds CCW	Right	Left	U-Turn	App Total	Peds CW	Peds CCW
6:30:00 AM	0	20	0	20	0	0	0	0	0	0	0	0	4	0	0	4	0	0
6:45:00 AM	2	19	0	21	0	0	0	0	0	0	0	0	5	0	0	5	0	0
<b>Hourly Total</b>	<b>2</b>	<b>39</b>	<b>0</b>	<b>41</b>	<b>0</b>	<b>0</b>	<b>0</b>	<b>0</b>	<b>0</b>	<b>0</b>	<b>0</b>	<b>0</b>	<b>9</b>	<b>0</b>	<b>0</b>	<b>9</b>	<b>0</b>	<b>0</b>
7:00:00 AM	2	21	0	23	0	0	0	0	0	0	0	0	7	0	0	7	0	0
7:15:00 AM	3	25	0	28	0	0	0	0	0	0	0	0	11	0	0	11	0	0
7:30:00 AM	1	43	0	44	0	0	0	0	0	0	0	0	15	0	0	15	0	0
7:45:00 AM	2	52	0	54	0	0	0	0	0	0	0	0	16	0	0	16	2	0
<b>Hourly Total</b>	<b>8</b>	<b>141</b>	<b>0</b>	<b>149</b>	<b>0</b>	<b>0</b>	<b>0</b>	<b>0</b>	<b>0</b>	<b>0</b>	<b>0</b>	<b>0</b>	<b>49</b>	<b>0</b>	<b>0</b>	<b>49</b>	<b>2</b>	<b>0</b>
8:00:00 AM	4	39	0	43	0	0	0	0	0	0	0	0	8	0	0	8	0	0
8:15:00 AM	3	36	0	39	0	0	0	0	0	0	0	0	17	0	0	17	0	0
<b>Hourly Total</b>	<b>7</b>	<b>75</b>	<b>0</b>	<b>82</b>	<b>0</b>	<b>0</b>	<b>0</b>	<b>0</b>	<b>0</b>	<b>0</b>	<b>0</b>	<b>0</b>	<b>25</b>	<b>0</b>	<b>0</b>	<b>25</b>	<b>0</b>	<b>0</b>
4:00:00 PM	6	70	0	76	0	0	0	0	0	0	0	0	14	0	0	14	0	0
4:15:00 PM	4	66	0	70	0	0	0	0	0	0	0	0	12	0	0	12	1	1
4:30:00 PM	7	66	0	73	0	0	0	0	0	0	0	0	10	0	0	10	0	0
4:45:00 PM	7	63	0	70	0	0	0	0	0	0	0	0	21	0	0	21	1	1
<b>Hourly Total</b>	<b>24</b>	<b>265</b>	<b>0</b>	<b>289</b>	<b>0</b>	<b>0</b>	<b>0</b>	<b>0</b>	<b>0</b>	<b>0</b>	<b>0</b>	<b>0</b>	<b>57</b>	<b>0</b>	<b>0</b>	<b>57</b>	<b>2</b>	<b>2</b>
5:00:00 PM	3	54	0	57	0	0	0	0	0	0	0	0	20	0	0	20	0	1
5:15:00 PM	7	55	0	62	0	0	0	0	0	0	0	0	12	0	0	12	0	0
5:30:00 PM	2	51	0	53	0	0	0	0	0	0	0	0	14	0	0	14	1	0
5:45:00 PM	4	54	0	58	0	0	0	0	0	0	0	0	25	0	0	25	1	2
<b>Hourly Total</b>	<b>16</b>	<b>214</b>	<b>0</b>	<b>230</b>	<b>0</b>	<b>0</b>	<b>0</b>	<b>0</b>	<b>0</b>	<b>0</b>	<b>0</b>	<b>0</b>	<b>71</b>	<b>0</b>	<b>0</b>	<b>71</b>	<b>2</b>	<b>3</b>
<b>Grand Total</b>	<b>57</b>	<b>734</b>	<b>0</b>	<b>791</b>	<b>0</b>	<b>0</b>	<b>0</b>	<b>0</b>	<b>0</b>	<b>0</b>	<b>0</b>	<b>0</b>	<b>211</b>	<b>0</b>	<b>0</b>	<b>211</b>	<b>6</b>	<b>5</b>
% Approach	7.2%	92.8%	0.0%	0.0%	0.0%	0.0%	0.0%	0.0%	0.0%	0.0%	0.0%	0.0%	100.0%	0.0%	0.0%	0.0%	0.0%	0.0%
% Total	5.7%	73.3%	0.0%	78.9%	0.0%	0.0%	0.0%	0.0%	0.0%	0.0%	0.0%	0.0%	21.1%	0.0%	0.0%	21.1%	0.0%	0.0%
Lights	52	681	0	733	0	0	0	0	0	0	0	0	199	0	0	199	0	0
% Lights	91.2%	92.8%	0.0%	92.7%	0.0%	0.0%	0.0%	0.0%	0.0%	0.0%	0.0%	0.0%	94.3%	0.0%	0.0%	94.3%	0.0%	0.0%
Trucks	0	2	0	2	0	0	0	0	0	0	0	0	0	0	0	0	0	0
% Trucks	0.0%	0.3%	0.0%	0.3%	0.0%	0.0%	0.0%	0.0%	0.0%	0.0%	0.0%	0.0%	0.0%	0.0%	0.0%	0.0%	0.0%	0.0%
Buses	5	49	0	54	0	0	0	0	0	0	0	0	12	0	0	12	0	0
% Buses	8.8%	6.7%	0.0%	0.0%	0.0%	0.0%	0.0%	0.0%	0.0%	0.0%	0.0%	0.0%	5.7%	0.0%	0.0%	0.0%	0.0%	0.0%
Pedestrians	0	0	0	0	0	0	0	0	0	0	0	0	0	0	0	0	3	4
% Pedestrians	0.0%	0.0%	0.0%	0.0%	0.0%	0.0%	0.0%	0.0%	0.0%	0.0%	0.0%	0.0%	0.0%	0.0%	0.0%	0.0%	50.0%	80.0%
% Bicycles on Crosswalk	0.0%	0.0%	0.0%	0.0%	0.0%	0.0%	0.0%	0.0%	0.0%	0.0%	0.0%	0.0%	0.0%	0.0%	0.0%	0.0%	50.0%	20.0%

Turning Movement Data Plot

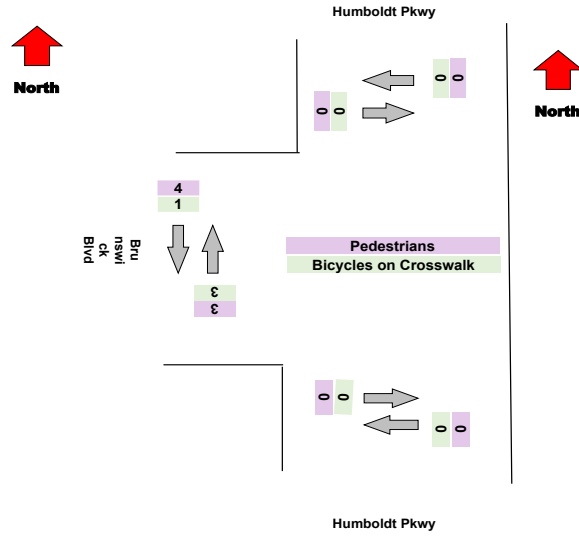
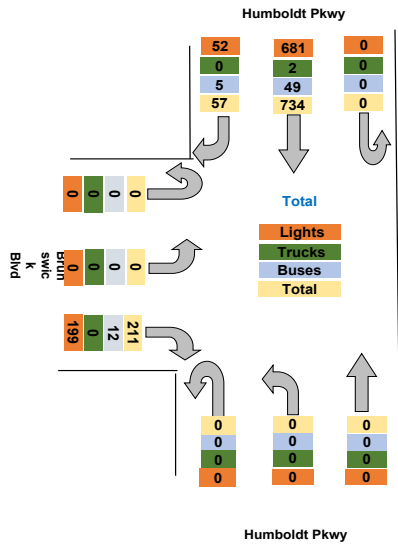

Turning Movement Peak Hour Data (AM)

7:30:00 AM

Leg Direction	Humboldt Pkwy Southbound						Humboldt Pkwy NorthBound						Brunswick Blvd Eastbound					
	Right	Thru	U-Turn	App Total	Peds CW	Peds CCW	Thru	Left	U-Turn	App Total	Peds CW	Peds CCW	Right	Left	U-Turn	App Total	Peds CW	Peds CCW
7:30:00 AM	1	43	0	44	0	0	0	0	0	0	0	0	15	0	0	15	0	0
7:45:00 AM	2	52	0	54	0	0	0	0	0	0	0	0	16	0	0	16	2	0
8:00:00 AM	4	39	0	43	0	0	0	0	0	0	0	0	8	0	0	8	0	0
8:15:00 AM	3	36	0	39	0	0	0	0	0	0	0	0	17	0	0	17	0	0
<b>Grand Total</b>	10	170	0	180	0	0	0	0	0	0	0	0	56	0	0	56	2	0
<b>% Approach</b>	5.6%	94.4%	0.0%	0.0%	0.0%	0.0%	14.2%	0.0%	0.0%	0.0%	0.0%	0.0%	45.1%	41.7%	0.0%	0.0%	0.0%	0.0%
<b>% Total</b>	4.2%	72.0%	0.0%	76.3%	0.0%	0.0%	0.0%	0.0%	0.0%	0.0%	0.0%	0.0%	23.7%	0.0%	0.0%	23.7%	0.0%	0.0%
<b>PHF</b>	0.625	0.817	0.000	0.833	0.000	0.000	0.000	0.000	0.000	0.000	0.000	0.000	0.824	0.000	0.000	0.824	0.000	0.000
<b>Lights</b>	9	160	0	169	0	0	0	0	0	0	0	0	51	0	0	51	0	0
<b>% Lights</b>	90.0%	94.1%	0.0%	93.9%	0.0%	0.0%	0.0%	0.0%	0.0%	0.0%	0.0%	0.0%	91.1%	0.0%	0.0%	91.1%	0.0%	0.0%
<b>Trucks</b>	0	1	0	1	0	0	0	0	0	0	0	0	0	0	0	0	0	0
<b>% Trucks</b>	0.0%	0.6%	0.0%	0.6%	0.0%	0.0%	0.0%	0.0%	0.0%	0.0%	0.0%	0.0%	0.0%	0.0%	0.0%	0.0%	0.0%	0.0%
<b>Buses</b>	1	9	0	10	0	0	0	0	0	0	0	0	5	0	0	5	0	0
<b>% Buses</b>	10.0%	5.3%	0.0%	0.0%	0.0%	0.0%	0.0%	0.0%	0.0%	0.0%	0.0%	0.0%	8.9%	0.0%	0.0%	0.0%	0.0%	0.0%
<b>Pedestrians</b>	0	0	0	0	0	0	0	0	0	0	0	0	0	0	0	0	2	0
<b>% Pedestrians</b>	0.0%	0.0%	0.0%	0.0%	0.0%	0.0%	0.0%	0.0%	0.0%	0.0%	0.0%	0.0%	0.0%	0.0%	0.0%	0.0%	100.0%	0.0%
<b>Bicycles on Crosswalk</b>	0	0	0	0	0	0	0	0	0	0	0	0	0	0	0	0	0	0
<b>% Bicycles on Crosswalk</b>	0.0%	0.0%	0.0%	0.0%	0.0%	0.0%	0.0%	0.0%	0.0%	0.0%	0.0%	0.0%	0.0%	0.0%	0.0%	0.0%	0.0%	0.0%

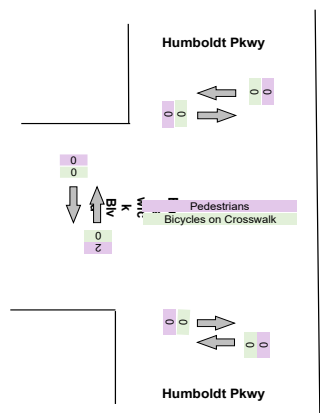
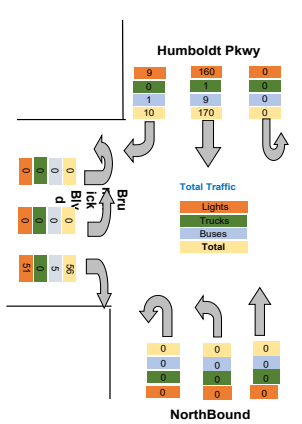

Turning Movement Peak Hour Data (PM)

4:30:00 PM

Leg Direction	Humboldt Pkwy Southbound						Humboldt Pkwy NorthBound						Brunswick Blvd Eastbound					
	Right	Thru	U-Turn	App Total	Peds CW	Peds CCW	Thru	Left	U-Turn	App Total	Peds CW	Peds CCW	Right	Left	U-Turn	App Total	Peds CW	Peds CCW
4:30:00 PM	7	66	0	73	0	0	0	0	0	0	0	0	10	0	0	10	0	0
4:45:00 PM	7	63	0	70	0	0	0	0	0	0	0	0	21	0	0	21	1	1
5:00:00 PM	3	54	0	57	0	0	0	0	0	0	0	0	20	0	0	20	0	1
5:15:00 PM	7	55	0	62	0	0	0	0	0	0	0	0	12	0	0	12	0	0
<b>Grand Total</b>	<b>24</b>	<b>238</b>	<b>0</b>	<b>262</b>	<b>0</b>	<b>0</b>	<b>0</b>	<b>0</b>	<b>0</b>	<b>0</b>	<b>0</b>	<b>0</b>	<b>63</b>	<b>0</b>	<b>0</b>	<b>63</b>	<b>1</b>	<b>2</b>
% Approach	9.2%	90.8%	0.0%	0.0%	0.0%	0.0%	14.2%	0.0%	0.0%	0.0%	0.0%	0.0%	45.1%	41.7%	0.0%	0.0%	0.0%	0.0%
% Total	7.4%	73.2%	0.0%	80.6%	0.0%	0.0%	0.0%	0.0%	0.0%	0.0%	0.0%	0.0%	19.4%	0.0%	0.0%	19.4%	0.0%	0.0%
PHF	0.857	0.902	0.000	0.897	0.000	0.000	0.000	0.000	0.000	0.000	0.000	0.000	0.750	0.000	0.000	0.750	0.000	0.000
Lights	21	219	0	240	0	0	0	0	0	0	0	0	59	0	0	59	0	0
% Lights	87.5%	92.0%	0.0%	91.6%	0.0%	0.0%	0.0%	0.0%	0.0%	0.0%	0.0%	0.0%	93.7%	0.0%	0.0%	93.7%	0.0%	0.0%
Trucks	0	1	0	1	0	0	0	0	0	0	0	0	0	0	0	0	0	0
% Trucks	0.0%	0.4%	0.0%	0.4%	0.0%	0.0%	0.0%	0.0%	0.0%	0.0%	0.0%	0.0%	0.0%	0.0%	0.0%	0.0%	0.0%	0.0%
Buses	3	16	0	19	0	0	0	0	0	0	0	0	4	0	0	4	0	0
% Buses	12.5%	6.7%	0.0%	0.0%	0.0%	0.0%	0.0%	0.0%	0.0%	0.0%	0.0%	0.0%	6.3%	0.0%	0.0%	0.0%	0.0%	0.0%
Pedestrians	0	0	0	0	0	0	0	0	0	0	0	0	0	0	0	0	0	2
% Pedestrians	0.0%	0.0%	0.0%	0.0%	0.0%	0.0%	0.0%	0.0%	0.0%	0.0%	0.0%	0.0%	0.0%	0.0%	0.0%	0.0%	0.0%	100.0%
Bicycles on Crosswalk	0	0	0	0	0	0	0	0	0	0	0	0	0	0	0	0	1	0
% Bicycles on Crosswalk	0.0%	0.0%	0.0%	0.0%	0.0%	0.0%	0.0%	0.0%	0.0%	0.0%	0.0%	0.0%	0.0%	0.0%	0.0%	0.0%	100.0%	0.0%

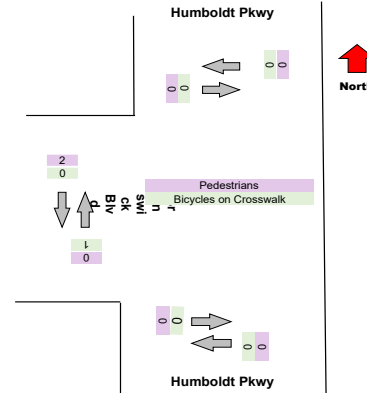
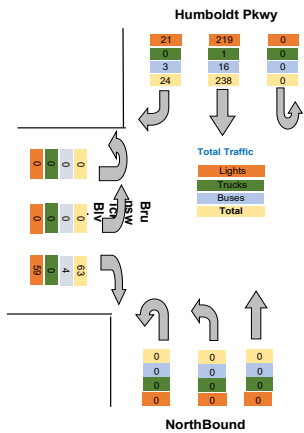

Intersection: Elm St Pine St  
 Location: Kennett Square, PA  
 Site: 01  
 Survey Date: Wednesday, 04-28-2021  
 GPS: 42.948550, -72.790034



<b>Total</b>
24
26
50
30
39
59
70
198
51
56
107
90
82
83
91
346
77
74
67
83
304
1002
0.0%
0.0%
932
93.0%
2
0.2%
66
6.6%
0
0.0%
0.0%

Intersection: Elm St Pine St  
Location: Kennett Square, PA  
Site: 01  
Survey Date: Wednesday, 04-28-2021  
GPS: 42.948550, -72.790034



Total
59
70
51
56
236
0.843
220
93.2%
1
0.4%
15
6.4%
0
0.0%
0
0.0%

Intersection: Elm St Pine St  
Location: Kennett Square, PA  
Site: 01  
Survey Date: Wednesday, 04-28-2021  
GPS: 42.948550, -72.790034



Total
83
91
77
74
325
0.893
299
92.0%
1
0.3%
23
7.1%
0
0.0%
0
0.0%





Turning Movement Data Plot

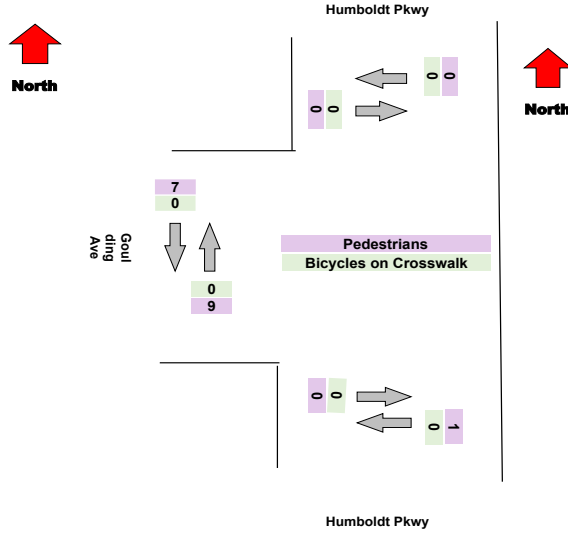
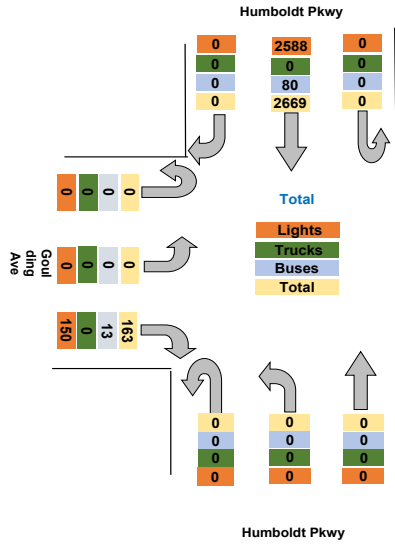

Turning Movement Peak Hour Data (AM)

7:30:00 AM

Leg Direction	Humboldt Pkwy Southbound						Humboldt Pkwy NorthBound						Goulding Ave Eastbound					
	Right	Thru	U-Turn	App Total	Peds CW	Peds CCW	Thru	Left	U-Turn	App Total	Peds CW	Peds CCW	Right	Left	U-Turn	App Total	Peds CW	Peds CCW
7:30:00 AM	0	215	0	215	0	0	0	0	0	1	0	12	0	0	13	1	0	0
7:45:00 AM	0	205	0	205	0	0	0	0	0	0	0	10	0	0	10	0	1	0
8:00:00 AM	0	164	0	164	0	0	0	0	0	0	0	12	0	0	12	0	0	0
8:15:00 AM	0	177	0	177	0	0	0	0	0	0	0	10	0	0	10	0	1	0
<b>Grand Total</b>	0	761	0	761	0	0	0	0	0	1	0	44	0	0	45	1	2	0
% Approach	0.0%	100.0%	0.0%	0.0%	0.0%	0.0%	14.2%	0.0%	0.0%	0.0%	0.0%	45.1%	41.7%	0.0%	0.0%	0.0%	0.0%	0.0%
% Total	0.0%	94.4%	0.0%	94.4%	0.0%	0.0%	0.0%	0.0%	0.0%	0.0%	0.0%	5.5%	0.0%	0.0%	5.6%	0.0%	0.0%	0.0%
PHF	0.000	0.885	0.000	0.885	0.000	0.000	0.000	0.000	0.000	0.000	0.000	0.917	0.000	0.000	0.865	0.000	0.000	0.000
Lights	0	738	0	738	0	0	0	0	0	0	0	40	0	0	40	0	0	0
% Lights	0.0%	97.0%	0.0%	97.0%	0.0%	0.0%	0.0%	0.0%	0.0%	0.0%	0.0%	90.9%	0.0%	0.0%	88.9%	0.0%	0.0%	0.0%
Trucks	0	0	0	0	0	0	0	0	0	0	0	0	0	0	0	0	0	0
% Trucks	0.0%	0.0%	0.0%	0.0%	0.0%	0.0%	0.0%	0.0%	0.0%	0.0%	0.0%	0.0%	0.0%	0.0%	0.0%	0.0%	0.0%	0.0%
Buses	0	22	0	22	0	0	0	0	0	0	0	4	0	0	4	0	0	0
% Buses	0.0%	2.9%	0.0%	0.0%	0.0%	0.0%	0.0%	0.0%	0.0%	0.0%	0.0%	9.1%	0.0%	0.0%	0.0%	0.0%	0.0%	0.0%
Pedestrians	0	0	0	0	0	0	0	0	0	1	0	0	0	0	0	1	2	0
% Pedestrians	0.0%	0.0%	0.0%	0.0%	0.0%	0.0%	0.0%	0.0%	0.0%	100.0%	0.0%	0.0%	0.0%	0.0%	0.0%	100.0%	100.0%	0.0%
Bicycles on Crosswalk	0	0	0	0	0	0	0	0	0	0	0	0	0	0	0	0	0	0
% Bicycles on Crosswalk	0.0%	0.0%	0.0%	0.0%	0.0%	0.0%	0.0%	0.0%	0.0%	0.0%	0.0%	0.0%	0.0%	0.0%	0.0%	0.0%	0.0%	0.0%

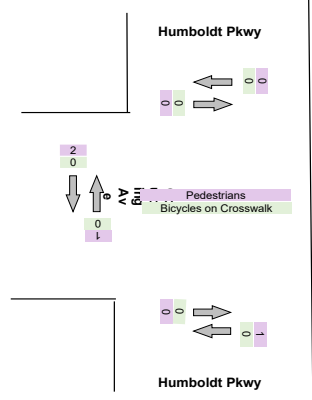
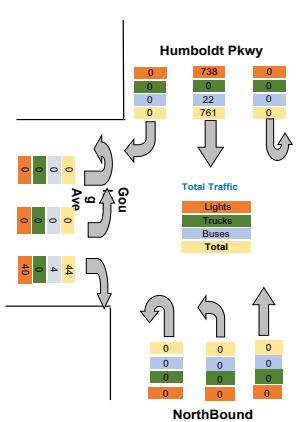

Turning Movement Peak Hour Data (PM)

4:30:00 PM

Leg Direction	Humboldt Pkwy Southbound						Humboldt Pkwy NorthBound						Goulding Ave Eastbound					
	Right	Thru	U-Turn	App	Total	Peds CW/Peds CCW	Thru	Left	U-Turn	App	Total	Peds CW/Peds CCW	Right	Left	U-Turn	App	Total	Peds CW/Peds CCW
4:30:00 PM	0	188	0	188	0	0	0	0	0	0	0	0	8	0	0	8	0	1
4:45:00 PM	0	181	0	181	0	0	0	0	0	0	0	0	6	0	0	6	0	1
5:00:00 PM	0	180	0	180	0	0	0	0	0	0	0	0	8	0	0	8	1	0
5:15:00 PM	0	167	0	167	0	0	0	0	0	0	0	0	18	0	0	18	0	0
<b>Grand Total</b>	0	716	0	716	0	0	0	0	0	0	0	0	40	0	0	40	1	2
% Approach	0.0%	100.0%	0.0%	0.0%	0.0%	0.0%	14.2%	0.0%	0.0%	0.0%	0.0%	0.0%	45.1%	41.7%	0.0%	0.0%	0.0%	0.0%
% Total	0.0%	94.7%	0.0%	94.7%	0.0%	0.0%	0.0%	0.0%	0.0%	0.0%	0.0%	0.0%	5.3%	0.0%	0.0%	5.3%	0.0%	0.0%
PHF	0.000	0.952	0.000	0.952	0.000	0.000	0.000	0.000	0.000	0.000	0.000	0.000	0.556	0.000	0.000	0.556	0.000	0.000
Lights	0	699	0	699	0	0	0	0	0	0	0	0	38	0	0	38	0	0
% Lights	0.0%	97.6%	0.0%	97.6%	0.0%	0.0%	0.0%	0.0%	0.0%	0.0%	0.0%	0.0%	95.0%	0.0%	0.0%	95.0%	0.0%	0.0%
Trucks	0	0	0	0	0	0	0	0	0	0	0	0	0	0	0	0	0	0
% Trucks	0.0%	0.0%	0.0%	0.0%	0.0%	0.0%	0.0%	0.0%	0.0%	0.0%	0.0%	0.0%	0.0%	0.0%	0.0%	0.0%	0.0%	0.0%
Buses	0	17	0	17	0	0	0	0	0	0	0	0	2	0	0	2	0	0
% Buses	0.0%	2.4%	0.0%	0.0%	0.0%	0.0%	0.0%	0.0%	0.0%	0.0%	0.0%	0.0%	5.0%	0.0%	0.0%	0.0%	0.0%	0.0%
Pedestrians	0	0	0	0	0	0	0	0	0	0	0	0	0	0	0	0	1	2
% Pedestrians	0.0%	0.0%	0.0%	0.0%	0.0%	0.0%	0.0%	0.0%	0.0%	0.0%	0.0%	0.0%	0.0%	0.0%	0.0%	0.0%	100.0%	100.0%
Bicycles on Crosswalk	0	0	0	0	0	0	0	0	0	0	0	0	0	0	0	0	0	0
% Bicycles on Crosswalk	0.0%	0.0%	0.0%	0.0%	0.0%	0.0%	0.0%	0.0%	0.0%	0.0%	0.0%	0.0%	0.0%	0.0%	0.0%	0.0%	0.0%	0.0%

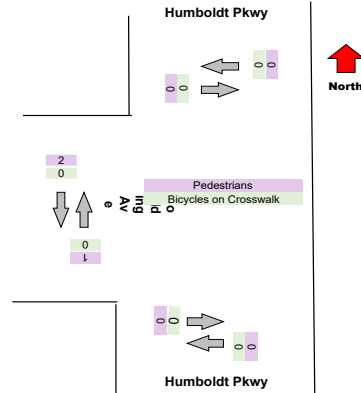
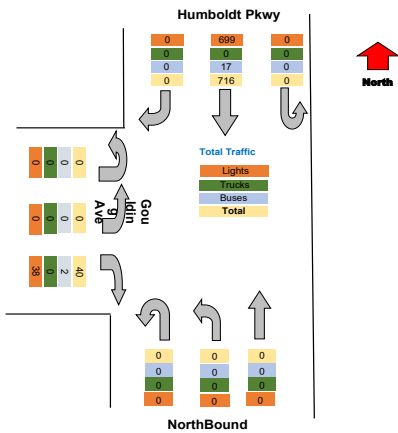

Intersection: Elm St Pine St  
 Location: Kennett Square, PA  
 Site: 01  
 Survey Date: Wednesday, 04-28-2021  
 GPS: 42.948550, -72.790034



<b>Total</b>
86
117
203
103
144
228
215
690
176
187
363
248
198
196
187
829
188
185
211
164
748
2833
0.0%
0.0%
2738
96.6%
0
0.0%
93
3.3%
0
0.0%
0.0%

Intersection: Elm St Pine St  
Location: Kennett Square, PA  
Site: 01  
Survey Date: Wednesday, 04-28-2021  
GPS: 42.948550, -72.790034



Total
228
215
176
187
806
0.884
778
96.5%
0
0.0%
26
3.2%
0
0.0%
0
0.0%

Intersection: Elm St Pine St  
Location: Kennett Square, PA  
Site: 01  
Survey Date: Wednesday, 04-28-2021  
GPS: 42.948550, -72.790034



Total
196
187
188
185
756
0.964
737
97.5%
0
0.0%
19
2.5%
0
0.0%
0
0.0%

Project	Labella
Project Code	Labella
Site Name	M
Legs and Movements	All Processed Legs & Movements
Bin Size	15 minutes
Survey Date	2021-10-27, Wednesday
Location	M
Latitude and Longitude	42.915437, -78.843689

	Start	End	PHF
Forced Peak AM	2021/10/27 07:30:00	2021/10/27 08:30:00	0.886
Forced Peak PM	2021/10/27 16:30:00	2021/10/27 17:30:00	0.932
AM Peak	2021/10/27 07:30:00	2021/10/27 08:30:00	0.886
PM Peak	2021/10/27 16:30:00	2021/10/27 17:30:00	0.932

Turning Movement Data

Leg	Humboldt Pkwy						Humboldt Pkwy						Goulding Ave					
	Southbound						NorthBound						Eastbound					
Direction	Right	Thru	U-Turn	App Total	Peds CW	Peds CCW	Thru	Left	U-Turn	App Total	Peds CW	Peds CCW	Right	Left	U-Turn	App Total	Peds CW	Peds CCW
Start Time																		
6:30:00 AM	0	95	0	95	0	0	0	0	0	0	0	0	4	0	0	4	1	1
6:45:00 AM	0	106	0	106	0	0	0	0	0	0	0	1	3	0	0	4	1	1
<b>Hourly Total</b>	0	201	0	201	0	0	0	0	0	0	0	1	7	0	0	8	2	2
7:00:00 AM	0	81	0	81	0	0	0	0	0	0	0	0	6	0	0	6	0	1
7:15:00 AM	0	181	0	181	0	0	0	0	0	0	0	0	12	0	0	12	1	1
7:30:00 AM	0	208	0	208	0	0	0	0	0	0	0	0	11	0	0	11	0	1
7:45:00 AM	0	232	0	232	0	0	0	0	0	0	0	0	8	0	0	8	0	0
<b>Hourly Total</b>	0	702	0	702	0	0	0	0	0	0	0	0	37	0	0	37	1	3
8:00:00 AM	0	206	0	206	0	0	0	0	0	0	0	0	7	0	0	7	0	0
8:15:00 AM	0	173	0	173	0	0	0	0	0	0	0	0	6	0	0	6	0	0
<b>Hourly Total</b>	0	379	0	379	0	0	0	0	0	0	0	0	13	0	0	13	0	0
4:00:00 PM	0	209	0	209	0	0	0	0	0	0	0	0	13	0	0	13	1	1
4:15:00 PM	0	225	0	225	0	0	0	0	0	0	0	0	12	0	0	12	1	1
4:30:00 PM	0	196	0	196	0	0	0	0	0	0	0	0	15	0	0	15	2	0
4:45:00 PM	0	211	0	211	0	0	0	0	0	0	1	0	9	0	0	9	2	1
<b>Hourly Total</b>	0	841	0	841	0	0	0	0	0	0	1	0	49	0	0	49	6	3
5:00:00 PM	0	174	0	174	0	0	0	0	0	0	0	0	10	0	0	10	1	1
5:15:00 PM	0	190	0	190	0	0	0	0	0	0	0	0	15	0	0	15	3	0
5:30:00 PM	0	188	0	188	0	0	0	0	0	0	0	0	13	0	0	13	0	0
5:45:00 PM	0	194	0	194	0	0	0	0	0	0	0	0	11	0	0	11	0	0
<b>Hourly Total</b>	0	746	0	746	0	0	0	0	0	0	0	0	49	0	0	49	4	1
<b>Grand Total</b>	0	2869	0	2869	0	0	0	0	0	0	1	1	155	0	0	156	13	9
% Approach	0.0%	100.0%	0.0%	0.0%	0.0%	0.0%	0.0%	0.0%	0.0%	0.0%	0.0%	0.0%	99.4%	0.0%	0.0%	0.0%	0.0%	0.0%
% Total	0.0%	94.8%	0.0%	94.8%	0.0%	0.0%	0.0%	0.0%	0.0%	0.0%	0.0%	0.0%	5.1%	0.0%	0.0%	5.2%	0.0%	0.0%
Lights	0	2790	0	2790	0	0	0	0	0	0	0	0	143	0	0	143	0	0
% Lights	0.0%	97.2%	0.0%	97.2%	0.0%	0.0%	0.0%	0.0%	0.0%	0.0%	0.0%	0.0%	92.3%	0.0%	0.0%	91.7%	0.0%	0.0%
Trucks	0	1	0	1	0	0	0	0	0	0	0	0	0	0	0	0	0	0
% Trucks	0.0%	0.0%	0.0%	0.0%	0.0%	0.0%	0.0%	0.0%	0.0%	0.0%	0.0%	0.0%	0.0%	0.0%	0.0%	0.0%	0.0%	0.0%
Buses	0	77	0	77	0	0	0	0	0	0	0	0	12	0	0	12	0	0
% Buses	0.0%	2.7%	0.0%	0.0%	0.0%	0.0%	0.0%	0.0%	0.0%	0.0%	0.0%	0.0%	7.7%	0.0%	0.0%	0.0%	0.0%	0.0%
Pedestrians	0	0	0	0	0	0	0	0	0	0	1	1	0	0	0	0	11	9
% Pedestrians	0.0%	0.0%	0.0%	0.0%	0.0%	0.0%	0.0%	0.0%	0.0%	0.0%	100.0%	100.0%	0.0%	0.0%	0.0%	0.0%	84.6%	100.0%
% Bicycles on Crosswalk	0.0%	0.0%	0.0%	0.0%	0.0%	0.0%	0.0%	0.0%	0.0%	0.0%	0.0%	0.0%	0.0%	0.0%	0.0%	0.0%	15.4%	0.0%

Turning Movement Data Plot

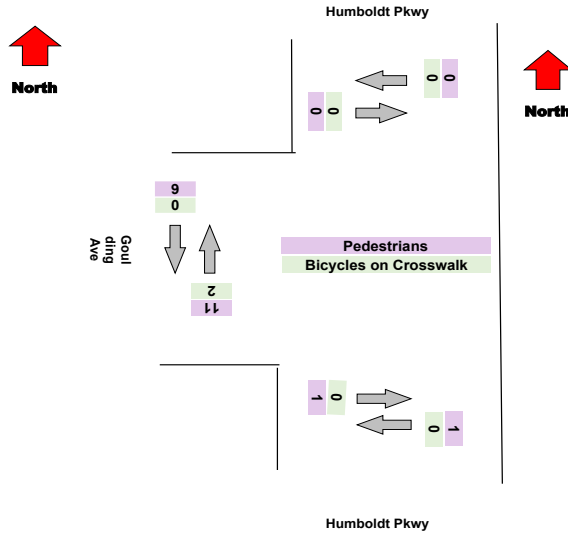
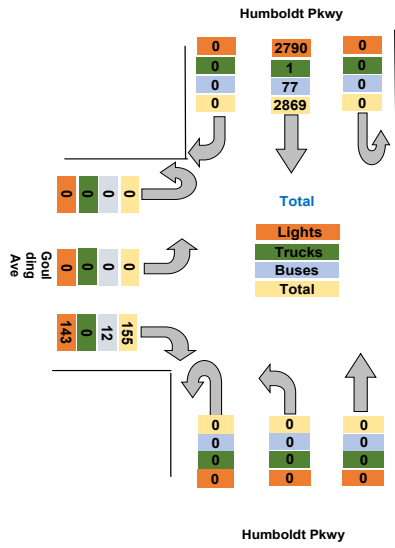



Turning Movement Peak Hour Data (AM)

7:30:00 AM

Leg Direction	Humboldt Pkwy Southbound						Humboldt Pkwy NorthBound						Goulding Ave Eastbound					
	Right	Thru	U-Turn	App Total	Peds CW	Peds CCW	Thru	Left	U-Turn	App Total	Peds CW	Peds CCW	Right	Left	U-Turn	App Total	Peds CW	Peds CCW
7:30:00 AM	0	208	0	208	0	0	0	0	0	0	0	0	11	0	0	11	0	1
7:45:00 AM	0	232	0	232	0	0	0	0	0	0	0	0	8	0	0	8	0	0
8:00:00 AM	0	206	0	206	0	0	0	0	0	0	0	0	7	0	0	7	0	0
8:15:00 AM	0	173	0	173	0	0	0	0	0	0	0	0	6	0	0	6	0	0
<b>Grand Total</b>	0	819	0	819	0	0	0	0	0	0	0	0	32	0	0	32	0	1
% Approach	0.0%	100.0%	0.0%	0.0%	0.0%	0.0%	14.2%	0.0%	0.0%	0.0%	0.0%	0.0%	45.1%	41.7%	0.0%	0.0%	0.0%	0.0%
% Total	0.0%	96.2%	0.0%	96.2%	0.0%	0.0%	0.0%	0.0%	0.0%	0.0%	0.0%	0.0%	3.8%	0.0%	0.0%	3.8%	0.0%	0.0%
PHF	0.000	0.883	0.000	0.883	0.000	0.000	0.000	0.000	0.000	0.000	0.000	0.000	0.727	0.000	0.000	0.727	0.000	0.000
Lights	0	799	0	799	0	0	0	0	0	0	0	0	27	0	0	27	0	0
% Lights	0.0%	97.6%	0.0%	97.6%	0.0%	0.0%	0.0%	0.0%	0.0%	0.0%	0.0%	0.0%	84.4%	0.0%	0.0%	84.4%	0.0%	0.0%
Trucks	0	0	0	0	0	0	0	0	0	0	0	0	0	0	0	0	0	0
% Trucks	0.0%	0.0%	0.0%	0.0%	0.0%	0.0%	0.0%	0.0%	0.0%	0.0%	0.0%	0.0%	0.0%	0.0%	0.0%	0.0%	0.0%	0.0%
Buses	0	20	0	20	0	0	0	0	0	0	0	0	5	0	0	5	0	0
% Buses	0.0%	2.4%	0.0%	0.0%	0.0%	0.0%	0.0%	0.0%	0.0%	0.0%	0.0%	0.0%	15.6%	0.0%	0.0%	0.0%	0.0%	0.0%
Pedestrians	0	0	0	0	0	0	0	0	0	0	0	0	0	0	0	0	0	1
% Pedestrians	0.0%	0.0%	0.0%	0.0%	0.0%	0.0%	0.0%	0.0%	0.0%	0.0%	0.0%	0.0%	0.0%	0.0%	0.0%	0.0%	0.0%	100.0%
Bicycles on Crosswalk	0	0	0	0	0	0	0	0	0	0	0	0	0	0	0	0	0	0
% Bicycles on Crosswalk	0.0%	0.0%	0.0%	0.0%	0.0%	0.0%	0.0%	0.0%	0.0%	0.0%	0.0%	0.0%	0.0%	0.0%	0.0%	0.0%	0.0%	0.0%

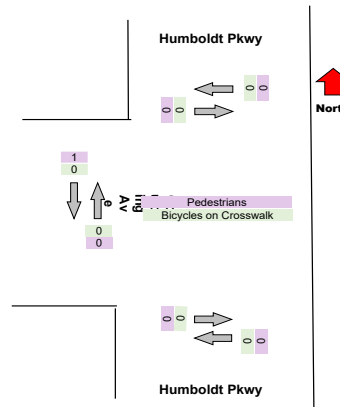
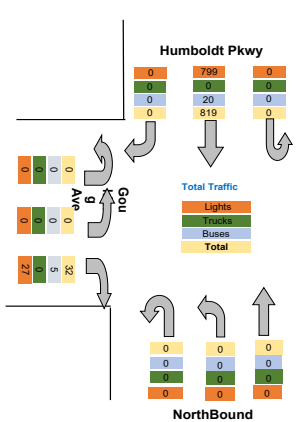

Turning Movement Peak Hour Data (PM)

4:30:00 PM

Leg Direction	Humboldt Pkwy Southbound						Humboldt Pkwy NorthBound						Goulding Ave Eastbound					
	Right	Thru	U-Turn	App	Total	Peds CW/Peds CCW	Thru	Left	U-Turn	App	Total	Peds CW/Peds CCW	Right	Left	U-Turn	App	Total	Peds CW/Peds CCW
4:30:00 PM	0	196	0	196	0	0	0	0	0	0	0	0	15	0	0	15	2	0
4:45:00 PM	0	211	0	211	0	0	0	0	0	1	0	0	9	0	0	9	2	1
5:00:00 PM	0	174	0	174	0	0	0	0	0	0	0	0	10	0	0	10	1	1
5:15:00 PM	0	190	0	190	0	0	0	0	0	0	0	0	15	0	0	15	3	0
<b>Grand Total</b>	0	771	0	771	0	0	0	0	0	1	0	0	49	0	0	49	8	2
% Approach	0.0%	100.0%	0.0%	0.0%	0.0%	0.0%	14.2%	0.0%	0.0%	0.0%	0.0%	0.0%	45.1%	41.7%	0.0%	0.0%	0.0%	0.0%
% Total	0.0%	94.0%	0.0%	94.0%	0.0%	0.0%	0.0%	0.0%	0.0%	0.0%	0.0%	0.0%	6.0%	0.0%	0.0%	6.0%	0.0%	0.0%
PHF	0.000	0.914	0.000	0.914	0.000	0.000	0.000	0.000	0.000	0.000	0.000	0.000	0.817	0.000	0.000	0.817	0.000	0.000
Lights	0	755	0	755	0	0	0	0	0	0	0	0	46	0	0	46	0	0
% Lights	0.0%	97.9%	0.0%	97.9%	0.0%	0.0%	0.0%	0.0%	0.0%	0.0%	0.0%	0.0%	93.9%	0.0%	0.0%	93.9%	0.0%	0.0%
Trucks	0	0	0	0	0	0	0	0	0	0	0	0	0	0	0	0	0	0
% Trucks	0.0%	0.0%	0.0%	0.0%	0.0%	0.0%	0.0%	0.0%	0.0%	0.0%	0.0%	0.0%	0.0%	0.0%	0.0%	0.0%	0.0%	0.0%
Buses	0	16	0	16	0	0	0	0	0	0	0	0	3	0	0	3	0	0
% Buses	0.0%	2.1%	0.0%	0.0%	0.0%	0.0%	0.0%	0.0%	0.0%	0.0%	0.0%	0.0%	6.1%	0.0%	0.0%	0.0%	0.0%	0.0%
Pedestrians	0	0	0	0	0	0	0	0	0	1	0	0	0	0	0	0	6	2
% Pedestrians	0.0%	0.0%	0.0%	0.0%	0.0%	0.0%	0.0%	0.0%	0.0%	100.0%	0.0%	0.0%	0.0%	0.0%	0.0%	0.0%	75.0%	100.0%
Bicycles on Crosswalk	0	0	0	0	0	0	0	0	0	0	0	0	0	0	0	0	2	0
% Bicycles on Crosswalk	0.0%	0.0%	0.0%	0.0%	0.0%	0.0%	0.0%	0.0%	0.0%	0.0%	0.0%	0.0%	0.0%	0.0%	0.0%	0.0%	25.0%	0.0%

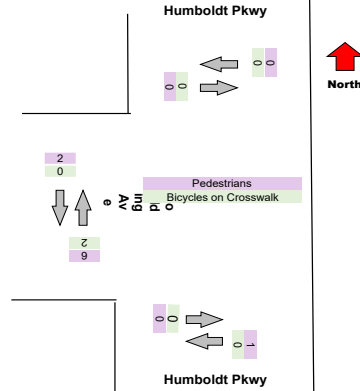
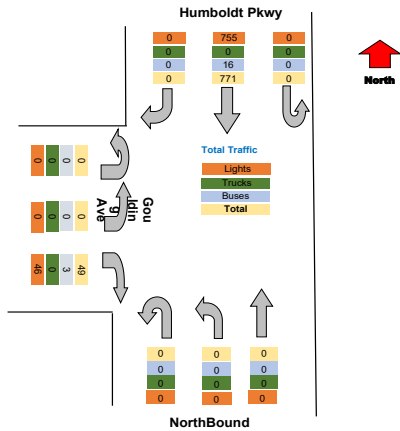

Intersection: Elm St Pine St  
 Location: Kennett Square, PA  
 Site: 01  
 Survey Date: Wednesday, 04-28-2021  
 GPS: 42.948550, -72.790034



<b>Total</b>
99
110
209
87
193
219
240
739
213
179
392
222
237
211
220
890
184
205
201
205
795
3025
0.0%
0.0%
2933
97.0%
1
0.0%
89
2.9%
0
0.0%
0.0%

Intersection: Elm St Pine St  
Location: Kennett Square, PA  
Site: 01  
Survey Date: Wednesday, 04-28-2021  
GPS: 42.948550, -72.790034



Total
219
240
213
179
851
0.886
826
97.1%
0
0.0%
25
2.9%
0
0.0%
0
0.0%

Intersection: Elm St Pine St  
Location: Kennett Square, PA  
Site: 01  
Survey Date: Wednesday, 04-28-2021  
GPS: 42.948550, -72.790034



Total
211
220
184
205
820
0.932
801
97.7%
0
0.0%
19
2.3%
0
0.0%
0
0.0%

Project	Labella
Project Code	Labella
Site Name	M
Legs and Movements	All Processed Legs & Movements
Bin Size	15 minutes
Survey Date	2021-10-28, Thursday
Location	M
Latitude and Longitude	42.915437, -78.843689

	Start	End	PHF
Forced Peak AM	2021/10/28 07:30:00	2021/10/28 08:30:00	0.875
Forced Peak PM	2021/10/28 16:30:00	2021/10/28 17:30:00	0.955
AM Peak	2021/10/28 07:30:00	2021/10/28 08:30:00	0.875
PM Peak	2021/10/28 16:30:00	2021/10/28 17:30:00	0.955

Turning Movement Data

Leg Direction	Humboldt Pkwy Southbound						Humboldt Pkwy NorthBound						Goulding Ave Eastbound						
	Right	Thru	U-Turn	App Total	Peds CW	Peds CCW	Thru	Left	U-Turn	App Total	Peds CW	Peds CCW	Right	Left	U-Turn	App Total	Peds CW	Peds CCW	
Start Time																			
6:30:00 AM	0	80	0	80	0	0	0	0	0	0	0	0	4	0	0	4	1	0	
6:45:00 AM	0	112	0	112	0	0	0	0	0	0	0	0	7	0	0	7	0	0	
<b>Hourly Total</b>	0	192	0	192	0	0	0	0	0	0	0	0	11	0	0	11	1	0	
7:00:00 AM	0	88	0	88	0	0	0	0	0	0	1	4	0	0	5	0	0		
7:15:00 AM	0	137	0	137	0	0	0	0	0	0	0	4	0	0	4	1	1		
7:30:00 AM	0	212	0	212	0	0	0	0	0	0	0	10	0	0	10	2	0		
7:45:00 AM	0	244	0	244	0	0	0	0	0	0	0	11	0	0	11	0	0		
<b>Hourly Total</b>	0	681	0	681	0	0	0	0	0	0	1	29	0	0	30	3	1		
8:00:00 AM	0	210	0	210	0	0	0	0	0	0	0	9	0	0	9	0	1		
8:15:00 AM	0	186	0	186	0	0	0	0	0	0	0	11	0	0	11	0	0		
<b>Hourly Total</b>	0	396	0	396	0	0	0	0	0	0	0	20	0	0	20	0	1		
4:00:00 PM	1	205	0	206	0	0	0	0	0	0	0	17	0	0	17	0	0		
4:15:00 PM	0	229	0	229	0	0	0	0	0	0	0	15	0	0	15	1	2		
4:30:00 PM	0	223	0	223	0	0	0	0	0	0	0	10	0	0	10	1	0		
4:45:00 PM	0	202	0	202	0	0	0	0	0	0	0	19	0	0	19	1	3		
<b>Hourly Total</b>	1	859	0	860	0	0	0	0	0	0	0	61	0	0	61	3	5		
5:00:00 PM	0	206	0	206	0	0	0	0	0	0	0	15	0	0	15	0	1		
5:15:00 PM	0	201	0	201	0	0	0	0	0	0	0	14	0	0	14	0	0		
5:30:00 PM	0	215	0	215	0	0	0	0	0	0	0	17	0	0	17	1	0		
5:45:00 PM	0	201	0	201	0	0	0	0	0	0	0	10	0	0	10	1	2		
<b>Hourly Total</b>	0	823	0	823	0	0	0	0	0	0	0	56	0	0	56	2	3		
<b>Grand Total</b>	1	2951	0	2952	0	0	0	0	0	0	1	177	0	0	178	9	10		
% Approach	0.0%	100.0%	0.0%	0.0%	0.0%	0.0%	0.0%	0.0%	0.0%	0.0%	0.0%	99.4%	0.0%	0.0%	0.0%	0.0%	0.0%		
% Total	0.0%	94.3%	0.0%	94.3%	0.0%	0.0%	0.0%	0.0%	0.0%	0.0%	0.0%	5.7%	0.0%	0.0%	5.7%	0.0%	0.0%		
Lights	1	2866	0	2867	0	0	0	0	0	0	0	165	0	0	165	0	0		
% Lights	100.0%	97.1%	0.0%	97.1%	0.0%	0.0%	0.0%	0.0%	0.0%	0.0%	0.0%	93.2%	0.0%	0.0%	92.7%	0.0%	0.0%		
Trucks	0	2	0	2	0	0	0	0	0	0	0	0	0	0	0	0	0		
% Trucks	0.0%	0.1%	0.0%	0.1%	0.0%	0.0%	0.0%	0.0%	0.0%	0.0%	0.0%	0.0%	0.0%	0.0%	0.0%	0.0%	0.0%		
Buses	0	80	0	80	0	0	0	0	0	0	0	12	0	0	12	0	0		
% Buses	0.0%	2.7%	0.0%	0.0%	0.0%	0.0%	0.0%	0.0%	0.0%	0.0%	0.0%	6.8%	0.0%	0.0%	0.0%	0.0%	0.0%		
Pedestrians	0	0	0	0	0	0	0	0	0	0	1	0	0	0	0	5	9		
% Pedestrians	0.0%	0.0%	0.0%	0.0%	0.0%	0.0%	0.0%	0.0%	0.0%	0.0%	100.0%	0.0%	0.0%	0.0%	0.0%	55.6%	90.0%		
% Bicycles on Crosswalk	0.0%	0.0%	0.0%	0.0%	0.0%	0.0%	0.0%	0.0%	0.0%	0.0%	0.0%	0.0%	0.0%	0.0%	0.0%	44.4%	10.0%		

Turning Movement Data Plot

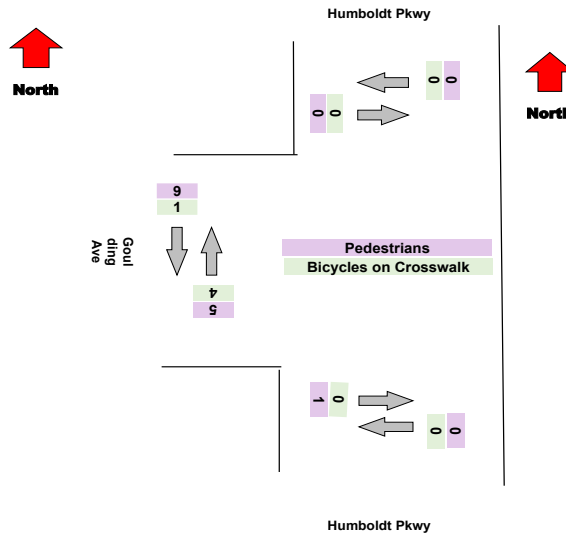
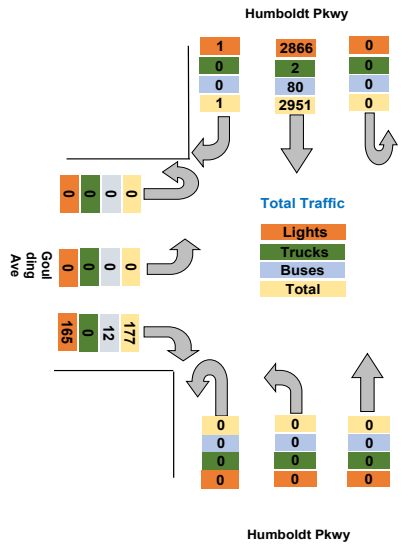

Turning Movement Peak Hour Data (AM)

7:30:00 AM

Leg Direction	Humboldt Pkwy Southbound						Humboldt Pkwy Northbound						Goulding Ave Eastbound					
	Right	Thru	U-Turn	App Total	Peds CW	Peds CCW	Thru	Left	U-Turn	App Total	Peds CW	Peds CCW	Right	Left	U-Turn	App Total	Peds CW	Peds CCW
7:30:00 AM	0	212	0	212	0	0	0	0	0	0	0	0	10	0	0	10	2	0
7:45:00 AM	0	244	0	244	0	0	0	0	0	0	0	0	11	0	0	11	0	0
8:00:00 AM	0	210	0	210	0	0	0	0	0	0	0	0	9	0	0	9	0	1
8:15:00 AM	0	186	0	186	0	0	0	0	0	0	0	0	11	0	0	11	0	0
<b>Grand Total</b>	0	852	0	852	0	0	0	0	0	0	0	0	41	0	0	41	2	1
% Approach	0.0%	100.0%	0.0%	0.0%	0.0%	0.0%	14.2%	0.0%	0.0%	0.0%	0.0%	0.0%	45.1%	41.7%	0.0%	0.0%	0.0%	0.0%
% Total	0.0%	95.4%	0.0%	95.4%	0.0%	0.0%	0.0%	0.0%	0.0%	0.0%	0.0%	0.0%	4.6%	0.0%	0.0%	4.6%	0.0%	0.0%
PHF	0.000	0.873	0.000	0.873	0.000	0.000	0.000	0.000	0.000	0.000	0.000	0.000	0.932	0.000	0.000	0.932	0.000	0.000
Lights	0	828	0	828	0	0	0	0	0	0	0	0	37	0	0	37	0	0
% Lights	0.0%	97.2%	0.0%	97.2%	0.0%	0.0%	0.0%	0.0%	0.0%	0.0%	0.0%	0.0%	90.2%	0.0%	0.0%	90.2%	0.0%	0.0%
Trucks	0	1	0	1	0	0	0	0	0	0	0	0	0	0	0	0	0	0
% Trucks	0.0%	0.1%	0.0%	0.1%	0.0%	0.0%	0.0%	0.0%	0.0%	0.0%	0.0%	0.0%	0.0%	0.0%	0.0%	0.0%	0.0%	0.0%
Buses	0	23	0	23	0	0	0	0	0	0	0	0	4	0	0	4	0	0
% Buses	0.0%	2.7%	0.0%	2.7%	0.0%	0.0%	0.0%	0.0%	0.0%	0.0%	0.0%	0.0%	9.8%	0.0%	0.0%	9.8%	0.0%	0.0%
Pedestrians	0	0	0	0	0	0	0	0	0	0	0	0	0	0	0	0	2	1
% Pedestrians	0.0%	0.0%	0.0%	0.0%	0.0%	0.0%	0.0%	0.0%	0.0%	0.0%	0.0%	0.0%	0.0%	0.0%	0.0%	0.0%	100.0%	100.0%
Bicycles on Crosswalk	0	0	0	0	0	0	0	0	0	0	0	0	0	0	0	0	0	0
% Bicycles on Crosswalk	0.0%	0.0%	0.0%	0.0%	0.0%	0.0%	0.0%	0.0%	0.0%	0.0%	0.0%	0.0%	0.0%	0.0%	0.0%	0.0%	0.0%	0.0%

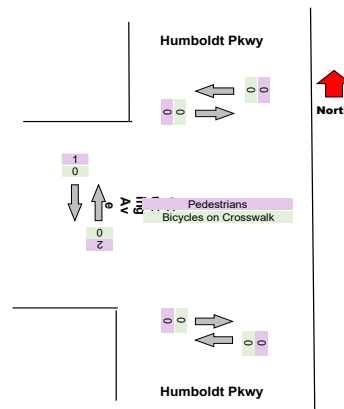
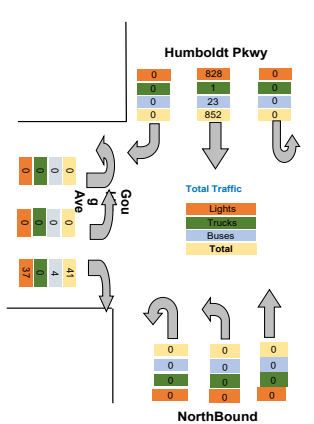



Turning Movement Peak Hour Data (PM)

4:30:00 PM

Leg Direction	Humboldt Pkwy Southbound					Humboldt Pkwy NorthBound					Goulding Ave Eastbound							
	Right	Thru	U-Turn	App Total	Peds CW	Peds CCW	Thru	Left	U-Turn	App Total	Peds CW	Peds CCW	Right	Left	U-Turn	App Total	Peds CW	Peds CCW
4:30:00 PM	0	223	0	223	0	0	0	0	0	0	0	0	10	0	0	10	1	0
4:45:00 PM	0	202	0	202	0	0	0	0	0	0	0	0	19	0	0	19	1	3
5:00:00 PM	0	206	0	206	0	0	0	0	0	0	0	0	15	0	0	15	0	1
5:15:00 PM	0	201	0	201	0	0	0	0	0	0	0	0	14	0	0	14	0	0
<b>Grand Total</b>	0	832	0	832	0	0	0	0	0	0	0	0	58	0	0	58	2	4
% Approach	0.0%	100.0%	0.0%	0.0%	0.0%	0.0%	14.2%	0.0%	0.0%	0.0%	0.0%	0.0%	45.1%	41.7%	0.0%	0.0%	0.0%	0.0%
% Total	0.0%	93.5%	0.0%	93.5%	0.0%	0.0%	0.0%	0.0%	0.0%	0.0%	0.0%	0.0%	6.5%	0.0%	0.0%	6.5%	0.0%	0.0%
PHF	0.000	0.933	0.000	0.933	0.000	0.000	0.000	0.000	0.000	0.000	0.000	0.000	0.763	0.000	0.000	0.763	0.000	0.000
Lights	0	809	0	809	0	0	0	0	0	0	0	0	55	0	0	55	0	0
% Lights	0.0%	97.2%	0.0%	97.2%	0.0%	0.0%	0.0%	0.0%	0.0%	0.0%	0.0%	0.0%	94.8%	0.0%	0.0%	94.8%	0.0%	0.0%
Trucks	0	1	0	1	0	0	0	0	0	0	0	0	0	0	0	0	0	0
% Trucks	0.0%	0.1%	0.0%	0.1%	0.0%	0.0%	0.0%	0.0%	0.0%	0.0%	0.0%	0.0%	0.0%	0.0%	0.0%	0.0%	0.0%	0.0%
Buses	0	21	0	21	0	0	0	0	0	0	0	0	3	0	0	3	0	0
% Buses	0.0%	2.5%	0.0%	0.0%	0.0%	0.0%	0.0%	0.0%	0.0%	0.0%	0.0%	0.0%	5.2%	0.0%	0.0%	0.0%	0.0%	0.0%
Pedestrians	0	0	0	0	0	0	0	0	0	0	0	0	0	0	0	0	0	3
% Pedestrians	0.0%	0.0%	0.0%	0.0%	0.0%	0.0%	0.0%	0.0%	0.0%	0.0%	0.0%	0.0%	0.0%	0.0%	0.0%	0.0%	0.0%	75.0%
Bicycles on Crosswalk	0	0	0	0	0	0	0	0	0	0	0	0	0	0	0	0	2	1
% Bicycles on Crosswalk	0.0%	0.0%	0.0%	0.0%	0.0%	0.0%	0.0%	0.0%	0.0%	0.0%	0.0%	0.0%	0.0%	0.0%	0.0%	0.0%	100.0%	25.0%

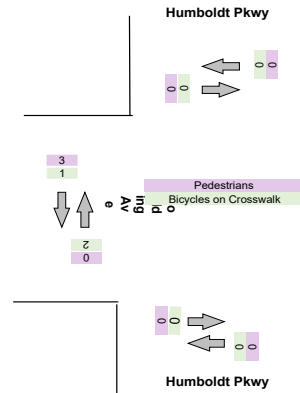
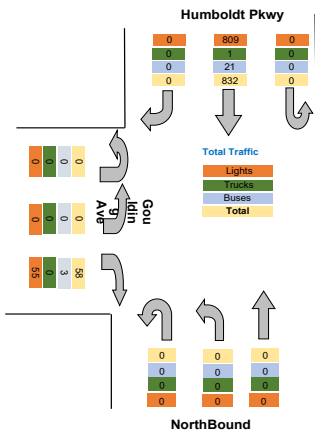

Intersection: Elm St Pine St  
 Location: Kennett Square, PA  
 Site: 01  
 Survey Date: Wednesday, 04-28-2021  
 GPS: 42.948550, -72.790034



<b>Total</b>
84
119
203
93
141
222
255
711
219
197
416
223
244
233
221
921
221
215
232
211
879
3130
0.0%
0.0%
3032
96.9%
2
0.1%
92
2.9%
0
0.0%
0.0%

Intersection: Elm St Pine St  
Location: Kennett Square, PA  
Site: 01  
Survey Date: Wednesday, 04-28-2021  
GPS: 42.948550, -72.790034



Total
222
255
219
197
893
0.875
865
96.9%
1
0.1%
27
3.0%
0
0.0%
0
0.0%

Intersection: Elm St Pine St  
Location: Kennett Square, PA  
Site: 01  
Survey Date: Wednesday, 04-28-2021  
GPS: 42.948550, -72.790034



Total
233
221
221
215
890
0.955
864
97.1%
1
0.1%
24
2.7%
0
0.0%
0
0.0%



Turning Movement Data Plot

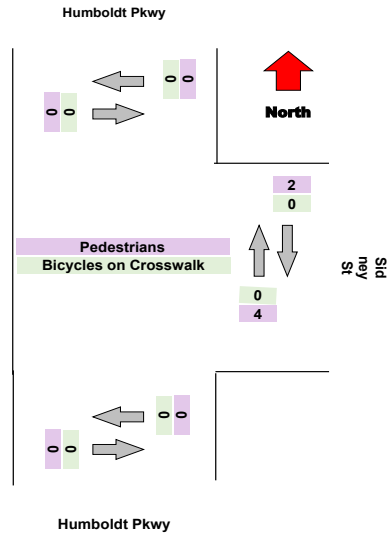
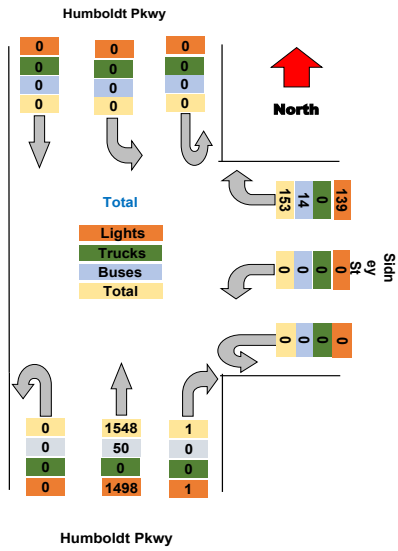

Turning Movement Peak Hour Data (AM)

7:30:00 AM

Leg	Humboldt Pkwy						Sidney St						Humboldt Pkwy						Total			
	Southbound						Westbound						Northbound									
Direction	Thru	Left	U-Turn	App	Total	Peds CW	Peds CCW	Right	Left	U-Turn	App	Total	Peds CW	Peds CCW	Right	Thru	U-Turn	App	Total	Peds CW	Peds CCW	
7:30:00 AM	0	0	0	0	0	0	0	11	0	0	11	1	0	0	0	102	0	0	103	0	0	114
7:45:00 AM	0	0	0	0	0	0	0	7	0	0	7	0	1	1	0	107	0	0	108	0	0	115
8:00:00 AM	0	0	0	0	0	0	0	4	0	0	4	1	0	0	0	98	0	0	99	0	0	103
8:15:00 AM	0	0	0	0	0	0	0	9	0	0	9	0	1	1	0	94	0	0	95	0	0	104
<b>Grand Total</b>	<b>0</b>	<b>0</b>	<b>0</b>	<b>0</b>	<b>0</b>	<b>0</b>	<b>0</b>	<b>31</b>	<b>0</b>	<b>0</b>	<b>31</b>	<b>2</b>	<b>2</b>	<b>0</b>	<b>401</b>	<b>0</b>	<b>0</b>	<b>405</b>	<b>0</b>	<b>0</b>	<b>436</b>	
% Approach	#####	#####	#####	0.0%	0.0%	0.0%	0.0%	14.2%	0.0%	0.0%	0.0%	0.0%	0.0%	0.0%	45.1%	41.7%	0.0%	0.0%	0.0%	0.0%	0.0%	0.0%
% Total	0.0%	0.0%	0.0%	0.0%	0.0%	0.0%	0.0%	7.1%	0.0%	0.0%	7.1%	0.0%	0.0%	0.0%	0.0%	92.0%	0.0%	0.0%	92.9%	0.0%	0.0%	0.0%
PHF	0.000	0.000	0.000	0.000	0.000	0.000	0.000	0.705	0.000	0.000	0.705	0.000	0.000	0.000	0.000	0.937	0.000	0.000	0.938	0.000	0.000	0.948
Lights	0	0	0	0	0	0	0	30	0	0	30	0	0	0	0	388	0	0	388	0	0	418
% Lights	0.0%	0.0%	0.0%	0.0%	0.0%	0.0%	0.0%	96.8%	0.0%	0.0%	96.8%	0.0%	0.0%	0.0%	0.0%	96.8%	0.0%	0.0%	95.8%	0.0%	0.0%	95.9%
Trucks	0	0	0	0	0	0	0	0	0	0	0	0	0	0	0	0	0	0	0	0	0	0
% Trucks	0.0%	0.0%	0.0%	0.0%	0.0%	0.0%	0.0%	0.0%	0.0%	0.0%	0.0%	0.0%	0.0%	0.0%	0.0%	0.0%	0.0%	0.0%	0.0%	0.0%	0.0%	0.0%
Buses	0	0	0	0	0	0	0	1	0	0	1	0	0	0	0	13	0	0	13	0	0	14
% Buses	0.0%	0.0%	0.0%	0.0%	0.0%	0.0%	0.0%	3.2%	0.0%	0.0%	0.0%	0.0%	0.0%	0.0%	0.0%	3.2%	0.0%	0.0%	0.0%	0.0%	0.0%	3.2%
Pedestrians	0	0	0	0	0	0	0	0	0	0	0	2	2	0	0	0	0	0	0	0	0	0
% Pedestrians	0.0%	0.0%	0.0%	0.0%	0.0%	0.0%	0.0%	0.0%	0.0%	0.0%	0.0%	100.0%	100.0%	0.0%	0.0%	0.0%	0.0%	0.0%	0.0%	0.0%	0.0%	0.0%
Bicycles on Crosswalk	0	0	0	0	0	0	0	0	0	0	0	0	0	0	0	0	0	0	0	0	0	0
% Bicycles on Crosswalk	0.0%	0.0%	0.0%	0.0%	0.0%	0.0%	0.0%	0.0%	0.0%	0.0%	0.0%	0.0%	0.0%	0.0%	0.0%	0.0%	0.0%	0.0%	0.0%	0.0%	0.0%	0.0%

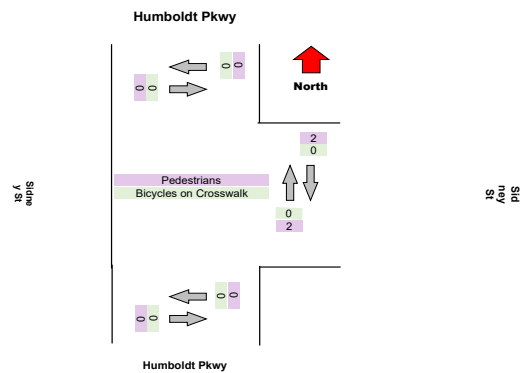
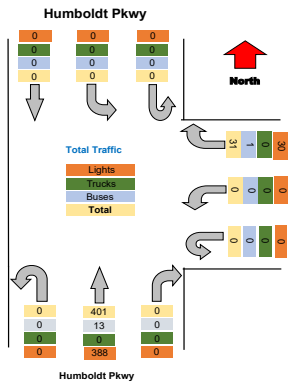

Turning Movement Peak Hour Data (PM)  
 4:30:00 PM

Leg	Humboldt Pkwy						Sidney St						Humboldt Pkwy						Total										
	Southbound						Westbound						Northbound																
Direction	Thru	Left	U-Turn	App	Total	Peds	CW	Peds	CCW	Right	Left	U-Turn	App	Total	Peds	CW	Peds	CCW	Right	Thru	U-Turn	App	Total	Peds	CW	Peds	CCW		
4:30:00 PM	0	0	0	0	0	0	0	0	0	9	0	0	9	0	0	0	0	0	0	0	115	0	115	0	0	0	0	0	0
4:45:00 PM	0	0	0	0	0	0	0	0	0	15	0	0	15	0	0	0	0	0	0	0	91	0	91	0	0	0	0	0	0
5:00:00 PM	0	0	0	0	0	0	0	0	0	9	0	0	9	0	1	0	0	0	0	0	105	0	105	0	0	0	0	0	0
5:15:00 PM	0	0	0	0	0	0	0	0	0	8	0	0	8	0	0	0	0	0	0	0	123	0	123	0	0	0	0	0	0
<b>Grand Total</b>	<b>0</b>	<b>0</b>	<b>0</b>	<b>0</b>	<b>0</b>	<b>0</b>	<b>0</b>	<b>0</b>	<b>0</b>	<b>41</b>	<b>0</b>	<b>0</b>	<b>41</b>	<b>0</b>	<b>1</b>	<b>0</b>	<b>0</b>	<b>0</b>	<b>0</b>	<b>0</b>	<b>434</b>	<b>0</b>	<b>434</b>	<b>0</b>	<b>0</b>	<b>0</b>	<b>0</b>	<b>0</b>	<b>0</b>
% Approach	#####	#####	#####	0.0%	0.0%	0.0%	0.0%	0.0%	0.0%	14.2%	0.0%	0.0%	0.0%	0.0%	0.0%	0.0%	0.0%	0.0%	45.1%	41.7%	0.0%	0.0%	0.0%	0.0%	0.0%	0.0%	0.0%	0.0%	
% Total	0.0%	0.0%	0.0%	0.0%	0.0%	0.0%	0.0%	0.0%	0.0%	8.6%	0.0%	0.0%	8.6%	0.0%	0.0%	0.0%	0.0%	0.0%	0.0%	91.4%	0.0%	0.0%	91.4%	0.0%	0.0%	0.0%	0.0%	0.0%	
PHF	0.000	0.000	0.000	0.000	0.000	0.000	0.000	0.000	0.000	0.683	0.000	0.000	0.683	0.000	0.000	0.000	0.000	0.000	0.000	0.882	0.000	0.000	0.882	0.000	0.000	0.000	0.000	0.000	
Lights	0	0	0	0	0	0	0	0	0	37	0	0	37	0	0	0	0	0	0	0	424	0	424	0	0	0	0	0	0
% Lights	0.0%	0.0%	0.0%	0.0%	0.0%	0.0%	0.0%	0.0%	0.0%	90.2%	0.0%	0.0%	90.2%	0.0%	0.0%	0.0%	0.0%	0.0%	0.0%	97.7%	0.0%	0.0%	97.7%	0.0%	0.0%	0.0%	0.0%	0.0%	
Trucks	0	0	0	0	0	0	0	0	0	4	0	0	4	0	0	0	0	0	0	0	0	0	0	0	0	0	0	0	0
% Trucks	0.0%	0.0%	0.0%	0.0%	0.0%	0.0%	0.0%	0.0%	0.0%	0.0%	0.0%	0.0%	0.0%	0.0%	0.0%	0.0%	0.0%	0.0%	0.0%	0.0%	0.0%	0.0%	0.0%	0.0%	0.0%	0.0%	0.0%	0.0%	
Buses	0	0	0	0	0	0	0	0	0	4	0	0	4	0	0	0	0	0	0	0	10	0	10	0	0	0	0	0	0
% Buses	0.0%	0.0%	0.0%	0.0%	0.0%	0.0%	0.0%	0.0%	0.0%	9.8%	0.0%	0.0%	0.0%	0.0%	0.0%	0.0%	0.0%	0.0%	0.0%	2.3%	0.0%	0.0%	0.0%	0.0%	0.0%	0.0%	0.0%	2.9%	
Pedestrians	0	0	0	0	0	0	0	0	0	0	0	0	0	0	1	0	0	0	0	0	0	0	0	0	0	0	0	0	0
% Pedestrians	0.0%	0.0%	0.0%	0.0%	0.0%	0.0%	0.0%	0.0%	0.0%	0.0%	0.0%	0.0%	0.0%	0.0%	100.0%	0.0%	0.0%	0.0%	0.0%	0.0%	0.0%	0.0%	0.0%	0.0%	0.0%	0.0%	0.0%	0.0%	
Bicycles on Crosswalk	0	0	0	0	0	0	0	0	0	0	0	0	0	0	0	0	0	0	0	0	0	0	0	0	0	0	0	0	0
% Bicycles on Crosswalk	0.0%	0.0%	0.0%	0.0%	0.0%	0.0%	0.0%	0.0%	0.0%	0.0%	0.0%	0.0%	0.0%	0.0%	0.0%	0.0%	0.0%	0.0%	0.0%	0.0%	0.0%	0.0%	0.0%	0.0%	0.0%	0.0%	0.0%	0.0%	

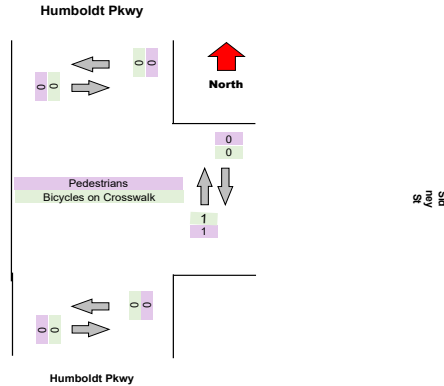
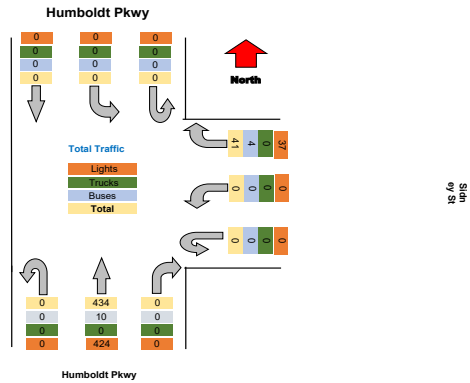



Intersection: Elm St Pine St  
 Location: Kennett Square, PA  
 Site: 01  
 Survey Date: Wednesday, 04-28-2021  
 GPS: 42.948550, -72.790034



Project	Labella
Project Code	Labella
Site Name	N
Legs and Movements	All Processed Legs & Movements
Bin Size	15 minutes
Survey Date	2021-10-27, Wednesday
Location	N
Latitude and Longitude	42.916336, -78.843106

	Start	End	PHF
Forced Peak AM	2021/10/27 07:30:00	2021/10/27 08:30:00	0.883
Forced Peak PM	2021/10/27 16:30:00	2021/10/27 17:30:00	0.914
AM Peak	2021/10/27 07:30:00	2021/10/27 08:30:00	0.883
PM Peak	2021/10/27 16:30:00	2021/10/27 17:30:00	0.914

Turning Movement Data

Leg Direction	Humboldt Pkwy Southbound						Sidney St Westbound						Humboldt Pkwy Northbound						Total									
	Thru	Left	U-Turn	App	Total	Peds	CW	Peds	CCW	Right	Left	U-Turn	App	Total	Peds	CW	Peds	CCW		Right	Thru	U-Turn	App	Total	Peds	CW	Peds	CCW
Start Time																												
6:30:00 AM	0	0	0	0	0	0	7	0	0	7	0	0	0	62	0	62	0	0	0	62	0	62	0	0	0	0	0	69
6:45:00 AM	0	0	0	0	0	0	9	0	0	9	0	0	0	65	0	65	0	0	0	65	0	65	0	0	0	0	0	74
<b>Hourly Total</b>	<b>0</b>	<b>0</b>	<b>0</b>	<b>0</b>	<b>0</b>	<b>0</b>	<b>16</b>	<b>0</b>	<b>0</b>	<b>16</b>	<b>0</b>	<b>0</b>	<b>0</b>	<b>127</b>	<b>0</b>	<b>127</b>	<b>0</b>	<b>0</b>	<b>0</b>	<b>127</b>	<b>0</b>	<b>127</b>	<b>0</b>	<b>0</b>	<b>0</b>	<b>0</b>	<b>0</b>	<b>143</b>
7:00:00 AM	0	0	0	0	0	0	8	0	0	8	0	1	0	68	0	69	0	0	0	69	0	69	0	0	0	0	0	77
7:15:00 AM	0	0	0	0	0	0	14	0	0	14	0	0	0	77	0	77	0	0	0	77	0	77	0	0	0	0	0	91
7:30:00 AM	0	0	0	0	0	0	10	0	0	10	1	0	0	104	0	105	0	0	0	104	0	105	0	0	0	0	0	115
7:45:00 AM	0	0	0	0	0	0	13	0	0	13	1	0	0	101	0	102	0	0	0	101	0	102	0	0	0	0	0	115
<b>Hourly Total</b>	<b>0</b>	<b>0</b>	<b>0</b>	<b>0</b>	<b>0</b>	<b>0</b>	<b>45</b>	<b>0</b>	<b>0</b>	<b>45</b>	<b>2</b>	<b>1</b>	<b>0</b>	<b>350</b>	<b>0</b>	<b>353</b>	<b>0</b>	<b>0</b>	<b>0</b>	<b>350</b>	<b>0</b>	<b>353</b>	<b>0</b>	<b>0</b>	<b>0</b>	<b>0</b>	<b>0</b>	<b>398</b>
8:00:00 AM	0	0	0	0	0	0	10	0	0	10	0	0	0	112	0	112	0	0	0	112	0	112	0	0	0	0	0	122
8:15:00 AM	0	0	0	0	0	0	3	0	0	3	1	1	0	74	0	76	0	0	0	74	0	76	0	0	0	0	0	79
<b>Hourly Total</b>	<b>0</b>	<b>0</b>	<b>0</b>	<b>0</b>	<b>0</b>	<b>0</b>	<b>13</b>	<b>0</b>	<b>0</b>	<b>13</b>	<b>1</b>	<b>1</b>	<b>0</b>	<b>186</b>	<b>0</b>	<b>188</b>	<b>0</b>	<b>0</b>	<b>0</b>	<b>186</b>	<b>0</b>	<b>188</b>	<b>0</b>	<b>0</b>	<b>0</b>	<b>0</b>	<b>0</b>	<b>201</b>
4:00:00 PM	0	0	0	0	0	0	10	1	0	11	0	0	0	138	0	138	0	0	0	138	0	138	0	0	0	0	0	149
4:15:00 PM	0	0	0	0	0	0	8	0	0	8	1	0	0	149	0	149	0	0	0	149	0	149	0	0	0	0	0	157
4:30:00 PM	0	0	0	0	0	0	15	0	0	15	0	1	0	139	0	139	0	0	0	139	0	139	0	0	0	0	0	154
4:45:00 PM	0	0	0	0	0	0	13	0	0	13	0	0	0	123	0	123	0	0	0	123	0	123	0	0	0	0	0	136
<b>Hourly Total</b>	<b>0</b>	<b>0</b>	<b>0</b>	<b>0</b>	<b>0</b>	<b>0</b>	<b>46</b>	<b>1</b>	<b>0</b>	<b>47</b>	<b>1</b>	<b>1</b>	<b>0</b>	<b>549</b>	<b>0</b>	<b>549</b>	<b>0</b>	<b>0</b>	<b>0</b>	<b>549</b>	<b>0</b>	<b>549</b>	<b>0</b>	<b>0</b>	<b>0</b>	<b>0</b>	<b>0</b>	<b>596</b>
5:00:00 PM	0	0	0	0	0	0	6	0	0	6	0	0	0	123	0	123	0	0	0	123	0	123	0	0	0	0	0	129
5:15:00 PM	0	0	0	0	0	0	7	0	0	7	0	1	0	137	0	137	0	0	0	137	0	137	0	0	0	0	0	144
5:30:00 PM	0	0	0	0	0	0	15	0	0	15	0	2	0	124	0	124	0	0	0	124	0	124	0	0	0	0	0	139
5:45:00 PM	0	0	0	0	0	0	4	0	0	4	0	0	0	99	0	99	0	0	0	99	0	99	0	0	0	0	0	103
<b>Hourly Total</b>	<b>0</b>	<b>0</b>	<b>0</b>	<b>0</b>	<b>0</b>	<b>0</b>	<b>32</b>	<b>0</b>	<b>0</b>	<b>32</b>	<b>0</b>	<b>3</b>	<b>0</b>	<b>483</b>	<b>0</b>	<b>483</b>	<b>0</b>	<b>0</b>	<b>0</b>	<b>483</b>	<b>0</b>	<b>483</b>	<b>0</b>	<b>0</b>	<b>0</b>	<b>0</b>	<b>0</b>	<b>515</b>
<b>Grand Total</b>	<b>0</b>	<b>0</b>	<b>0</b>	<b>0</b>	<b>0</b>	<b>0</b>	<b>152</b>	<b>1</b>	<b>0</b>	<b>153</b>	<b>4</b>	<b>6</b>	<b>0</b>	<b>1695</b>	<b>0</b>	<b>1700</b>	<b>0</b>	<b>0</b>	<b>0</b>	<b>1695</b>	<b>0</b>	<b>1700</b>	<b>0</b>	<b>0</b>	<b>0</b>	<b>0</b>	<b>0</b>	<b>1853</b>
% Approach	0.0%	0.0%	0.0%	0.0%	0.0%	0.0%	99.3%	0.7%	0.0%	0.0%	0.0%	0.0%	0.0%	99.7%	0.0%	0.0%	0.0%	0.0%	0.0%	99.7%	0.0%	0.0%	0.0%	0.0%	0.0%	0.0%	0.0%	0.0%
% Total	0.0%	0.0%	0.0%	0.0%	0.0%	0.0%	8.2%	0.1%	0.0%	8.3%	0.0%	0.0%	0.0%	91.5%	0.0%	91.7%	0.0%	0.0%	0.0%	91.5%	0.0%	91.7%	0.0%	0.0%	0.0%	0.0%	0.0%	0.0%
Lights	0	0	0	0	0	0	137	1	0	138	0	0	0	1631	0	1631	0	0	0	1631	0	1631	0	0	0	0	0	1769
% Lights	0.0%	0.0%	0.0%	0.0%	0.0%	0.0%	90.1%	100.0%	0.0%	90.2%	0.0%	0.0%	0.0%	96.2%	0.0%	95.9%	0.0%	0.0%	0.0%	96.2%	0.0%	95.9%	0.0%	0.0%	0.0%	0.0%	0.0%	95.5%
Trucks	0	0	0	0	0	0	0	0	0	0	0	0	0	0	0	0	0	0	0	0	0	0	0	0	0	0	0	0
% Trucks	0.0%	0.0%	0.0%	0.0%	0.0%	0.0%	0.0%	0.0%	0.0%	0.0%	0.0%	0.0%	0.0%	0.0%	0.0%	0.0%	0.0%	0.0%	0.0%	0.0%	0.0%	0.0%	0.0%	0.0%	0.0%	0.0%	0.0%	0.0%
Buses	0	0	0	0	0	0	15	0	0	15	0	0	0	64	0	64	0	0	0	64	0	64	0	0	0	0	0	79
% Buses	0.0%	0.0%	0.0%	0.0%	0.0%	0.0%	0.0%	0.0%	0.0%	0.0%	0.0%	0.0%	0.0%	3.8%	0.0%	0.0%	0.0%	0.0%	0.0%	3.8%	0.0%	0.0%	0.0%	0.0%	0.0%	0.0%	0.0%	4.3%
Pedestrians	0	0	0	0	0	0	0	0	0	0	4	6	0	0	0	0	0	0	0	0	0	0	0	0	0	0	0	0
% Pedestrians	0.0%	0.0%	0.0%	0.0%	0.0%	0.0%	0.0%	0.0%	0.0%	0.0%	100.0%	100.0%	0.0%	0.0%	0.0%	0.0%	0.0%	0.0%	0.0%	0.0%	0.0%	0.0%	0.0%	0.0%	0.0%	0.0%	0.0%	0.0%
Bicycles on Crosswalk	0	0	0	0	0	0	0	0	0	0	0	0	0	0	0	0	0	0	0	0	0	0	0	0	0	0	0	0
% Bicycles on Crosswalk	0.0%	0.0%	0.0%	0.0%	0.0%	0.0%	0.0%	0.0%	0.0%	0.0%	0.0%	0.0%	0.0%	0.0%	0.0%	0.0%	0.0%	0.0%	0.0%	0.0%	0.0%	0.0%	0.0%	0.0%	0.0%	0.0%	0.0%	0.0%

Turning Movement Data Plot

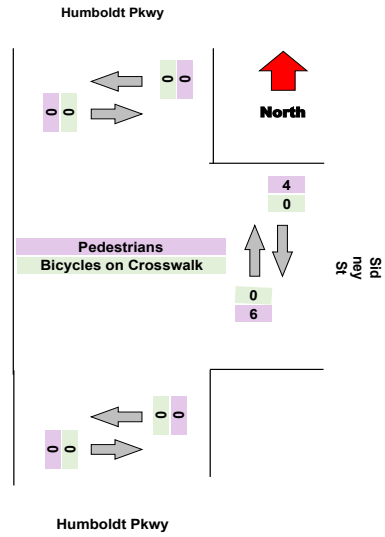
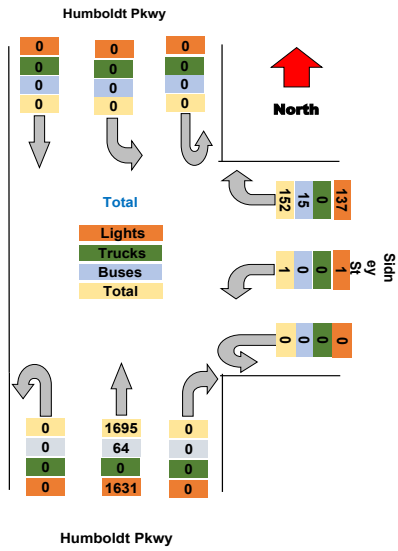

Turning Movement Peak Hour Data (AM)  
 7:30:00 AM

Leg	Humboldt Pkwy						Sidney St						Humboldt Pkwy						Total										
	Southbound						Westbound						Northbound																
Direction	Thru	Left	U-Turn	App	Total	Peds	CW	Peds	CCW	Right	Left	U-Turn	App	Total	Peds	CW	Peds	CCW	Right	Thru	U-Turn	App	Total	Peds	CW	Peds	CCW		
7:30:00 AM	0	0	0	0	0	0	0	0	0	10	0	0	10	1	0	0	0	0	0	0	104	0	105	0	0	0	0	0	115
7:45:00 AM	0	0	0	0	0	0	0	0	0	13	0	0	13	1	0	0	0	0	0	101	0	102	0	0	0	0	0	115	
8:00:00 AM	0	0	0	0	0	0	0	0	0	10	0	0	10	0	0	0	0	0	0	112	0	112	0	0	0	0	0	122	
8:15:00 AM	0	0	0	0	0	0	0	0	0	3	0	0	3	1	1	0	0	0	0	74	0	76	0	0	0	0	0	79	
<b>Grand Total</b>	<b>0</b>	<b>0</b>	<b>0</b>	<b>0</b>	<b>0</b>	<b>0</b>	<b>0</b>	<b>0</b>	<b>0</b>	<b>36</b>	<b>0</b>	<b>0</b>	<b>36</b>	<b>3</b>	<b>1</b>	<b>0</b>	<b>0</b>	<b>0</b>	<b>0</b>	<b>391</b>	<b>0</b>	<b>395</b>	<b>0</b>	<b>0</b>	<b>0</b>	<b>0</b>	<b>0</b>	<b>431</b>	
% Approach	#####	#####	#####	0.0%	0.0%	0.0%	0.0%	0.0%	0.0%	14.2%	0.0%	0.0%	0.0%	0.0%	0.0%	0.0%	0.0%	0.0%	45.1%	41.7%	0.0%	0.0%	0.0%	0.0%	0.0%	0.0%	0.0%		
% Total	0.0%	0.0%	0.0%	0.0%	0.0%	0.0%	0.0%	0.0%	0.0%	8.4%	0.0%	0.0%	8.4%	0.0%	0.0%	0.0%	0.0%	0.0%	0.0%	90.7%	0.0%	91.6%	0.0%	0.0%	0.0%	0.0%	0.0%		
PHF	0.000	0.000	0.000	0.000	0.000	0.000	0.000	0.000	0.000	0.692	0.000	0.000	0.692	0.000	0.000	0.000	0.000	0.000	0.000	0.873	0.000	0.882	0.000	0.000	0.000	0.000	0.000	0.883	
Lights	0	0	0	0	0	0	0	0	0	36	0	0	36	0	0	0	0	0	0	377	0	377	0	0	0	0	0	413	
% Lights	0.0%	0.0%	0.0%	0.0%	0.0%	0.0%	0.0%	0.0%	0.0%	100.0%	0.0%	0.0%	100.0%	0.0%	0.0%	0.0%	0.0%	0.0%	0.0%	96.4%	0.0%	95.4%	0.0%	0.0%	0.0%	0.0%	0.0%	95.8%	
Trucks	0	0	0	0	0	0	0	0	0	0	0	0	0	0	0	0	0	0	0	0	0	0	0	0	0	0	0	0	
% Trucks	0.0%	0.0%	0.0%	0.0%	0.0%	0.0%	0.0%	0.0%	0.0%	0.0%	0.0%	0.0%	0.0%	0.0%	0.0%	0.0%	0.0%	0.0%	0.0%	0.0%	0.0%	0.0%	0.0%	0.0%	0.0%	0.0%	0.0%	0.0%	
Buses	0	0	0	0	0	0	0	0	0	0	0	0	0	0	0	0	0	0	0	14	0	14	0	0	0	0	0	14	
% Buses	0.0%	0.0%	0.0%	0.0%	0.0%	0.0%	0.0%	0.0%	0.0%	0.0%	0.0%	0.0%	0.0%	0.0%	0.0%	0.0%	0.0%	0.0%	0.0%	3.6%	0.0%	0.0%	0.0%	0.0%	0.0%	0.0%	0.0%	3.2%	
Pedestrians	0	0	0	0	0	0	0	0	0	0	0	0	0	3	1	0	0	0	0	0	0	0	0	0	0	0	0	0	
% Pedestrians	0.0%	0.0%	0.0%	0.0%	0.0%	0.0%	0.0%	0.0%	0.0%	0.0%	0.0%	0.0%	0.0%	100.0%	100.0%	0.0%	0.0%	0.0%	0.0%	0.0%	0.0%	0.0%	0.0%	0.0%	0.0%	0.0%	0.0%	0.0%	
Bicycles on Crosswalk	0	0	0	0	0	0	0	0	0	0	0	0	0	0	0	0	0	0	0	0	0	0	0	0	0	0	0	0	
% Bicycles on Crosswalk	0.0%	0.0%	0.0%	0.0%	0.0%	0.0%	0.0%	0.0%	0.0%	0.0%	0.0%	0.0%	0.0%	0.0%	0.0%	0.0%	0.0%	0.0%	0.0%	0.0%	0.0%	0.0%	0.0%	0.0%	0.0%	0.0%	0.0%	0.0%	

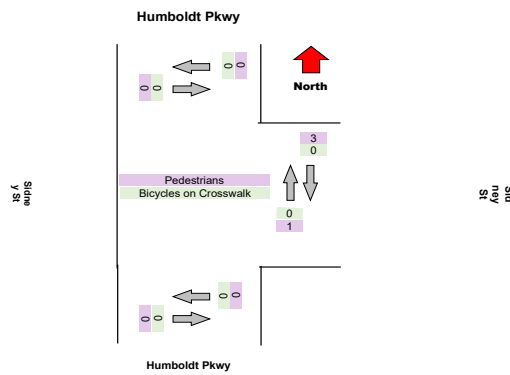
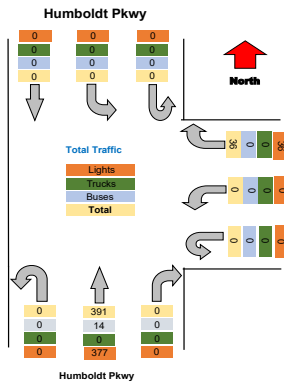

Turning Movement Peak Hour Data (PM)  
 4:30:00 PM

Leg	Humboldt Pkwy						Sidney St						Humboldt Pkwy						Total						
	Southbound						Westbound						Northbound												
Direction	Thru	Left	U-Turn	App	Total		Right	Left	U-Turn	App	Total	Peds	CW	Peds	CCW	Right	Thru	U-Turn	App	Total	Peds	CW	Peds	CCW	
4:30:00 PM	0	0	0	0	0	0	15	0	0	15	0	1	0	139	0	139	0	0	0	139	0	0	0	0	0
4:45:00 PM	0	0	0	0	0	0	13	0	0	13	0	0	0	123	0	123	0	0	0	123	0	0	0	0	0
5:00:00 PM	0	0	0	0	0	0	6	0	0	6	0	0	0	123	0	123	0	0	0	123	0	0	0	0	0
5:15:00 PM	0	0	0	0	0	0	7	0	0	7	0	1	0	137	0	137	0	0	0	137	0	0	0	0	0
<b>Grand Total</b>	<b>0</b>	<b>0</b>	<b>0</b>	<b>0</b>	<b>0</b>	<b>0</b>	<b>41</b>	<b>0</b>	<b>0</b>	<b>41</b>	<b>0</b>	<b>2</b>	<b>0</b>	<b>522</b>	<b>0</b>	<b>522</b>	<b>0</b>	<b>0</b>	<b>0</b>	<b>522</b>	<b>0</b>	<b>0</b>	<b>0</b>	<b>0</b>	
% Approach	#####	#####	#####	0.0%	0.0%	0.0%	14.2%	0.0%	0.0%	0.0%	0.0%	0.0%	45.1%	41.7%	0.0%	0.0%	0.0%	0.0%	0.0%	0.0%	0.0%	0.0%	0.0%	0.0%	
% Total	0.0%	0.0%	0.0%	0.0%	0.0%	0.0%	7.3%	0.0%	0.0%	0.0%	7.3%	0.0%	0.0%	0.0%	0.0%	0.0%	92.7%	0.0%	0.0%	92.7%	0.0%	0.0%	0.0%	0.0%	
PHF	0.000	0.000	0.000	0.000	0.000	0.000	0.683	0.000	0.000	0.000	0.683	0.000	0.000	0.000	0.000	0.000	0.939	0.000	0.000	0.939	0.000	0.000	0.000	0.000	
Lights	0	0	0	0	0	0	36	0	0	36	0	0	0	508	0	508	0	0	0	508	0	0	0	0	
% Lights	0.0%	0.0%	0.0%	0.0%	0.0%	0.0%	87.8%	0.0%	0.0%	87.8%	0.0%	0.0%	0.0%	97.3%	0.0%	0.0%	97.3%	0.0%	0.0%	97.3%	0.0%	0.0%	0.0%	0.0%	
Trucks	0	0	0	0	0	0	0	0	0	0	0	0	0	0	0	0	0	0	0	0	0	0	0	0	
% Trucks	0.0%	0.0%	0.0%	0.0%	0.0%	0.0%	0.0%	0.0%	0.0%	0.0%	0.0%	0.0%	0.0%	0.0%	0.0%	0.0%	0.0%	0.0%	0.0%	0.0%	0.0%	0.0%	0.0%	0.0%	
Buses	0	0	0	0	0	0	5	0	0	5	0	0	0	14	0	14	0	0	0	14	0	0	0	0	
% Buses	0.0%	0.0%	0.0%	0.0%	0.0%	0.0%	12.2%	0.0%	0.0%	12.2%	0.0%	0.0%	0.0%	2.7%	0.0%	0.0%	2.7%	0.0%	0.0%	2.7%	0.0%	0.0%	0.0%	0.0%	
Pedestrians	0	0	0	0	0	0	0	0	0	0	0	2	0	0	0	0	0	0	0	0	0	0	0	0	
% Pedestrians	0.0%	0.0%	0.0%	0.0%	0.0%	0.0%	0.0%	0.0%	0.0%	0.0%	0.0%	100.0%	0.0%	0.0%	0.0%	0.0%	0.0%	0.0%	0.0%	0.0%	0.0%	0.0%	0.0%	0.0%	
Bicycles on Crosswalk	0	0	0	0	0	0	0	0	0	0	0	0	0	0	0	0	0	0	0	0	0	0	0	0	
% Bicycles on Crosswalk	0.0%	0.0%	0.0%	0.0%	0.0%	0.0%	0.0%	0.0%	0.0%	0.0%	0.0%	0.0%	0.0%	0.0%	0.0%	0.0%	0.0%	0.0%	0.0%	0.0%	0.0%	0.0%	0.0%	0.0%	

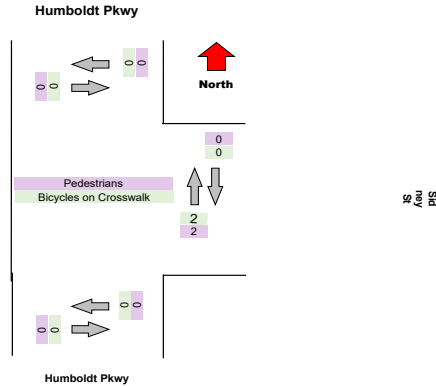
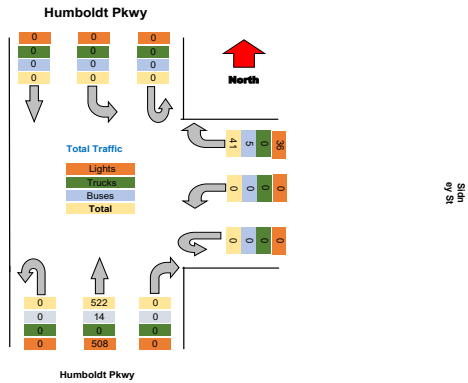



Turning Movement Data Plot

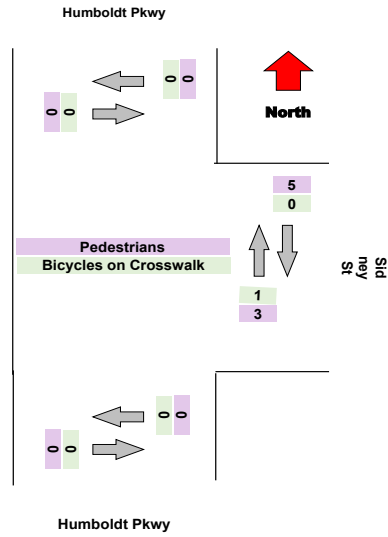
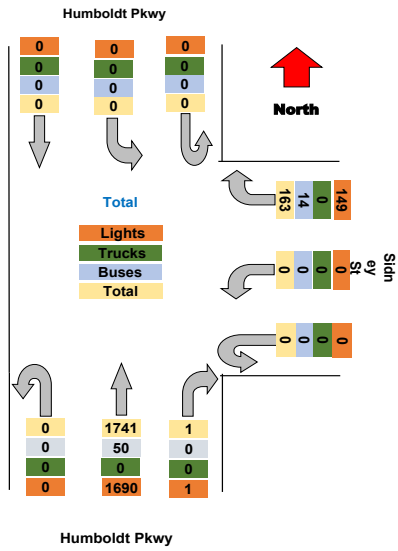

Turning Movement Peak Hour Data (AM)

7:30:00 AM

Leg	Humboldt Pkwy						Sidney St						Humboldt Pkwy						Total									
	Southbound						Westbound						Northbound															
Direction	Thru	Left	U-Turn	App	Total	Peds	CW	Peds	CCW	Right	Left	U-Turn	App	Total	Peds	CW	Peds	CCW	Right	Thru	U-Turn	App	Total	Peds	CW	Peds	CCW	
7:30:00 AM	0	0	0	0	0	0	0	0	0	9	0	0	9	1	0	0	0	0	0	0	102	0	103	0	0	0	0	0
7:45:00 AM	0	0	0	0	0	0	0	0	0	12	0	0	12	1	0	0	0	0	0	0	128	0	129	0	0	0	0	0
8:00:00 AM	0	0	0	0	0	0	0	0	0	8	0	0	8	1	0	0	0	0	0	0	113	0	114	0	0	0	0	0
8:15:00 AM	0	0	0	0	0	0	0	0	0	6	0	0	6	0	1	0	0	0	0	0	86	0	87	0	0	0	0	0
<b>Grand Total</b>	<b>0</b>	<b>0</b>	<b>0</b>	<b>0</b>	<b>0</b>	<b>0</b>	<b>0</b>	<b>0</b>	<b>0</b>	<b>35</b>	<b>0</b>	<b>0</b>	<b>35</b>	<b>3</b>	<b>1</b>	<b>0</b>	<b>0</b>	<b>0</b>	<b>0</b>	<b>0</b>	<b>429</b>	<b>0</b>	<b>433</b>	<b>0</b>	<b>0</b>	<b>0</b>	<b>0</b>	<b>0</b>
% Approach	#####	#####	#####	0.0%	0.0%	0.0%	0.0%	0.0%	0.0%	14.2%	0.0%	0.0%	0.0%	0.0%	0.0%	0.0%	0.0%	0.0%	0.0%	45.1%	41.7%	0.0%	0.0%	0.0%	0.0%	0.0%	0.0%	0.0%
% Total	0.0%	0.0%	0.0%	0.0%	0.0%	0.0%	0.0%	0.0%	0.0%	7.5%	0.0%	0.0%	7.5%	0.0%	0.0%	0.0%	0.0%	0.0%	0.0%	0.0%	91.7%	0.0%	92.5%	0.0%	0.0%	0.0%	0.0%	0.0%
PHF	0.000	0.000	0.000	0.000	0.000	0.000	0.000	0.000	0.000	0.729	0.000	0.000	0.729	0.000	0.000	0.000	0.000	0.000	0.000	0.000	0.838	0.000	0.839	0.000	0.000	0.000	0.000	0.830
Lights	0	0	0	0	0	0	0	0	0	35	0	0	35	0	0	0	0	0	0	0	416	0	416	0	0	0	0	451
% Lights	0.0%	0.0%	0.0%	0.0%	0.0%	0.0%	0.0%	0.0%	0.0%	100.0%	0.0%	0.0%	100.0%	0.0%	0.0%	0.0%	0.0%	0.0%	0.0%	0.0%	97.0%	0.0%	96.1%	0.0%	0.0%	0.0%	0.0%	96.4%
Trucks	0	0	0	0	0	0	0	0	0	0	0	0	0	0	0	0	0	0	0	0	0	0	0	0	0	0	0	0
% Trucks	0.0%	0.0%	0.0%	0.0%	0.0%	0.0%	0.0%	0.0%	0.0%	0.0%	0.0%	0.0%	0.0%	0.0%	0.0%	0.0%	0.0%	0.0%	0.0%	0.0%	0.0%	0.0%	0.0%	0.0%	0.0%	0.0%	0.0%	0.0%
Buses	0	0	0	0	0	0	0	0	0	0	0	0	0	0	0	0	0	0	0	0	13	0	13	0	0	0	0	13
% Buses	0.0%	0.0%	0.0%	0.0%	0.0%	0.0%	0.0%	0.0%	0.0%	0.0%	0.0%	0.0%	0.0%	0.0%	0.0%	0.0%	0.0%	0.0%	0.0%	0.0%	3.0%	0.0%	0.0%	0.0%	0.0%	0.0%	0.0%	2.8%
Pedestrians	0	0	0	0	0	0	0	0	0	0	0	0	0	3	1	0	0	0	0	0	0	0	0	0	0	0	0	0
% Pedestrians	0.0%	0.0%	0.0%	0.0%	0.0%	0.0%	0.0%	0.0%	0.0%	0.0%	0.0%	0.0%	0.0%	100.0%	100.0%	0.0%	0.0%	0.0%	0.0%	0.0%	0.0%	0.0%	0.0%	0.0%	0.0%	0.0%	0.0%	0.0%
Bicycles on Crosswalk	0	0	0	0	0	0	0	0	0	0	0	0	0	0	0	0	0	0	0	0	0	0	0	0	0	0	0	0
% Bicycles on Crosswalk	0.0%	0.0%	0.0%	0.0%	0.0%	0.0%	0.0%	0.0%	0.0%	0.0%	0.0%	0.0%	0.0%	0.0%	0.0%	0.0%	0.0%	0.0%	0.0%	0.0%	0.0%	0.0%	0.0%	0.0%	0.0%	0.0%	0.0%	0.0%

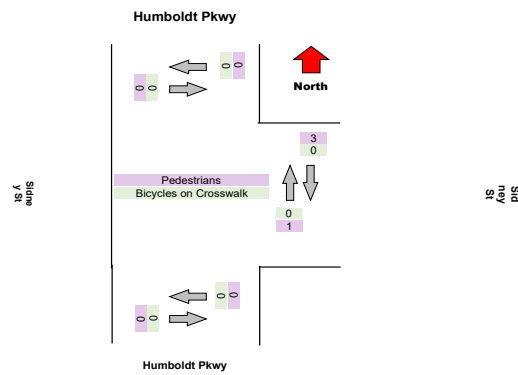
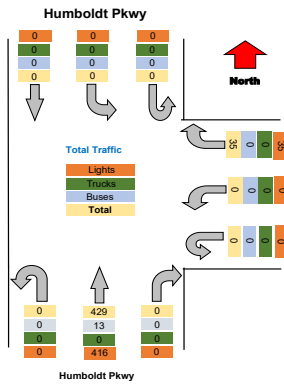

Turning Movement Peak Hour Data (PM)  
 4:30:00 PM

Leg	Humboldt Pkwy						Sidney St						Humboldt Pkwy						Total						
	Southbound						Westbound						Northbound												
Direction	Thru	Left	U-Turn	App	Total		Right	Left	U-Turn	App	Total	Peds	CW	Peds	CCW	Right	Thru	U-Turn	App	Total	Peds	CW	Peds	CCW	
4:30:00 PM	0	0	0	0	0	0	15	0	0	15	0	1	0	123	0	123	0	0	0	0	0	0	0	0	0
4:45:00 PM	0	0	0	0	0	0	10	0	0	10	0	0	0	120	0	120	0	0	0	0	0	0	0	0	0
5:00:00 PM	0	0	0	0	0	0	10	0	0	10	0	0	0	152	0	152	0	0	0	0	0	0	0	0	0
5:15:00 PM	0	0	0	0	0	0	7	0	0	7	1	1	0	122	0	122	0	0	0	0	0	0	0	0	0
<b>Grand Total</b>	<b>0</b>	<b>0</b>	<b>0</b>	<b>0</b>	<b>0</b>	<b>0</b>	<b>42</b>	<b>0</b>	<b>0</b>	<b>42</b>	<b>1</b>	<b>2</b>	<b>0</b>	<b>517</b>	<b>0</b>	<b>517</b>	<b>0</b>	<b>0</b>	<b>0</b>	<b>0</b>	<b>0</b>	<b>0</b>	<b>0</b>	<b>0</b>	<b>0</b>
% Approach	#####	#####	#####	0.0%	0.0%	0.0%	14.2%	0.0%	0.0%	0.0%	0.0%	0.0%	45.1%	41.7%	0.0%	0.0%	0.0%	0.0%	0.0%	0.0%	0.0%	0.0%	0.0%	0.0%	
% Total	0.0%	0.0%	0.0%	0.0%	0.0%	0.0%	7.5%	0.0%	0.0%	7.5%	0.0%	0.0%	0.0%	92.5%	0.0%	92.5%	0.0%	0.0%	0.0%	0.0%	0.0%	0.0%	0.0%	0.0%	
PHF	0.000	0.000	0.000	0.000	0.000	0.000	0.700	0.000	0.000	0.700	0.000	0.000	0.000	0.850	0.000	0.850	0.000	0.000	0.000	0.000	0.000	0.000	0.000	0.863	
Lights	0	0	0	0	0	0	38	0	0	38	0	0	0	512	0	512	0	0	0	0	0	0	0	0	0
% Lights	0.0%	0.0%	0.0%	0.0%	0.0%	0.0%	90.5%	0.0%	0.0%	90.5%	0.0%	0.0%	0.0%	99.0%	0.0%	99.0%	0.0%	0.0%	0.0%	0.0%	0.0%	0.0%	0.0%	98.4%	
Trucks	0	0	0	0	0	0	4	0	0	4	0	0	0	0	0	0	0	0	0	0	0	0	0	0	0
% Trucks	0.0%	0.0%	0.0%	0.0%	0.0%	0.0%	0.0%	0.0%	0.0%	0.0%	0.0%	0.0%	0.0%	0.0%	0.0%	0.0%	0.0%	0.0%	0.0%	0.0%	0.0%	0.0%	0.0%	0.0%	0.0%
Buses	0	0	0	0	0	0	4	0	0	4	0	0	0	5	0	5	0	0	0	0	0	0	0	0	0
% Buses	0.0%	0.0%	0.0%	0.0%	0.0%	0.0%	9.5%	0.0%	0.0%	9.5%	0.0%	0.0%	0.0%	1.0%	0.0%	1.0%	0.0%	0.0%	0.0%	0.0%	0.0%	0.0%	0.0%	1.6%	
Pedestrians	0	0	0	0	0	0	0	0	0	0	1	1	0	0	0	0	0	0	0	0	0	0	0	0	0
% Pedestrians	0.0%	0.0%	0.0%	0.0%	0.0%	0.0%	0.0%	0.0%	0.0%	0.0%	100.0%	50.0%	0.0%	0.0%	0.0%	0.0%	0.0%	0.0%	0.0%	0.0%	0.0%	0.0%	0.0%	0.0%	0.0%
Bicycles on Crosswalk	0	0	0	0	0	0	0	0	0	0	0	1	0	0	0	0	0	0	0	0	0	0	0	0	0
% Bicycles on Crosswalk	0.0%	0.0%	0.0%	0.0%	0.0%	0.0%	0.0%	0.0%	0.0%	0.0%	0.0%	50.0%	0.0%	0.0%	0.0%	0.0%	0.0%	0.0%	0.0%	0.0%	0.0%	0.0%	0.0%	0.0%	0.0%

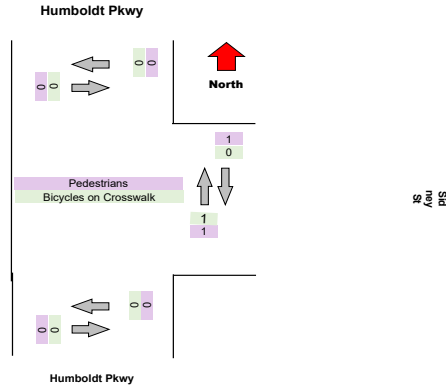
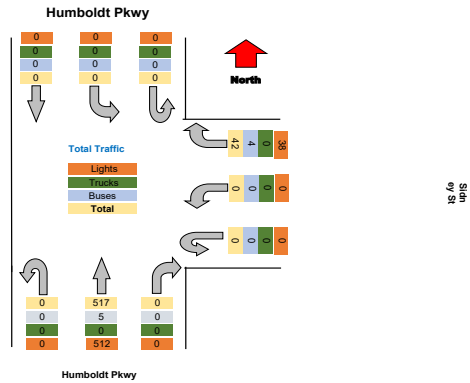





Turning Movement Data Plot

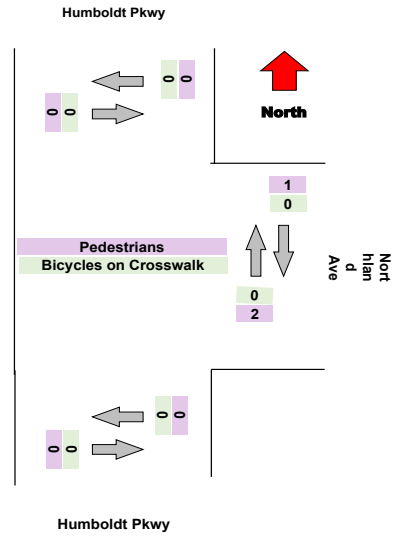
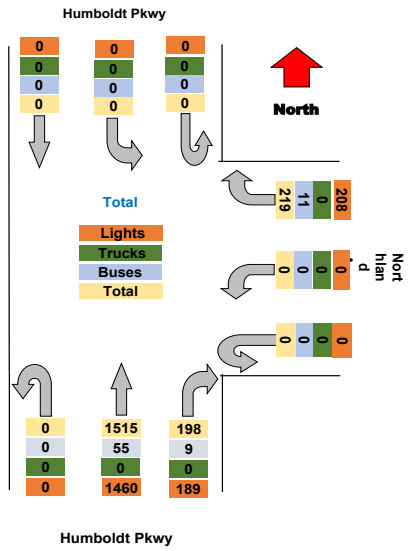

Turning Movement Peak Hour Data (AM)  
 7:30:00 AM

Leg Direction	Humboldt Pkwy Southbound						Northland Ave Westbound						Humboldt Pkwy Northbound						Total
	Thru	Left	U-Turn	App Total	Peds CW	Peds CCW	Right	Left	U-Turn	App Total	Peds CW	Peds CCW	Right	Thru	U-Turn	App Total	Peds CW	Peds CCW	
7:30:00 AM	0	0	0	0	0	0	10	0	0	10	1	0	10	106	0	117	0	0	127
7:45:00 AM	0	0	0	0	0	0	9	0	0	9	0	1	22	86	0	109	0	0	118
8:00:00 AM	0	0	0	0	0	0	11	0	0	11	0	0	13	97	0	110	0	0	121
8:15:00 AM	0	0	0	0	0	0	12	0	0	12	0	0	11	90	0	101	0	0	113
<b>Grand Total</b>	<b>0</b>	<b>0</b>	<b>0</b>	<b>0</b>	<b>0</b>	<b>0</b>	<b>42</b>	<b>0</b>	<b>0</b>	<b>42</b>	<b>1</b>	<b>1</b>	<b>56</b>	<b>379</b>	<b>0</b>	<b>437</b>	<b>0</b>	<b>0</b>	<b>479</b>
% Approach	#####	#####	#####	0.0%	0.0%	0.0%	14.2%	0.0%	0.0%	0.0%	0.0%	0.0%	45.1%	41.7%	0.0%	0.0%	0.0%	0.0%	
% Total	0.0%	0.0%	0.0%	0.0%	0.0%	0.0%	8.8%	0.0%	0.0%	8.8%	0.0%	0.0%	11.7%	79.1%	0.0%	91.2%	0.0%	0.0%	
PHF	0.000	0.000	0.000	0.000	0.000	0.000	0.875	0.000	0.000	0.875	0.000	0.000	0.636	0.894	0.000	0.934	0.000	0.000	0.943
Lights	0	0	0	0	0	0	39	0	0	39	0	0	53	369	0	422	0	0	461
% Lights	0.0%	0.0%	0.0%	0.0%	0.0%	0.0%	92.9%	0.0%	0.0%	92.9%	0.0%	0.0%	94.6%	97.4%	0.0%	96.6%	0.0%	0.0%	96.2%
Trucks	0	0	0	0	0	0	0	0	0	0	0	0	0	0	0	0	0	0	0
% Trucks	0.0%	0.0%	0.0%	0.0%	0.0%	0.0%	0.0%	0.0%	0.0%	0.0%	0.0%	0.0%	0.0%	0.0%	0.0%	0.0%	0.0%	0.0%	0.0%
Buses	0	0	0	0	0	0	3	0	0	3	0	0	3	10	0	13	0	0	16
% Buses	0.0%	0.0%	0.0%	0.0%	0.0%	0.0%	7.1%	0.0%	0.0%	0.0%	0.0%	0.0%	5.4%	2.6%	0.0%	0.0%	0.0%	0.0%	3.3%
Pedestrians	0	0	0	0	0	0	0	0	0	0	1	1	0	0	0	0	0	0	0
% Pedestrians	0.0%	0.0%	0.0%	0.0%	0.0%	0.0%	0.0%	0.0%	0.0%	0.0%	100.0%	100.0%	0.0%	0.0%	0.0%	0.0%	0.0%	0.0%	0.0%
Bicycles on Crosswalk	0	0	0	0	0	0	0	0	0	0	0	0	0	0	0	0	0	0	0
% Bicycles on Crosswalk	0.0%	0.0%	0.0%	0.0%	0.0%	0.0%	0.0%	0.0%	0.0%	0.0%	0.0%	0.0%	0.0%	0.0%	0.0%	0.0%	0.0%	0.0%	0.0%

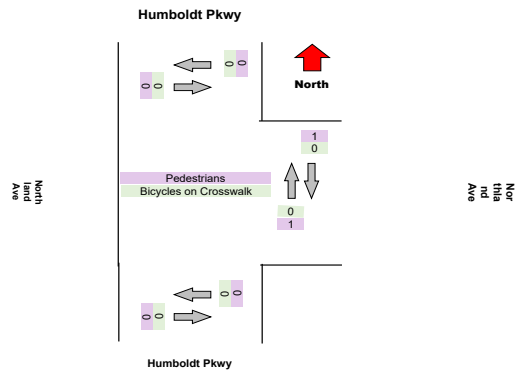
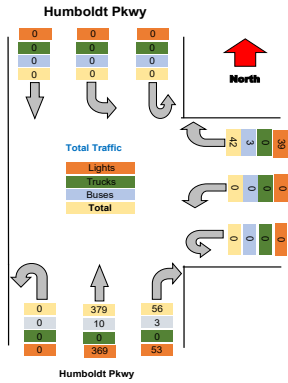

Turning Movement Peak Hour Data (PM)  
 4:30:00 PM

Leg Direction	Humboldt Pkwy						Northland Ave						Humboldt Pkwy						Total
	Southbound			Westbound			Northbound			Northbound									
Start Time	Thru	Left	U-Turn	App Total	Peds CW	Peds CCW	Right	Left	U-Turn	App Total	Peds CW	Peds CCW	Right	Thru	U-Turn	App Total	Peds CW	Peds CCW	
4:30:00 PM	0	0	0	0	0	0	17	0	0	17	0	0	14	106	0	120	0	0	137
4:45:00 PM	0	0	0	0	0	0	21	0	0	21	0	0	19	86	0	105	0	0	126
5:00:00 PM	0	0	0	0	0	0	19	0	0	19	0	0	12	108	0	120	0	0	139
5:15:00 PM	0	0	0	0	0	0	21	0	0	21	0	0	16	115	0	131	0	0	152
<b>Grand Total</b>	<b>0</b>	<b>0</b>	<b>0</b>	<b>0</b>	<b>0</b>	<b>0</b>	<b>78</b>	<b>0</b>	<b>0</b>	<b>78</b>	<b>0</b>	<b>0</b>	<b>61</b>	<b>415</b>	<b>0</b>	<b>476</b>	<b>0</b>	<b>0</b>	<b>554</b>
% Approach	#####	#####	#####	0.0%	0.0%	0.0%	14.2%	0.0%	0.0%	0.0%	0.0%	0.0%	45.1%	41.7%	0.0%	0.0%	0.0%	0.0%	
% Total	0.0%	0.0%	0.0%	0.0%	0.0%	0.0%	14.1%	0.0%	0.0%	14.1%	0.0%	0.0%	11.0%	74.9%	0.0%	85.9%	0.0%	0.0%	
PHF	0.000	0.000	0.000	0.000	0.000	0.000	0.929	0.000	0.000	0.929	0.000	0.000	0.803	0.902	0.000	0.908	0.000	0.000	0.911
Lights	0	0	0	0	0	0	76	0	0	76	0	0	59	403	0	462	0	0	538
% Lights	0.0%	0.0%	0.0%	0.0%	0.0%	0.0%	97.4%	0.0%	0.0%	97.4%	0.0%	0.0%	96.7%	97.1%	0.0%	97.1%	0.0%	0.0%	97.1%
Trucks	0	0	0	0	0	0	0	0	0	0	0	0	0	0	0	0	0	0	0
% Trucks	0.0%	0.0%	0.0%	0.0%	0.0%	0.0%	0.0%	0.0%	0.0%	0.0%	0.0%	0.0%	0.0%	0.0%	0.0%	0.0%	0.0%	0.0%	0.0%
Buses	0	0	0	0	0	0	2	0	0	2	0	0	2	12	0	14	0	0	16
% Buses	0.0%	0.0%	0.0%	0.0%	0.0%	0.0%	2.6%	0.0%	0.0%	2.6%	0.0%	0.0%	3.3%	2.9%	0.0%	3.0%	0.0%	0.0%	2.9%
Pedestrians	0	0	0	0	0	0	0	0	0	0	0	0	0	0	0	0	0	0	0
% Pedestrians	0.0%	0.0%	0.0%	0.0%	0.0%	0.0%	0.0%	0.0%	0.0%	0.0%	0.0%	0.0%	0.0%	0.0%	0.0%	0.0%	0.0%	0.0%	0.0%
Bicycles on Crosswalk	0	0	0	0	0	0	0	0	0	0	0	0	0	0	0	0	0	0	0
% Bicycles on Crosswalk	0.0%	0.0%	0.0%	0.0%	0.0%	0.0%	0.0%	0.0%	0.0%	0.0%	0.0%	0.0%	0.0%	0.0%	0.0%	0.0%	0.0%	0.0%	0.0%

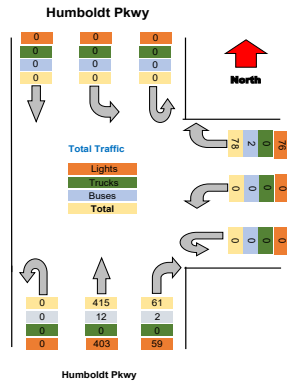

North  
land  
Ave

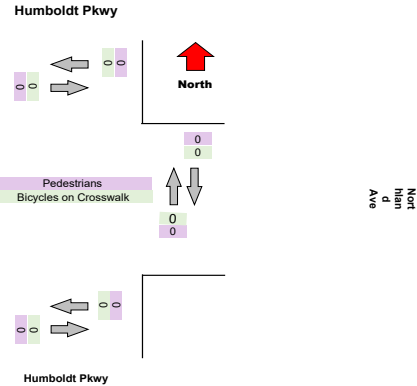

North  
land  
Ave



Turning Movement Data Plot

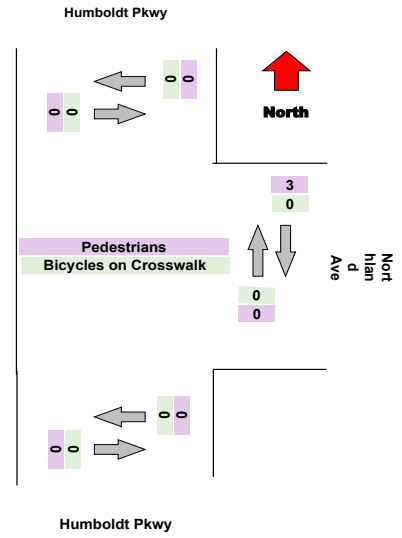
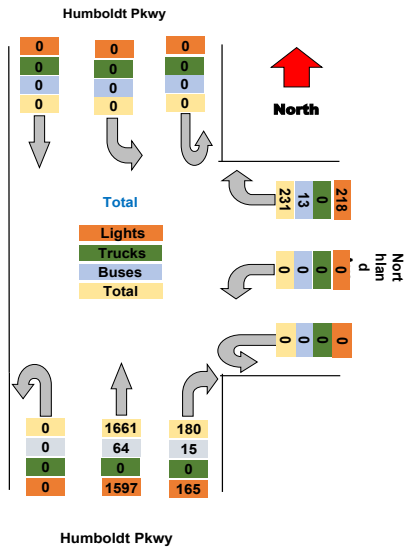

Turning Movement Peak Hour Data (AM)  
 7:30:00 AM

Leg Direction	Humboldt Pkwy Southbound						Northland Ave Westbound						Humboldt Pkwy Northbound						Total				
	Thru	Left	U-Turn	App	Total	Peds CW	Peds CCW	Right	Left	U-Turn	App	Total	Peds CW	Peds CCW	Right	Thru	U-Turn	App		Total	Peds CW	Peds CCW	
7:30:00 AM	0	0	0	0	0	0	0	15	0	0	15	3	0	0	13	103	0	119	0	0	0	0	134
7:45:00 AM	0	0	0	0	0	0	0	14	0	0	14	0	0	0	19	91	0	110	0	0	0	0	124
8:00:00 AM	0	0	0	0	0	0	0	14	0	0	14	0	0	0	14	103	0	117	0	0	0	0	131
8:15:00 AM	0	0	0	0	0	0	0	7	0	0	7	0	0	0	5	71	0	76	0	0	0	0	83
<b>Grand Total</b>	<b>0</b>	<b>0</b>	<b>0</b>	<b>0</b>	<b>0</b>	<b>0</b>	<b>0</b>	<b>50</b>	<b>0</b>	<b>0</b>	<b>50</b>	<b>3</b>	<b>0</b>	<b>0</b>	<b>51</b>	<b>368</b>	<b>0</b>	<b>422</b>	<b>0</b>	<b>0</b>	<b>0</b>	<b>0</b>	<b>472</b>
% Approach	#####	#####	#####	0.0%	0.0%	0.0%	0.0%	14.2%	0.0%	0.0%	10.6%	0.0%	0.0%	0.0%	45.1%	41.7%	0.0%	0.0%	0.0%	0.0%	0.0%	0.0%	0.0%
% Total	0.0%	0.0%	0.0%	0.0%	0.0%	0.0%	0.0%	10.6%	0.0%	0.0%	10.6%	0.0%	0.0%	0.0%	10.8%	78.0%	0.0%	89.4%	0.0%	0.0%	0.0%	0.0%	0.0%
PHF	0.000	0.000	0.000	0.000	0.000	0.000	0.000	0.833	0.000	0.000	0.833	0.000	0.000	0.000	0.671	0.893	0.000	0.887	0.000	0.000	0.000	0.000	0.881
Lights	0	0	0	0	0	0	0	47	0	0	47	0	0	0	48	357	0	405	0	0	0	0	452
% Lights	0.0%	0.0%	0.0%	0.0%	0.0%	0.0%	0.0%	94.0%	0.0%	0.0%	94.0%	0.0%	0.0%	0.0%	94.1%	97.0%	0.0%	96.0%	0.0%	0.0%	0.0%	0.0%	95.8%
Trucks	0	0	0	0	0	0	0	0	0	0	0	0	0	0	0	0	0	0	0	0	0	0	0
% Trucks	0.0%	0.0%	0.0%	0.0%	0.0%	0.0%	0.0%	0.0%	0.0%	0.0%	0.0%	0.0%	0.0%	0.0%	0.0%	0.0%	0.0%	0.0%	0.0%	0.0%	0.0%	0.0%	0.0%
Buses	0	0	0	0	0	0	0	3	0	0	3	0	0	0	3	11	0	14	0	0	0	0	17
% Buses	0.0%	0.0%	0.0%	0.0%	0.0%	0.0%	0.0%	6.0%	0.0%	0.0%	6.0%	0.0%	0.0%	0.0%	5.9%	3.0%	0.0%	3.3%	0.0%	0.0%	0.0%	0.0%	3.6%
Pedestrians	0	0	0	0	0	0	0	0	0	0	0	3	0	0	0	0	0	0	0	0	0	0	0
% Pedestrians	0.0%	0.0%	0.0%	0.0%	0.0%	0.0%	0.0%	0.0%	0.0%	0.0%	0.0%	100.0%	0.0%	0.0%	0.0%	0.0%	0.0%	0.0%	0.0%	0.0%	0.0%	0.0%	0.0%
Bicycles on Crosswalk	0	0	0	0	0	0	0	0	0	0	0	0	0	0	0	0	0	0	0	0	0	0	0
% Bicycles on Crosswalk	0.0%	0.0%	0.0%	0.0%	0.0%	0.0%	0.0%	0.0%	0.0%	0.0%	0.0%	0.0%	0.0%	0.0%	0.0%	0.0%	0.0%	0.0%	0.0%	0.0%	0.0%	0.0%	0.0%

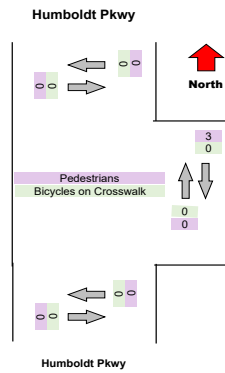
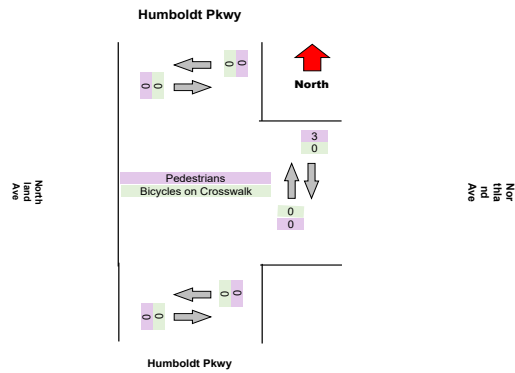
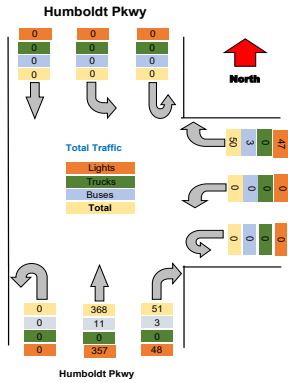

Turning Movement Peak Hour Data (PM)  
 4:30:00 PM

Leg Direction	Humboldt Pkwy						Northland Ave						Humboldt Pkwy						Total
	Thru	Left	U-Turn	App Total	Peds CW	Peds CCW	Right	Left	U-Turn	App Total	Peds CW	Peds CCW	Right	Thru	U-Turn	App Total	Peds CW	Peds CCW	
4:30:00 PM	0	0	0	0	0	0	15	0	0	15	0	0	15	145	0	160	0	0	175
4:45:00 PM	0	0	0	0	0	0	18	0	0	18	0	0	9	125	0	134	0	0	152
5:00:00 PM	0	0	0	0	0	0	18	0	0	18	0	0	13	116	0	129	0	0	147
5:15:00 PM	0	0	0	0	0	0	16	0	0	16	0	0	6	137	0	143	0	0	159
<b>Grand Total</b>	<b>0</b>	<b>0</b>	<b>0</b>	<b>0</b>	<b>0</b>	<b>0</b>	<b>67</b>	<b>0</b>	<b>0</b>	<b>67</b>	<b>0</b>	<b>0</b>	<b>43</b>	<b>523</b>	<b>0</b>	<b>566</b>	<b>0</b>	<b>0</b>	<b>633</b>
% Approach	#####	#####	#####	0.0%	0.0%	0.0%	14.2%	0.0%	0.0%	0.0%	0.0%	0.0%	45.1%	41.7%	0.0%	0.0%	0.0%	0.0%	
% Total	0.0%	0.0%	0.0%	0.0%	0.0%	0.0%	10.6%	0.0%	0.0%	10.6%	0.0%	0.0%	6.8%	82.6%	0.0%	89.4%	0.0%	0.0%	
PHF	0.000	0.000	0.000	0.000	0.000	0.000	0.931	0.000	0.000	0.931	0.000	0.000	0.717	0.902	0.000	0.884	0.000	0.000	0.904
Lights	0	0	0	0	0	0	67	0	0	67	0	0	38	509	0	547	0	0	614
% Lights	0.0%	0.0%	0.0%	0.0%	0.0%	0.0%	100.0%	0.0%	0.0%	100.0%	0.0%	0.0%	88.4%	97.3%	0.0%	96.6%	0.0%	0.0%	97.0%
Trucks	0	0	0	0	0	0	0	0	0	0	0	0	0	0	0	0	0	0	0
% Trucks	0.0%	0.0%	0.0%	0.0%	0.0%	0.0%	0.0%	0.0%	0.0%	0.0%	0.0%	0.0%	0.0%	0.0%	0.0%	0.0%	0.0%	0.0%	0.0%
Buses	0	0	0	0	0	0	0	0	0	0	0	0	5	14	0	19	0	0	19
% Buses	0.0%	0.0%	0.0%	0.0%	0.0%	0.0%	0.0%	0.0%	0.0%	0.0%	0.0%	0.0%	11.6%	2.7%	0.0%	0.0%	0.0%	0.0%	3.0%
Pedestrians	0	0	0	0	0	0	0	0	0	0	0	0	0	0	0	0	0	0	0
% Pedestrians	0.0%	0.0%	0.0%	0.0%	0.0%	0.0%	0.0%	0.0%	0.0%	0.0%	0.0%	0.0%	0.0%	0.0%	0.0%	0.0%	0.0%	0.0%	0.0%
Bicycles on Crosswalk	0	0	0	0	0	0	0	0	0	0	0	0	0	0	0	0	0	0	0
% Bicycles on Crosswalk	0.0%	0.0%	0.0%	0.0%	0.0%	0.0%	0.0%	0.0%	0.0%	0.0%	0.0%	0.0%	0.0%	0.0%	0.0%	0.0%	0.0%	0.0%	0.0%

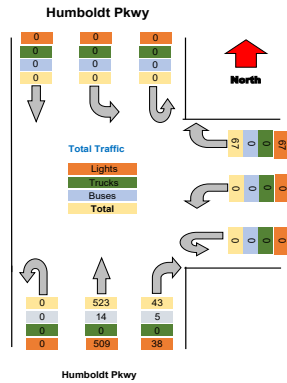

North  
 Ave

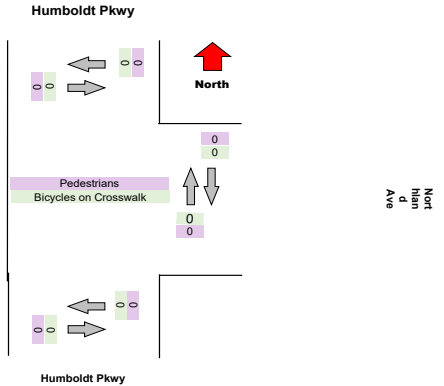

North  
 Ave



Intersection: Elm St Pine St  
 Location: Kennett Square, PA  
 Site: 01  
 Survey Date: Wednesday, 04-28-2021  
 GPS: 42.948550, -72.790034



Project	Labella
Project Code	Labella
Site Name	O
Legs and Movements	All Processed Legs & Movements
Bin Size	15 minutes
Survey Date	2021-10-28, Thursday
Location	O
Latitude and Longitude	42.919163, -78.843045

	Start	End	PHF
Forced Peak AM	2021/10/28 07:30:00	2021/10/28 08:30:00	0.852
Forced Peak PM	2021/10/28 16:30:00	2021/10/28 17:30:00	0.854
AM Peak	2021/10/28 07:30:00	2021/10/28 08:30:00	0.852
PM Peak	2021/10/28 16:30:00	2021/10/28 17:30:00	0.854

Turning Movement Data

Leg Direction	Humboldt Pkwy Southbound						Northland Ave Westbound						Humboldt Pkwy Northbound						Total
	Thru	Left	U-Turn	App Total	Peds CW	Peds CCW	Right	Left	U-Turn	App Total	Peds CW	Peds CCW	Right	Thru	U-Turn	App Total	Peds CW	Peds CCW	
Start Time																			
6:30:00 AM	0	0	0	0	0	0	7	0	0	7	1	1	6	62	0	70	0	0	
6:45:00 AM	0	0	0	0	0	0	4	0	0	4	0	0	10	63	0	73	0	0	
<b>Hourly Total</b>	<b>0</b>	<b>0</b>	<b>0</b>	<b>0</b>	<b>0</b>	<b>0</b>	<b>11</b>	<b>0</b>	<b>0</b>	<b>11</b>	<b>1</b>	<b>1</b>	<b>16</b>	<b>125</b>	<b>0</b>	<b>143</b>	<b>0</b>	<b>0</b>	
7:00:00 AM	0	0	0	0	0	0	12	0	0	12	0	0	15	72	0	87	0	0	
7:15:00 AM	0	0	0	0	0	0	13	0	0	13	0	0	11	57	0	68	0	0	
7:30:00 AM	0	0	0	0	0	0	17	0	0	17	3	0	12	106	0	121	0	0	
7:45:00 AM	0	0	0	0	0	0	16	0	0	16	0	0	20	116	0	136	0	0	
<b>Hourly Total</b>	<b>0</b>	<b>0</b>	<b>0</b>	<b>0</b>	<b>0</b>	<b>0</b>	<b>58</b>	<b>0</b>	<b>0</b>	<b>58</b>	<b>3</b>	<b>0</b>	<b>58</b>	<b>351</b>	<b>0</b>	<b>412</b>	<b>0</b>	<b>0</b>	
8:00:00 AM	0	0	0	0	0	0	12	0	0	12	0	0	8	107	0	115	0	0	
8:15:00 AM	0	0	0	0	0	0	9	0	0	9	0	0	14	78	0	92	0	0	
<b>Hourly Total</b>	<b>0</b>	<b>0</b>	<b>0</b>	<b>0</b>	<b>0</b>	<b>0</b>	<b>21</b>	<b>0</b>	<b>0</b>	<b>21</b>	<b>0</b>	<b>0</b>	<b>22</b>	<b>185</b>	<b>0</b>	<b>207</b>	<b>0</b>	<b>0</b>	
4:00:00 PM	0	0	0	0	0	0	24	0	0	24	0	0	12	151	0	163	0	0	
4:15:00 PM	0	0	0	0	0	0	18	0	0	18	0	0	17	148	0	165	0	0	
4:30:00 PM	0	0	0	0	0	0	15	0	0	15	0	0	14	116	0	130	0	0	
4:45:00 PM	0	0	0	0	0	0	9	0	0	9	0	0	17	119	0	136	0	0	
<b>Hourly Total</b>	<b>0</b>	<b>0</b>	<b>0</b>	<b>0</b>	<b>0</b>	<b>0</b>	<b>66</b>	<b>0</b>	<b>0</b>	<b>66</b>	<b>0</b>	<b>0</b>	<b>60</b>	<b>534</b>	<b>0</b>	<b>594</b>	<b>0</b>	<b>0</b>	
5:00:00 PM	0	0	0	0	0	0	21	0	0	21	0	0	21	138	0	159	0	0	
5:15:00 PM	0	0	0	0	0	0	11	0	0	11	0	1	8	126	0	134	0	0	
5:30:00 PM	0	0	0	0	0	0	23	0	0	23	0	0	10	133	0	143	0	0	
5:45:00 PM	0	0	0	0	0	0	12	0	0	12	0	0	9	111	0	120	0	0	
<b>Hourly Total</b>	<b>0</b>	<b>0</b>	<b>0</b>	<b>0</b>	<b>0</b>	<b>0</b>	<b>67</b>	<b>0</b>	<b>0</b>	<b>67</b>	<b>0</b>	<b>1</b>	<b>48</b>	<b>508</b>	<b>0</b>	<b>556</b>	<b>0</b>	<b>0</b>	
<b>Grand Total</b>	<b>0</b>	<b>0</b>	<b>0</b>	<b>0</b>	<b>0</b>	<b>0</b>	<b>223</b>	<b>0</b>	<b>0</b>	<b>223</b>	<b>4</b>	<b>2</b>	<b>204</b>	<b>1703</b>	<b>0</b>	<b>1912</b>	<b>0</b>	<b>0</b>	
% Approach	0.0%	0.0%	0.0%	0.0%	0.0%	0.0%	100.0%	0.0%	0.0%	0.0%	0.0%	0.0%	10.7%	89.1%	0.0%	0.0%	0.0%	0.0%	
% Total	0.0%	0.0%	0.0%	0.0%	0.0%	0.0%	10.4%	0.0%	0.0%	10.4%	0.0%	0.0%	9.6%	79.8%	0.0%	89.6%	0.0%	0.0%	
Lights	0	0	0	0	0	0	208	0	0	208	0	0	193	1647	0	1840	0	0	
% Lights	0.0%	0.0%	0.0%	0.0%	0.0%	0.0%	93.3%	0.0%	0.0%	93.3%	0.0%	0.0%	94.6%	96.7%	0.0%	96.2%	0.0%	0.0%	
Trucks	0	0	0	0	0	0	0	0	0	0	0	0	0	0	0	0	0	0	
% Trucks	0.0%	0.0%	0.0%	0.0%	0.0%	0.0%	0.0%	0.0%	0.0%	0.0%	0.0%	0.0%	0.0%	0.0%	0.0%	0.0%	0.0%	0.0%	
Buses	0	0	0	0	0	0	15	0	0	15	0	0	11	54	0	65	0	0	
% Buses	0.0%	0.0%	0.0%	0.0%	0.0%	0.0%	0.0%	0.0%	0.0%	0.0%	0.0%	0.0%	5.4%	3.2%	0.0%	0.0%	0.0%	0.0%	
Pedestrians	0	0	0	0	0	0	0	0	0	0	4	1	0	0	0	0	0	0	
% Pedestrians	0.0%	0.0%	0.0%	0.0%	0.0%	0.0%	0.0%	0.0%	0.0%	0.0%	100.0%	50.0%	0.0%	0.0%	0.0%	0.0%	0.0%	0.0%	
Bicycles on Crosswalk	0	0	0	0	0	0	0	0	0	0	0	1	0	0	0	0	0	0	
% Bicycles on Crosswalk	0.0%	0.0%	0.0%	0.0%	0.0%	0.0%	0.0%	0.0%	0.0%	0.0%	0.0%	50.0%	0.0%	0.0%	0.0%	0.0%	0.0%	0.0%	

Turning Movement Data Plot

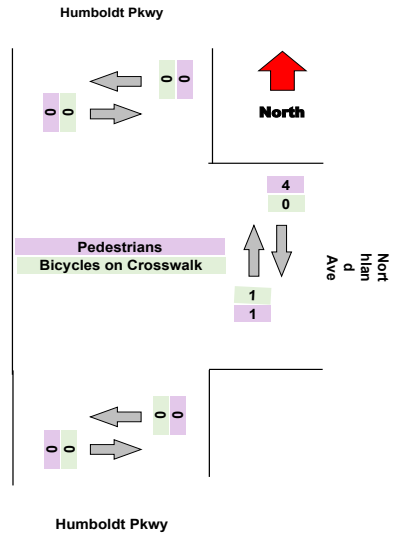
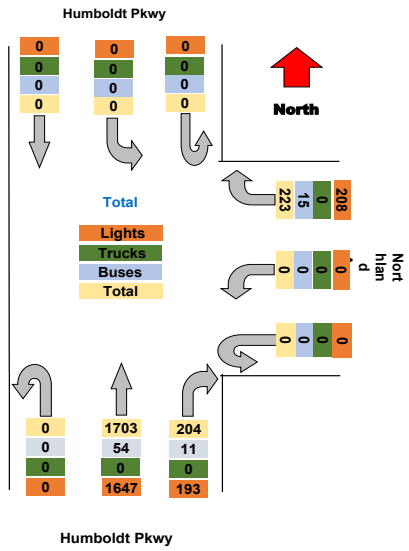

Turning Movement Peak Hour Data (AM)  
 7:30:00 AM

Leg Direction	Humboldt Pkwy Southbound						Northland Ave Westbound						Humboldt Pkwy Northbound						Total
	Thru	Left	U-Turn	App Total	Peds CW	Peds CCW	Right	Left	U-Turn	App Total	Peds CW	Peds CCW	Right	Thru	U-Turn	App Total	Peds CW	Peds CCW	
7:30:00 AM	0	0	0	0	0	0	17	0	0	17	3	0	12	106	0	121	0	0	138
7:45:00 AM	0	0	0	0	0	0	16	0	0	16	0	0	20	116	0	136	0	0	152
8:00:00 AM	0	0	0	0	0	0	12	0	0	12	0	0	8	107	0	115	0	0	127
8:15:00 AM	0	0	0	0	0	0	9	0	0	9	0	0	14	78	0	92	0	0	101
<b>Grand Total</b>	<b>0</b>	<b>0</b>	<b>0</b>	<b>0</b>	<b>0</b>	<b>0</b>	<b>54</b>	<b>0</b>	<b>0</b>	<b>54</b>	<b>3</b>	<b>0</b>	<b>54</b>	<b>407</b>	<b>0</b>	<b>464</b>	<b>0</b>	<b>0</b>	<b>518</b>
% Approach	#####	#####	#####	0.0%	0.0%	0.0%	14.2%	0.0%	0.0%	0.0%	0.0%	0.0%	45.1%	41.7%	0.0%	0.0%	0.0%	0.0%	
% Total	0.0%	0.0%	0.0%	0.0%	0.0%	0.0%	10.4%	0.0%	0.0%	10.4%	0.0%	0.0%	10.4%	78.6%	0.0%	89.6%	0.0%	0.0%	
PHF	0.000	0.000	0.000	0.000	0.000	0.000	0.794	0.000	0.000	0.794	0.000	0.000	0.675	0.877	0.000	0.853	0.000	0.000	0.852
Lights	0	0	0	0	0	0	50	0	0	50	0	0	51	397	0	448	0	0	498
% Lights	0.0%	0.0%	0.0%	0.0%	0.0%	0.0%	92.6%	0.0%	0.0%	92.6%	0.0%	0.0%	94.4%	97.5%	0.0%	96.6%	0.0%	0.0%	96.1%
Trucks	0	0	0	0	0	0	0	0	0	0	0	0	0	0	0	0	0	0	0
% Trucks	0.0%	0.0%	0.0%	0.0%	0.0%	0.0%	0.0%	0.0%	0.0%	0.0%	0.0%	0.0%	0.0%	0.0%	0.0%	0.0%	0.0%	0.0%	0.0%
Buses	0	0	0	0	0	0	4	0	0	4	0	0	3	10	0	13	0	0	17
% Buses	0.0%	0.0%	0.0%	0.0%	0.0%	0.0%	7.4%	0.0%	0.0%	0.0%	0.0%	0.0%	5.6%	2.5%	0.0%	0.0%	0.0%	0.0%	3.3%
Pedestrians	0	0	0	0	0	0	0	0	0	0	3	0	0	0	0	0	0	0	0
% Pedestrians	0.0%	0.0%	0.0%	0.0%	0.0%	0.0%	0.0%	0.0%	0.0%	0.0%	100.0%	0.0%	0.0%	0.0%	0.0%	0.0%	0.0%	0.0%	0.0%
Bicycles on Crosswalk	0	0	0	0	0	0	0	0	0	0	0	0	0	0	0	0	0	0	0
% Bicycles on Crosswalk	0.0%	0.0%	0.0%	0.0%	0.0%	0.0%	0.0%	0.0%	0.0%	0.0%	0.0%	0.0%	0.0%	0.0%	0.0%	0.0%	0.0%	0.0%	0.0%

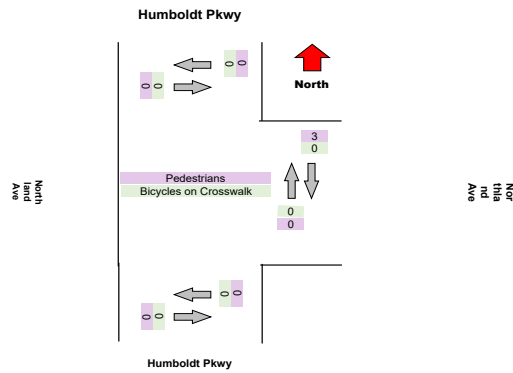
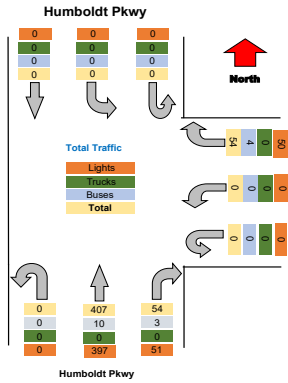

Turning Movement Peak Hour Data (PM)  
 4:30:00 PM

Leg Direction	Humboldt Pkwy						Northland Ave						Humboldt Pkwy						Total
	Southbound			Westbound			Northbound			Northbound									
Start Time	Thru	Left	U-Turn	App Total	Peds CW	Peds CCW	Right	Left	U-Turn	App Total	Peds CW	Peds CCW	Right	Thru	U-Turn	App Total	Peds CW	Peds CCW	
4:30:00 PM	0	0	0	0	0	0	15	0	0	15	0	0	14	116	0	130	0	0	145
4:45:00 PM	0	0	0	0	0	0	9	0	0	9	0	0	17	119	0	136	0	0	145
5:00:00 PM	0	0	0	0	0	0	21	0	0	21	0	0	21	138	0	159	0	0	180
5:15:00 PM	0	0	0	0	0	0	11	0	0	11	0	1	8	126	0	134	0	0	145
<b>Grand Total</b>	<b>0</b>	<b>0</b>	<b>0</b>	<b>0</b>	<b>0</b>	<b>0</b>	<b>56</b>	<b>0</b>	<b>0</b>	<b>56</b>	<b>0</b>	<b>1</b>	<b>60</b>	<b>499</b>	<b>0</b>	<b>559</b>	<b>0</b>	<b>0</b>	<b>615</b>
% Approach	#####	#####	#####	0.0%	0.0%	0.0%	14.2%	0.0%	0.0%	0.0%	0.0%	0.0%	45.1%	41.7%	0.0%	0.0%	0.0%	0.0%	
% Total	0.0%	0.0%	0.0%	0.0%	0.0%	0.0%	9.1%	0.0%	0.0%	9.1%	0.0%	0.0%	9.8%	81.1%	0.0%	90.9%	0.0%	0.0%	
PHF	0.000	0.000	0.000	0.000	0.000	0.000	0.667	0.000	0.000	0.667	0.000	0.000	0.714	0.904	0.000	0.879	0.000	0.000	0.854
Lights	0	0	0	0	0	0	56	0	0	56	0	0	55	493	0	548	0	0	604
% Lights	0.0%	0.0%	0.0%	0.0%	0.0%	0.0%	100.0%	0.0%	0.0%	100.0%	0.0%	0.0%	91.7%	98.8%	0.0%	98.0%	0.0%	0.0%	98.2%
Trucks	0	0	0	0	0	0	0	0	0	0	0	0	0	0	0	0	0	0	0
% Trucks	0.0%	0.0%	0.0%	0.0%	0.0%	0.0%	0.0%	0.0%	0.0%	0.0%	0.0%	0.0%	0.0%	0.0%	0.0%	0.0%	0.0%	0.0%	0.0%
Buses	0	0	0	0	0	0	0	0	0	0	0	0	5	6	0	11	0	0	11
% Buses	0.0%	0.0%	0.0%	0.0%	0.0%	0.0%	0.0%	0.0%	0.0%	0.0%	0.0%	0.0%	8.3%	1.2%	0.0%	0.0%	0.0%	0.0%	1.8%
Pedestrians	0	0	0	0	0	0	0	0	0	0	0	0	0	0	0	0	0	0	0
% Pedestrians	0.0%	0.0%	0.0%	0.0%	0.0%	0.0%	0.0%	0.0%	0.0%	0.0%	0.0%	0.0%	0.0%	0.0%	0.0%	0.0%	0.0%	0.0%	0.0%
Bicycles on Crosswalk	0	0	0	0	0	0	0	0	0	0	0	1	0	0	0	0	0	0	0
% Bicycles on Crosswalk	0.0%	0.0%	0.0%	0.0%	0.0%	0.0%	0.0%	0.0%	0.0%	0.0%	0.0%	100.0%	0.0%	0.0%	0.0%	0.0%	0.0%	0.0%	0.0%

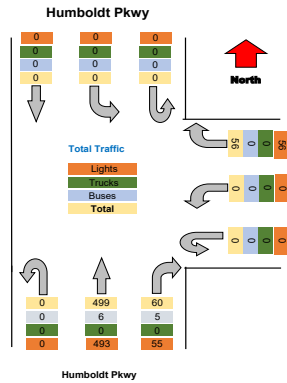

North  
 and  
 Ave

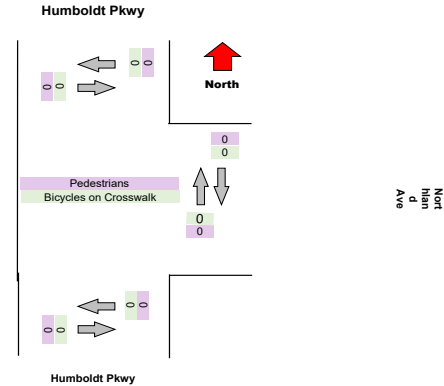

North  
 and  
 Ave



Turning Movement Data Plot

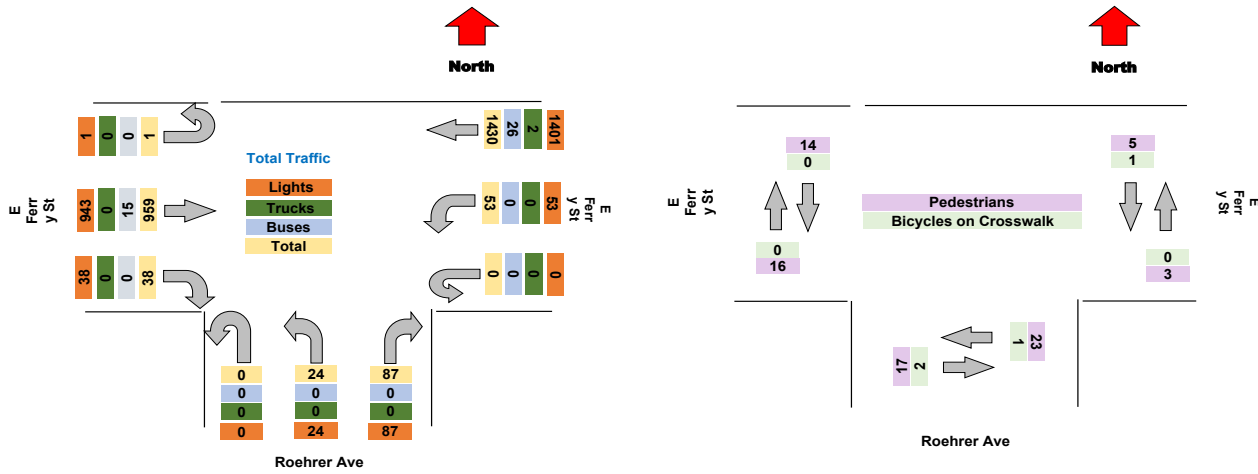

Turning Movement Peak Hour Data (AM)  
7:30:00 AM

Leg Direction	E Ferry St Westbound						Roehrer Ave Northbound						E Ferry St Eastbound						Total
	Thru	Left	U-Turn	App Total	Peds CW	Peds CCW	Right	Left	U-Turn	App Total	Peds CW	Peds CCW	Right	Thru	U-Turn	App Total	Peds CW	Peds CCW	
7:30:00 AM	73	1	0	74	0	0	2	0	0	2	0	0	0	37	0	37	0	0	113
7:45:00 AM	117	1	0	118	0	0	1	0	0	1	0	0	0	43	0	43	0	0	162
8:00:00 AM	100	3	0	103	0	0	1	1	0	2	0	0	0	42	0	42	0	0	147
8:15:00 AM	78	0	0	78	0	0	5	0	0	5	0	0	0	49	0	49	0	0	132
<b>Grand Total</b>	<b>368</b>	<b>5</b>	<b>0</b>	<b>373</b>	<b>0</b>	<b>0</b>	<b>9</b>	<b>1</b>	<b>0</b>	<b>10</b>	<b>0</b>	<b>0</b>	<b>0</b>	<b>171</b>	<b>0</b>	<b>171</b>	<b>0</b>	<b>0</b>	<b>554</b>
% Approach	98.7%	1.3%	0.0%	0.0%	0.0%	0.0%	90.0%	10.0%	0.0%	0.0%	0.0%	0.0%	0.0%	#####	0.0%	0.0%	0.0%	0.0%	
% Total	66.4%	0.9%	0.0%	67.3%	0.0%	0.0%	1.6%	0.2%	0.0%	1.8%	0.0%	0.0%	0.0%	30.9%	0.0%	30.9%	0.0%	0.0%	
PHF	0.786	0.417	0.000	0.790	0.000	0.000	0.450	0.250	0.000	0.500	0.000	0.000	0.000	0.872	0.000	0.872	0.000	0.000	0.855
Lights	360	5	0	365	0	0	9	1	0	10	0	0	0	168	0	168	0	0	543
% Lights	97.8%	100.0%	0.0%	97.9%	0.0%	0.0%	100.0%	100.0%	0.0%	100.0%	0.0%	0.0%	0.0%	98.2%	0.0%	98.2%	0.0%	0.0%	98.0%
Trucks	1	0	0	1	0	0	0	0	0	0	0	0	0	0	0	0	0	0	1
% Trucks	0.3%	0.0%	0.0%	0.3%	0.0%	0.0%	0.0%	0.0%	0.0%	0.0%	0.0%	0.0%	0.0%	0.0%	0.0%	0.0%	0.0%	0.0%	0.2%
Buses	6	0	0	6	0	0	0	0	0	0	0	0	0	3	0	3	0	0	9
% Buses	1.6%	0.0%	0.0%	0.0%	0.0%	0.0%	0.0%	0.0%	0.0%	0.0%	0.0%	0.0%	0.0%	1.8%	0.0%	0.0%	0.0%	0.0%	1.6%
Pedestrians	0	0	0	0	0	0	0	0	0	0	0	0	0	0	0	0	0	0	0
% Pedestrians	0.0%	0.0%	0.0%	0.0%	0.0%	0.0%	0.0%	0.0%	0.0%	0.0%	0.0%	0.0%	0.0%	0.0%	0.0%	0.0%	0.0%	0.0%	0.0%
Bicycles on Crosswalk	0	0	0	0	0	0	0	0	0	0	0	0	0	0	0	0	0	0	0
% Bicycles on Crosswalk	0.0%	0.0%	0.0%	0.0%	0.0%	0.0%	0.0%	0.0%	0.0%	0.0%	0.0%	0.0%	0.0%	0.0%	0.0%	0.0%	0.0%	0.0%	0.0%

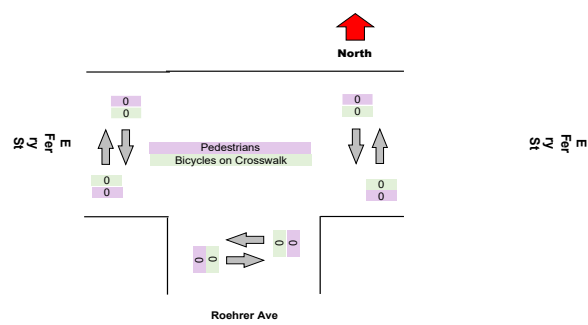
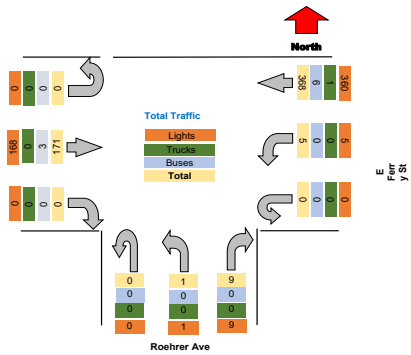

Turning Movement Peak Hour Data (PM)

4:30:00 PM

Leg Direction	E Ferry St Westbound						Roehrer Ave Northbound						E Ferry St Eastbound						Total
	Thru	Left	U-Turn	App Total	Peds CW	Peds CCW	Right	Left	U-Turn	App Total	Peds CW	Peds CCW	Right	Thru	U-Turn	App Total	Peds CW	Peds CCW	
4:30:00 PM	105	6	0	111	0	0	6	2	0	8	3	1	4	85	0	89	1	2	208
4:45:00 PM	97	5	0	102	1	0	6	5	0	11	3	2	6	83	0	89	3	1	202
5:00:00 PM	91	3	0	94	1	1	18	5	0	23	2	2	2	93	1	96	2	1	213
5:15:00 PM	131	3	0	134	3	0	11	3	0	14	6	5	4	88	0	92	2	2	240
<b>Grand Total</b>	<b>424</b>	<b>17</b>	<b>0</b>	<b>441</b>	<b>5</b>	<b>1</b>	<b>41</b>	<b>15</b>	<b>0</b>	<b>56</b>	<b>14</b>	<b>10</b>	<b>16</b>	<b>349</b>	<b>1</b>	<b>366</b>	<b>8</b>	<b>6</b>	<b>863</b>
% Approach	96.1%	3.9%	0.0%	0.0%	0.0%	0.0%	73.2%	26.8%	0.0%	0.0%	0.0%	0.0%	4.4%	95.4%	0.3%	0.0%	0.0%	0.0%	
% Total	49.1%	2.0%	0.0%	51.1%	0.0%	0.0%	4.8%	1.7%	0.0%	6.5%	0.0%	0.0%	1.9%	40.4%	0.1%	42.4%	0.0%	0.0%	
PHF	0.809	0.708	0.000	0.823	0.000	0.000	0.569	0.750	0.000	0.609	0.000	0.000	0.667	0.938	0.250	0.953	0.000	0.000	0.899
Lights	418	17	0	435	0	0	41	15	0	56	0	0	16	344	1	361	0	0	852
% Lights	98.6%	100.0%	0.0%	98.6%	0.0%	0.0%	100.0%	100.0%	0.0%	100.0%	0.0%	0.0%	100.0%	98.6%	100.0%	98.6%	0.0%	0.0%	98.7%
Trucks	1	0	0	1	0	0	0	0	0	0	0	0	0	0	0	0	0	0	1
% Trucks	0.2%	0.0%	0.0%	0.2%	0.0%	0.0%	0.0%	0.0%	0.0%	0.0%	0.0%	0.0%	0.0%	0.0%	0.0%	0.0%	0.0%	0.0%	0.1%
Buses	5	0	0	5	0	0	0	0	0	0	0	0	0	5	0	5	0	0	10
% Buses	1.2%	0.0%	0.0%	0.0%	0.0%	0.0%	0.0%	0.0%	0.0%	0.0%	0.0%	0.0%	0.0%	1.4%	0.0%	0.0%	0.0%	0.0%	1.2%
Pedestrians	0	0	0	0	4	1	0	0	0	0	13	9	0	0	0	8	6	0	
% Pedestrians	0.0%	0.0%	0.0%	0.0%	80.0%	100.0%	0.0%	0.0%	0.0%	0.0%	92.9%	90.0%	0.0%	0.0%	0.0%	0.0%	100.0%	100.0%	0.0%
Bicycles on Crosswalk	0	0	0	0	1	0	0	0	0	1	1	0	0	0	0	0	0	0	
% Bicycles on Crosswalk	0.0%	0.0%	0.0%	0.0%	20.0%	0.0%	0.0%	0.0%	0.0%	0.0%	7.1%	10.0%	0.0%	0.0%	0.0%	0.0%	0.0%	0.0%	0.0%

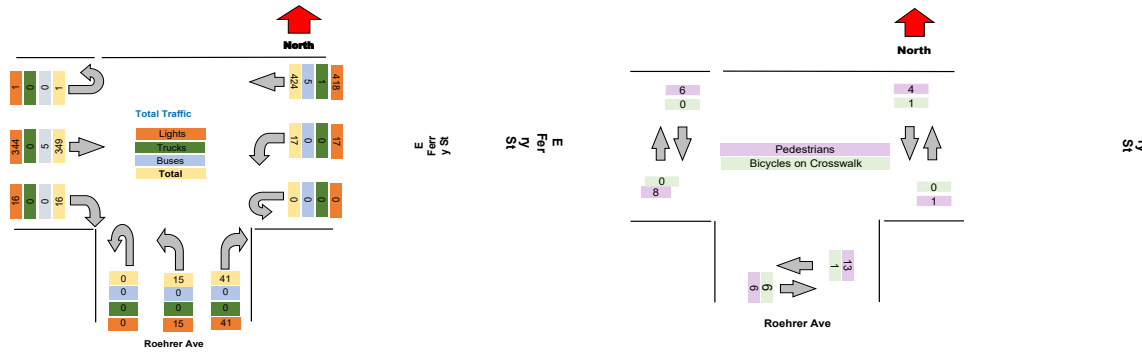





Turning Movement Data Plot

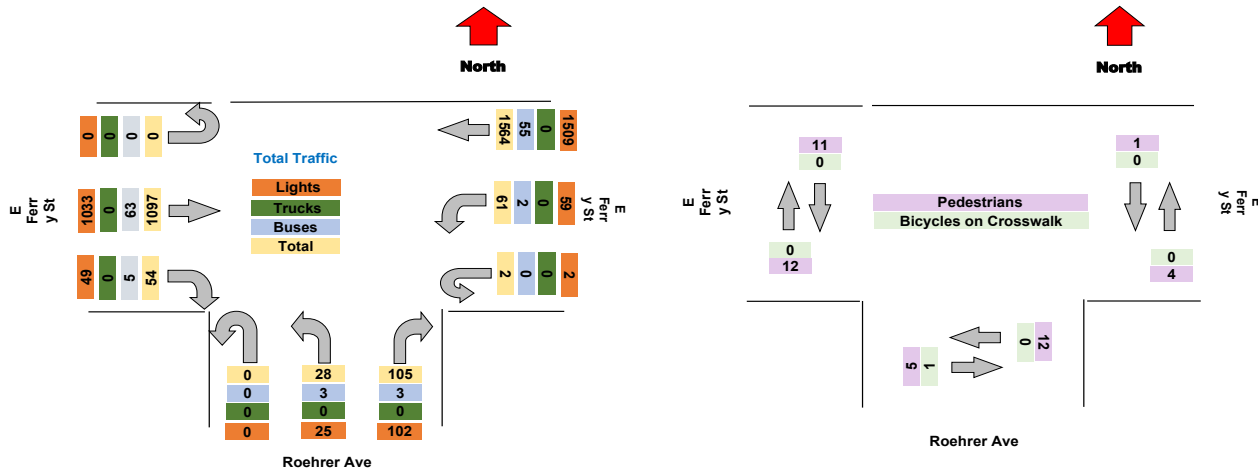

Turning Movement Peak Hour Data (AM)

7:30:00 AM

Leg Direction	E Ferry St Westbound						Roehrer Ave Northbound						E Ferry St Eastbound						Total
	Thru	Left	U-Turn	App Total	Peds CW	Peds CCW	Right	Left	U-Turn	App Total	Peds CW	Peds CCW	Right	Thru	U-Turn	App Total	Peds CW	Peds CCW	
7:30:00 AM	123	3	0	126	0	0	3	0	0	3	0	0	1	65	0	66	0	0	195
7:45:00 AM	146	2	0	148	0	2	5	0	0	3	1	0	4	77	0	82	0	0	237
8:00:00 AM	117	7	0	124	0	0	2	1	0	7	0	0	2	60	0	62	0	0	189
8:15:00 AM	82	6	0	88	0	0	1	0	0	1	0	0	2	53	0	55	0	0	144
<b>Grand Total</b>	468	18	0	486	0	2	11	1	0	14	1	0	9	255	0	265	0	0	765
% Approach	96.3%	3.7%	0.0%	0.0%	0.0%	0.0%	78.6%	7.1%	0.0%	0.0%	0.0%	0.0%	3.4%	96.2%	0.0%	0.0%	0.0%	0.0%	
% Total	61.2%	2.4%	0.0%	63.5%	0.0%	0.0%	1.4%	0.1%	0.0%	1.8%	0.0%	0.0%	1.2%	33.3%	0.0%	34.6%	0.0%	0.0%	
PHF	0.801	0.643	0.000	0.821	0.000	0.000	0.550	0.250	0.000	0.500	0.000	0.000	0.563	0.828	0.000	0.808	0.000	0.000	0.807
Lights	448	16	0	464	0	0	11	0	0	11	0	0	8	229	0	237	0	0	712
% Lights	95.7%	88.9%	0.0%	95.5%	0.0%	0.0%	100.0%	0.0%	0.0%	78.6%	0.0%	0.0%	88.9%	89.8%	0.0%	89.4%	0.0%	0.0%	93.1%
Trucks	0	0	0	0	0	0	0	0	0	0	0	0	0	0	0	0	0	0	0
% Trucks	0.0%	0.0%	0.0%	0.0%	0.0%	0.0%	0.0%	0.0%	0.0%	0.0%	0.0%	0.0%	0.0%	0.0%	0.0%	0.0%	0.0%	0.0%	0.0%
Buses	20	2	0	22	0	0	0	1	0	1	0	0	1	26	0	27	0	0	50
% Buses	4.3%	11.1%	0.0%	0.0%	0.0%	0.0%	0.0%	100.0%	0.0%	0.0%	0.0%	0.0%	11.1%	10.2%	0.0%	0.0%	0.0%	0.0%	6.5%
Pedestrians	0	0	0	0	0	2	0	0	0	0	1	0	0	0	0	0	0	0	0
% Pedestrians	0.0%	0.0%	0.0%	0.0%	0.0%	100.0%	0.0%	0.0%	0.0%	0.0%	100.0%	0.0%	0.0%	0.0%	0.0%	0.0%	0.0%	0.0%	0.0%
Bicycles on Crosswalk	0	0	0	0	0	0	0	0	0	0	0	0	0	0	0	0	0	0	0
% Bicycles on Crosswalk	0.0%	0.0%	0.0%	0.0%	0.0%	0.0%	0.0%	0.0%	0.0%	0.0%	0.0%	0.0%	0.0%	0.0%	0.0%	0.0%	0.0%	0.0%	0.0%

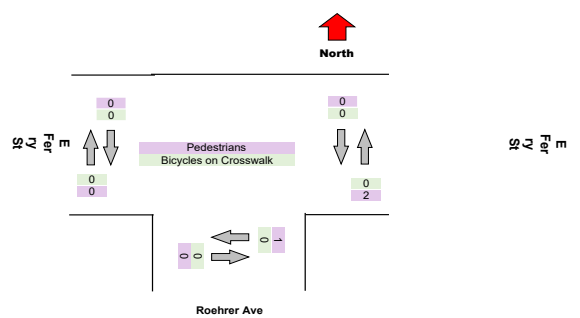
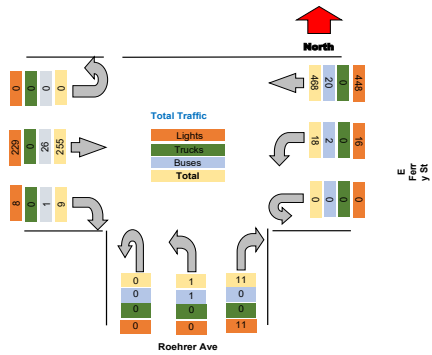

**Turning Movement Peak Hour Data (PM)**  
4:30:00 PM

Leg Direction	E Ferry St Westbound						Roehrer Ave Northbound						E Ferry St Eastbound						Total
	Thru	Left	U-Turn	App Total	Peds CW	Peds CCW	Right	Left	U-Turn	App Total	Peds CW	Peds CCW	Right	Thru	U-Turn	App Total	Peds CW	Peds CCW	
4:30:00 PM	100	3	0	103	0	1	9	2	0	11	0	0	5	95	0	100	2	1	214
4:45:00 PM	98	2	2	102	0	0	8	4	0	12	3	1	7	83	0	90	1	1	204
5:00:00 PM	103	6	0	109	0	0	10	2	0	12	5	0	8	82	0	90	1	1	211
5:15:00 PM	123	2	0	125	0	0	10	5	0	15	0	1	7	90	0	97	0	1	237
<b>Grand Total</b>	<b>424</b>	<b>13</b>	<b>2</b>	<b>439</b>	<b>0</b>	<b>1</b>	<b>37</b>	<b>13</b>	<b>0</b>	<b>50</b>	<b>8</b>	<b>2</b>	<b>27</b>	<b>350</b>	<b>0</b>	<b>377</b>	<b>4</b>	<b>4</b>	<b>866</b>
% Approach	96.6%	3.0%	0.5%	0.0%	0.0%	0.0%	74.0%	26.0%	0.0%	0.0%	0.0%	0.0%	7.2%	92.8%	0.0%	0.0%	0.0%	0.0%	0.0%
% Total	49.0%	1.5%	0.2%	50.7%	0.0%	0.0%	4.3%	1.5%	0.0%	5.8%	0.0%	0.0%	3.1%	40.4%	0.0%	43.5%	0.0%	0.0%	0.0%
PHF	0.862	0.542	0.250	0.878	0.000	0.000	0.925	0.650	0.000	0.833	0.000	0.000	0.844	0.921	0.000	0.943	0.000	0.000	0.914
Lights	412	13	2	427	0	0	37	11	0	48	0	0	26	338	0	364	0	0	839
% Lights	97.2%	100.0%	100.0%	97.3%	0.0%	0.0%	100.0%	84.6%	0.0%	96.0%	0.0%	0.0%	96.3%	96.6%	0.0%	96.6%	0.0%	0.0%	96.9%
Trucks	0	0	0	0	0	0	0	0	0	0	0	0	0	0	0	0	0	0	0
% Trucks	0.0%	0.0%	0.0%	0.0%	0.0%	0.0%	0.0%	0.0%	0.0%	0.0%	0.0%	0.0%	0.0%	0.0%	0.0%	0.0%	0.0%	0.0%	0.0%
Buses	12	0	0	12	0	0	0	2	0	2	0	0	1	11	0	12	0	0	25
% Buses	2.8%	0.0%	0.0%	0.0%	0.0%	0.0%	0.0%	15.4%	0.0%	0.0%	0.0%	0.0%	3.7%	3.1%	0.0%	0.0%	0.0%	0.0%	3.0%
Pedestrians	0	0	0	0	0	1	0	0	0	0	8	1	0	0	0	0	4	4	0
% Pedestrians	0.0%	0.0%	0.0%	0.0%	0.0%	100.0%	0.0%	0.0%	0.0%	0.0%	100.0%	50.0%	0.0%	0.0%	0.0%	0.0%	100.0%	100.0%	0.0%
Bicycles on Crosswalk	0	0	0	0	0	0	0	0	0	0	1	0	0	0	0	0	0	0	0
% Bicycles on Crosswalk	0.0%	0.0%	0.0%	0.0%	0.0%	0.0%	0.0%	0.0%	0.0%	0.0%	50.0%	0.0%	0.0%	0.0%	0.0%	0.0%	0.0%	0.0%	0.0%

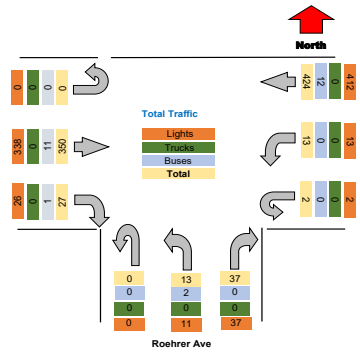

E Ferry St

E Ferry St

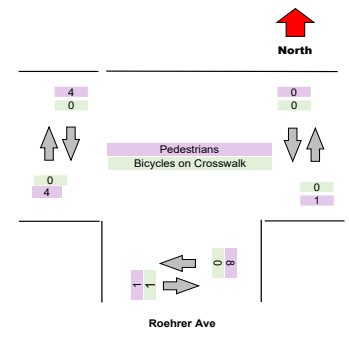

E Ferry St



Turning Movement Data Plot

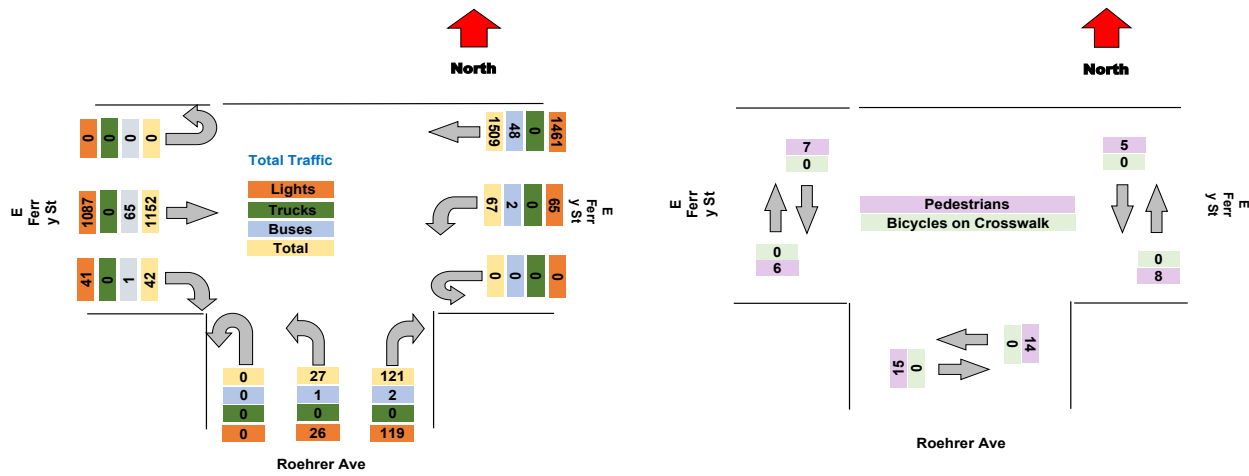

Turning Movement Peak Hour Data (AM)  
7:30:00 AM

Leg Direction	E Ferry St Westbound						Roehrer Ave Northbound						E Ferry St Eastbound						Total	
	Thru	Left	U-Turn	App Total	Peds CW	Peds CCW	Right	Left	U-Turn	App Total	Peds CW	Peds CCW	Right	Thru	U-Turn	App Total	Peds CW	Peds CCW		
7:30:00 AM	116	2	0	118	0	1	3	0	0	4	0	0	0	60	0	0	60	0	0	182
7:45:00 AM	147	4	0	151	0	0	4	0	0	4	0	0	3	87	0	90	0	0	245	
8:00:00 AM	118	3	0	121	0	2	6	2	0	10	0	0	3	72	0	75	1	1	206	
8:15:00 AM	81	5	0	86	0	0	5	0	0	5	0	0	2	64	0	66	0	0	157	
<b>Grand Total</b>	462	14	0	476	0	3	18	2	0	23	0	0	8	283	0	291	1	1	790	
% Approach	97.1%	2.9%	0.0%	0.0%	0.0%	0.0%	78.3%	8.7%	0.0%	0.0%	0.0%	0.0%	2.7%	97.3%	0.0%	0.0%	0.0%	0.0%		
% Total	58.5%	1.8%	0.0%	60.3%	0.0%	0.0%	2.3%	0.3%	0.0%	2.9%	0.0%	0.0%	1.0%	35.8%	0.0%	36.8%	0.0%	0.0%		
PHF	0.786	0.700	0.000	0.788	0.000	0.000	0.750	0.250	0.000	0.575	0.000	0.000	0.667	0.813	0.000	0.808	0.000	0.000	0.806	
Lights	441	12	0	453	0	0	18	2	0	20	0	0	7	262	0	269	0	0	742	
% Lights	95.5%	85.7%	0.0%	95.2%	0.0%	0.0%	100.0%	100.0%	0.0%	87.0%	0.0%	0.0%	87.5%	92.6%	0.0%	92.4%	0.0%	0.0%	93.9%	
Trucks	0	0	0	0	0	0	0	0	0	0	0	0	0	0	0	0	0	0	0	
% Trucks	0.0%	0.0%	0.0%	0.0%	0.0%	0.0%	0.0%	0.0%	0.0%	0.0%	0.0%	0.0%	0.0%	0.0%	0.0%	0.0%	0.0%	0.0%	0.0%	
Buses	21	2	0	23	0	0	0	0	0	0	0	0	1	21	0	22	0	0	45	
% Buses	4.5%	14.3%	0.0%	0.0%	0.0%	0.0%	0.0%	0.0%	0.0%	0.0%	0.0%	0.0%	12.5%	7.4%	0.0%	0.0%	0.0%	0.0%	5.7%	
Pedestrians	0	0	0	0	0	3	0	0	0	0	0	0	0	0	0	0	1	1	0	
% Pedestrians	0.0%	0.0%	0.0%	0.0%	0.0%	100.0%	0.0%	0.0%	0.0%	0.0%	0.0%	0.0%	0.0%	0.0%	0.0%	0.0%	100.0%	100.0%	0.0%	
Bicycles on Crosswalk	0	0	0	0	0	0	0	0	0	0	0	0	0	0	0	0	0	0	0	
% Bicycles on Crosswalk	0.0%	0.0%	0.0%	0.0%	0.0%	0.0%	0.0%	0.0%	0.0%	0.0%	0.0%	0.0%	0.0%	0.0%	0.0%	0.0%	0.0%	0.0%	0.0%	

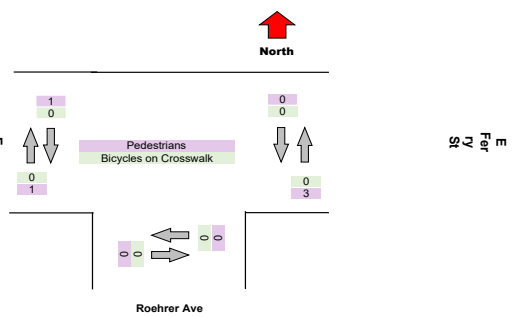
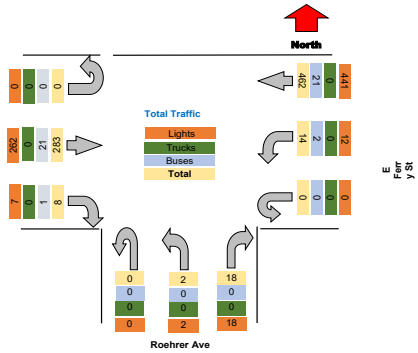

Turning Movement Peak Hour Data (PM)  
4:30:00 PM

Leg Direction	E Ferry St Westbound						Roehrer Ave Northbound						E Ferry St Eastbound						Total
	Thru	Left	U-Turn	App Total	Peds CW	Peds CCW	Right	Left	U-Turn	App Total	Peds CW	Peds CCW	Right	Thru	U-Turn	App Total	Peds CW	Peds CCW	
4:30:00 PM	105	6	0	111	0	2	12	0	0	12	1	2	3	119	0	122	1	0	245
4:45:00 PM	111	6	0	117	1	1	6	4	0	10	2	3	2	90	0	92	0	1	219
5:00:00 PM	95	10	0	105	0	1	10	5	0	15	1	3	5	90	0	95	1	1	215
5:15:00 PM	122	3	0	125	0	0	9	6	0	15	5	2	3	82	0	85	0	1	225
<b>Grand Total</b>	<b>433</b>	<b>25</b>	<b>0</b>	<b>458</b>	<b>1</b>	<b>4</b>	<b>37</b>	<b>15</b>	<b>0</b>	<b>52</b>	<b>9</b>	<b>10</b>	<b>13</b>	<b>381</b>	<b>0</b>	<b>394</b>	<b>2</b>	<b>3</b>	<b>904</b>
% Approach	94.5%	5.5%	0.0%	0.0%	0.0%	0.0%	71.2%	28.8%	0.0%	0.0%	0.0%	0.0%	3.3%	96.7%	0.0%	0.0%	0.0%	0.0%	
% Total	47.9%	2.8%	0.0%	50.7%	0.0%	0.0%	4.1%	1.7%	0.0%	5.8%	0.0%	0.0%	1.4%	42.1%	0.0%	43.6%	0.0%	0.0%	
PHF	0.887	0.625	0.000	0.916	0.000	0.000	0.771	0.625	0.000	0.867	0.000	0.000	0.650	0.800	0.000	0.807	0.000	0.000	0.922
Lights	423	25	0	448	0	0	37	14	0	51	0	0	13	367	0	380	0	0	879
% Lights	97.7%	100.0%	0.0%	97.8%	0.0%	0.0%	100.0%	93.3%	0.0%	98.1%	0.0%	0.0%	100.0%	96.3%	0.0%	96.4%	0.0%	0.0%	97.2%
Trucks	0	0	0	0	0	0	0	0	0	0	0	0	0	0	0	0	0	0	0
% Trucks	0.0%	0.0%	0.0%	0.0%	0.0%	0.0%	0.0%	0.0%	0.0%	0.0%	0.0%	0.0%	0.0%	0.0%	0.0%	0.0%	0.0%	0.0%	0.0%
Buses	10	0	0	10	0	0	0	0	0	1	0	1	0	14	0	14	0	0	25
% Buses	2.3%	0.0%	0.0%	0.0%	0.0%	0.0%	0.0%	6.7%	0.0%	0.0%	0.0%	0.0%	0.0%	3.7%	0.0%	0.0%	0.0%	0.0%	2.8%
Pedestrians	0	0	0	0	1	4	0	0	0	0	9	10	0	0	0	0	2	3	0
% Pedestrians	0.0%	0.0%	0.0%	0.0%	100.0%	100.0%	0.0%	0.0%	0.0%	0.0%	100.0%	100.0%	0.0%	0.0%	0.0%	0.0%	100.0%	100.0%	0.0%
Bicycles on Crosswalk	0	0	0	0	0	0	0	0	0	0	0	0	0	0	0	0	0	0	0
% Bicycles on Crosswalk	0.0%	0.0%	0.0%	0.0%	0.0%	0.0%	0.0%	0.0%	0.0%	0.0%	0.0%	0.0%	0.0%	0.0%	0.0%	0.0%	0.0%	0.0%	0.0%

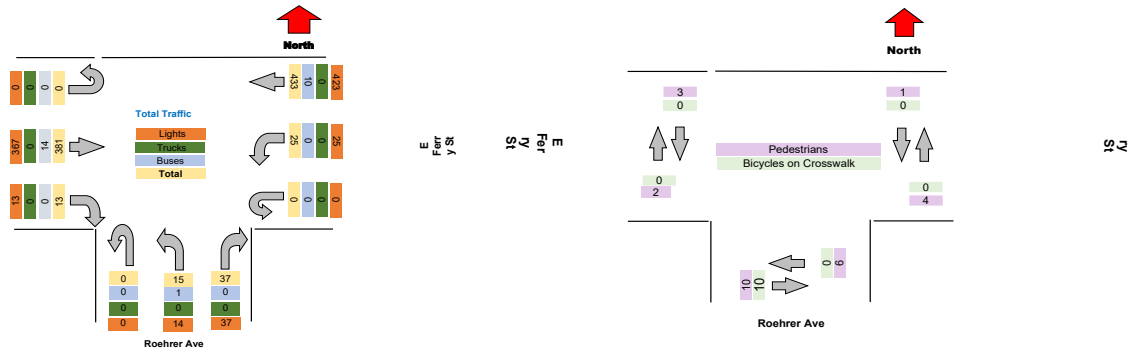





Project : VBH Malta NY  
 Site : Site 4  
 Location : 42.948550, -73.790036  
 Survey Date : 2021-04-28, Wednesday

### Turning Movement Data Plot

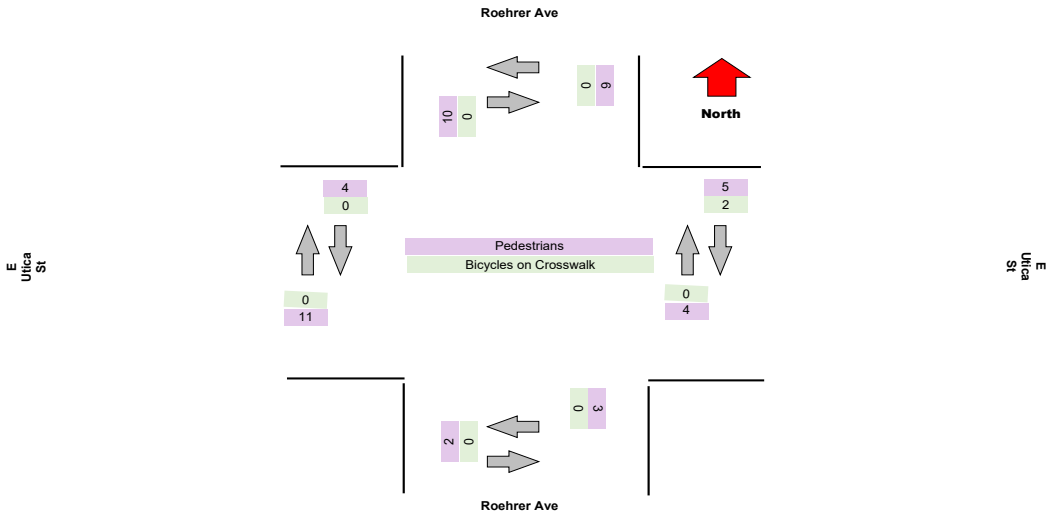
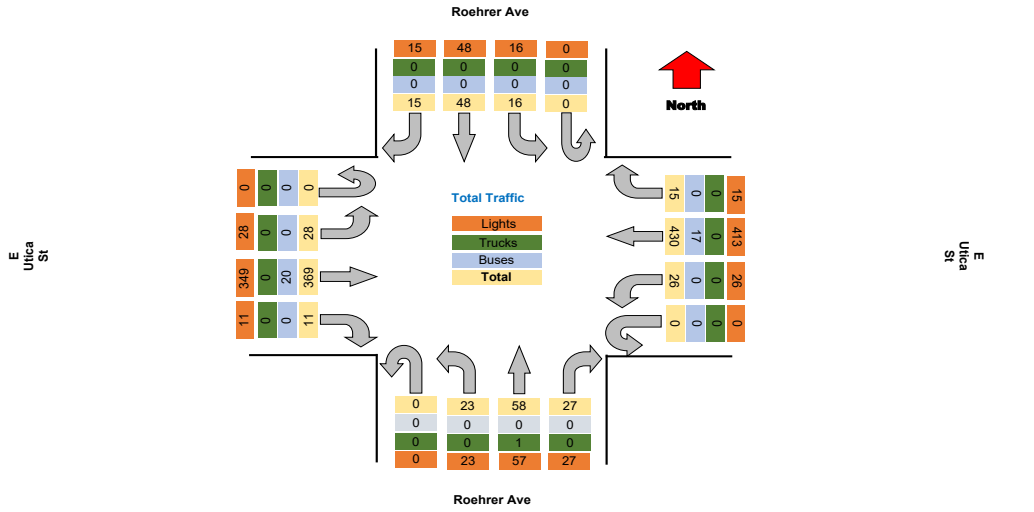

Project : VBH Malta NY  
Site : Site 4  
Location : 42.948550, -73.790036

TSTData.com

Survey Date : 2021-04-28, Wednesday

### Turning Movement Peak Hour Data (AM)

7:30:00 AM

Leg Direction	Roehrer Ave								E Ulrica St								Roehrer Ave								E Ulrica St								Total
	Southbound				Westbound				Northbound				Eastbound				Northbound				Eastbound												
Start Time	Right	Thru	Left	U-Turn	App Total	Peds CW	Peds CCW		Right	Thru	Left	U-Turn	App Total	Peds CW	Peds CCW		Right	Thru	Left	U-Turn	App Total	Peds CW	Peds CCW		Right	Thru	Left	U-Turn	App Total	Peds CW	Peds CCW		
7:30:00 AM	0	0	0	0	0	0	0	0	0	13	0	0	13	1	0	0	1	1	1	0	4	0	0	0	1	11	1	0	13	0	0	0	30
7:45:00 AM	1	0	0	0	1	0	0	0	1	20	0	0	21	0	0	0	2	3	2	0	7	0	0	0	0	15	0	0	15	0	0	0	44
8:00:00 AM	1	0	1	0	2	0	0	0	0	28	0	0	28	0	0	0	0	1	1	0	2	0	0	0	0	21	0	0	21	0	0	0	53
8:15:00 AM	0	0	0	0	0	0	0	0	1	23	1	0	25	0	0	0	1	2	0	0	3	0	0	0	0	12	1	0	13	0	0	0	41
<b>Grand Total</b>	<b>2</b>	<b>0</b>	<b>1</b>	<b>0</b>	<b>3</b>	<b>0</b>	<b>0</b>	<b>0</b>	<b>2</b>	<b>84</b>	<b>1</b>	<b>0</b>	<b>87</b>	<b>1</b>	<b>0</b>	<b>0</b>	<b>4</b>	<b>7</b>	<b>4</b>	<b>0</b>	<b>15</b>	<b>0</b>	<b>0</b>	<b>0</b>	<b>1</b>	<b>59</b>	<b>2</b>	<b>0</b>	<b>62</b>	<b>0</b>	<b>0</b>	<b>0</b>	<b>168</b>
% Approach	66.7%	0.0%	33.3%	0.0%	0.0%	0.0%	0.0%	0.0%	2.3%	96.6%	1.1%	0.0%	0.0%	0.0%	0.0%	0.0%	25.0%	43.8%	25.0%	0.0%	0.0%	0.0%	0.0%	0.0%	1.6%	95.2%	3.2%	0.0%	0.0%	0.0%	0.0%	0.0%	
% Total	1.2%	0.0%	0.6%	0.0%	1.8%	0.0%	0.0%	0.0%	1.2%	50.0%	0.6%	0.0%	51.8%	0.0%	0.0%	0.0%	2.4%	4.2%	2.4%	0.0%	9.5%	0.0%	0.0%	0.0%	0.6%	35.1%	1.2%	0.0%	36.9%	0.0%	0.0%	0.0%	
PHF	0.500	0.000	0.250	0.000	0.375	0.000	0.000	0.000	0.500	0.750	0.250	0.000	0.777	0.000	0.000	0.000	0.500	0.583	0.500	0.000	0.571	0.000	0.000	0.000	0.250	0.702	0.500	0.000	0.738	0.000	0.000	0.000	0.792
Lights	2	0	1	0	3	0	0	0	2	80	1	0	83	0	0	0	4	7	4	0	15	0	0	0	1	54	2	0	57	0	0	0	158
% Lights	100.0%	0.0%	100.0%	0.0%	100.0%	0.0%	0.0%	0.0%	100.0%	95.2%	100.0%	0.0%	95.4%	0.0%	0.0%	0.0%	100.0%	100.0%	100.0%	0.0%	93.8%	0.0%	0.0%	0.0%	100.0%	91.5%	100.0%	0.0%	91.9%	0.0%	0.0%	0.0%	94.0%
Trucks	0	0	0	0	0	0	0	0	0	0	0	0	0	0	0	0	0	0	0	0	0	0	0	0	0	0	0	0	0	0	0	0	0
% Trucks	0.0%	0.0%	0.0%	0.0%	0.0%	0.0%	0.0%	0.0%	0.0%	0.0%	0.0%	0.0%	0.0%	0.0%	0.0%	0.0%	0.0%	0.0%	0.0%	0.0%	0.0%	0.0%	0.0%	0.0%	0.0%	0.0%	0.0%	0.0%	0.0%	0.0%	0.0%	0.0%	0.0%
Buses	0	0	0	0	0	0	0	0	0	4	0	0	4	0	0	0	0	0	0	0	0	0	0	0	0	5	0	0	5	0	0	0	9
% Buses	0.0%	0.0%	0.0%	0.0%	0.0%	0.0%	0.0%	0.0%	0.0%	4.8%	0.0%	0.0%	0.0%	0.0%	0.0%	0.0%	0.0%	0.0%	0.0%	0.0%	0.0%	0.0%	0.0%	0.0%	0.0%	8.5%	0.0%	0.0%	0.0%	0.0%	0.0%	0.0%	5.4%
Pedestrians	0	0	0	0	0	0	0	0	0	0	0	0	1	0	0	0	0	0	0	0	0	0	0	0	0	0	0	0	0	0	0	0	0
% Pedestrians	0.0%	0.0%	0.0%	0.0%	0.0%	0.0%	0.0%	0.0%	0.0%	0.0%	0.0%	0.0%	0.0%	100.0%	0.0%	0.0%	0.0%	0.0%	0.0%	0.0%	0.0%	0.0%	0.0%	0.0%	0.0%	0.0%	0.0%	0.0%	0.0%	0.0%	0.0%	0.0%	0.0%
Bicycles on Crosswalk	0	0	0	0	0	0	0	0	0	0	0	0	0	0	0	0	0	0	0	0	0	0	0	0	0	0	0	0	0	0	0	0	0
% Bicycles on Crosswalk	0.0%	0.0%	0.0%	0.0%	0.0%	0.0%	0.0%	0.0%	0.0%	0.0%	0.0%	0.0%	0.0%	0.0%	0.0%	0.0%	0.0%	0.0%	0.0%	0.0%	0.0%	0.0%	0.0%	0.0%	0.0%	0.0%	0.0%	0.0%	0.0%	0.0%	0.0%	0.0%	0.0%

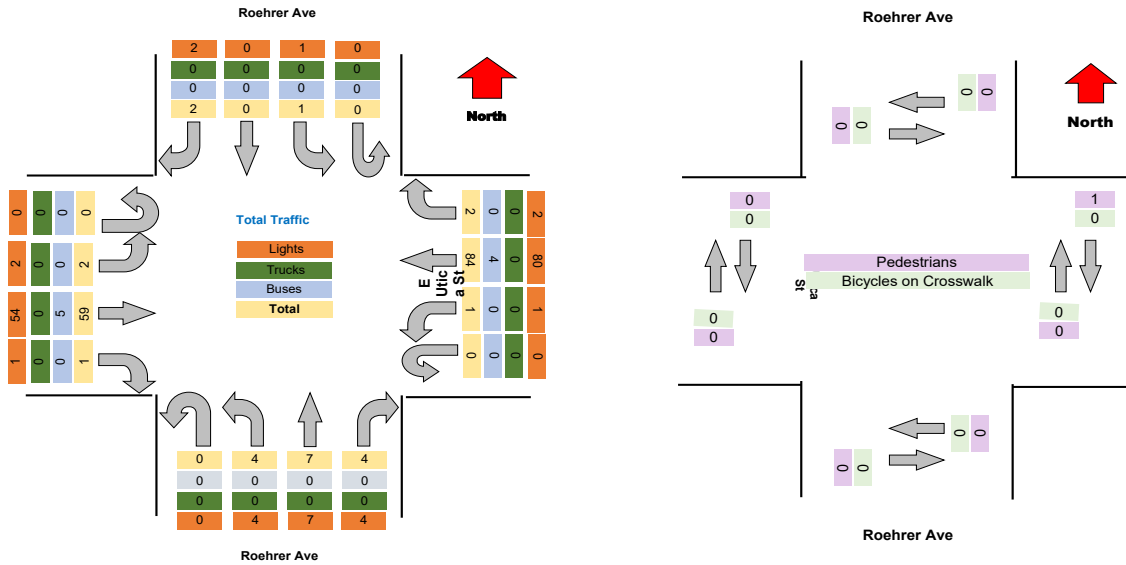

Project : VBH Malta NY  
Site : Site 4  
Location : 42.948550, -73.790036  
Survey Date : 2021-04-28, Wednesday

TSTData.com

**Turning Movement Peak Hour Data (PM)**

4:15:00 PM

Leg Direction	Roehrer Ave				E Ulica St				Roehrer Ave				E Ulica St				Total						
	Southbound				Westbound				Northbound				Eastbound										
Start Time	Right	Thru	Left	U-Turn	App Total	Peds CW	Peds CCW	Right	Thru	Left	U-Turn	App Total	Peds CW	Peds CCW	Right	Thru	Left	U-Turn	App Total	Peds CW	Peds CCW		
4:15:00 PM	2	6	4	0	12	0	0	1	33	5	0	39	1	2	0	4	3	0	7	0	0	0	90
4:30:00 PM	2	6	2	0	10	2	2	2	38	1	0	41	1	1	2	4	1	0	7	1	0	0	99
4:45:00 PM	1	4	1	0	6	3	2	3	40	5	0	48	0	0	3	7	4	0	14	0	0	0	110
5:00:00 PM	2	5	2	0	9	3	1	1	41	7	0	49	0	0	3	9	2	0	14	0	0	0	112
<b>Grand Total</b>	<b>7</b>	<b>21</b>	<b>9</b>	<b>0</b>	<b>37</b>	<b>6</b>	<b>5</b>	<b>7</b>	<b>152</b>	<b>18</b>	<b>0</b>	<b>177</b>	<b>2</b>	<b>3</b>	<b>8</b>	<b>24</b>	<b>10</b>	<b>0</b>	<b>42</b>	<b>1</b>	<b>0</b>	<b>0</b>	<b>411</b>
% Approach	18.9%	56.8%	24.3%	0.0%	0.0%	0.0%	0.0%	4.0%	85.9%	10.2%	0.0%	0.0%	0.0%	0.0%	19.0%	57.1%	23.8%	0.0%	0.0%	0.0%	0.0%	0.0%	0.0%
% Total	1.7%	5.1%	2.2%	0.0%	9.0%	0.0%	0.0%	1.7%	37.0%	4.4%	0.0%	43.1%	0.0%	0.0%	1.9%	5.8%	2.4%	0.0%	10.2%	0.0%	0.0%	0.0%	0.0%
PHF	0.875	0.875	0.563	0.000	0.771	0.000	0.000	0.583	0.927	0.643	0.000	0.903	0.000	0.000	0.667	0.667	0.625	0.000	0.750	0.000	0.000	0.000	0.917
Lights	7	21	9	0	37	0	0	7	148	18	0	173	0	0	8	24	10	0	42	0	0	0	403
% Lights	100.0%	100.0%	100.0%	0.0%	100.0%	0.0%	0.0%	100.0%	97.4%	100.0%	0.0%	97.7%	0.0%	0.0%	100.0%	100.0%	100.0%	0.0%	100.0%	0.0%	0.0%	0.0%	98.1%
Trucks	0	0	0	0	0	0	0	0	0	0	0	0	0	0	0	0	0	0	0	0	0	0	0
% Trucks	0.0%	0.0%	0.0%	0.0%	0.0%	0.0%	0.0%	0.0%	0.0%	0.0%	0.0%	0.0%	0.0%	0.0%	0.0%	0.0%	0.0%	0.0%	0.0%	0.0%	0.0%	0.0%	0.0%
Buses	0	0	0	0	0	0	0	0	4	0	0	4	0	0	0	0	0	0	0	0	0	0	8
% Buses	0.0%	0.0%	0.0%	0.0%	0.0%	0.0%	0.0%	0.0%	2.6%	0.0%	0.0%	0.0%	0.0%	0.0%	0.0%	0.0%	0.0%	0.0%	0.0%	0.0%	0.0%	0.0%	1.9%
Pedestrians	0	0	0	0	0	8	5	0	0	0	0	1	3	0	0	0	0	0	0	1	0	0	4
% Pedestrians	0.0%	0.0%	0.0%	0.0%	0.0%	100.0%	100.0%	0.0%	0.0%	0.0%	0.0%	0.0%	50.0%	100.0%	0.0%	0.0%	0.0%	0.0%	0.0%	0.0%	100.0%	100.0%	0.0%
Bicycles on Crosswalk	0	0	0	0	0	0	0	0	0	0	0	1	0	0	0	0	0	0	0	0	0	0	0
% Bicycles on Crosswalk	0.0%	0.0%	0.0%	0.0%	0.0%	0.0%	0.0%	0.0%	0.0%	0.0%	0.0%	0.0%	50.0%	0.0%	0.0%	0.0%	0.0%	0.0%	0.0%	0.0%	0.0%	0.0%	0.0%

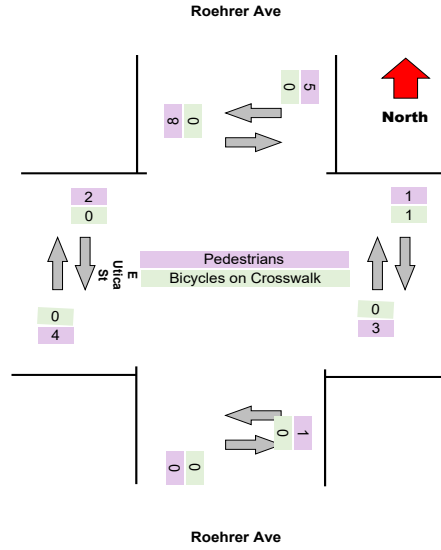
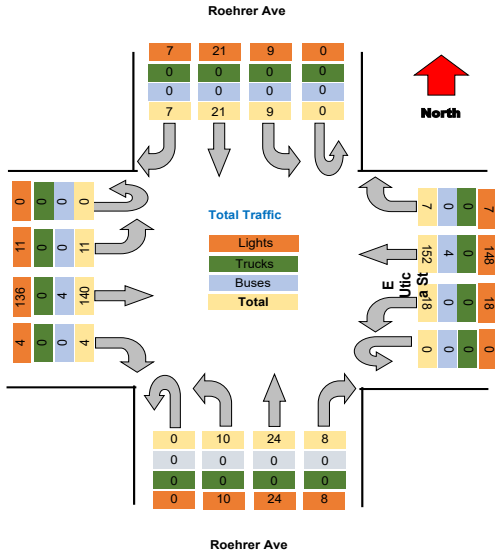



Project : VBH Malta NY  
 Site : Site 4  
 Location : 42.948550, -73.790036  
 Survey Date : 2021-04-28, Wednesday

**Turning Movement Data Plot**

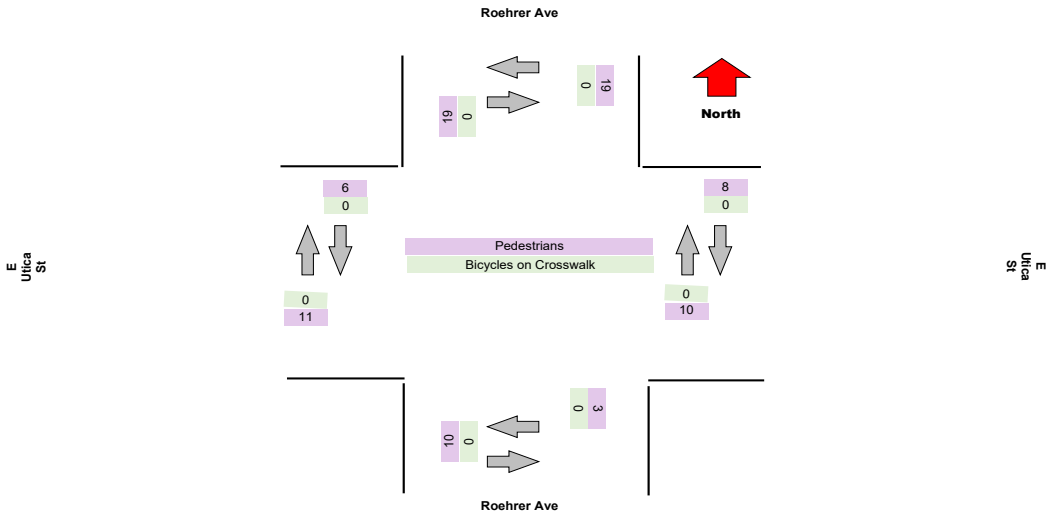
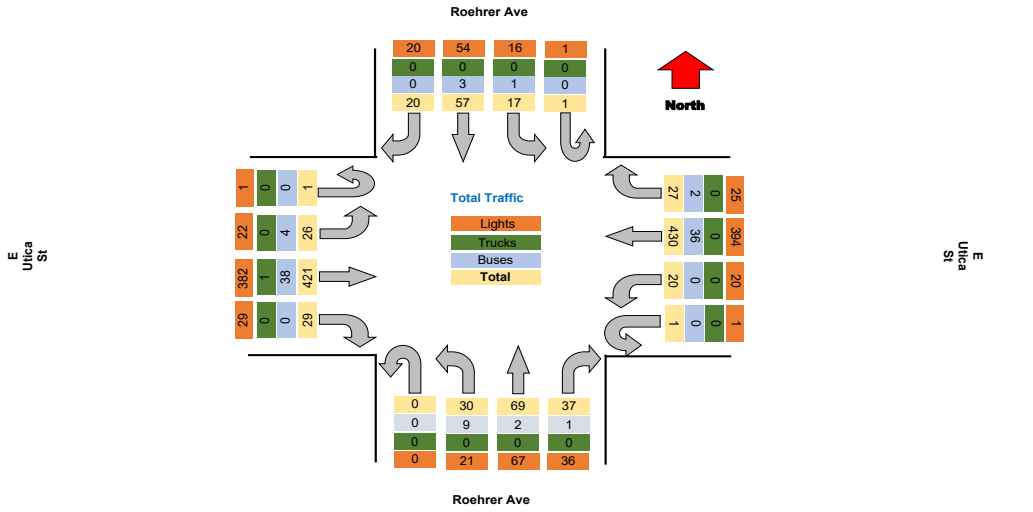

Project : VBH Malta NY  
Site : Site 4  
Location : 42.948550, -73.790036

TSTData.com

Survey Date : 2021-04-28, Wednesday

### Turning Movement Peak Hour Data (AM)

7:30:00 AM

Leg Direction	Roehrer Ave Southbound						E Ulrica St Westbound						Roehrer Ave Northbound						E Ulrica St Eastbound						Total					
	Right	Thru	Left	U-Turn	App Total	Peds CW	Peds CCW	Right	Thru	Left	U-Turn	App Total	Peds CW	Peds CCW	Right	Thru	Left	U-Turn	App Total	Peds CW	Peds CCW	Right	Thru	Left		U-Turn	App Total	Peds CW	Peds CCW	
7:30:00 AM	0	1	0	0	1	0	0	0	25	0	0	26	1	0	0	0	1	0	2	1	0	0	19	2	0	21	0	1	50	
7:45:00 AM	1	3	0	0	4	1	0	0	33	0	0	33	0	2	1	3	1	0	7	7	0	2	0	31	0	0	31	0	0	75
8:00:00 AM	1	2	0	0	3	1	0	1	33	1	0	35	0	0	2	4	0	0	6	6	0	0	0	28	1	0	29	0	0	73
8:15:00 AM	2	5	2	0	9	0	0	5	23	1	1	25	0	0	1	2	1	0	4	4	0	0	0	20	1	0	21	0	0	64
<b>Grand Total</b>	<b>4</b>	<b>11</b>	<b>2</b>	<b>0</b>	<b>17</b>	<b>2</b>	<b>0</b>	<b>6</b>	<b>114</b>	<b>2</b>	<b>1</b>	<b>124</b>	<b>1</b>	<b>2</b>	<b>4</b>	<b>9</b>	<b>3</b>	<b>0</b>	<b>19</b>	<b>1</b>	<b>2</b>	<b>0</b>	<b>88</b>	<b>4</b>	<b>0</b>	<b>102</b>	<b>3</b>	<b>1</b>	<b>282</b>	
% Approach	23.5%	64.7%	11.8%	0.0%	0.0%	0.0%	0.0%	4.8%	91.9%	1.6%	0.8%	0.0%	0.0%	0.0%	21.1%	47.4%	15.8%	0.0%	0.0%	0.0%	0.0%	0.0%	0.0%	96.1%	3.9%	0.0%	0.0%	0.0%	0.0%	0.0%
% Total	1.5%	4.2%	0.8%	0.0%	6.5%	0.0%	0.0%	2.3%	43.5%	0.8%	0.4%	47.3%	0.0%	0.0%	1.5%	3.4%	1.1%	0.0%	7.3%	0.0%	0.0%	0.0%	0.0%	37.4%	1.5%	0.0%	38.9%	0.0%	0.0%	0.0%
PHF	0.500	0.550	0.250	0.000	0.472	0.000	0.000	0.300	0.884	0.500	0.250	0.886	0.000	0.000	0.500	0.563	0.750	0.000	0.679	0.000	0.000	0.000	0.000	0.790	0.500	0.000	0.823	0.000	0.000	0.873
Lights	4	11	2	0	17	0	0	6	103	2	1	112	0	0	4	9	0	0	13	0	0	0	84	1	0	85	0	0	227	
% Lights	100.0%	100.0%	100.0%	0.0%	100.0%	0.0%	0.0%	100.0%	90.4%	100.0%	100.0%	90.3%	0.0%	0.0%	100.0%	100.0%	0.0%	0.0%	68.4%	0.0%	0.0%	0.0%	0.0%	85.7%	25.0%	0.0%	83.3%	0.0%	0.0%	86.6%
Trucks	0	0	0	0	0	0	0	0	0	0	0	0	0	0	0	0	0	0	0	0	0	0	0	0	0	0	0	0	0	0
% Trucks	0.0%	0.0%	0.0%	0.0%	0.0%	0.0%	0.0%	0.0%	0.0%	0.0%	0.0%	0.0%	0.0%	0.0%	0.0%	0.0%	0.0%	0.0%	0.0%	0.0%	0.0%	0.0%	0.0%	0.0%	0.0%	0.0%	0.0%	0.0%	0.0%	0.0%
Buses	0	0	0	0	0	0	0	0	11	0	0	11	0	0	0	0	3	0	3	0	0	0	0	14	3	0	17	0	0	31
% Buses	0.0%	0.0%	0.0%	0.0%	0.0%	0.0%	0.0%	0.0%	9.6%	0.0%	0.0%	0.0%	0.0%	0.0%	0.0%	0.0%	100.0%	0.0%	0.0%	0.0%	0.0%	0.0%	0.0%	14.3%	75.0%	0.0%	0.0%	0.0%	0.0%	11.8%
Pedestrians	0	0	0	0	0	2	1	0	0	0	0	0	1	2	0	0	0	0	0	1	2	0	0	0	0	0	0	1	0	
% Pedestrians	0.0%	0.0%	0.0%	0.0%	0.0%	100.0%	100.0%	0.0%	0.0%	0.0%	0.0%	0.0%	100.0%	100.0%	0.0%	0.0%	0.0%	0.0%	0.0%	0.0%	100.0%	100.0%	0.0%	0.0%	0.0%	0.0%	0.0%	100.0%	0.0%	0.0%
Bicycles on Crosswalk	0	0	0	0	0	0	0	0	0	0	0	0	0	0	0	0	0	0	0	0	0	0	0	0	0	0	0	0	0	
% Bicycles on Crosswalk	0.0%	0.0%	0.0%	0.0%	0.0%	0.0%	0.0%	0.0%	0.0%	0.0%	0.0%	0.0%	0.0%	0.0%	0.0%	0.0%	0.0%	0.0%	0.0%	0.0%	0.0%	0.0%	0.0%	0.0%	0.0%	0.0%	0.0%	0.0%	0.0%	0.0%

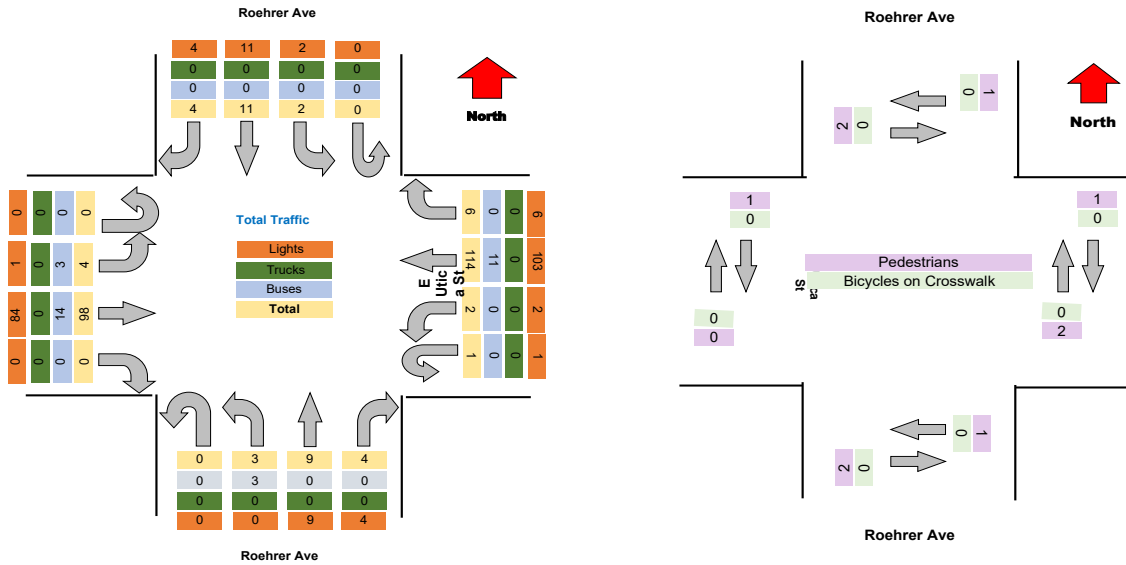

**Turning Movement Peak Hour Data (PM)**

4:15:00 PM

Leg Direction	Roehrer Ave				E Ulica St				Roehrer Ave				E Ulica St				Total												
	Southbound				Westbound				Northbound				Eastbound																
Start Time	Right	Thru	Left	U-Turn	App Total	Peds CW	Peds CCW	Right	Thru	Left	U-Turn	App Total	Peds CW	Peds CCW	Right	Thru	Left	U-Turn	App Total	Peds CW	Peds CCW								
4:15:00 PM	2	5	3	0	10	1	3	6	37	3	0	46	0	1	4	5	4	0	13	0	0	6	43	3	0	52	0	2	121
4:30:00 PM	2	5	1	0	8	3	0	2	34	3	0	39	0	1	6	5	4	0	15	0	1	1	33	2	0	36	0	1	98
4:45:00 PM	1	9	1	0	11	2	1	2	34	0	0	36	0	0	3	9	3	0	15	0	1	1	28	2	0	31	0	0	93
5:00:00 PM	2	7	4	0	13	2	4	4	32	0	0	36	0	0	2	4	3	0	9	0	1	0	38	3	1	42	0	1	100
<b>Grand Total</b>	<b>7</b>	<b>28</b>	<b>9</b>	<b>0</b>	<b>42</b>	<b>6</b>	<b>8</b>	<b>14</b>	<b>137</b>	<b>6</b>	<b>0</b>	<b>157</b>	<b>0</b>	<b>2</b>	<b>15</b>	<b>23</b>	<b>14</b>	<b>0</b>	<b>52</b>	<b>0</b>	<b>2</b>	<b>8</b>	<b>142</b>	<b>10</b>	<b>1</b>	<b>161</b>	<b>3</b>	<b>4</b>	<b>412</b>
<b>% Approach</b>	16.7%	61.0%	21.4%	0.0%	<b>0.0%</b>	0.0%	0.0%	8.9%	87.3%	3.8%	0.0%	<b>0.0%</b>	0.0%	0.0%	28.6%	44.2%	26.9%	0.0%	<b>0.0%</b>	0.0%	0.0%	5.0%	85.2%	6.2%	0.6%	<b>0.0%</b>	0.0%	0.0%	0.0%
<b>% Total</b>	1.7%	6.3%	2.2%	0.0%	<b>10.2%</b>	0.0%	0.0%	3.4%	33.3%	1.5%	0.0%	<b>38.1%</b>	0.0%	0.0%	3.6%	5.6%	3.4%	0.0%	<b>12.6%</b>	0.0%	0.0%	1.9%	34.5%	2.4%	0.2%	<b>38.1%</b>	0.0%	0.0%	0.0%
<b>PHF</b>	0.875	0.722	0.563	0.000	<b>0.808</b>	0.000	0.000	0.583	0.926	0.500	0.000	<b>0.853</b>	0.000	0.000	0.625	0.639	0.875	0.000	<b>0.867</b>	0.000	0.000	0.333	0.826	0.833	0.250	<b>0.774</b>	0.000	0.000	<b>0.891</b>
<b>Lights</b>	7	23	9	0	<b>39</b>	0	0	12	127	6	0	<b>145</b>	0	0	14	23	9	0	<b>46</b>	0	0	8	134	10	1	<b>153</b>	0	0	<b>383</b>
<b>% Lights</b>	100.0%	88.5%	100.0%	0.0%	<b>92.9%</b>	0.0%	0.0%	85.7%	92.7%	100.0%	0.0%	<b>92.4%</b>	0.0%	0.0%	83.3%	100.0%	64.3%	0.0%	<b>88.5%</b>	0.0%	0.0%	100.0%	94.4%	100.0%	100.0%	<b>95.0%</b>	0.0%	0.0%	<b>93.0%</b>
<b>Trucks</b>	0	0	0	0	<b>0</b>	0	0	0	0	0	0	<b>0</b>	0	0	0	0	0	0	<b>0</b>	0	0	0	1	0	0	<b>1</b>	0	0	<b>1</b>
<b>% Trucks</b>	0.0%	0.0%	0.0%	0.0%	<b>0.0%</b>	0.0%	0.0%	0.0%	0.0%	0.0%	0.0%	<b>0.0%</b>	0.0%	0.0%	0.0%	0.0%	0.0%	0.0%	<b>0.0%</b>	0.0%	0.0%	0.0%	0.7%	0.0%	0.0%	<b>0.6%</b>	0.0%	0.0%	<b>0.2%</b>
<b>Buses</b>	0	3	0	0	<b>3</b>	0	0	2	10	0	0	<b>12</b>	0	0	1	0	5	0	<b>6</b>	0	0	0	7	0	0	<b>7</b>	0	0	<b>28</b>
<b>% Buses</b>	0.0%	11.5%	0.0%	0.0%	<b>0.0%</b>	0.0%	0.0%	14.3%	7.3%	0.0%	0.0%	<b>0.0%</b>	0.0%	0.0%	6.7%	0.0%	35.7%	0.0%	<b>0.0%</b>	0.0%	0.0%	0.0%	4.9%	0.0%	0.0%	<b>0.0%</b>	0.0%	0.0%	<b>6.8%</b>
<b>Pedestrians</b>	0	0	0	0	<b>0</b>	8	6	0	0	0	0	<b>0</b>	2	0	0	0	0	0	<b>0</b>	3	0	0	0	0	0	<b>0</b>	0	4	<b>0</b>
<b>% Pedestrians</b>	0.0%	0.0%	0.0%	0.0%	<b>0.0%</b>	100.0%	100.0%	0.0%	0.0%	0.0%	0.0%	<b>0.0%</b>	0.0%	100.0%	0.0%	0.0%	0.0%	0.0%	<b>0.0%</b>	0.0%	0.0%	0.0%	0.0%	0.0%	0.0%	<b>0.0%</b>	0.0%	100.0%	<b>0.0%</b>
<b>Bicycles on Crosswalk</b>	0	0	0	0	<b>0</b>	0	0	0	0	0	0	<b>0</b>	0	0	0	0	0	0	<b>0</b>	0	0	0	0	0	0	<b>0</b>	0	0	<b>0</b>
<b>% Bicycles on Crosswalk</b>	0.0%	0.0%	0.0%	0.0%	<b>0.0%</b>	0.0%	0.0%	0.0%	0.0%	0.0%	0.0%	<b>0.0%</b>	0.0%	0.0%	0.0%	0.0%	0.0%	0.0%	<b>0.0%</b>	0.0%	0.0%	0.0%	0.0%	0.0%	0.0%	<b>0.0%</b>	0.0%	0.0%	<b>0.0%</b>

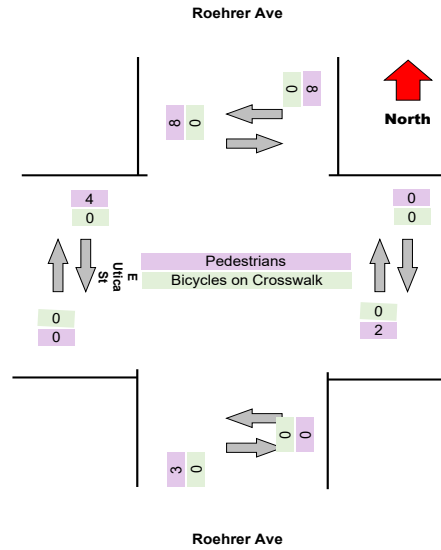
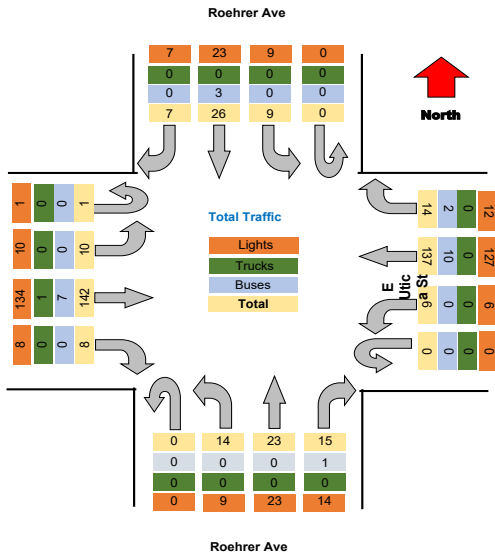





**Turning Movement Data Plot**

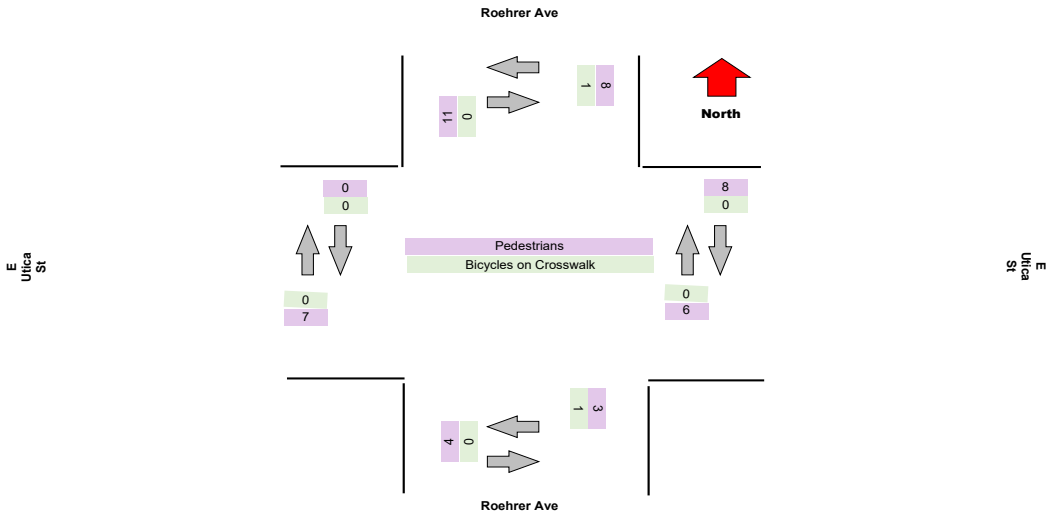
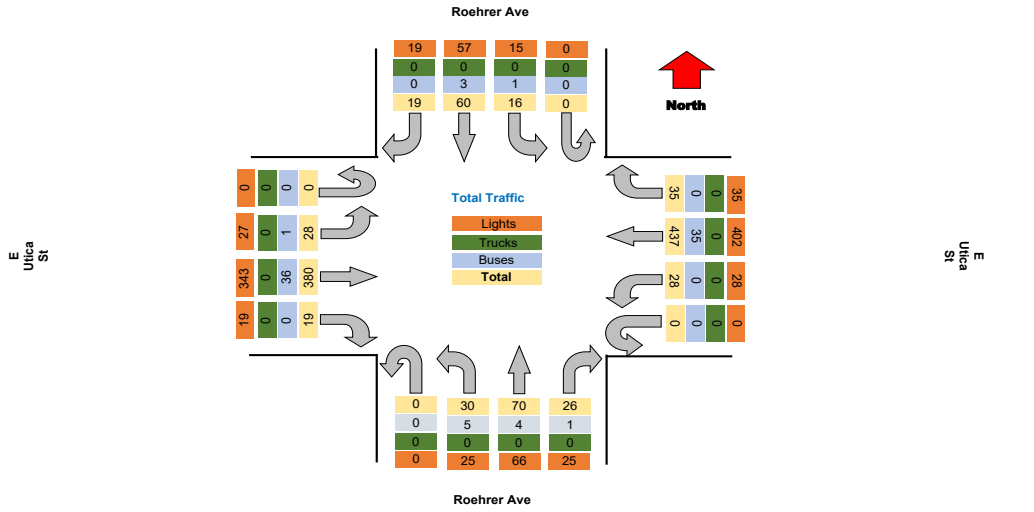

**Turning Movement Peak Hour Data (AM)**

7:30:00 AM

Leg Direction	Roehrer Ave				E Ulrica St				Roehrer Ave				E Ulrica St				Total					
	Southbound				Westbound				Northbound				Eastbound									
Start Time	Right	Thru	Left	U-Turn	App Total	Peds CW	Peds CCW	Right	Thru	Left	U-Turn	App Total	Peds CW	Peds CCW	Right	Thru	Left	U-Turn	App Total	Peds CW	Peds CCW	
7:30:00 AM	0	1	0	0	1	0	0	0	29	1	0	30	0	0	3	1	1	0	5	0	0	55
7:45:00 AM	1	2	0	0	3	0	0	1	35	1	0	37	0	0	2	2	1	0	5	0	1	68
8:00:00 AM	0	3	0	0	3	0	0	3	29	3	0	35	0	0	0	3	0	0	3	0	0	68
8:15:00 AM	0	2	0	0	2	0	0	3	22	0	0	25	0	0	0	2	0	0	2	0	0	46
<b>Grand Total</b>	<b>1</b>	<b>8</b>	<b>0</b>	<b>0</b>	<b>9</b>	<b>0</b>	<b>0</b>	<b>7</b>	<b>115</b>	<b>5</b>	<b>0</b>	<b>128</b>	<b>0</b>	<b>0</b>	<b>5</b>	<b>3</b>	<b>2</b>	<b>0</b>	<b>15</b>	<b>0</b>	<b>1</b>	<b>237</b>
% Approach	11.1%	88.9%	0.0%	0.0%	0.0%	0.0%	0.0%	5.5%	89.8%	3.9%	0.0%	0.0%	0.0%	0.0%	33.3%	53.3%	13.3%	0.0%	0.0%	0.0%	0.0%	0.0%
% Total	0.4%	3.4%	0.0%	0.0%	3.8%	0.0%	0.0%	3.0%	48.5%	2.1%	0.0%	54.0%	0.0%	0.0%	2.1%	3.4%	0.8%	0.0%	6.3%	0.0%	0.0%	0.0%
PHF	0.250	0.667	0.000	0.000	0.750	0.000	0.000	0.583	0.821	0.417	0.000	0.865	0.000	0.000	0.417	0.667	0.500	0.000	0.750	0.000	0.000	0.871
Lights	1	7	0	0	8	0	0	7	104	5	0	116	0	0	5	7	1	0	13	0	0	207
% Lights	100.0%	87.5%	0.0%	0.0%	88.9%	0.0%	0.0%	100.0%	90.4%	100.0%	0.0%	90.6%	0.0%	0.0%	100.0%	87.5%	50.0%	0.0%	86.7%	0.0%	0.0%	87.3%
Trucks	0	0	0	0	0	0	0	0	0	0	0	0	0	0	0	0	0	0	0	0	0	0
% Trucks	0.0%	0.0%	0.0%	0.0%	0.0%	0.0%	0.0%	0.0%	0.0%	0.0%	0.0%	0.0%	0.0%	0.0%	0.0%	0.0%	0.0%	0.0%	0.0%	0.0%	0.0%	0.0%
Buses	0	1	0	0	1	0	0	0	11	0	0	11	0	0	0	1	1	0	2	0	0	29
% Buses	0.0%	12.5%	0.0%	0.0%	0.0%	0.0%	0.0%	0.0%	9.6%	0.0%	0.0%	0.0%	0.0%	0.0%	0.0%	12.5%	50.0%	0.0%	0.0%	0.0%	0.0%	12.2%
Pedestrians	0	0	0	0	0	0	0	0	0	0	0	0	0	0	0	0	0	0	0	0	1	0
% Pedestrians	0.0%	0.0%	0.0%	0.0%	0.0%	0.0%	100.0%	0.0%	0.0%	0.0%	0.0%	0.0%	0.0%	0.0%	0.0%	0.0%	0.0%	0.0%	0.0%	0.0%	0.0%	0.0%
Bicycles on Crosswalk	0	0	0	0	0	0	0	0	0	0	0	0	0	0	0	0	0	0	0	0	0	0
% Bicycles on Crosswalk	0.0%	0.0%	0.0%	0.0%	0.0%	0.0%	0.0%	0.0%	0.0%	0.0%	0.0%	0.0%	0.0%	0.0%	0.0%	0.0%	0.0%	0.0%	0.0%	0.0%	0.0%	0.0%

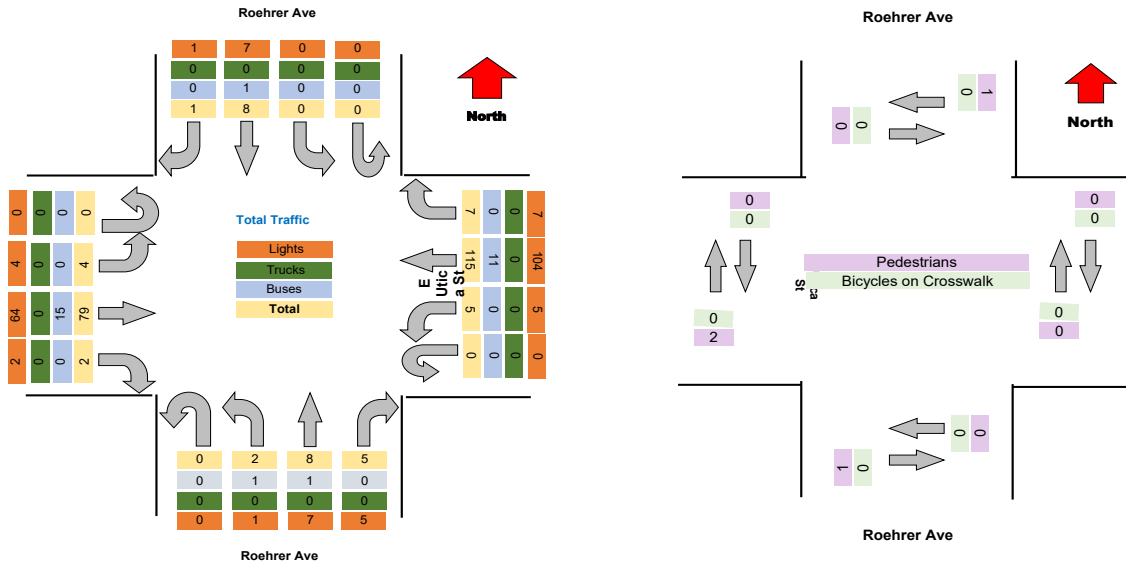

### Turning Movement Peak Hour Data (PM)

4:15:00 PM

Leg Direction	Roehrer Ave										E Ulica St										Total									
	Southbound					Westbound					Northbound					Eastbound														
	Right	Thru	Left	U-Turn	App Total	Peds CW	Peds CCW	Right	Thru	Left	U-Turn	App Total	Peds CW	Peds CCW	Right	Thru	Left	U-Turn	App Total	Peds CW		Peds CCW								
4:15:00 PM	1	3	4	0	8	1	0	0	37	5	0	42	0	2	3	16	1	0	20	0	0	2	36	3	0	41	1	0	111	
4:30:00 PM	2	12	2	0	16	6	0	3	27	2	0	32	3	0	3	10	3	0	16	2	1	1	1	37	2	0	40	0	0	104
4:45:00 PM	3	6	1	0	10	2	2	3	42	0	0	45	1	0	2	7	5	0	14	0	0	0	2	43	2	0	47	0	0	116
5:00:00 PM	2	7	3	0	12	0	0	7	39	2	0	39	2	1	2	8	4	0	14	0	0	0	1	35	1	0	37	3	0	102
<b>Grand Total</b>	<b>9</b>	<b>28</b>	<b>10</b>	<b>0</b>	<b>46</b>	<b>9</b>	<b>2</b>	<b>13</b>	<b>136</b>	<b>9</b>	<b>0</b>	<b>158</b>	<b>8</b>	<b>3</b>	<b>10</b>	<b>41</b>	<b>13</b>	<b>0</b>	<b>64</b>	<b>2</b>	<b>1</b>	<b>6</b>	<b>151</b>	<b>8</b>	<b>0</b>	<b>165</b>	<b>4</b>	<b>0</b>	<b>433</b>	
<b>% Approach</b>	17.4%	60.0%	21.7%	0.0%	0.0%	0.0%	0.0%	8.2%	86.1%	5.7%	0.0%	0.0%	0.0%	0.0%	15.6%	64.1%	20.3%	0.0%	0.0%	0.0%	0.0%	0.0%	3.6%	91.5%	4.8%	0.0%	0.0%	0.0%	0.0%	0.0%
<b>% Total</b>	1.8%	6.5%	2.3%	0.0%	10.6%	0.0%	0.0%	3.0%	31.4%	2.1%	0.0%	36.5%	0.0%	0.0%	2.3%	9.5%	3.0%	0.0%	14.8%	0.0%	0.0%	0.0%	1.4%	34.9%	1.8%	0.0%	38.1%	0.0%	0.0%	0.0%
<b>PHF</b>	0.667	0.583	0.625	0.000	0.719	0.000	0.000	0.464	0.810	0.450	0.000	0.878	0.000	0.000	0.833	0.641	0.650	0.000	0.800	0.000	0.000	0.000	0.750	0.878	0.667	0.000	0.878	0.000	0.000	0.933
<b>Lights</b>	8	26	10	0	44	0	0	13	127	9	0	149	0	0	10	39	9	0	58	0	0	0	6	145	8	0	159	0	0	410
<b>% Lights</b>	100.0%	92.9%	100.0%	0.0%	95.7%	0.0%	0.0%	100.0%	93.4%	100.0%	0.0%	94.3%	0.0%	0.0%	100.0%	95.1%	69.2%	0.0%	90.6%	0.0%	0.0%	0.0%	100.0%	96.0%	100.0%	0.0%	96.4%	0.0%	0.0%	94.7%
<b>Trucks</b>	0	0	0	0	0	0	0	0	0	0	0	0	0	0	0	0	0	0	0	0	0	0	0	0	0	0	0	0	0	0
<b>% Trucks</b>	0.0%	0.0%	0.0%	0.0%	0.0%	0.0%	0.0%	0.0%	0.0%	0.0%	0.0%	0.0%	0.0%	0.0%	0.0%	0.0%	0.0%	0.0%	0.0%	0.0%	0.0%	0.0%	0.0%	0.0%	0.0%	0.0%	0.0%	0.0%	0.0%	0.0%
<b>Buses</b>	0	2	0	0	2	0	0	0	9	0	0	9	0	0	0	2	4	0	6	0	0	0	0	5	0	0	5	0	0	22
<b>% Buses</b>	0.0%	7.1%	0.0%	0.0%	0.0%	0.0%	0.0%	0.0%	6.6%	0.0%	0.0%	0.0%	0.0%	0.0%	0.0%	4.9%	30.8%	0.0%	0.0%	0.0%	0.0%	0.0%	0.0%	3.3%	0.0%	0.0%	0.0%	0.0%	0.0%	5.1%
<b>Pedestrians</b>	0	0	0	0	0	9	3	0	0	0	0	0	6	3	0	0	0	0	2	1	0	0	0	0	0	0	4	0	0	
<b>% Pedestrians</b>	0.0%	0.0%	0.0%	0.0%	0.0%	100.0%	75.0%	0.0%	0.0%	0.0%	0.0%	0.0%	100.0%	100.0%	0.0%	0.0%	0.0%	0.0%	0.0%	100.0%	100.0%	0.0%	0.0%	0.0%	0.0%	0.0%	0.0%	0.0%	0.0%	0.0%
<b>Bicycles on Crosswalk</b>	0	0	0	0	0	0	1	0	0	0	0	0	0	0	0	0	0	0	0	0	0	0	0	0	0	0	0	0	0	
<b>% Bicycles on Crosswalk</b>	0.0%	0.0%	0.0%	0.0%	0.0%	0.0%	25.0%	0.0%	0.0%	0.0%	0.0%	0.0%	0.0%	0.0%	0.0%	0.0%	0.0%	0.0%	0.0%	0.0%	0.0%	0.0%	0.0%	0.0%	0.0%	0.0%	0.0%	0.0%	0.0%	

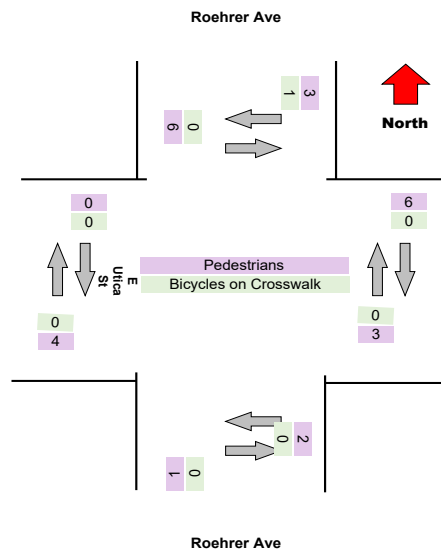
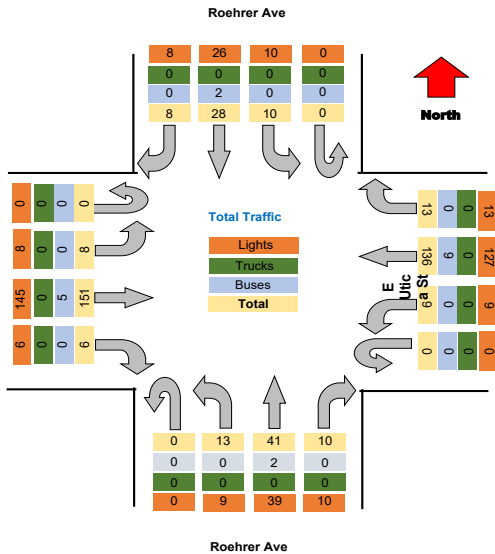



Project : VBH Malta NY  
 Site : Site 4  
 Location : 42.948550, -73.790036  
 Survey Date : 2021-04-28, Wednesday

### Turning Movement Data Plot

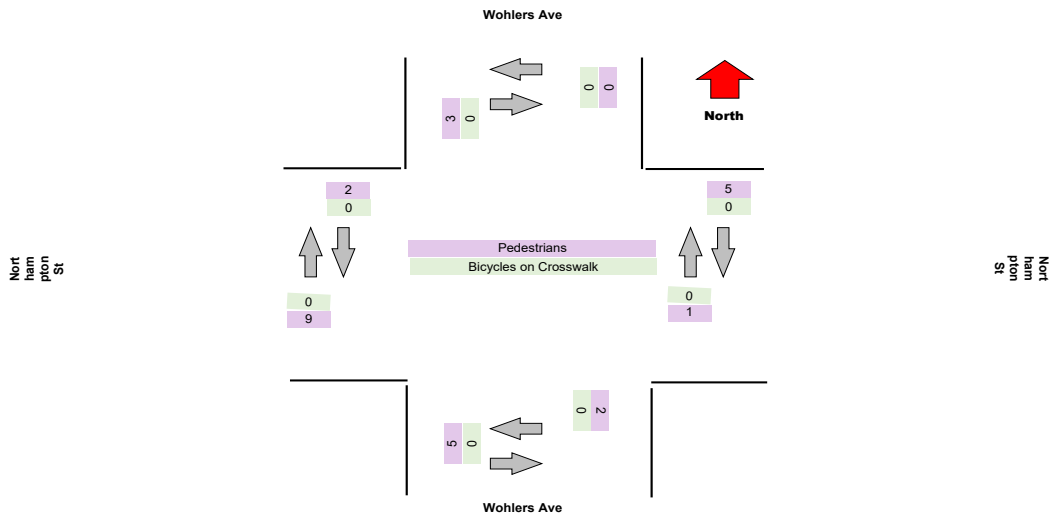
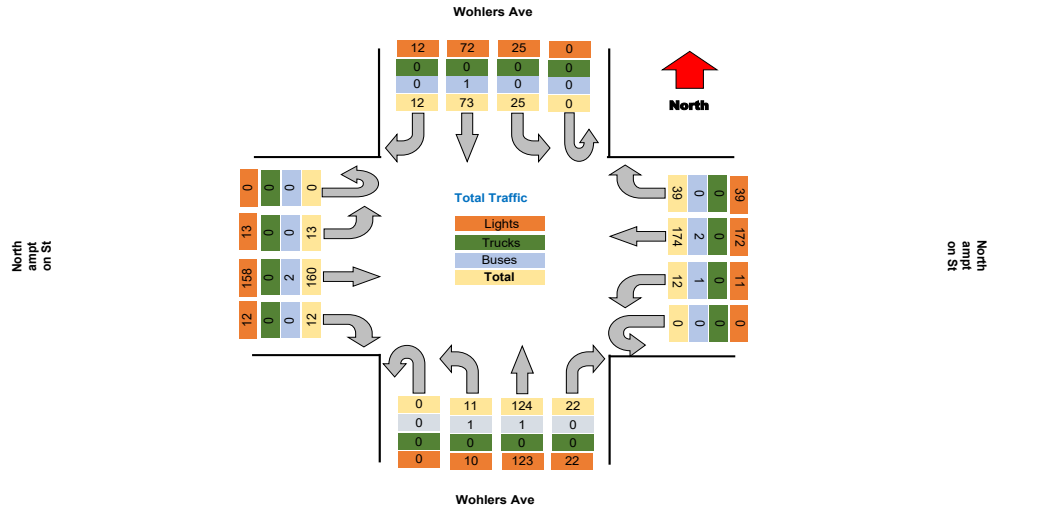

Project : VBH Malta NY  
Site : Site 4  
Location : 42.948550, -73.790036

TSTData.com

Survey Date : 2021-04-28, Wednesday

### Turning Movement Peak Hour Data (AM)

7:30:00 AM

Leg Direction	Wohlers Ave						Northampton St						Wohlers Ave						Northampton St						Total					
	Southbound			Northbound			Westbound			Eastbound			Northbound			Eastbound														
Start Time	Right	Thru	Left	U-Turn	App Total	Peds CW	Peds CCW	Right	Thru	Left	U-Turn	App Total	Peds CW	Peds CCW	Right	Thru	Left	U-Turn	App Total	Peds CW	Peds CCW	Right	Thru	Left	U-Turn	App Total	Peds CW	Peds CCW		
7:30:00 AM	0	1	1	0	2	0	0	3	9	0	0	12	0	0	0	2	0	0	2	1	0	0	0	8	0	0	0	0	24	
7:45:00 AM	1	3	0	0	4	0	0	0	10	0	0	10	0	0	1	6	0	0	7	0	0	0	1	9	0	0	10	0	31	
8:00:00 AM	0	3	0	0	3	0	0	1	13	0	0	14	0	0	1	2	2	0	5	0	0	0	5	0	0	0	0	27		
8:15:00 AM	0	5	0	0	5	0	0	0	19	1	0	20	0	0	0	3	2	0	5	1	0	0	1	10	1	0	12	0	42	
Grand Total	1	12	1	0	14	0	0	4	51	1	0	56	0	0	2	13	4	0	19	2	0	0	2	32	1	0	35	0	124	
% Approach	7.1%	85.7%	7.1%	0.0%	0.0%	0.0%	0.0%	7.1%	91.1%	1.8%	0.0%	0.0%	0.0%	0.0%	10.5%	68.4%	21.1%	0.0%	0.0%	0.0%	0.0%	0.0%	5.7%	91.4%	2.9%	0.0%	0.0%	0.0%	0.0%	
% Total	0.8%	9.7%	0.8%	0.0%	11.3%	0.0%	0.0%	3.2%	41.1%	0.8%	0.0%	45.2%	0.0%	0.0%	1.6%	10.5%	3.2%	0.0%	15.3%	0.0%	0.0%	0.0%	1.6%	25.8%	0.8%	0.0%	28.2%	0.0%	0.0%	
PHF	0.250	0.600	0.250	0.000	0.700	0.000	0.000	0.333	0.671	0.250	0.000	0.700	0.000	0.000	0.500	0.542	0.500	0.000	0.679	0.000	0.000	0.000	0.500	0.800	0.250	0.000	0.729	0.000	0.000	0.738
Lights	1	12	1	0	14	0	0	4	51	1	0	56	0	0	2	13	4	0	19	0	0	0	2	31	1	0	34	0	123	
% Lights	100.0%	100.0%	100.0%	0.0%	100.0%	0.0%	0.0%	100.0%	100.0%	100.0%	0.0%	100.0%	0.0%	0.0%	100.0%	100.0%	100.0%	0.0%	100.0%	0.0%	0.0%	0.0%	100.0%	96.9%	100.0%	0.0%	97.1%	0.0%	0.0%	99.2%
Trucks	0	0	0	0	0	0	0	0	0	0	0	0	0	0	0	0	0	0	0	0	0	0	0	0	0	0	0	0	0	0
% Trucks	0.0%	0.0%	0.0%	0.0%	0.0%	0.0%	0.0%	0.0%	0.0%	0.0%	0.0%	0.0%	0.0%	0.0%	0.0%	0.0%	0.0%	0.0%	0.0%	0.0%	0.0%	0.0%	0.0%	0.0%	0.0%	0.0%	0.0%	0.0%	0.0%	0.0%
Buses	0	0	0	0	0	0	0	0	0	0	0	0	0	0	0	0	0	0	0	0	0	0	1	0	0	0	1	0	1	
% Buses	0.0%	0.0%	0.0%	0.0%	0.0%	0.0%	0.0%	0.0%	0.0%	0.0%	0.0%	0.0%	0.0%	0.0%	0.0%	0.0%	0.0%	0.0%	0.0%	0.0%	0.0%	0.0%	3.1%	0.0%	0.0%	0.0%	0.0%	0.0%	0.8%	
Pedestrians	0	0	0	0	0	0	0	0	0	0	0	0	0	0	0	0	0	0	2	0	0	0	0	0	0	0	0	0	0	
% Pedestrians	0.0%	0.0%	0.0%	0.0%	0.0%	0.0%	0.0%	0.0%	0.0%	0.0%	0.0%	0.0%	0.0%	0.0%	0.0%	0.0%	0.0%	0.0%	0.0%	0.0%	0.0%	0.0%	0.0%	0.0%	0.0%	0.0%	0.0%	0.0%	0.0%	
Bicycles on Crosswalk	0	0	0	0	0	0	0	0	0	0	0	0	0	0	0	0	0	0	0	0	0	0	0	0	0	0	0	0	0	
% Bicycles on Crosswalk	0.0%	0.0%	0.0%	0.0%	0.0%	0.0%	0.0%	0.0%	0.0%	0.0%	0.0%	0.0%	0.0%	0.0%	0.0%	0.0%	0.0%	0.0%	0.0%	0.0%	0.0%	0.0%	0.0%	0.0%	0.0%	0.0%	0.0%	0.0%	0.0%	

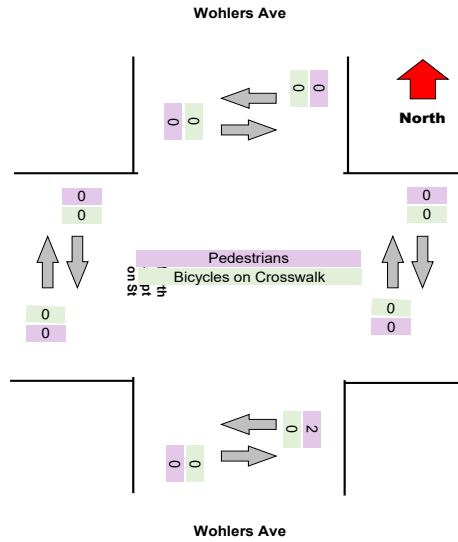
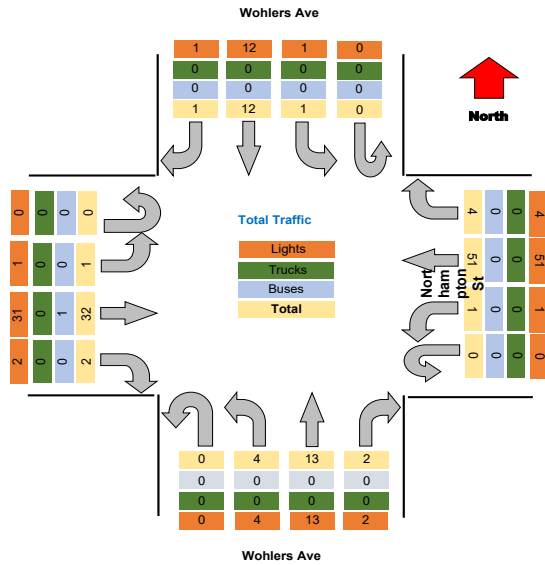

**Turning Movement Peak Hour Data (PM)**

4:15:00 PM

Leg Direction	Wohlers Ave										Northampton St										Wohlers Ave										Northampton St										Total
	Southbound					Westbound					Northbound					Eastbound					Northbound					Eastbound															
	Right	Thru	Left	U-Turn	App Total	Right	Thru	Left	U-Turn	App Total	Right	Thru	Left	U-Turn	App Total	Right	Thru	Left	U-Turn	App Total	Right	Thru	Left	U-Turn	App Total	Right	Thru	Left	U-Turn	App Total	Right	Thru	Left	U-Turn	App Total						
4:15:00 PM	3	5	2	0	10	1	0	0	0	1	3	12	1	0	16	1	0	0	0	1	3	10	0	0	13	0	0	0	0	0	2	14	3	0	19	0	0	0	0	0	58
4:30:00 PM	0	5	2	0	7	0	0	0	0	0	6	13	2	0	21	0	0	0	0	0	1	14	1	0	16	0	0	0	0	0	0	6	1	0	7	1	1	0	0	2	66
4:45:00 PM	1	4	2	0	7	0	0	0	0	0	1	12	2	0	15	0	0	0	0	0	2	10	3	0	15	0	0	0	0	0	4	23	2	0	29	3	2	0	0	5	80
5:00:00 PM	2	10	3	0	15	0	0	0	0	0	1	20	3	0	24	0	0	0	0	0	2	15	3	0	20	0	0	0	0	0	0	19	2	0	21	1	0	0	0	1	80
Grand Total	6	24	9	0	39	0	0	0	0	0	11	57	6	0	75	0	0	0	0	0	8	49	7	0	64	0	0	0	0	0	6	62	8	0	76	5	3	0	0	8	255
% Approach	15.4%	61.5%	23.1%	0.0%	0.0%	0.0%	0.0%	0.0%	0.0%	0.0%	14.5%	75.0%	10.5%	0.0%	0.0%	0.0%	0.0%	0.0%	0.0%	0.0%	12.5%	76.6%	10.9%	0.0%	0.0%	0.0%	0.0%	0.0%	0.0%	0.0%	7.9%	81.6%	10.5%	0.0%	0.0%	0.0%	0.0%	0.0%	0.0%	0.0%	
% Total	2.4%	9.4%	3.5%	0.0%	15.3%	0.0%	0.0%	0.0%	0.0%	0.0%	4.3%	22.4%	3.1%	0.0%	29.8%	0.0%	0.0%	0.0%	0.0%	0.0%	3.1%	19.2%	2.7%	0.0%	25.1%	0.0%	0.0%	0.0%	0.0%	0.0%	2.4%	24.3%	3.1%	0.0%	29.8%	0.0%	0.0%	0.0%	0.0%	0.0%	
PHF	0.500	0.600	0.750	0.000	0.650	0.000	0.000	0.000	0.000	0.000	0.458	0.713	0.667	0.000	0.792	0.000	0.000	0.000	0.000	0.000	0.667	0.817	0.583	0.000	0.800	0.000	0.000	0.000	0.000	0.000	0.375	0.674	0.667	0.000	0.655	0.000	0.000	0.000	0.000	0.000	0.787
Lights	6	24	9	0	39	0	0	0	0	0	11	56	7	0	74	0	0	0	0	0	8	49	7	0	63	0	0	0	0	0	6	61	8	0	75	0	0	0	0	0	251
% Lights	100.0%	100.0%	100.0%	0.0%	100.0%	0.0%	0.0%	0.0%	0.0%	0.0%	100.0%	98.2%	87.5%	0.0%	97.4%	0.0%	0.0%	0.0%	0.0%	0.0%	100.0%	100.0%	85.7%	0.0%	98.4%	0.0%	0.0%	0.0%	0.0%	0.0%	100.0%	98.4%	100.0%	0.0%	98.7%	0.0%	0.0%	0.0%	0.0%	0.0%	
Trucks	0	0	0	0	0	0	0	0	0	0	0	0	0	0	0	0	0	0	0	0	0	0	0	0	0	0	0	0	0	0	0	0	0	0	0	0	0	0	0	0	0
% Trucks	0.0%	0.0%	0.0%	0.0%	0.0%	0.0%	0.0%	0.0%	0.0%	0.0%	0.0%	0.0%	0.0%	0.0%	0.0%	0.0%	0.0%	0.0%	0.0%	0.0%	0.0%	0.0%	0.0%	0.0%	0.0%	0.0%	0.0%	0.0%	0.0%	0.0%	0.0%	0.0%	0.0%	0.0%	0.0%	0.0%	0.0%	0.0%	0.0%	0.0%	
Buses	0	0	0	0	0	0	0	0	0	0	0	1	1	0	2	0	0	0	0	0	0	0	1	0	1	0	0	0	0	0	0	1	0	0	1	0	0	0	0	0	4
% Buses	0.0%	0.0%	0.0%	0.0%	0.0%	0.0%	0.0%	0.0%	0.0%	0.0%	0.0%	1.8%	12.5%	0.0%	0.0%	0.0%	0.0%	14.3%	0.0%	0.0%	0.0%	0.0%	14.3%	0.0%	0.0%	0.0%	1.8%	0.0%	0.0%	0.0%	0.0%	1.6%	0.0%	0.0%	0.0%	0.0%	0.0%	0.0%	0.0%	0.0%	
Pedestrians	0	0	0	0	0	0	0	0	0	0	0	0	0	0	0	0	0	0	0	0	0	0	0	0	0	0	0	0	0	0	0	0	0	0	0	5	2	0	0	7	
% Pedestrians	0.0%	0.0%	0.0%	0.0%	0.0%	0.0%	0.0%	0.0%	0.0%	0.0%	0.0%	0.0%	0.0%	0.0%	0.0%	0.0%	0.0%	0.0%	0.0%	0.0%	0.0%	0.0%	0.0%	0.0%	0.0%	0.0%	0.0%	0.0%	0.0%	0.0%	0.0%	0.0%	0.0%	0.0%	0.0%	100.0%	100.0%	0.0%	0.0%	0.0%	
Bicycles on Crosswalk	0	0	0	0	0	0	0	0	0	0	0	0	0	0	0	0	0	0	0	0	0	0	0	0	0	0	0	0	0	0	0	0	0	0	0	0	0	0	0	0	0
% Bicycles on Crosswalk	0.0%	0.0%	0.0%	0.0%	0.0%	0.0%	0.0%	0.0%	0.0%	0.0%	0.0%	0.0%	0.0%	0.0%	0.0%	0.0%	0.0%	0.0%	0.0%	0.0%	0.0%	0.0%	0.0%	0.0%	0.0%	0.0%	0.0%	0.0%	0.0%	0.0%	0.0%	0.0%	0.0%	0.0%	0.0%	0.0%	0.0%	0.0%	0.0%	0.0%	

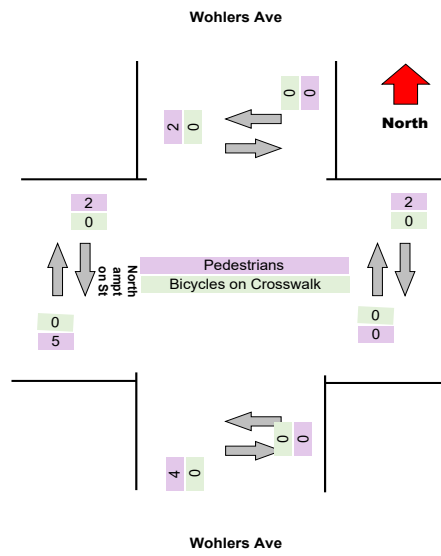
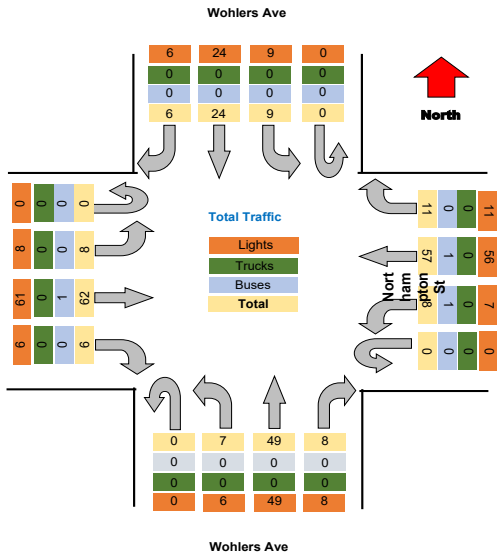





Project : VBH Malta NY  
 Site : Site 4  
 Location : 42.948550, -73.790036  
 Survey Date : 2021-04-28, Wednesday

### Turning Movement Data Plot

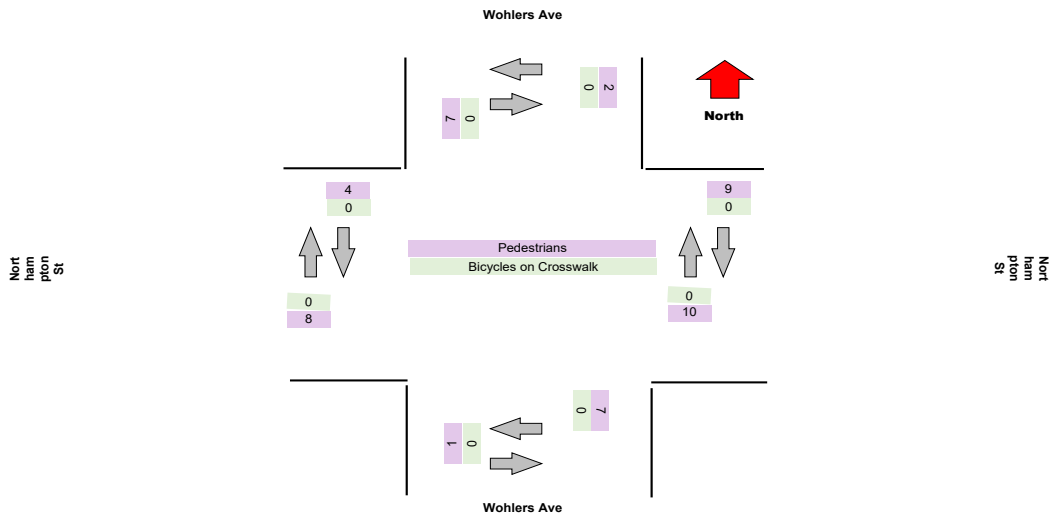
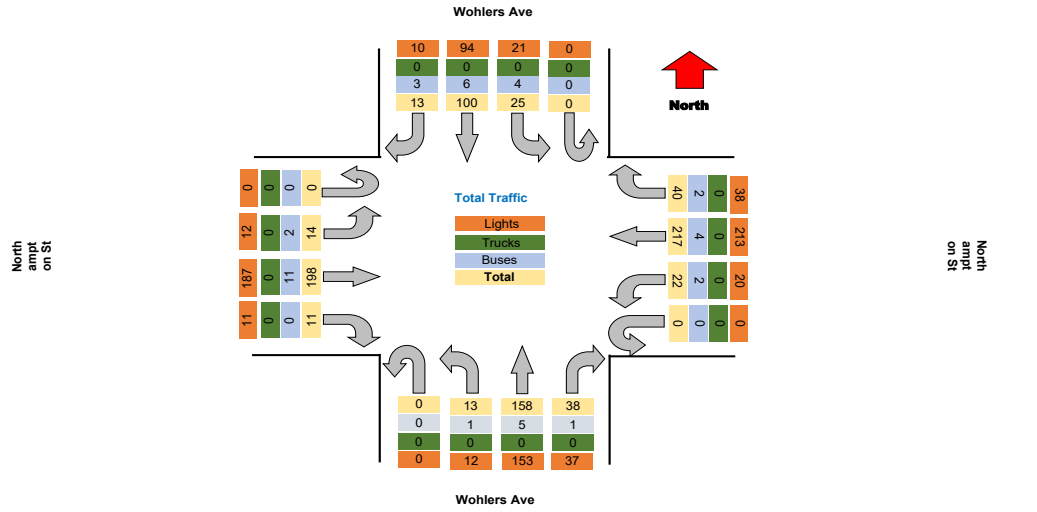

### Turning Movement Peak Hour Data (AM)

7:30:00 AM

Leg Direction	Wohlers Ave						Northampton St						Wohlers Ave						Northampton St						Total			
	Southbound			Northbound			Westbound			Eastbound			Northbound			Eastbound												
Start Time	Right	Thru	Left	U-Turn	App Total	Peds CW	Peds CCW	Right	Thru	Left	U-Turn	App Total	Peds CW	Peds CCW	Right	Thru	Left	U-Turn	App Total	Peds CW	Peds CCW	Right	Thru	Left	U-Turn	App Total	Peds CW	Peds CCW
7:30:00 AM	2	3	0	0	5	1	1	1	11	1	0	14	0	0	1	9	0	0	10	0	1	1	7	1	0	9	0	2
7:45:00 AM	1	8	3	0	12	1	0	1	18	0	0	19	0	0	3	5	0	0	8	0	0	0	16	1	0	17	2	1
8:00:00 AM	0	4	4	0	8	0	0	0	13	1	0	14	0	0	2	5	0	0	7	0	0	0	12	1	0	13	0	0
8:15:00 AM	1	6	1	0	8	0	0	2	20	1	0	23	0	0	3	4	3	0	10	1	0	0	7	1	0	8	0	0
<b>Grand Total</b>	<b>4</b>	<b>21</b>	<b>8</b>	<b>0</b>	<b>33</b>	<b>2</b>	<b>1</b>	<b>4</b>	<b>62</b>	<b>3</b>	<b>0</b>	<b>70</b>	<b>0</b>	<b>0</b>	<b>9</b>	<b>23</b>	<b>3</b>	<b>0</b>	<b>35</b>	<b>1</b>	<b>1</b>	<b>1</b>	<b>42</b>	<b>4</b>	<b>0</b>	<b>47</b>	<b>2</b>	<b>3</b>
% Approach	12.1%	63.6%	24.2%	0.0%	0.0%	0.0%	0.0%	5.7%	88.6%	4.3%	0.0%	0.0%	0.0%	0.0%	25.7%	65.7%	8.6%	0.0%	0.0%	0.0%	0.0%	2.1%	89.4%	8.5%	0.0%	0.0%	0.0%	0.0%
% Total	2.2%	11.4%	4.3%	0.0%	17.8%	0.0%	0.0%	2.2%	33.5%	1.6%	0.0%	37.8%	0.0%	0.0%	4.9%	12.4%	1.6%	0.0%	18.9%	0.0%	0.0%	0.5%	22.7%	2.2%	0.0%	25.4%	0.0%	0.0%
PHF	0.500	0.656	0.500	0.000	0.688	0.000	0.000	0.500	0.775	0.750	0.000	0.761	0.000	0.000	0.750	0.639	0.250	0.000	0.875	0.000	0.000	0.250	0.656	1.000	0.000	0.691	0.000	0.000
Lights	2	20	6	0	28	0	0	4	62	2	0	68	0	0	9	21	3	0	33	0	0	1	38	2	0	41	0	0
% Lights	50.0%	95.2%	75.0%	0.0%	84.8%	0.0%	0.0%	100.0%	100.0%	66.7%	0.0%	97.1%	0.0%	0.0%	100.0%	91.3%	100.0%	0.0%	94.3%	0.0%	0.0%	100.0%	90.5%	50.0%	0.0%	87.2%	0.0%	0.0%
Trucks	0	0	0	0	0	0	0	0	0	0	0	0	0	0	0	0	0	0	0	0	0	0	0	0	0	0	0	0
% Trucks	0.0%	0.0%	0.0%	0.0%	0.0%	0.0%	0.0%	0.0%	0.0%	0.0%	0.0%	0.0%	0.0%	0.0%	0.0%	0.0%	0.0%	0.0%	0.0%	0.0%	0.0%	0.0%	0.0%	0.0%	0.0%	0.0%	0.0%	0.0%
Buses	2	1	2	0	5	0	0	0	0	1	0	1	0	0	0	2	0	0	2	0	0	0	4	2	0	6	0	0
% Buses	50.0%	4.8%	25.0%	0.0%	0.0%	0.0%	0.0%	0.0%	0.0%	33.3%	0.0%	0.0%	0.0%	0.0%	0.0%	8.7%	0.0%	0.0%	0.0%	0.0%	0.0%	0.0%	9.5%	50.0%	0.0%	0.0%	0.0%	0.0%
Pedestrians	0	0	0	0	0	2	1	0	0	0	0	0	0	0	0	1	1	0	0	0	0	0	0	0	0	0	2	3
% Pedestrians	0.0%	0.0%	0.0%	0.0%	0.0%	100.0%	100.0%	0.0%	0.0%	0.0%	0.0%	0.0%	0.0%	0.0%	0.0%	0.0%	0.0%	0.0%	0.0%	0.0%	0.0%	0.0%	0.0%	0.0%	0.0%	0.0%	100.0%	100.0%
Bicycles on Crosswalk	0	0	0	0	0	0	0	0	0	0	0	0	0	0	0	0	0	0	0	0	0	0	0	0	0	0	0	0
% Bicycles on Crosswalk	0.0%	0.0%	0.0%	0.0%	0.0%	0.0%	0.0%	0.0%	0.0%	0.0%	0.0%	0.0%	0.0%	0.0%	0.0%	0.0%	0.0%	0.0%	0.0%	0.0%	0.0%	0.0%	0.0%	0.0%	0.0%	0.0%	0.0%	0.0%

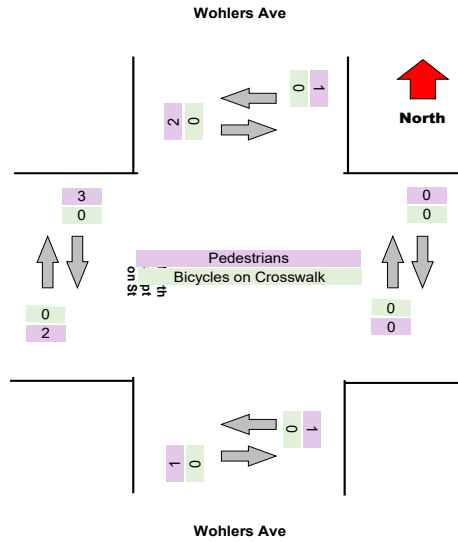
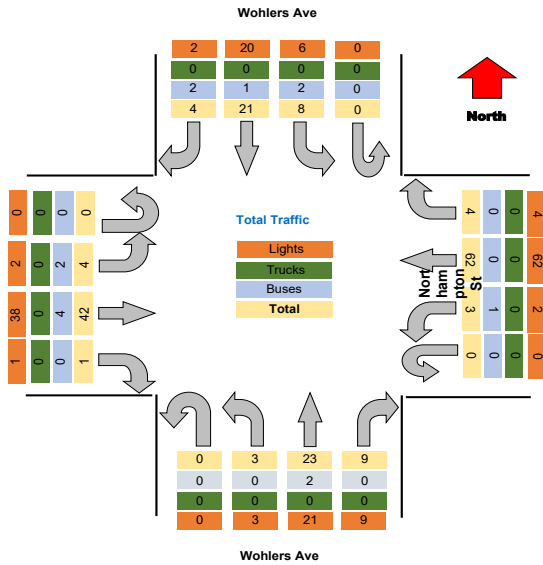

**Turning Movement Peak Hour Data (PM)**

4:15:00 PM

Leg Direction	Wohlers Ave										Northampton St										Total																									
	Southbound					Westbound					Northbound					Eastbound																														
	Right	Thru	Left	U-Turn	App Total	Right	Thru	Left	U-Turn	App Total	Right	Thru	Left	U-Turn	App Total	Right	Thru	Left	U-Turn	App Total																										
4:15:00 PM	3	7	1	0	11	0	0	0	0	0	1	18	3	0	22	0	0	0	0	0	1	12	1	0	14	2	0	0	0	2	1	19	1	0	21	0	0	0	0	0	68					
4:30:00 PM	0	13	4	0	17	2	0	0	0	2	6	15	2	0	23	0	0	0	0	0	4	10	0	0	14	0	0	0	0	0	0	18	3	0	21	0	1	0	0	1	75					
4:45:00 PM	1	10	0	0	11	0	0	0	0	0	4	21	3	0	28	2	0	0	0	2	5	16	1	0	22	0	0	0	0	0	0	15	0	0	15	0	0	0	0	0	76					
5:00:00 PM	4	5	3	0	12	0	0	0	0	0	7	11	1	0	19	2	0	0	0	2	2	18	2	0	22	0	0	0	0	0	2	16	1	0	19	0	0	0	0	0	73					
<b>Grand Total</b>	<b>9</b>	<b>36</b>	<b>8</b>	<b>0</b>	<b>53</b>	<b>2</b>	<b>0</b>	<b>0</b>	<b>0</b>	<b>2</b>	<b>18</b>	<b>65</b>	<b>8</b>	<b>0</b>	<b>91</b>	<b>4</b>	<b>0</b>	<b>0</b>	<b>0</b>	<b>4</b>	<b>12</b>	<b>56</b>	<b>4</b>	<b>0</b>	<b>72</b>	<b>2</b>	<b>0</b>	<b>0</b>	<b>0</b>	<b>2</b>	<b>3</b>	<b>68</b>	<b>5</b>	<b>0</b>	<b>76</b>	<b>0</b>	<b>0</b>	<b>0</b>	<b>0</b>	<b>0</b>	<b>292</b>					
<b>% Approach</b>	15.4%	69.2%	15.4%	0.0%	0.0%	0.0%	0.0%	0.0%	0.0%	0.0%	19.6%	70.7%	9.8%	0.0%	0.0%	0.0%	0.0%	0.0%	0.0%	0.0%	16.7%	77.8%	5.6%	0.0%	0.0%	0.0%	0.0%	0.0%	0.0%	0.0%	3.9%	89.5%	6.6%	0.0%	0.0%	0.0%	0.0%	0.0%	0.0%	0.0%						
<b>% Total</b>	2.7%	12.3%	2.7%	0.0%	17.8%	0.6%	22.3%	3.1%	0.0%	31.5%	0.6%	22.3%	3.1%	0.0%	31.5%	0.0%	0.0%	0.0%	0.0%	0.0%	4.1%	19.2%	1.4%	0.0%	24.7%	0.0%	0.0%	0.0%	0.0%	0.0%	1.0%	23.3%	1.7%	0.0%	26.0%	0.0%	0.0%	0.0%	0.0%	0.0%						
<b>PHF</b>	0.500	0.692	0.500	0.000	0.765	0.000	0.000	0.000	0.000	0.000	0.643	0.774	0.750	0.000	0.821	0.000	0.000	0.000	0.000	0.000	0.600	0.778	0.500	0.000	0.818	0.000	0.000	0.000	0.000	0.000	0.375	0.895	0.417	0.000	0.905	0.000	0.000	0.000	0.000	0.000						
<b>Lights</b>	7	34	7	0	48	0	0	0	0	0	16	63	8	0	87	0	0	0	0	0	11	56	4	0	71	0	0	0	0	0	3	64	5	0	72	0	0	0	0	0	278					
<b>% Lights</b>	87.5%	94.4%	87.5%	0.0%	92.3%	0.0%	0.0%	0.0%	0.0%	0.0%	88.9%	96.9%	88.9%	0.0%	94.6%	0.0%	0.0%	0.0%	0.0%	0.0%	81.7%	100.0%	100.0%	0.0%	98.6%	0.0%	0.0%	0.0%	0.0%	0.0%	100.0%	94.1%	100.0%	0.0%	94.7%	0.0%	0.0%	0.0%	0.0%	0.0%						
<b>Trucks</b>	0	0	0	0	0	0	0	0	0	0	0	0	0	0	0	0	0	0	0	0	0	0	0	0	0	0	0	0	0	0	0	0	0	0	0	0	0	0	0	0	0					
<b>% Trucks</b>	0.0%	0.0%	0.0%	0.0%	0.0%	0.0%	0.0%	0.0%	0.0%	0.0%	0.0%	0.0%	0.0%	0.0%	0.0%	0.0%	0.0%	0.0%	0.0%	0.0%	0.0%	0.0%	0.0%	0.0%	0.0%	0.0%	0.0%	0.0%	0.0%	0.0%	0.0%	0.0%	0.0%	0.0%	0.0%	0.0%	0.0%	0.0%	0.0%	0.0%						
<b>Buses</b>	1	2	1	0	4	2	2	1	0	5	0	0	0	0	0	1	0	0	0	1	0	0	0	0	0	0	4	0	0	4	0	0	0	0	0	4	0	0	0	4	0	0	0	0	0	14
<b>% Buses</b>	12.5%	5.6%	12.5%	0.0%	0.0%	11.1%	3.1%	11.1%	0.0%	0.0%	0.0%	0.0%	0.0%	0.0%	0.0%	8.3%	0.0%	0.0%	0.0%	0.0%	0.0%	0.0%	0.0%	0.0%	0.0%	0.0%	5.9%	0.0%	0.0%	0.0%	0.0%	0.0%	0.0%	0.0%	0.0%	4.8%	0.0%	0.0%	0.0%	0.0%						
<b>Pedestrians</b>	0	0	0	0	0	2	0	0	0	2	0	0	0	0	0	0	0	0	0	0	0	0	0	0	0	2	0	0	0	2	0	0	0	0	0	0	0	0	0	0	1	0	0	0	1	0
<b>% Pedestrians</b>	0.0%	0.0%	0.0%	0.0%	0.0%	100.0%	0.0%	0.0%	0.0%	0.0%	0.0%	0.0%	0.0%	0.0%	0.0%	0.0%	0.0%	0.0%	0.0%	0.0%	0.0%	0.0%	0.0%	0.0%	0.0%	100.0%	0.0%	0.0%	0.0%	0.0%	0.0%	0.0%	0.0%	0.0%	0.0%	0.0%	0.0%	0.0%	0.0%	0.0%						
<b>Bicycles on Crosswalk</b>	0	0	0	0	0	0	0	0	0	0	0	0	0	0	0	0	0	0	0	0	0	0	0	0	0	0	0	0	0	0	0	0	0	0	0	0	0	0	0	0	0	0	0	0	0	0
<b>% Bicycles on Crosswalk</b>	0.0%	0.0%	0.0%	0.0%	0.0%	0.0%	0.0%	0.0%	0.0%	0.0%	0.0%	0.0%	0.0%	0.0%	0.0%	0.0%	0.0%	0.0%	0.0%	0.0%	0.0%	0.0%	0.0%	0.0%	0.0%	0.0%	0.0%	0.0%	0.0%	0.0%	0.0%	0.0%	0.0%	0.0%	0.0%	0.0%	0.0%	0.0%	0.0%	0.0%						

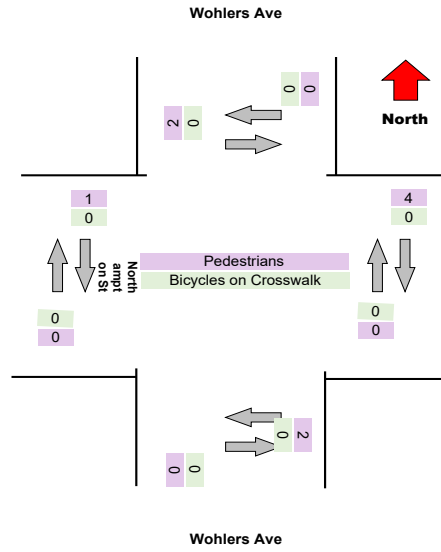
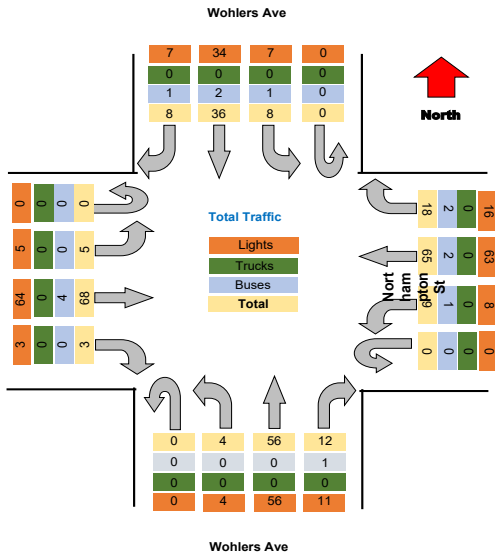



**Turning Movement Data Plot**

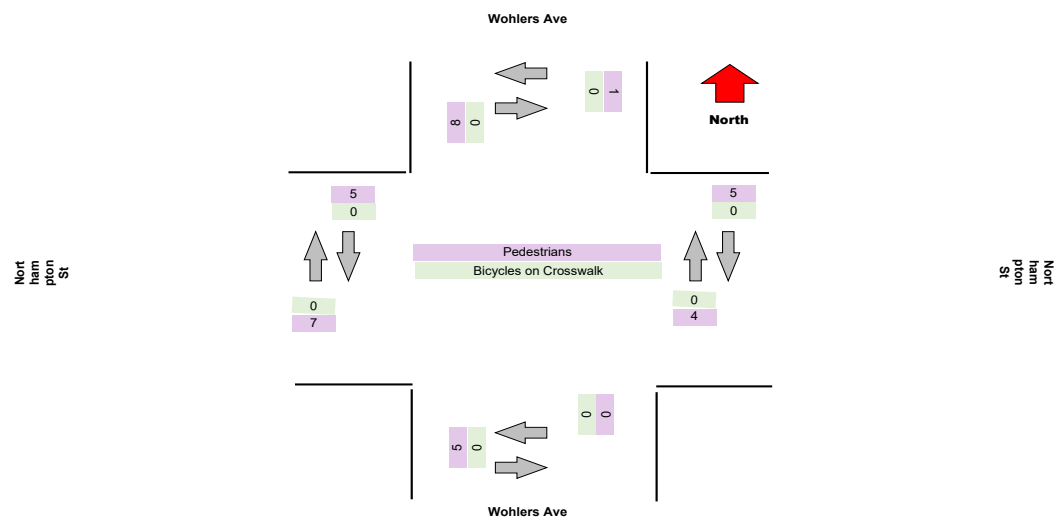
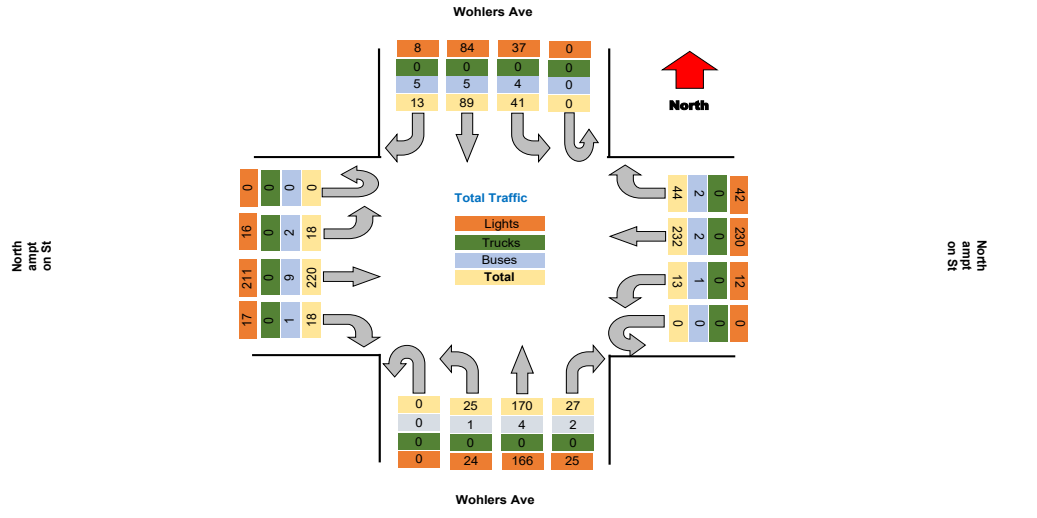

**Turning Movement Peak Hour Data (AM)**

7:30:00 AM

Leg Direction	Wohlers Ave					Northampton St					Wohlers Ave					Northampton St					Total									
	Southbound					Westbound					Northbound					Eastbound														
Start Time	Right	Thru	Left	U-Turn	App Total	Peds CW	Peds CCW	Right	Thru	Left	U-Turn	App Total	Peds CW	Peds CCW	Right	Thru	Left	U-Turn	App Total	Peds CW	Peds CCW	Right	Thru	Left	U-Turn	App Total	Peds CW	Peds CCW		
7:30:00 AM	1	4	0	0	5	1	1	1	11	2	0	15	1	0	1	6	1	0	9	0	0	1	8	1	0	10	2	1	39	
7:45:00 AM	1	4	5	0	10	0	0	3	14	0	0	17	0	0	1	8	2	0	11	0	0	0	20	1	0	21	0	0	59	
8:00:00 AM	0	0	1	0	1	0	0	1	17	0	0	18	0	0	3	3	2	0	8	0	2	1	11	1	0	13	0	1	40	
8:15:00 AM	3	3	4	0	10	0	0	2	19	0	0	21	0	0	0	3	3	0	11	0	0	1	13	3	0	17	0	0	59	
<b>Grand Total</b>	<b>5</b>	<b>11</b>	<b>10</b>	<b>0</b>	<b>26</b>	<b>1</b>	<b>1</b>	<b>7</b>	<b>61</b>	<b>2</b>	<b>0</b>	<b>71</b>	<b>1</b>	<b>0</b>	<b>5</b>	<b>25</b>	<b>8</b>	<b>0</b>	<b>39</b>	<b>0</b>	<b>0</b>	<b>3</b>	<b>52</b>	<b>8</b>	<b>0</b>	<b>61</b>	<b>2</b>	<b>2</b>	<b>197</b>	
% Approach	19.2%	42.3%	38.5%	0.0%	0.0%	0.0%	0.0%	9.9%	85.9%	2.8%	0.0%	0.0%	0.0%	0.0%	12.8%	64.1%	20.5%	0.0%	0.0%	0.0%	0.0%	4.9%	85.2%	9.8%	0.0%	0.0%	0.0%	0.0%	0.0%	
% Total	2.5%	5.6%	5.1%	0.0%	13.2%	0.0%	0.0%	3.6%	31.0%	1.0%	0.0%	36.0%	0.0%	0.0%	2.5%	12.7%	4.1%	0.0%	19.8%	0.0%	0.0%	1.5%	26.4%	3.0%	0.0%	31.0%	0.0%	0.0%	0.0%	
PHF	0.417	0.688	0.500	0.000	0.650	0.000	0.000	0.583	0.803	0.250	0.000	0.845	0.000	0.000	0.417	0.781	0.667	0.000	0.886	0.000	0.000	0.750	0.650	0.500	0.000	0.726	0.000	0.000	0.835	
Lights	3	10	8	0	21	0	0	6	61	2	0	69	0	0	5	23	7	0	35	0	0	3	48	4	0	55	0	0	180	
% Lights	60.0%	90.9%	80.0%	0.0%	80.8%	0.0%	0.0%	85.7%	100.0%	100.0%	0.0%	97.2%	0.0%	0.0%	100.0%	92.0%	87.5%	0.0%	89.7%	0.0%	0.0%	100.0%	92.3%	66.7%	0.0%	90.2%	0.0%	0.0%	91.4%	
Trucks	0	0	0	0	0	0	0	0	0	0	0	0	0	0	0	0	0	0	0	0	0	0	0	0	0	0	0	0	0	
% Trucks	0.0%	0.0%	0.0%	0.0%	0.0%	0.0%	0.0%	0.0%	0.0%	0.0%	0.0%	0.0%	0.0%	0.0%	0.0%	0.0%	0.0%	0.0%	0.0%	0.0%	0.0%	0.0%	0.0%	0.0%	0.0%	0.0%	0.0%	0.0%	0.0%	
Buses	2	1	2	0	5	0	0	1	0	0	0	1	0	0	0	2	1	0	3	0	0	0	4	2	0	6	0	0	15	
% Buses	40.0%	9.1%	20.0%	0.0%	0.0%	0.0%	0.0%	14.3%	0.0%	0.0%	0.0%	0.0%	0.0%	0.0%	0.0%	8.0%	12.5%	0.0%	0.0%	0.0%	0.0%	0.0%	7.7%	33.3%	0.0%	0.0%	0.0%	0.0%	7.6%	
Pedestrians	0	0	0	0	0	1	1	0	0	0	0	0	1	0	0	0	0	0	0	0	3	0	0	0	0	0	2	2	0	
% Pedestrians	0.0%	0.0%	0.0%	0.0%	0.0%	100.0%	100.0%	0.0%	0.0%	0.0%	0.0%	0.0%	100.0%	0.0%	0.0%	0.0%	0.0%	0.0%	0.0%	0.0%	100.0%	100.0%	0.0%	0.0%	0.0%	0.0%	0.0%	100.0%	100.0%	0.0%
Bicycles on Crosswalk	0	0	0	0	0	0	0	0	0	0	0	0	0	0	0	0	0	0	0	0	0	0	0	0	0	0	0	0	0	
% Bicycles on Crosswalk	0.0%	0.0%	0.0%	0.0%	0.0%	0.0%	0.0%	0.0%	0.0%	0.0%	0.0%	0.0%	0.0%	0.0%	0.0%	0.0%	0.0%	0.0%	0.0%	0.0%	0.0%	0.0%	0.0%	0.0%	0.0%	0.0%	0.0%	0.0%	0.0%	

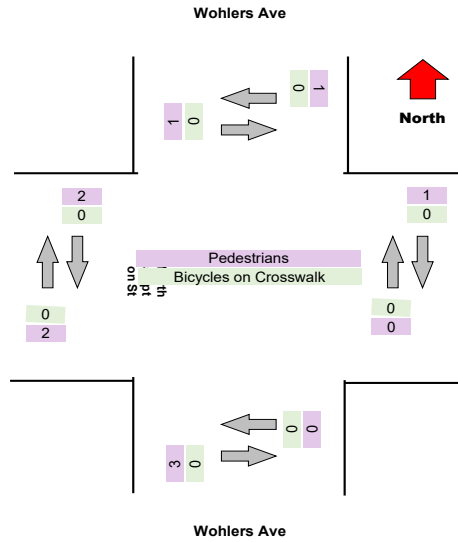
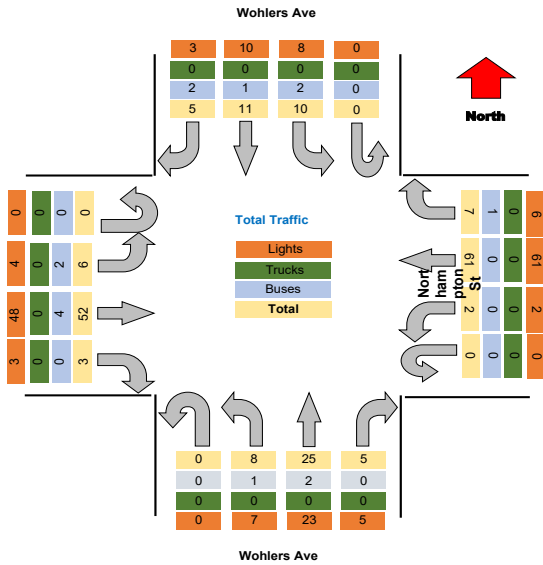

### Turning Movement Peak Hour Data (PM)

4:15:00 PM

Leg Direction	Wohlers Ave										Northampton St										Total									
	Southbound					Westbound					Northbound					Eastbound														
	Right	Thru	Left	U-Turn	App Total	Peds CW	Peds CCW	Right	Thru	Left	U-Turn	App Total	Peds CW	Peds CCW	Right	Thru	Left	U-Turn	App Total	Peds CW		Peds CCW								
4:15:00 PM	2	8	6	0	16	0	0	3	20	3	0	26	1	0	5	17	0	0	22	0	0	4	18	3	0	25	0	0	89	
4:30:00 PM	0	10	5	0	15	2	0	6	18	0	0	24	1	1	2	19	2	0	23	0	1	3	22	1	0	26	0	0	88	
4:45:00 PM	2	8	3	0	13	4	0	4	21	1	0	26	0	0	3	15	6	0	24	0	0	1	22	1	0	24	5	1	87	
5:00:00 PM	3	2	1	0	6	0	0	1	16	1	0	18	0	0	1	19	3	0	23	0	0	0	21	1	0	22	0	0	69	
<b>Grand Total</b>	<b>7</b>	<b>28</b>	<b>15</b>	<b>0</b>	<b>50</b>	<b>6</b>	<b>0</b>	<b>14</b>	<b>75</b>	<b>5</b>	<b>0</b>	<b>94</b>	<b>2</b>	<b>1</b>	<b>11</b>	<b>70</b>	<b>11</b>	<b>0</b>	<b>82</b>	<b>0</b>	<b>1</b>	<b>8</b>	<b>83</b>	<b>6</b>	<b>0</b>	<b>97</b>	<b>5</b>	<b>1</b>	<b>333</b>	
% Approach	14.0%	56.0%	30.0%	0.0%	0.0%	0.0%	0.0%	14.5%	79.8%	5.3%	0.0%	0.0%	0.0%	0.0%	12.0%	76.1%	12.0%	0.0%	0.0%	0.0%	0.0%	0.0%	8.2%	85.6%	6.2%	0.0%	0.0%	0.0%	0.0%	0.0%
% Total	2.1%	8.4%	4.5%	0.0%	15.0%	0.0%	0.0%	4.2%	22.5%	1.5%	0.0%	28.2%	0.0%	0.0%	3.3%	21.0%	3.3%	0.0%	27.6%	0.0%	0.0%	2.4%	24.9%	1.8%	0.0%	29.1%	0.0%	0.0%	0.0%	
PHF	0.583	0.700	0.625	0.000	0.781	0.000	0.000	0.583	0.893	0.417	0.000	0.904	0.000	0.000	0.550	0.921	0.458	0.000	0.858	0.000	0.000	0.500	0.843	0.500	0.000	0.933	0.000	0.000	0.935	
Lights	5	27	13	0	45	0	0	13	74	5	0	92	0	0	10	70	11	0	91	0	0	7	80	6	0	93	0	0	321	
% Lights	71.4%	96.4%	86.7%	0.0%	90.0%	0.0%	0.0%	92.9%	98.7%	100.0%	0.0%	97.9%	0.0%	0.0%	80.9%	100.0%	100.0%	0.0%	98.9%	0.0%	0.0%	87.5%	96.4%	100.0%	0.0%	95.9%	0.0%	0.0%	96.4%	
Trucks	0	0	0	0	0	0	0	0	0	0	0	0	0	0	0	0	0	0	0	0	0	0	0	0	0	0	0	0	0	
% Trucks	0.0%	0.0%	0.0%	0.0%	0.0%	0.0%	0.0%	0.0%	0.0%	0.0%	0.0%	0.0%	0.0%	0.0%	0.0%	0.0%	0.0%	0.0%	0.0%	0.0%	0.0%	0.0%	0.0%	0.0%	0.0%	0.0%	0.0%	0.0%	0.0%	
Buses	2	1	2	0	5	0	0	1	1	0	0	2	0	0	1	0	0	0	1	0	0	1	3	0	0	4	0	0	12	
% Buses	28.6%	3.6%	13.3%	0.0%	0.0%	0.0%	0.0%	7.1%	1.3%	0.0%	0.0%	0.0%	0.0%	0.0%	9.1%	0.0%	0.0%	0.0%	0.0%	0.0%	0.0%	12.5%	3.6%	0.0%	0.0%	0.0%	0.0%	0.0%	3.6%	
Pedestrians	0	0	0	0	0	6	0	0	0	0	0	0	2	2	0	0	0	0	0	1	0	0	0	0	0	0	5	1	0	
% Pedestrians	0.0%	0.0%	0.0%	0.0%	0.0%	100.0%	0.0%	0.0%	0.0%	0.0%	0.0%	0.0%	100.0%	100.0%	0.0%	0.0%	0.0%	0.0%	0.0%	0.0%	0.0%	0.0%	0.0%	0.0%	0.0%	0.0%	0.0%	100.0%	100.0%	0.0%
Bicycles on Crosswalk	0	0	0	0	0	0	0	0	0	0	0	0	0	0	0	0	0	0	0	0	0	0	0	0	0	0	0	0	0	
% Bicycles on Crosswalk	0.0%	0.0%	0.0%	0.0%	0.0%	0.0%	0.0%	0.0%	0.0%	0.0%	0.0%	0.0%	0.0%	0.0%	0.0%	0.0%	0.0%	0.0%	0.0%	0.0%	0.0%	0.0%	0.0%	0.0%	0.0%	0.0%	0.0%	0.0%	0.0%	

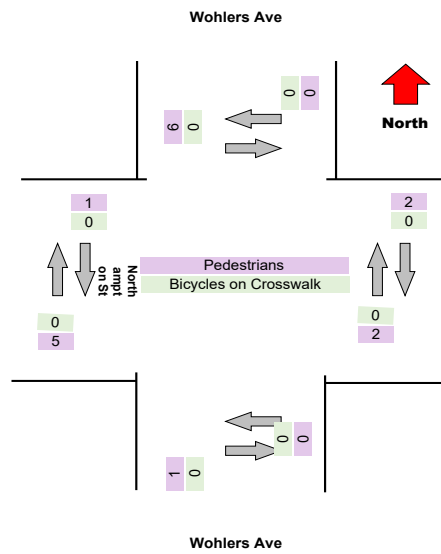
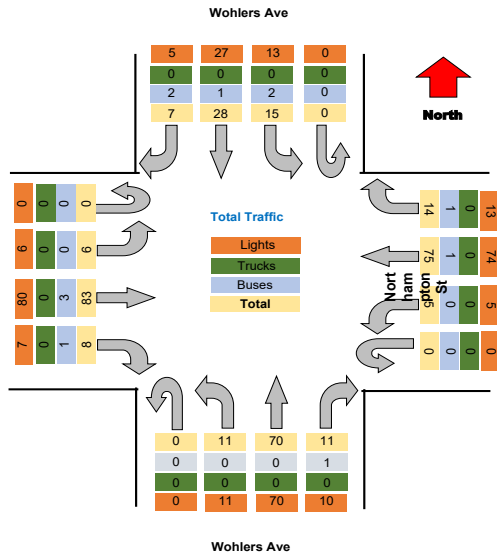





Project : VBH Malta NY  
 Site : Site 4  
 Location : 42.948550, -73.790036  
 Survey Date : 2021-04-28, Wednesday

**Turning Movement Data Plot**

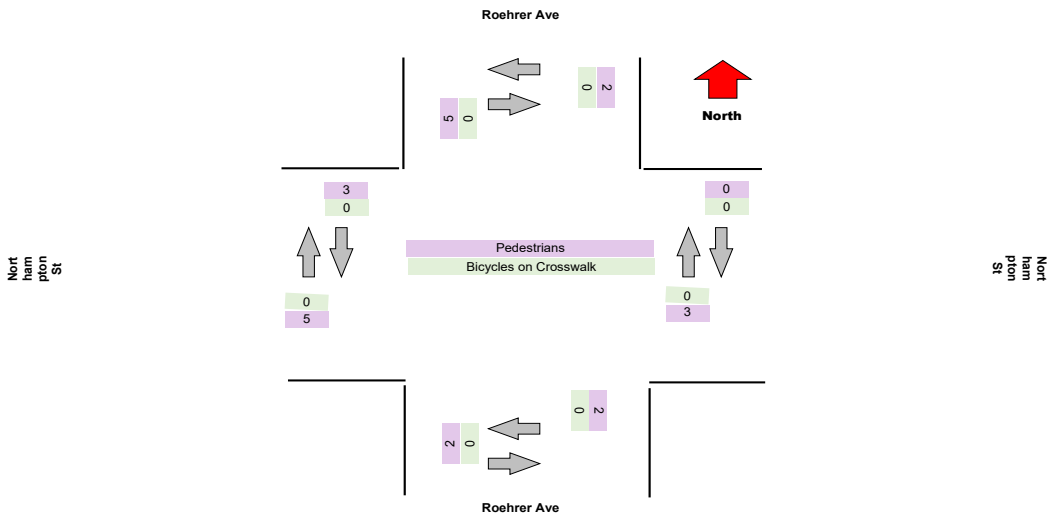
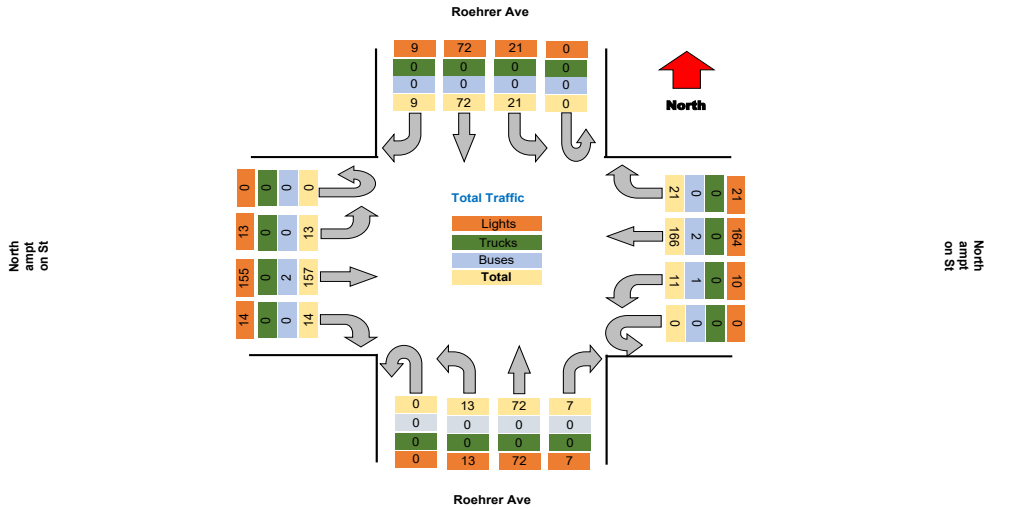

Project : VBH Malta NY  
Site : Site 4  
Location : 42.948550, -73.790036  
Survey Date : 2021-04-28, Wednesday

TSTData.com

**Turning Movement Peak Hour Data (AM)**

7:30:00 AM

Leg Direction	Roehrer Ave						Northampton St						Roehrer Ave						Northampton St						Total					
	Southbound			Northbound			Westbound			Eastbound			Northbound			Eastbound														
Start Time	Right	Thru	Left	U-Turn	App Total	Peds CW	Peds CCW	Right	Thru	Left	U-Turn	App Total	Peds CW	Peds CCW	Right	Thru	Left	U-Turn	App Total	Peds CW	Peds CCW	Right	Thru	Left	U-Turn	App Total	Peds CW	Peds CCW		
7:30:00 AM	0	3	0	0	3	0	0	1	9	0	0	10	0	0	0	2	0	0	2	1	0	0	0	8	0	0	8	0	0	23
7:45:00 AM	0	3	0	0	3	0	0	1	9	1	0	11	0	0	0	6	3	0	9	0	0	0	1	10	1	0	12	0	0	35
8:00:00 AM	2	3	0	0	5	0	0	2	12	0	0	14	0	0	0	4	1	0	5	0	0	0	5	2	0	8	1	0	32	
8:15:00 AM	1	3	0	0	4	0	0	0	20	1	0	21	0	0	0	0	0	0	0	1	0	0	0	13	0	0	13	0	0	38
<b>Grand Total</b>	<b>3</b>	<b>12</b>	<b>0</b>	<b>0</b>	<b>15</b>	<b>0</b>	<b>0</b>	<b>4</b>	<b>50</b>	<b>2</b>	<b>0</b>	<b>56</b>	<b>0</b>	<b>0</b>	<b>0</b>	<b>12</b>	<b>4</b>	<b>0</b>	<b>16</b>	<b>2</b>	<b>0</b>	<b>2</b>	<b>36</b>	<b>3</b>	<b>0</b>	<b>41</b>	<b>1</b>	<b>0</b>	<b>128</b>	
% Approach	20.0%	80.0%	0.0%	0.0%	0.0%	0.0%	0.0%	7.1%	89.3%	3.6%	0.0%	0.0%	0.0%	0.0%	0.0%	75.0%	25.0%	0.0%	0.0%	0.0%	0.0%	4.9%	87.8%	7.3%	0.0%	0.0%	0.0%	0.0%	0.0%	
% Total	2.3%	9.4%	0.0%	0.0%	11.7%	0.0%	0.0%	3.1%	39.1%	1.6%	0.0%	43.8%	0.0%	0.0%	0.0%	9.4%	3.1%	0.0%	12.5%	0.0%	0.0%	1.6%	28.1%	2.3%	0.0%	32.0%	0.0%	0.0%	0.8%	
PHF	0.375	1.000	0.000	0.000	0.750	0.000	0.000	0.500	0.625	0.500	0.000	0.667	0.000	0.000	0.000	0.500	0.333	0.000	0.444	0.000	0.000	0.500	0.692	0.375	0.000	0.788	0.000	0.000	0.842	
Lights	3	12	0	0	15	0	0	4	50	2	0	56	0	0	0	12	4	0	16	0	0	2	36	3	0	40	0	0	127	
% Lights	100.0%	100.0%	0.0%	0.0%	100.0%	0.0%	0.0%	100.0%	100.0%	100.0%	0.0%	100.0%	0.0%	0.0%	0.0%	100.0%	100.0%	0.0%	100.0%	0.0%	0.0%	100.0%	97.2%	100.0%	0.0%	97.6%	0.0%	0.0%	99.2%	
Trucks	0	0	0	0	0	0	0	0	0	0	0	0	0	0	0	0	0	0	0	0	0	0	0	0	0	0	0	0	0	
% Trucks	0.0%	0.0%	0.0%	0.0%	0.0%	0.0%	0.0%	0.0%	0.0%	0.0%	0.0%	0.0%	0.0%	0.0%	0.0%	0.0%	0.0%	0.0%	0.0%	0.0%	0.0%	0.0%	0.0%	0.0%	0.0%	0.0%	0.0%	0.0%	0.0%	
Buses	0	0	0	0	0	0	0	0	0	0	0	0	0	0	0	0	0	0	0	0	0	0	1	0	0	1	0	0	1	
% Buses	0.0%	0.0%	0.0%	0.0%	0.0%	0.0%	0.0%	0.0%	0.0%	0.0%	0.0%	0.0%	0.0%	0.0%	0.0%	0.0%	0.0%	0.0%	0.0%	0.0%	0.0%	0.0%	2.8%	0.0%	0.0%	0.0%	0.0%	0.0%	0.8%	
Pedestrians	0	0	0	0	0	0	0	0	0	0	0	0	0	0	0	0	0	0	0	2	0	0	0	0	0	0	1	0	0	
% Pedestrians	0.0%	0.0%	0.0%	0.0%	0.0%	0.0%	0.0%	0.0%	0.0%	0.0%	0.0%	0.0%	0.0%	0.0%	0.0%	0.0%	0.0%	0.0%	0.0%	0.0%	100.0%	0.0%	0.0%	0.0%	0.0%	0.0%	100.0%	0.0%	0.0%	
Bicycles on Crosswalk	0	0	0	0	0	0	0	0	0	0	0	0	0	0	0	0	0	0	0	0	0	0	0	0	0	0	0	0	0	
% Bicycles on Crosswalk	0.0%	0.0%	0.0%	0.0%	0.0%	0.0%	0.0%	0.0%	0.0%	0.0%	0.0%	0.0%	0.0%	0.0%	0.0%	0.0%	0.0%	0.0%	0.0%	0.0%	0.0%	0.0%	0.0%	0.0%	0.0%	0.0%	0.0%	0.0%	0.0%	

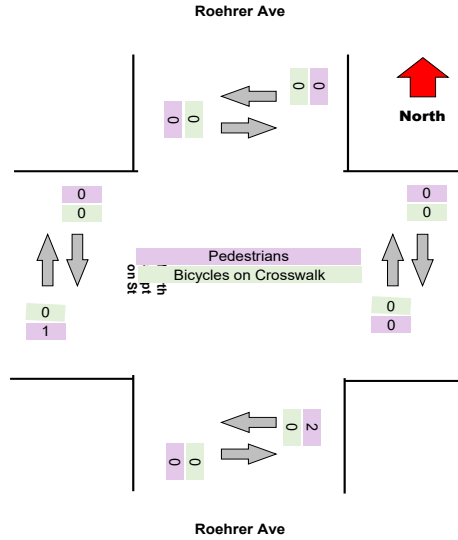
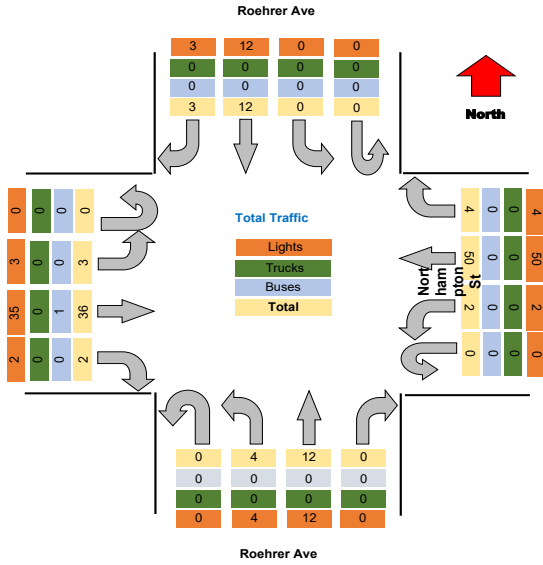

**Turning Movement Peak Hour Data (PM)**

4:30:00 PM

Leg Direction	Roehrer Ave				Northampton St				Roehrer Ave				Northampton St				Total													
	Southbound		Westbound		Northbound		Eastbound		Northbound		Eastbound		Northbound		Eastbound															
Start Time	Right	Thru	Left	U-Turn	App Total	Peds CW	Peds CCW	Right	Thru	Left	U-Turn	App Total	Peds CW	Peds CCW	Right	Thru	Left	U-Turn	App Total	Peds CW	Peds CCW									
4:30:00 PM	1	6	1	0	8	0	1	2	11	1	0	14	0	1	0	6	4	0	10	0	0	3	6	2	0	11	0	0	43	
4:45:00 PM	0	7	4	0	11	1	0	2	13	2	0	17	0	0	1	8	1	0	10	0	0	0	23	1	0	24	0	0	62	
5:00:00 PM	1	11	1	0	13	1	1	5	19	1	0	25	0	0	2	5	0	0	7	0	0	1	21	1	0	23	2	3	68	
5:15:00 PM	1	8	1	0	10	0	0	2	16	0	0	18	0	1	1	4	0	0	5	0	2	0	8	3	0	11	0	0	44	
<b>Grand Total</b>	<b>3</b>	<b>32</b>	<b>7</b>	<b>0</b>	<b>42</b>	<b>2</b>	<b>2</b>	<b>11</b>	<b>59</b>	<b>4</b>	<b>0</b>	<b>74</b>	<b>0</b>	<b>2</b>	<b>4</b>	<b>23</b>	<b>5</b>	<b>0</b>	<b>32</b>	<b>0</b>	<b>2</b>	<b>4</b>	<b>58</b>	<b>7</b>	<b>0</b>	<b>59</b>	<b>2</b>	<b>3</b>	<b>217</b>	
% Approach	7.1%	76.2%	16.7%	0.0%	0.0%	0.0%	0.0%	14.5%	79.7%	5.4%	0.0%	0.0%	0.0%	0.0%	12.5%	71.9%	15.6%	0.0%	0.0%	0.0%	0.0%	5.8%	84.1%	10.1%	0.0%	0.0%	0.0%	0.0%	0.0%	
% Total	1.4%	14.7%	3.2%	0.0%	19.4%	0.0%	0.0%	5.1%	27.2%	1.8%	0.0%	34.1%	0.0%	0.0%	1.8%	10.6%	2.3%	0.0%	14.7%	0.0%	0.0%	1.8%	26.7%	3.2%	0.0%	31.8%	0.0%	0.0%	0.0%	
PHF	0.750	0.727	0.438	0.000	0.808	0.000	0.000	0.550	0.776	0.500	0.000	0.740	0.000	0.000	0.500	0.719	0.313	0.000	0.800	0.000	0.000	0.333	0.630	0.583	0.000	0.719	0.000	0.000	0.798	
Lights	3	32	7	0	42	0	0	11	58	4	0	73	0	0	4	23	5	0	32	0	0	4	57	7	0	68	0	0	215	
% Lights	100.0%	100.0%	100.0%	0.0%	100.0%	0.0%	0.0%	100.0%	98.3%	100.0%	0.0%	98.6%	0.0%	0.0%	100.0%	100.0%	100.0%	0.0%	100.0%	0.0%	0.0%	100.0%	98.3%	100.0%	0.0%	98.6%	0.0%	0.0%	99.1%	
Trucks	0	0	0	0	0	0	0	0	0	0	0	0	0	0	0	0	0	0	0	0	0	0	0	0	0	0	0	0	0	
% Trucks	0.0%	0.0%	0.0%	0.0%	0.0%	0.0%	0.0%	0.0%	0.0%	0.0%	0.0%	0.0%	0.0%	0.0%	0.0%	0.0%	0.0%	0.0%	0.0%	0.0%	0.0%	0.0%	0.0%	0.0%	0.0%	0.0%	0.0%	0.0%	0.0%	
Buses	0	0	0	0	0	0	0	1	0	0	0	1	0	0	0	0	0	0	0	0	0	0	1	0	0	1	0	0	2	
% Buses	0.0%	0.0%	0.0%	0.0%	0.0%	0.0%	0.0%	0.0%	1.7%	0.0%	0.0%	0.0%	0.0%	0.0%	0.0%	0.0%	0.0%	0.0%	0.0%	0.0%	0.0%	0.0%	1.7%	0.0%	0.0%	0.0%	0.0%	0.0%	0.9%	
Pedestrians	0	0	0	0	0	2	2	0	0	0	0	0	2	0	0	0	0	0	0	0	2	0	0	0	0	0	2	3	0	
% Pedestrians	0.0%	0.0%	0.0%	0.0%	0.0%	100.0%	100.0%	0.0%	0.0%	0.0%	0.0%	0.0%	100.0%	0.0%	0.0%	0.0%	0.0%	0.0%	0.0%	0.0%	100.0%	0.0%	0.0%	0.0%	0.0%	0.0%	0.0%	100.0%	100.0%	0.0%
Bicycles on Crosswalk	0	0	0	0	0	0	0	0	0	0	0	0	0	0	0	0	0	0	0	0	0	0	0	0	0	0	0	0	0	
% Bicycles on Crosswalk	0.0%	0.0%	0.0%	0.0%	0.0%	0.0%	0.0%	0.0%	0.0%	0.0%	0.0%	0.0%	0.0%	0.0%	0.0%	0.0%	0.0%	0.0%	0.0%	0.0%	0.0%	0.0%	0.0%	0.0%	0.0%	0.0%	0.0%	0.0%	0.0%	

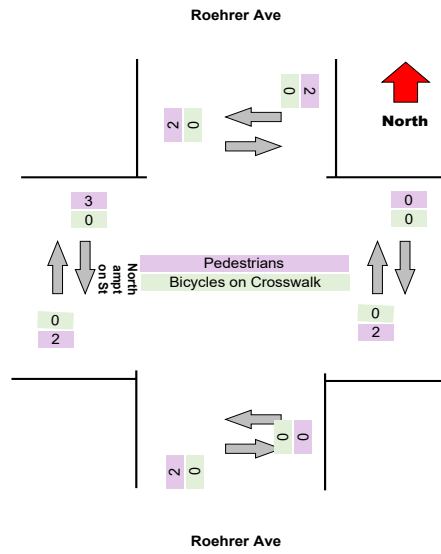
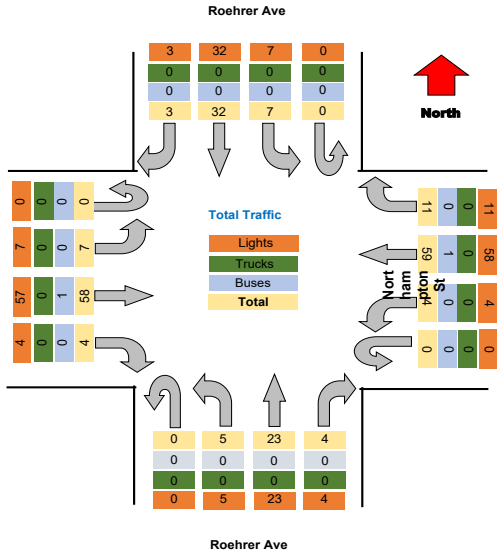

Project : VBH Malta NY  
Site : Site 4  
Location : 42.948550, -73.790036

TSTData.com

Survey Date : 2021-04-28, Wednesday

Project	LaBella
Project Code	LaBella
Site Name	S
Legs and Movements	All Processed Legs & Move
Bin Size	15 minutes
Survey Date	2021-11-03, Wednesday
Location	S
Latitude and Longitude	42.907387, -78.849134

	Start	End	PHF
Forced Peak AM	2021/11/03 07:30:00	2021/11/03 08:30:00	0.83
Forced Peak PM	2021/11/03 16:30:00	2021/11/03 17:30:00	0.81
AM Peak	2021/11/03 07:30:00	2021/11/03 08:30:00	0.83
PM Peak	2021/11/03 16:30:00	2021/11/03 17:30:00	0.81

### Turning Movement Data

Leg Direction	Roehrer Ave								Northampton St								Roehrer Ave								Northampton St								Total
	Southbound				Westbound				Northbound				Eastbound				Southbound				Westbound				Northbound				Eastbound				
	Right	Thru	Left	U-Turn	App Total	Peds CV	Peds CCV		Right	Thru	Left	U-Turn	App Total	Peds CV	Peds CCV		Right	Thru	Left	U-Turn	App Total	Peds CV	Peds CCV		Right	Thru	Left	U-Turn	App Total	Peds CV	Peds CCV		
Start Time																																	
6:30:00 AM	0	2	0	0	2	1	0		1	4	0	0	5	0	0		0	4	1	0	5	0	0		0	2	0	0	2	0	0		14
6:45:00 AM	0	0	1	0	1	0	0		0	12	2	0	14	0	0		0	3	1	0	4	0	0		0	3	2	0	5	0	0		24
Hourly Total	0	2	1	0	3	1	0		1	16	2	0	19	0	0		0	7	2	0	9	0	0		0	5	2	0	7	0	0		38
7:00:00 AM	2	2	0	0	4	0	0		0	8	0	0	8	0	0		1	2	0	0	3	0	0		1	4	0	0	5	0	0		18
7:15:00 AM	1	3	1	0	5	0	0		1	8	1	0	10	0	0		0	2	2	0	4	0	0		1	5	1	0	7	1	0		28
7:30:00 AM	1	3	0	0	4	0	1		0	11	2	0	14	0	0		0	0	2	0	2	0	0		1	10	0	0	11	0	0		31
7:45:00 AM	0	7	1	0	8	1	0		1	17	1	0	19	0	0		2	3	2	0	7	0	0		1	14	0	0	15	1	1		49
Hourly Total	4	15	2	0	21	1	1		2	42	4	0	49	0	0		3	7	6	0	16	0	0		4	33	1	0	38	2	1		124
8:00:00 AM	1	5	3	0	9	0	1		0	12	0	0	13	0	0		0	6	1	0	7	0	0		0	9	0	0	9	0	0		38
8:15:00 AM	1	4	1	0	6	0	0		0	22	1	0	23	0	0		0	2	3	0	5	1	0		1	7	2	0	10	0	0		44
Hourly Total	2	9	4	0	15	0	1		0	34	1	0	36	0	0		0	8	4	0	12	1	0		1	16	2	0	19	0	0		82
4:00:00 PM	1	9	3	0	13	0	1		6	6	4	0	16	0	0		1	12	0	0	13	0	0		0	12	1	0	13	0	0		55
4:15:00 PM	1	10	3	0	14	0	0		2	18	2	0	22	1	0		3	6	0	0	9	0	0		3	16	3	0	22	0	2		67
4:30:00 PM	2	3	2	0	7	0	1		3	11	1	0	15	0	0		0	6	2	0	8	0	0		1	18	2	0	21	0	1		51
4:45:00 PM	0	9	1	0	10	0	0		6	18	0	0	24	0	0		2	5	0	0	7	0	0		3	12	1	0	16	0	0		57
Hourly Total	4	31	9	0	44	0	2		17	53	7	0	77	1	2		6	29	2	0	37	0	0		7	58	7	0	72	0	3		230
5:00:00 PM	3	4	2	0	9	1	0		2	10	3	0	15	0	0		3	4	1	0	8	0	1		1	15	1	0	17	0	0		49
5:15:00 PM	1	8	4	0	13	0	0		2	16	2	0	20	0	1		1	6	1	0	8	0	0		0	24	5	0	29	1	1		70
5:30:00 PM	1	5	3	0	9	0	1		1	7	1	0	9	3	0		0	6	0	0	6	1	0		1	18	1	0	20	0	1		44
5:45:00 PM	0	5	4	0	9	0	1		2	13	3	0	18	0	0		0	7	2	0	9	0	0		0	14	2	0	16	0	1		52
Hourly Total	5	22	13	0	40	1	2		7	46	9	0	62	3	1		4	23	4	0	31	1	1		2	71	9	0	82	1	3		215
Grand Total	15	79	29	0	123	3	6		27	191	23	0	243	4	3		13	74	18	0	105	2	1		14	183	21	0	218	3	7		689
% Approach	12.2%	64.2%	23.6%	0.0%	0.0%	0.0%	0.0%		11.1%	78.6%	9.5%	0.0%	0.0%	0.0%	0.0%		12.4%	70.5%	17.1%	0.0%	0.0%	0.0%	0.0%		6.4%	83.9%	9.6%	0.0%	0.0%	0.0%	0.0%		0.0%
% Total	2.2%	11.5%	4.2%	0.0%	17.9%	0.0%	0.0%		3.9%	27.7%	3.3%	0.0%	35.3%	0.0%	0.0%		1.9%	10.7%	2.6%	0.0%	15.2%	0.0%	0.0%		2.0%	26.6%	3.0%	0.0%	31.6%	0.0%	0.0%		0.0%
Lights	14	74	29	0	117	0	0		27	187	19	0	233	0	0		9	73	15	0	97	0	0		13	174	17	0	204	0	0		651
% Lights	93.3%	93.7%	100.0%	0.0%	85.1%	0.0%	0.0%		100.0%	97.9%	82.6%	0.0%	95.9%	0.0%	0.0%		69.2%	88.6%	83.3%	0.0%	92.4%	0.0%	0.0%		92.9%	95.1%	81.0%	0.0%	93.6%	0.0%	0.0%		94.6%
Trucks	0	0	0	0	0	0	0		0	0	0	0	0	0	0		0	0	0	0	0	0	0		0	0	0	0	0	0	0		0
% Trucks	0.0%	0.0%	0.0%	0.0%	0.0%	0.0%	0.0%		0.0%	0.0%	0.0%	0.0%	0.0%	0.0%	0.0%		0.0%	0.0%	0.0%	0.0%	0.0%	0.0%	0.0%		0.0%	0.0%	0.0%	0.0%	0.0%	0.0%	0.0%		0.0%
Buses	1	5	0	0	6	0	0		0	4	4	0	8	0	0		0	4	1	3	8	0	0		1	9	4	0	14	0	0		36
% Buses	6.7%	6.3%	0.0%	0.0%	0.0%	0.0%	0.0%		0.0%	2.1%	17.4%	0.0%	0.0%	0.0%	0.0%		0.0%	1.4%	16.7%	0.0%	0.0%	0.0%	0.0%		7.1%	4.9%	19.0%	0.0%	0.0%	0.0%	0.0%		5.2%
Pedestrians	0	0	0	0	0	3	6		0	0	0	0	0	4	3		0	0	0	0	0	2	1		0	0	0	0	0	3	7		0
% Pedestrians	0.0%	0.0%	0.0%	0.0%	0.0%	100.0%	100.0%		0.0%	0.0%	0.0%	0.0%	0.0%	100.0%	100.0%		0.0%	0.0%	0.0%	0.0%	0.0%	100.0%	100.0%		0.0%	0.0%	0.0%	0.0%	0.0%	100.0%	100.0%		0.0%
Bicycles on Crosswalk	0	0	0	0	0	0	0		0	0	0	0	0	0	0		0	0	0	0	0	0	0		0	0	0	0	0	0	0		0
% Bicycles on Crosswalk	0.0%	0.0%	0.0%	0.0%	0.0%	0.0%	0.0%		0.0%	0.0%	0.0%	0.0%	0.0%	0.0%	0.0%		0.0%	0.0%	0.0%	0.0%	0.0%	0.0%	0.0%		0.0%	0.0%	0.0%	0.0%	0.0%	0.0%	0.0%		0.0%

Project : VBH Malta NY  
 Site : Site 4  
 Location : 42.948550, -73.790036  
 Survey Date : 2021-04-28, Wednesday

### Turning Movement Data Plot

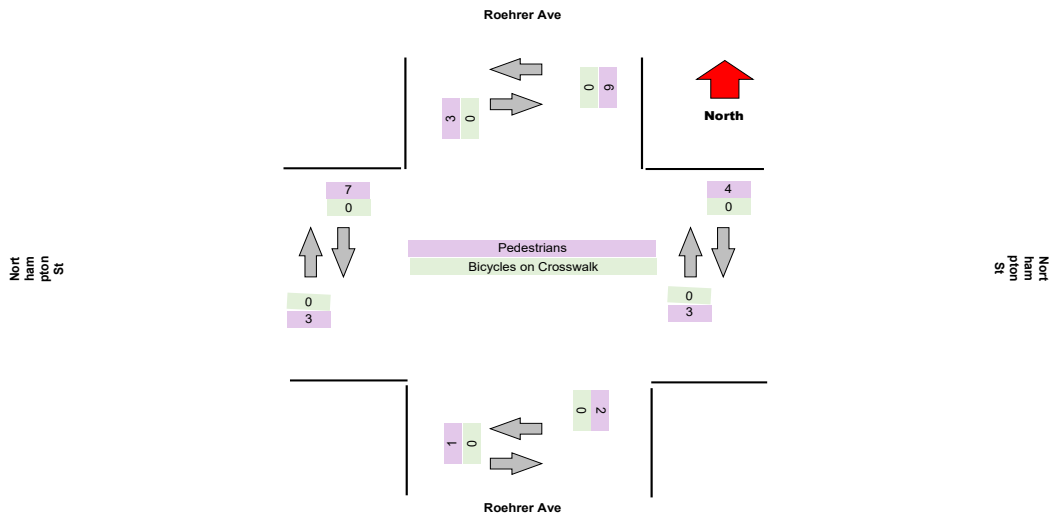
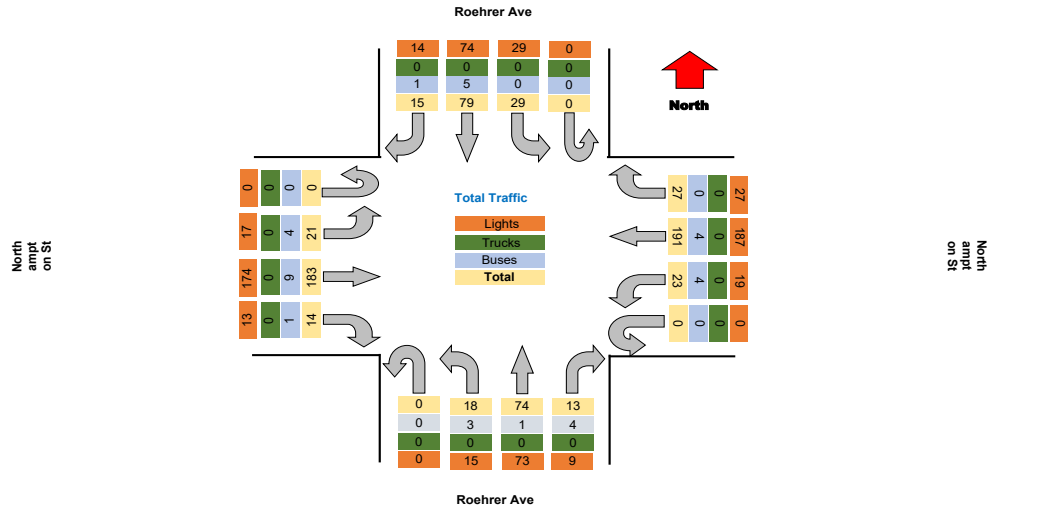



**Turning Movement Peak Hour Data (PM)**

4:30:00 PM

Leg Direction	Roehrer Ave				Northampton St				Roehrer Ave				Northampton St				Total													
	Southbound		Westbound		Northbound		Eastbound		Northbound		Eastbound		Eastbound																	
Start Time	Right	Thru	Left	U-Turn	App Total	Peds CW	Peds CCW	Right	Thru	Left	U-Turn	App Total	Peds CW	Peds CCW	Right	Thru	Left	U-Turn	App Total	Peds CW	Peds CCW									
4:30:00 PM	2	3	2	0	7	0	1	3	11	1	0	15	0	0	0	6	2	0	8	0	0	1	18	2	0	21	0	1	51	
4:45:00 PM	0	9	1	0	10	0	0	6	18	0	0	24	0	2	2	5	0	0	7	0	0	3	12	1	0	16	0	0	57	
5:00:00 PM	3	4	2	0	9	1	0	2	10	3	0	15	0	0	3	4	1	0	8	0	1	1	15	1	0	17	0	0	49	
5:15:00 PM	1	8	4	0	13	0	0	2	16	2	0	20	0	1	1	5	1	0	7	0	0	0	24	5	0	29	1	1	70	
<b>Grand Total</b>	<b>6</b>	<b>24</b>	<b>9</b>	<b>0</b>	<b>39</b>	<b>1</b>	<b>1</b>	<b>13</b>	<b>55</b>	<b>6</b>	<b>0</b>	<b>74</b>	<b>0</b>	<b>3</b>	<b>6</b>	<b>21</b>	<b>4</b>	<b>0</b>	<b>31</b>	<b>0</b>	<b>1</b>	<b>5</b>	<b>69</b>	<b>9</b>	<b>0</b>	<b>83</b>	<b>1</b>	<b>2</b>	<b>227</b>	
<b>% Approach</b>	15.4%	61.5%	23.1%	0.0%	0.0%	0.0%	0.0%	17.6%	74.3%	8.1%	0.0%	0.0%	0.0%	0.0%	19.4%	67.7%	12.9%	0.0%	0.0%	0.0%	0.0%	0.0%	6.0%	83.1%	10.8%	0.0%	0.0%	0.0%	0.0%	
<b>% Total</b>	2.6%	10.6%	4.0%	0.0%	17.2%	0.0%	0.0%	5.7%	24.2%	2.6%	0.0%	32.6%	0.0%	0.0%	2.6%	9.3%	1.8%	0.0%	13.7%	0.0%	0.0%	2.2%	30.4%	4.0%	0.0%	36.6%	0.0%	0.0%		
<b>PHF</b>	0.500	0.667	0.563	0.000	0.750	0.000	0.000	0.542	0.764	0.500	0.000	0.771	0.000	0.000	0.500	0.875	0.500	0.000	0.969	0.000	0.000	0.417	0.719	0.450	0.000	0.716	0.000	0.000	0.811	
<b>Lights</b>	5	22	9	0	36	0	0	13	54	4	0	71	0	0	5	21	2	0	28	0	0	5	68	7	0	80	0	0	215	
<b>% Lights</b>	83.3%	91.7%	100.0%	0.0%	92.3%	0.0%	0.0%	100.0%	98.2%	66.7%	0.0%	95.9%	0.0%	0.0%	83.3%	100.0%	50.0%	0.0%	90.3%	0.0%	0.0%	100.0%	98.6%	77.8%	0.0%	96.4%	0.0%	0.0%	94.7%	
<b>Trucks</b>	0	0	0	0	0	0	0	0	0	0	0	0	0	0	0	0	0	0	0	0	0	0	0	0	0	0	0	0	0	
<b>% Trucks</b>	0.0%	0.0%	0.0%	0.0%	0.0%	0.0%	0.0%	0.0%	0.0%	0.0%	0.0%	0.0%	0.0%	0.0%	0.0%	0.0%	0.0%	0.0%	0.0%	0.0%	0.0%	0.0%	0.0%	0.0%	0.0%	0.0%	0.0%	0.0%	0.0%	
<b>Buses</b>	1	2	0	0	3	0	0	0	1	2	0	3	0	0	1	0	2	0	3	0	0	0	1	2	0	3	0	0	12	
<b>% Buses</b>	16.7%	8.3%	0.0%	0.0%	0.0%	0.0%	0.0%	0.0%	1.8%	33.3%	0.0%	0.0%	0.0%	0.0%	16.7%	0.0%	50.0%	0.0%	0.0%	0.0%	0.0%	0.0%	1.4%	22.2%	0.0%	0.0%	0.0%	0.0%	5.3%	
<b>Pedestrians</b>	0	0	0	0	0	1	1	0	0	0	0	0	3	0	0	0	0	1	0	0	0	0	0	0	0	0	1	2	0	
<b>% Pedestrians</b>	0.0%	0.0%	0.0%	0.0%	0.0%	100.0%	100.0%	0.0%	0.0%	0.0%	0.0%	0.0%	100.0%	0.0%	0.0%	0.0%	0.0%	0.0%	0.0%	0.0%	0.0%	0.0%	0.0%	0.0%	0.0%	0.0%	0.0%	100.0%	100.0%	0.0%
<b>Bicycles on Crosswalk</b>	0	0	0	0	0	0	0	0	0	0	0	0	0	0	0	0	0	0	0	0	0	0	0	0	0	0	0	0	0	
<b>% Bicycles on Crosswalk</b>	0.0%	0.0%	0.0%	0.0%	0.0%	0.0%	0.0%	0.0%	0.0%	0.0%	0.0%	0.0%	0.0%	0.0%	0.0%	0.0%	0.0%	0.0%	0.0%	0.0%	0.0%	0.0%	0.0%	0.0%	0.0%	0.0%	0.0%	0.0%	0.0%	

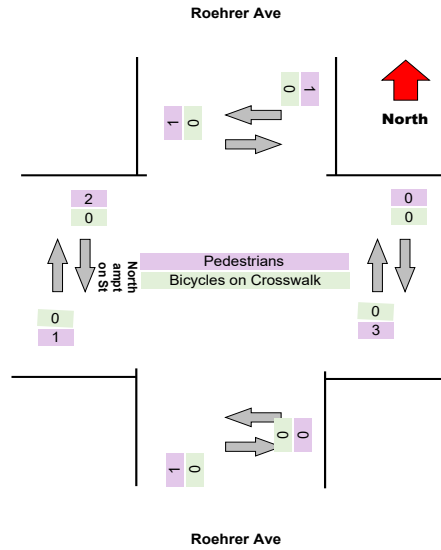
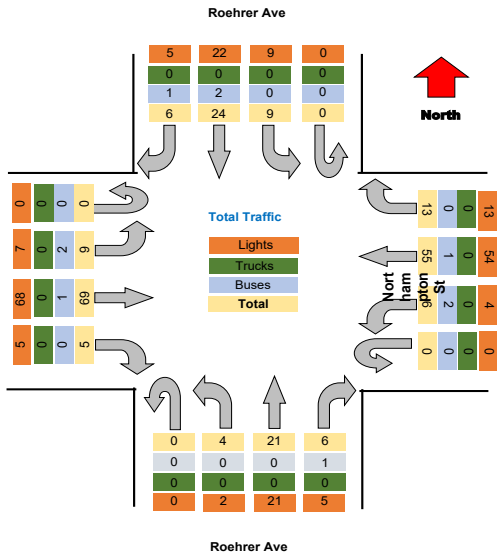





Project : VBH Malta NY  
 Site : Site 4  
 Location : 42.948550, -73.790036  
 Survey Date : 2021-04-28, Wednesday

### Turning Movement Data Plot

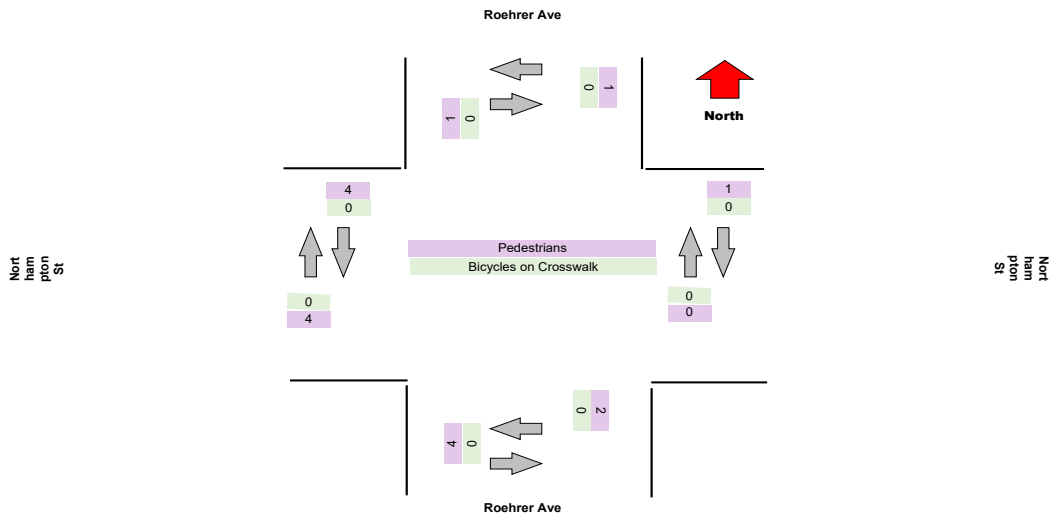
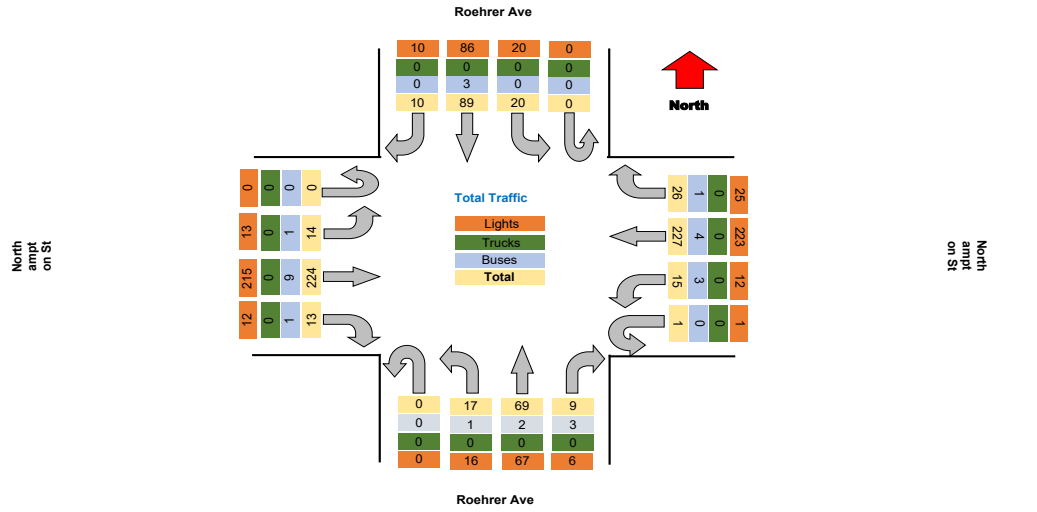

**Turning Movement Peak Hour Data (AM)**

7:30:00 AM

Leg Direction	Roehrer Ave						Northampton St						Roehrer Ave						Northampton St						Total				
	Southbound			Westbound			Northbound			Eastbound			Northbound			Eastbound													
Start Time	Right	Thru	Left	U-Turn	App Total	Peds CW	Peds CCW	Right	Thru	Left	U-Turn	App Total	Peds CW	Peds CCW	Right	Thru	Left	U-Turn	App Total	Peds CW	Peds CCW	Right	Thru	Left	U-Turn	App Total	Peds CW	Peds CCW	
7:30:00 AM	0	3	1	0	4	0	0	1	11	1	0	14	0	0	0	3	1	0	4	0	0	0	9	0	0	9	0	0	31
7:45:00 AM	0	4	2	0	6	0	0	2	15	1	0	18	0	0	2	3	0	0	5	0	0	1	17	0	0	18	1	0	47
8:00:00 AM	0	4	1	0	5	0	0	1	17	0	0	18	1	0	0	3	2	0	6	0	2	0	11	0	0	11	1	0	40
8:15:00 AM	0	2	0	0	2	0	0	0	24	1	0	25	0	0	0	4	1	0	5	1	0	1	16	0	0	19	0	0	51
Grand Total	0	13	4	0	17	0	0	4	67	3	0	75	1	0	2	13	4	0	20	1	2	2	55	0	0	57	2	0	169
% Approach	0.0%	76.5%	23.5%	0.0%	0.0%	0.0%	0.0%	5.3%	88.3%	4.0%	0.0%	0.0%	0.0%	0.0%	10.0%	65.0%	20.0%	0.0%	0.0%	0.0%	0.0%	3.5%	95.5%	0.0%	0.0%	0.0%	0.0%	0.0%	0.0%
% Total	0.0%	7.7%	2.4%	0.0%	10.1%	0.0%	0.0%	2.4%	39.6%	1.8%	0.0%	44.4%	0.0%	0.0%	1.2%	7.7%	2.4%	0.0%	11.8%	0.0%	0.0%	1.2%	32.5%	0.0%	0.0%	33.7%	0.0%	0.0%	6.5%
PHF	0.000	0.813	0.500	0.000	0.708	0.000	0.000	0.500	0.698	0.750	0.000	0.750	0.000	0.000	0.250	0.813	0.500	0.000	0.833	0.000	0.000	0.500	0.764	0.000	0.000	0.750	0.000	0.000	0.828
Lights	0	12	4	0	16	0	0	4	65	2	0	71	0	0	1	13	3	0	17	0	0	2	50	0	0	52	0	0	156
% Lights	0.0%	92.3%	100.0%	0.0%	94.1%	0.0%	0.0%	100.0%	97.0%	66.7%	0.0%	94.7%	0.0%	0.0%	50.0%	100.0%	75.0%	0.0%	85.0%	0.0%	0.0%	100.0%	90.9%	0.0%	0.0%	91.2%	0.0%	0.0%	92.3%
Trucks	0	0	0	0	0	0	0	0	0	0	0	0	0	0	0	0	0	0	0	0	0	0	0	0	0	0	0	0	0
% Trucks	0.0%	0.0%	0.0%	0.0%	0.0%	0.0%	0.0%	0.0%	0.0%	0.0%	0.0%	0.0%	0.0%	0.0%	0.0%	0.0%	0.0%	0.0%	0.0%	0.0%	0.0%	0.0%	0.0%	0.0%	0.0%	0.0%	0.0%	0.0%	0.0%
Buses	0	1	0	0	1	0	0	0	2	1	0	3	0	0	1	0	1	0	2	0	0	0	5	0	0	5	0	0	11
% Buses	0.0%	7.7%	0.0%	0.0%	0.0%	0.0%	0.0%	0.0%	3.0%	33.3%	0.0%	0.0%	0.0%	0.0%	50.0%	0.0%	25.0%	0.0%	0.0%	0.0%	0.0%	0.0%	9.1%	0.0%	0.0%	0.0%	0.0%	0.0%	6.5%
Pedestrians	0	0	0	0	0	0	1	0	0	0	0	0	1	2	0	0	0	0	0	0	0	0	0	0	0	0	2	0	0
% Pedestrians	0.0%	0.0%	0.0%	0.0%	0.0%	100.0%	100.0%	0.0%	0.0%	0.0%	0.0%	0.0%	100.0%	100.0%	0.0%	0.0%	0.0%	0.0%	0.0%	0.0%	100.0%	100.0%	0.0%	0.0%	0.0%	0.0%	100.0%	0.0%	0.0%
Bicycles on Crosswalk	0	0	0	0	0	0	0	0	0	0	0	0	0	0	0	0	0	0	0	0	0	0	0	0	0	0	0	0	0
% Bicycles on Crosswalk	0.0%	0.0%	0.0%	0.0%	0.0%	0.0%	0.0%	0.0%	0.0%	0.0%	0.0%	0.0%	0.0%	0.0%	0.0%	0.0%	0.0%	0.0%	0.0%	0.0%	0.0%	0.0%	0.0%	0.0%	0.0%	0.0%	0.0%	0.0%	0.0%

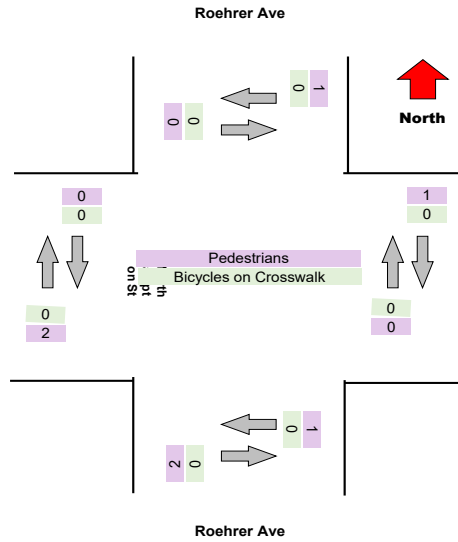
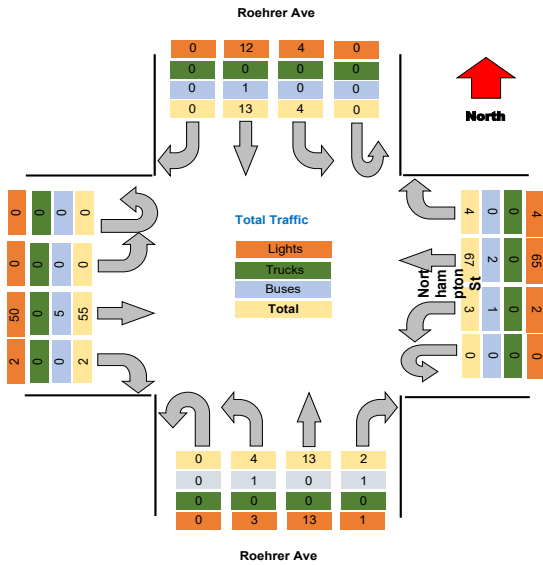

### Turning Movement Peak Hour Data (PM)

4:30:00 PM

Leg Direction	Roehrer Ave					Northampton St					Roehrer Ave					Northampton St					Total								
	Southbound					Westbound					Northbound					Eastbound													
Start Time	Right	Thru	Left	U-Turn	App Total	Peds CW	Peds CCW	Right	Thru	Left	U-Turn	App Total	Peds CW	Peds CCW	Right	Thru	Left	U-Turn	App Total	Peds CW	Peds CCW	Right	Thru	Left	U-Turn	App Total	Peds CW	Peds CCW	
4:30:00 PM	0	9	3	0	12	0	0	2	21	0	0	23	0	0	0	8	1	0	9	0	0	1	22	0	0	23	0	0	67
4:45:00 PM	1	5	2	0	8	0	0	5	21	1	0	27	0	0	1	5	3	0	9	0	0	2	21	2	0	25	0	0	69
5:00:00 PM	1	10	2	0	13	0	0	3	17	2	0	22	0	0	0	6	0	0	6	0	0	2	20	1	0	23	0	0	64
5:15:00 PM	0	9	1	0	10	0	0	2	16	2	0	20	0	0	0	3	1	0	4	0	0	0	18	2	0	20	1	0	54
<b>Grand Total</b>	<b>2</b>	<b>33</b>	<b>8</b>	<b>0</b>	<b>43</b>	<b>0</b>	<b>0</b>	<b>12</b>	<b>75</b>	<b>5</b>	<b>0</b>	<b>92</b>	<b>0</b>	<b>0</b>	<b>1</b>	<b>22</b>	<b>5</b>	<b>0</b>	<b>28</b>	<b>0</b>	<b>0</b>	<b>5</b>	<b>81</b>	<b>5</b>	<b>0</b>	<b>91</b>	<b>1</b>	<b>0</b>	<b>254</b>
% Approach	4.7%	76.7%	18.6%	0.0%	0.0%	0.0%	0.0%	13.0%	81.5%	5.4%	0.0%	0.0%	0.0%	0.0%	3.6%	78.6%	17.9%	0.0%	0.0%	0.0%	0.0%	5.5%	89.0%	5.5%	0.0%	0.0%	0.0%	0.0%	0.0%
% Total	0.8%	13.0%	3.1%	0.0%	16.9%	0.0%	0.0%	4.7%	29.5%	2.0%	0.0%	36.2%	0.0%	0.0%	0.4%	8.7%	2.0%	0.0%	11.0%	0.0%	0.0%	2.0%	31.9%	2.0%	0.0%	35.8%	0.0%	0.0%	0.0%
PHF	0.500	0.825	0.667	0.000	0.827	0.000	0.000	0.600	0.893	0.625	0.000	0.852	0.000	0.000	0.250	0.688	0.417	0.000	0.778	0.000	0.000	0.625	0.920	0.625	0.000	0.910	0.000	0.000	0.920
Lights	2	32	8	0	42	0	0	11	73	4	0	88	0	0	1	22	5	0	28	0	0	5	80	5	0	90	0	0	248
% Lights	100.0%	97.0%	100.0%	0.0%	97.7%	0.0%	0.0%	81.7%	97.3%	80.0%	0.0%	95.7%	0.0%	0.0%	100.0%	100.0%	100.0%	0.0%	100.0%	0.0%	0.0%	100.0%	98.8%	100.0%	0.0%	98.9%	0.0%	0.0%	97.6%
Trucks	0	0	0	0	0	0	0	0	0	0	0	0	0	0	0	0	0	0	0	0	0	0	0	0	0	0	0	0	0
% Trucks	0.0%	0.0%	0.0%	0.0%	0.0%	0.0%	0.0%	0.0%	0.0%	0.0%	0.0%	0.0%	0.0%	0.0%	0.0%	0.0%	0.0%	0.0%	0.0%	0.0%	0.0%	0.0%	0.0%	0.0%	0.0%	0.0%	0.0%	0.0%	0.0%
Buses	0	1	0	0	1	0	0	1	2	1	0	4	0	0	0	0	0	0	0	0	0	1	0	0	0	1	0	0	6
% Buses	0.0%	3.0%	0.0%	0.0%	0.0%	0.0%	0.0%	8.3%	2.7%	20.0%	0.0%	0.0%	0.0%	0.0%	0.0%	0.0%	0.0%	0.0%	0.0%	0.0%	0.0%	1.2%	0.0%	0.0%	0.0%	0.0%	0.0%	2.4%	
Pedestrians	0	0	0	0	0	0	0	0	0	0	0	0	0	0	0	0	0	0	1	0	0	0	0	0	0	0	1	0	0
% Pedestrians	0.0%	0.0%	0.0%	0.0%	0.0%	0.0%	0.0%	0.0%	0.0%	0.0%	0.0%	0.0%	0.0%	0.0%	0.0%	0.0%	0.0%	0.0%	0.0%	0.0%	0.0%	100.0%	0.0%	0.0%	0.0%	0.0%	100.0%	0.0%	0.0%
Bicycles on Crosswalk	0	0	0	0	0	0	0	0	0	0	0	0	0	0	0	0	0	0	0	0	0	0	0	0	0	0	0	0	0
% Bicycles on Crosswalk	0.0%	0.0%	0.0%	0.0%	0.0%	0.0%	0.0%	0.0%	0.0%	0.0%	0.0%	0.0%	0.0%	0.0%	0.0%	0.0%	0.0%	0.0%	0.0%	0.0%	0.0%	0.0%	0.0%	0.0%	0.0%	0.0%	0.0%	0.0%	0.0%

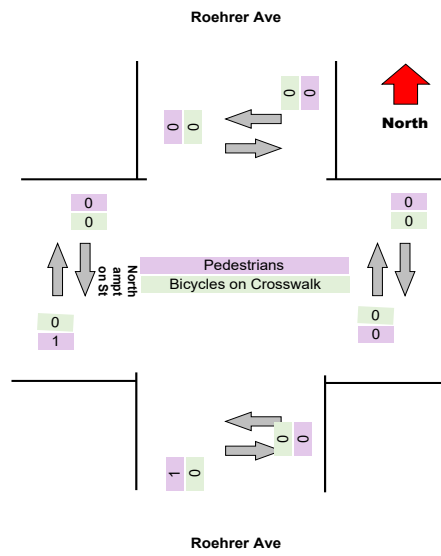
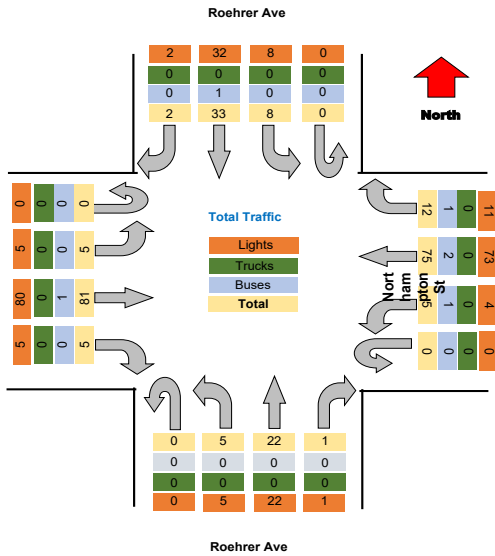



Project : VBH Malta NY  
 Site : Site 4  
 Location : 42.948550, -73.790036  
 Survey Date : 2021-04-28, Wednesday

### Turning Movement Data Plot

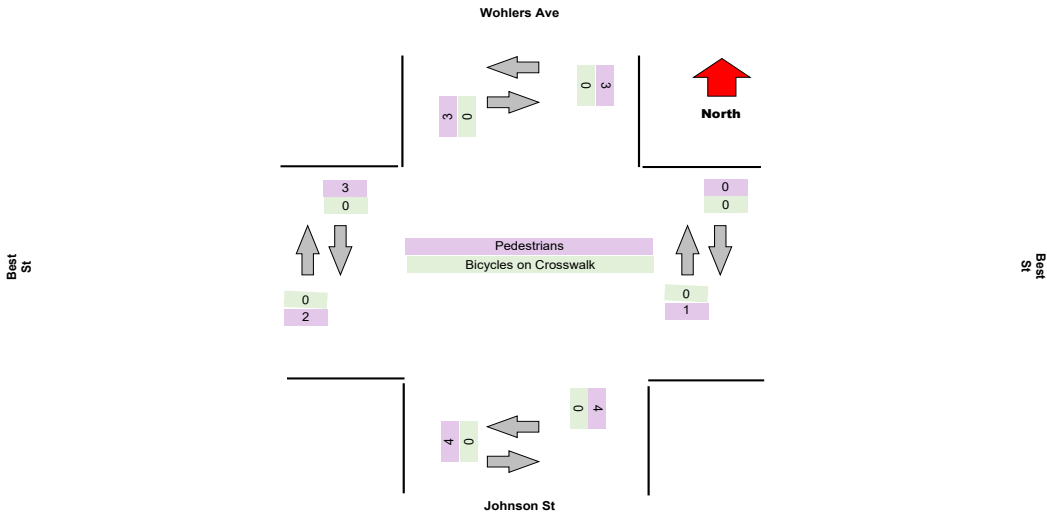
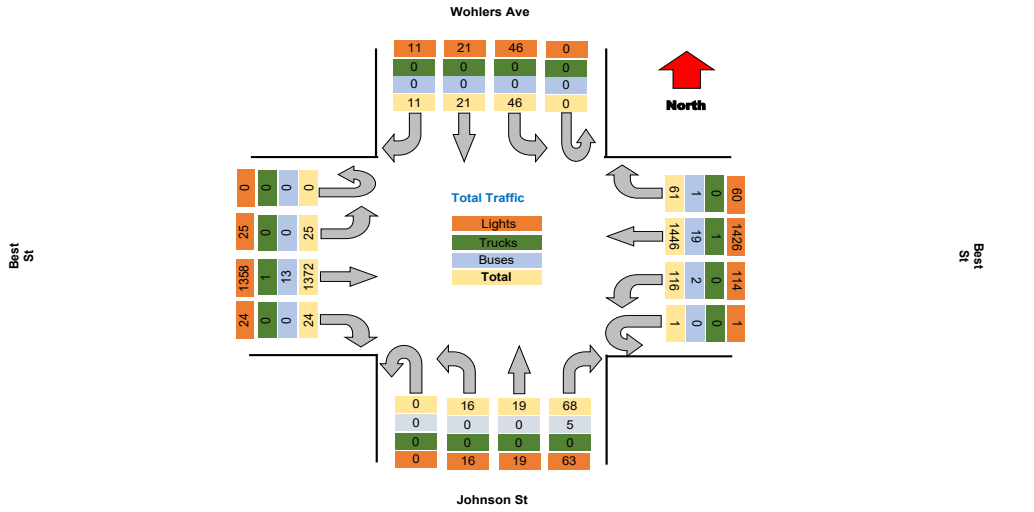

Project : VBH Malta NY  
Site : Site 4  
Location : 42.948550, -73.790036

TSTData.com

Survey Date : 2021-04-28, Wednesday

### Turning Movement Peak Hour Data (AM)

7:30:00 AM

Leg Direction	Wohlers Ave						Best St						Johnson St						Best St						Total			
	Southbound			Westbound			Northbound			Eastbound			Northbound			Eastbound												
Start Time	Right	Thru	Left	U-Turn	App Total	Peds CW	Peds CCW	Right	Thru	Left	U-Turn	App Total	Peds CW	Peds CCW	Right	Thru	Left	U-Turn	App Total	Peds CW	Peds CCW	Right	Thru	Left	U-Turn	App Total	Peds CW	Peds CCW
7:30:00 AM	0	0	3	0	3	0	0	1	91	4	0	96	0	0	2	0	0	0	2	0	0	74	0	0	0	74	0	0
7:45:00 AM	0	2	5	0	7	0	0	1	107	10	0	118	0	0	12	1	2	0	15	0	0	2	65	3	0	70	0	0
8:00:00 AM	0	0	1	0	1	0	1	1	89	10	0	101	0	0	8	1	0	0	9	1	0	2	57	0	0	59	0	0
8:15:00 AM	1	0	1	0	2	0	0	4	101	14	0	115	0	0	1	1	1	0	3	0	1	0	59	0	0	59	0	0
<b>Grand Total</b>	<b>1</b>	<b>2</b>	<b>10</b>	<b>0</b>	<b>13</b>	<b>0</b>	<b>1</b>	<b>7</b>	<b>388</b>	<b>38</b>	<b>0</b>	<b>424</b>	<b>0</b>	<b>0</b>	<b>23</b>	<b>3</b>	<b>3</b>	<b>0</b>	<b>29</b>	<b>1</b>	<b>1</b>	<b>5</b>	<b>254</b>	<b>3</b>	<b>0</b>	<b>257</b>	<b>3</b>	<b>0</b>
% Approach	7.7%	15.4%	76.9%	0.0%	0.0%	0.0%	0.0%	1.6%	88.4%	8.8%	0.0%	0.0%	0.0%	0.0%	79.3%	10.3%	10.3%	0.0%	0.0%	0.0%	0.0%	1.9%	96.9%	1.1%	0.0%	0.0%	0.0%	0.0%
% Total	0.1%	0.3%	1.4%	0.0%	1.8%	0.0%	0.0%	0.9%	52.6%	5.1%	0.0%	58.8%	0.0%	0.0%	3.1%	0.4%	0.4%	0.0%	3.9%	0.0%	0.0%	0.7%	34.4%	0.4%	0.0%	35.5%	0.0%	0.0%
PHF	0.250	0.250	0.500	0.000	0.464	0.000	0.000	0.438	0.907	0.679	0.000	0.912	0.000	0.000	0.479	0.750	0.375	0.000	0.483	0.000	0.000	0.625	0.870	0.250	0.000	0.885	0.000	0.000
Lights	1	2	10	0	13	0	0	7	379	36	0	422	0	0	21	3	3	0	27	0	0	5	248	3	0	256	0	0
% Lights	100.0%	100.0%	100.0%	0.0%	100.0%	0.0%	0.0%	100.0%	97.7%	94.7%	0.0%	97.2%	0.0%	0.0%	81.3%	100.0%	100.0%	0.0%	93.1%	0.0%	0.0%	100.0%	97.6%	100.0%	0.0%	97.7%	0.0%	0.0%
Trucks	0	0	0	0	0	0	0	0	0	0	0	0	0	0	0	0	0	0	0	0	0	0	1	0	0	1	0	0
% Trucks	0.0%	0.0%	0.0%	0.0%	0.0%	0.0%	0.0%	0.0%	0.0%	0.0%	0.0%	0.0%	0.0%	0.0%	0.0%	0.0%	0.0%	0.0%	0.0%	0.0%	0.0%	0.0%	0.4%	0.0%	0.0%	0.4%	0.0%	0.0%
Buses	0	0	0	0	0	0	0	0	9	2	0	11	0	0	2	0	0	0	2	0	0	0	5	0	0	5	0	0
% Buses	0.0%	0.0%	0.0%	0.0%	0.0%	0.0%	0.0%	0.0%	2.3%	5.3%	0.0%	0.0%	0.0%	0.0%	8.7%	0.0%	0.0%	0.0%	0.0%	0.0%	0.0%	0.0%	2.0%	0.0%	0.0%	0.0%	0.0%	0.0%
Pedestrians	0	0	0	0	0	0	1	0	0	0	0	0	0	0	0	1	1	0	0	0	0	0	0	0	0	0	0	0
% Pedestrians	0.0%	0.0%	0.0%	0.0%	0.0%	0.0%	100.0%	0.0%	0.0%	0.0%	0.0%	0.0%	0.0%	0.0%	0.0%	100.0%	100.0%	0.0%	0.0%	100.0%	100.0%	0.0%	0.0%	0.0%	0.0%	0.0%	0.0%	0.0%
Bicycles on Crosswalk	0	0	0	0	0	0	0	0	0	0	0	0	0	0	0	0	0	0	0	0	0	0	0	0	0	0	0	0
% Bicycles on Crosswalk	0.0%	0.0%	0.0%	0.0%	0.0%	0.0%	0.0%	0.0%	0.0%	0.0%	0.0%	0.0%	0.0%	0.0%	0.0%	0.0%	0.0%	0.0%	0.0%	0.0%	0.0%	0.0%	0.0%	0.0%	0.0%	0.0%	0.0%	0.0%

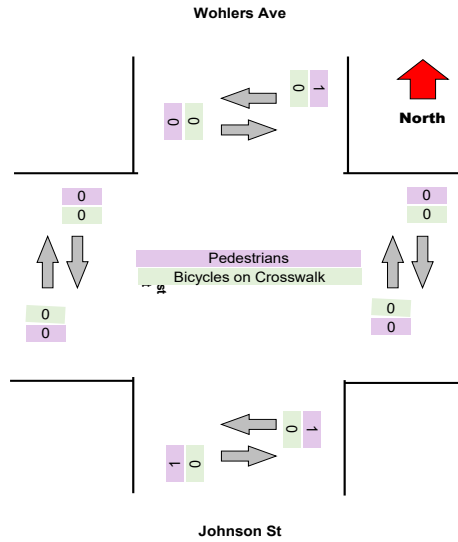
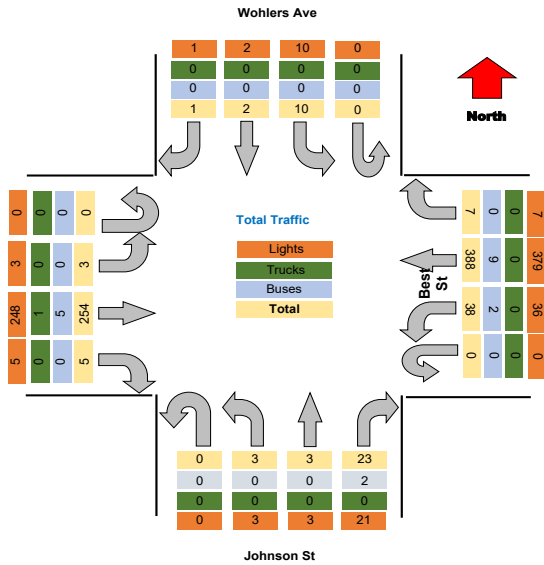

**Turning Movement Peak Hour Data (PM)**

4:15:00 PM

Leg Direction	Wohlers Ave						Best St						Johnson St						Best St						Total					
	Southbound			Westbound			Northbound			Eastbound			Northbound			Eastbound														
Start Time	Right	Thru	Left	U-Turn	App Total	Peds CW	Peds CCW	Right	Thru	Left	U-Turn	App Total	Peds CW	Peds CCW	Right	Thru	Left	U-Turn	App Total	Peds CW	Peds CCW	Right	Thru	Left	U-Turn	App Total	Peds CW	Peds CCW		
4:15:00 PM	0	3	1	0	4	1	0	6	92	10	0	108	0	0	2	1	1	0	4	0	1	8	124	3	0	135	0	0	251	
4:30:00 PM	2	3	4	0	9	1	0	8	98	19	0	125	0	0	19	0	1	0	20	0	1	2	124	3	0	129	2	0	283	
4:45:00 PM	0	2	5	0	7	0	0	2	94	12	0	108	0	0	4	4	2	0	10	0	0	1	107	5	0	113	0	0	238	
5:00:00 PM	2	2	1	0	5	0	0	6	88	5	0	109	0	0	2	2	1	0	5	0	0	0	144	3	0	144	0	0	283	
<b>Grand Total</b>	<b>4</b>	<b>10</b>	<b>11</b>	<b>0</b>	<b>25</b>	<b>2</b>	<b>0</b>	<b>22</b>	<b>382</b>	<b>46</b>	<b>0</b>	<b>450</b>	<b>0</b>	<b>0</b>	<b>27</b>	<b>7</b>	<b>5</b>	<b>0</b>	<b>39</b>	<b>0</b>	<b>2</b>	<b>11</b>	<b>493</b>	<b>14</b>	<b>0</b>	<b>521</b>	<b>2</b>	<b>0</b>	<b>1035</b>	
% Approach	16.0%	40.0%	44.0%	0.0%	0.0%	0.0%	0.0%	4.9%	84.9%	10.2%	0.0%	0.0%	0.0%	0.0%	89.2%	17.9%	12.8%	0.0%	0.0%	0.0%	0.0%	2.1%	95.2%	2.7%	0.0%	0.0%	0.0%	0.0%	0.0%	
% Total	0.4%	1.0%	1.1%	0.0%	2.4%	0.0%	0.0%	2.1%	36.9%	4.4%	0.0%	43.5%	0.0%	0.0%	2.6%	0.7%	0.5%	0.0%	3.8%	0.0%	0.0%	1.1%	47.9%	1.4%	0.0%	50.3%	0.0%	0.0%	0.0%	
PHF	0.500	0.833	0.550	0.000	0.694	0.000	0.000	0.688	0.974	0.605	0.000	0.900	0.000	0.000	0.355	0.438	0.625	0.000	0.488	0.000	0.000	0.344	0.879	0.700	0.000	0.905	0.000	0.000	0.914	
Lights	4	10	11	0	25	0	0	21	379	46	0	446	0	0	25	7	5	0	37	0	0	11	493	14	0	518	0	0	1026	
% Lights	100.0%	100.0%	100.0%	0.0%	100.0%	0.0%	0.0%	95.5%	99.2%	100.0%	0.0%	99.1%	0.0%	0.0%	92.6%	100.0%	100.0%	0.0%	94.9%	0.0%	0.0%	100.0%	99.4%	100.0%	0.0%	99.4%	0.0%	0.0%	99.1%	
Trucks	0	0	0	0	0	0	0	0	0	0	0	0	0	0	0	0	0	0	0	0	0	0	0	0	0	0	0	0	0	
% Trucks	0.0%	0.0%	0.0%	0.0%	0.0%	0.0%	0.0%	0.0%	0.0%	0.0%	0.0%	0.0%	0.0%	0.0%	0.0%	0.0%	0.0%	0.0%	0.0%	0.0%	0.0%	0.0%	0.0%	0.0%	0.0%	0.0%	0.0%	0.0%	0.0%	
Buses	0	0	0	0	0	0	0	1	3	0	0	4	0	0	2	0	0	0	2	0	0	0	3	0	0	3	0	0	9	
% Buses	0.0%	0.0%	0.0%	0.0%	0.0%	0.0%	0.0%	4.5%	0.8%	0.0%	0.0%	0.9%	0.0%	0.0%	7.4%	0.0%	0.0%	0.0%	0.0%	0.0%	0.0%	0.0%	0.6%	0.0%	0.0%	0.0%	0.0%	0.0%	0.9%	
Pedestrians	0	0	0	0	0	2	1	0	0	0	0	0	0	0	0	0	0	0	0	0	2	0	0	0	0	0	2	0	0	
% Pedestrians	0.0%	0.0%	0.0%	0.0%	0.0%	100.0%	100.0%	0.0%	0.0%	0.0%	0.0%	0.0%	0.0%	0.0%	0.0%	0.0%	0.0%	0.0%	0.0%	0.0%	100.0%	0.0%	0.0%	0.0%	0.0%	0.0%	0.0%	100.0%	0.0%	0.0%
Bicycles on Crosswalk	0	0	0	0	0	0	0	0	0	0	0	0	0	0	0	0	0	0	0	0	0	0	0	0	0	0	0	0	0	
% Bicycles on Crosswalk	0.0%	0.0%	0.0%	0.0%	0.0%	0.0%	0.0%	0.0%	0.0%	0.0%	0.0%	0.0%	0.0%	0.0%	0.0%	0.0%	0.0%	0.0%	0.0%	0.0%	0.0%	0.0%	0.0%	0.0%	0.0%	0.0%	0.0%	0.0%	0.0%	

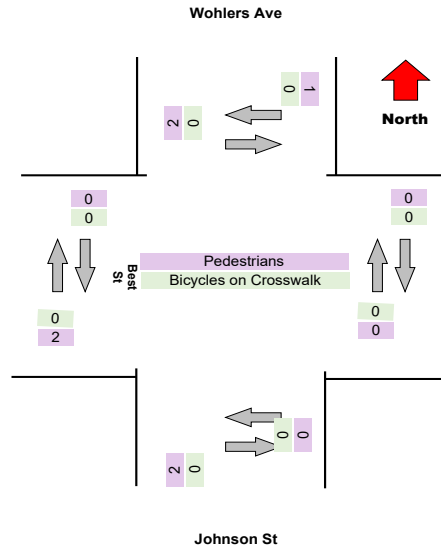
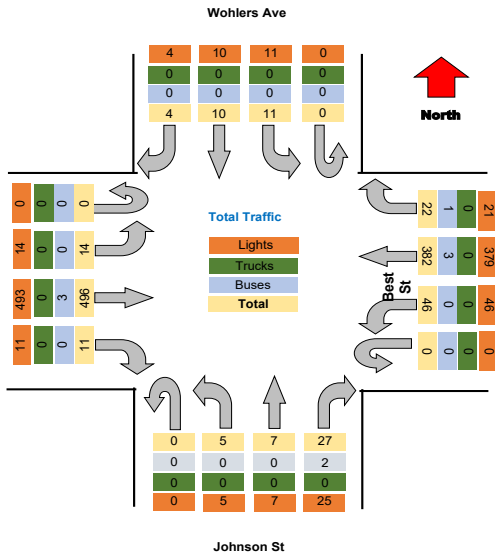





Project : VBH Malta NY  
 Site : Site 4  
 Location : 42.948550, -73.790036  
 Survey Date : 2021-04-28, Wednesday

### Turning Movement Data Plot

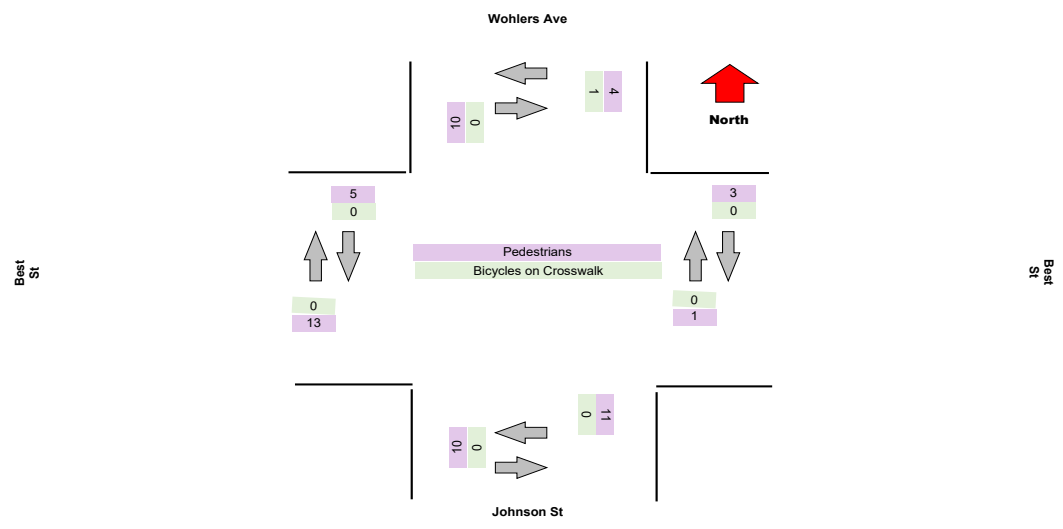
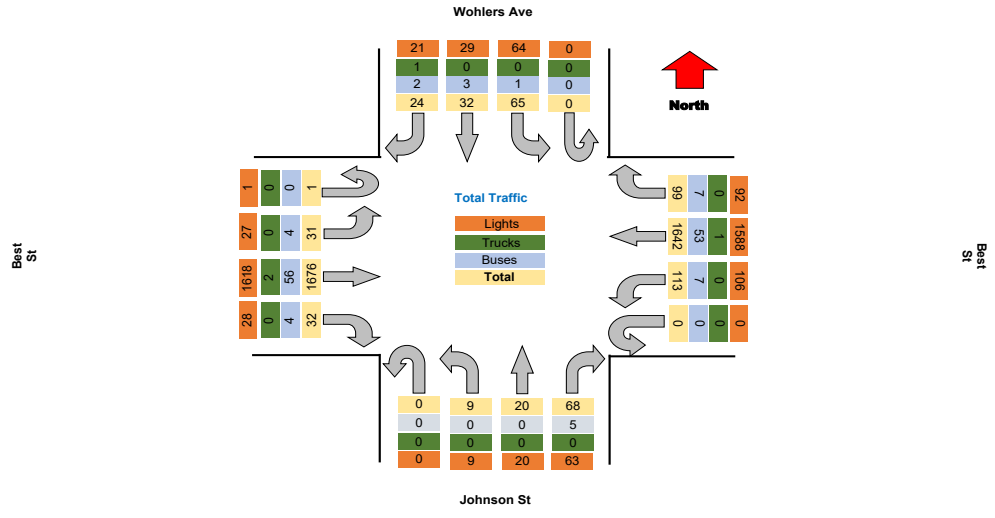

Project : VBH Malta NY  
Site : Site 4  
Location : 42.948550, -73.790036

TSTData.com

Survey Date : 2021-04-28, Wednesday

**Turning Movement Peak Hour Data (AM)**

7:30:00 AM

Leg Direction	Wohlers Ave					Best St					Johnson St					Best St					Total									
	Right	Thru	Left	U-Turn	App Total	Peds CW	Peds CCW	Right	Thru	Left	U-Turn	App Total	Peds CW	Peds CCW	Right	Thru	Left	U-Turn	App Total	Peds CW		Peds CCW								
7:30:00 AM	1	0	7	0	8	0	0	6	101	4	0	111	0	0	5	1	0	0	6	0	0	108	0	0	109	1	0	234		
7:45:00 AM	2	5	5	0	12	0	0	5	148	15	0	168	0	0	11	3	1	0	15	1	1	2	121	0	0	123	0	0	318	
8:00:00 AM	0	1	1	0	2	0	0	6	145	12	0	163	0	0	7	0	0	0	7	0	0	3	120	1	0	124	0	0	296	
8:15:00 AM	1	2	3	0	6	0	0	4	108	7	0	129	0	0	0	0	1	0	1	1	2	0	74	2	0	76	0	0	293	
<b>Grand Total</b>	<b>4</b>	<b>8</b>	<b>16</b>	<b>0</b>	<b>28</b>	<b>0</b>	<b>0</b>	<b>21</b>	<b>502</b>	<b>38</b>	<b>0</b>	<b>562</b>	<b>0</b>	<b>0</b>	<b>23</b>	<b>4</b>	<b>2</b>	<b>0</b>	<b>29</b>	<b>2</b>	<b>3</b>	<b>6</b>	<b>423</b>	<b>3</b>	<b>0</b>	<b>432</b>	<b>1</b>	<b>0</b>	<b>1051</b>	
% Approach	14.3%	28.6%	57.1%	0.0%	0.0%	0.0%	0.0%	3.7%	89.3%	6.8%	0.0%	0.0%	0.0%	0.0%	79.3%	13.8%	6.9%	0.0%	0.0%	0.0%	0.0%	1.4%	97.9%	0.7%	0.0%	0.0%	0.0%	0.0%	0.0%	
% Total	0.4%	0.8%	1.5%	0.0%	2.7%	0.0%	0.0%	2.0%	47.8%	3.6%	0.0%	63.5%	0.0%	0.0%	2.2%	0.4%	0.2%	0.0%	2.6%	0.0%	0.0%	0.6%	40.2%	0.3%	0.0%	41.1%	0.0%	0.0%	0.0%	
PHF	0.500	0.400	0.571	0.000	0.583	0.000	0.000	0.875	0.848	0.633	0.000	0.836	0.000	0.000	0.523	0.333	0.500	0.000	0.483	0.000	0.000	0.500	0.874	0.375	0.000	0.871	0.000	0.000	0.826	
Lights	4	8	15	0	27	0	0	19	482	34	0	535	0	0	21	4	2	0	27	0	0	5	412	3	0	420	0	0	1009	
% Trucks	100.0%	100.0%	93.8%	0.0%	96.4%	0.0%	0.0%	80.5%	96.0%	89.5%	0.0%	95.2%	0.0%	0.0%	81.3%	100.0%	100.0%	0.0%	93.1%	0.0%	0.0%	83.3%	97.4%	100.0%	0.0%	97.2%	0.0%	0.0%	96.0%	
% Buses	0.0%	0.0%	0.0%	0.0%	0.0%	0.0%	0.0%	0.0%	0.2%	0.0%	0.0%	0.2%	0.0%	0.0%	0.0%	0.0%	0.0%	0.0%	0.0%	0.0%	0.0%	0.0%	0.2%	0.0%	0.0%	0.2%	0.0%	0.0%	0.2%	
Pedestrians	0	0	0	0	0	0	0	0	0	0	0	0	0	0	0	0	0	0	0	2	3	0	0	0	0	0	0	1	0	0
% Pedestrians	0.0%	0.0%	0.0%	0.0%	0.0%	0.0%	100.0%	0.0%	0.0%	0.0%	0.0%	0.0%	0.0%	0.0%	0.0%	0.0%	0.0%	0.0%	0.0%	0.0%	100.0%	100.0%	0.0%	0.0%	0.0%	0.0%	0.0%	100.0%	0.0%	0.0%
Bicycles on Crosswalk	0	0	0	0	0	0	0	0	0	0	0	0	0	0	0	0	0	0	0	0	0	0	0	0	0	0	0	0	0	
% Bicycles on Crosswalk	0.0%	0.0%	0.0%	0.0%	0.0%	0.0%	0.0%	0.0%	0.0%	0.0%	0.0%	0.0%	0.0%	0.0%	0.0%	0.0%	0.0%	0.0%	0.0%	0.0%	0.0%	0.0%	0.0%	0.0%	0.0%	0.0%	0.0%	0.0%	0.0%	

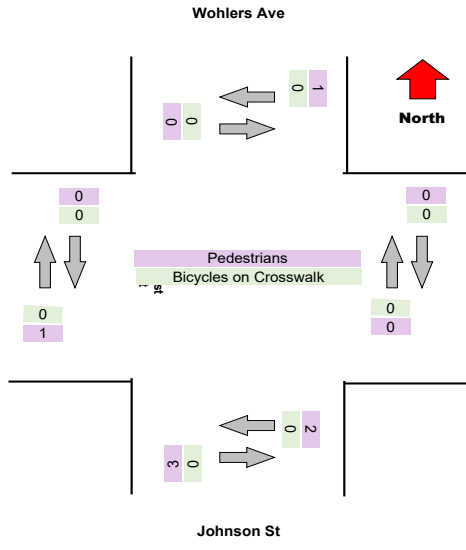
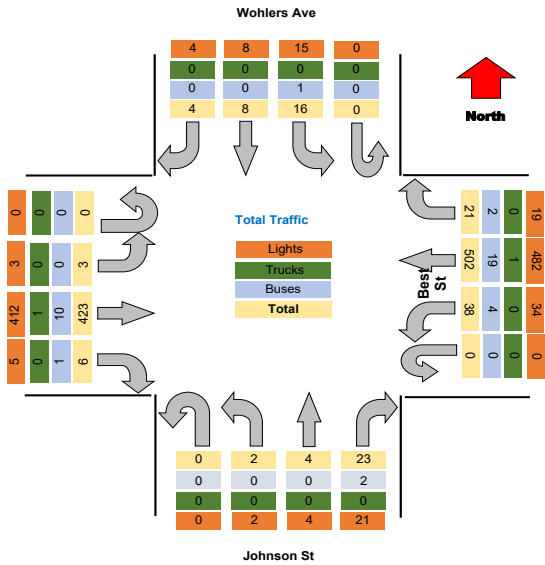

**Turning Movement Peak Hour Data (PM)**

4:15:00 PM

Leg Direction	Wohlers Ave					Best St					Johnson St					Best St					Total									
	Southbound					Westbound					Northbound					Eastbound														
Start Time	Right	Thru	Left	U-Turn	App Total	Peds CW	Peds CCW	Right	Thru	Left	U-Turn	App Total	Peds CW	Peds CCW	Right	Thru	Left	U-Turn	App Total	Peds CW	Peds CCW	Right	Thru	Left	U-Turn	App Total	Peds CW	Peds CCW		
4:15:00 PM	4	7	3	0	14	2	2	10	116	13	0	139	3	1	3	3	0	0	6	0	0	1	142	2	0	145	0	0	304	
4:30:00 PM	3	4	6	0	13	0	0	7	81	9	0	97	0	0	14	4	1	0	19	2	0	3	168	5	0	176	4	2	305	
4:45:00 PM	2	4	0	0	6	0	0	7	102	8	0	117	0	0	8	2	2	0	12	0	4	5	117	3	0	125	0	0	260	
5:00:00 PM	1	4	7	0	9	1	0	8	95	4	0	107	0	0	3	1	0	0	4	0	1	2	136	3	1	142	0	0	262	
<b>Grand Total</b>	<b>10</b>	<b>16</b>	<b>16</b>	<b>0</b>	<b>42</b>	<b>3</b>	<b>2</b>	<b>32</b>	<b>394</b>	<b>34</b>	<b>0</b>	<b>460</b>	<b>3</b>	<b>1</b>	<b>28</b>	<b>10</b>	<b>3</b>	<b>0</b>	<b>41</b>	<b>2</b>	<b>5</b>	<b>11</b>	<b>563</b>	<b>13</b>	<b>1</b>	<b>586</b>	<b>4</b>	<b>2</b>	<b>1131</b>	
% Approach	23.8%	38.1%	38.1%	0.0%	0.0%	0.0%	0.0%	7.0%	85.7%	7.4%	0.0%	0.0%	0.0%	0.0%	68.3%	24.4%	7.3%	0.0%	0.0%	0.0%	0.0%	1.9%	95.7%	2.2%	0.2%	0.0%	0.0%	0.0%	0.0%	
% Total	0.9%	1.4%	1.4%	0.0%	3.7%	0.0%	0.0%	2.8%	34.8%	3.0%	0.0%	40.7%	0.0%	0.0%	2.5%	0.9%	0.3%	0.0%	3.6%	0.0%	0.0%	1.0%	49.8%	1.1%	0.1%	52.0%	0.0%	0.0%	0.0%	
PHF	0.625	0.571	0.571	0.000	0.750	0.000	0.000	0.800	0.849	0.654	0.000	0.827	0.000	0.000	0.500	0.625	0.375	0.000	0.539	0.000	0.000	0.550	0.838	0.650	0.250	0.835	0.000	0.000	0.927	
Lights	9	13	16	0	38	0	0	30	384	33	0	447	0	0	26	10	3	0	39	0	0	10	546	12	1	569	0	0	1093	
% Lights	80.0%	81.3%	100.0%	0.0%	90.5%	0.0%	0.0%	83.8%	97.5%	97.1%	0.0%	97.2%	0.0%	0.0%	82.9%	100.0%	100.0%	0.0%	95.1%	0.0%	0.0%	90.9%	97.0%	92.3%	100.0%	96.8%	0.0%	0.0%	96.6%	
Trucks	0	0	0	0	0	0	0	0	0	0	0	0	0	0	0	0	0	0	0	0	0	0	0	0	0	0	0	0	0	0
% Trucks	0.0%	0.0%	0.0%	0.0%	0.0%	0.0%	0.0%	0.0%	0.0%	0.0%	0.0%	0.0%	0.0%	0.0%	0.0%	0.0%	0.0%	0.0%	0.0%	0.0%	0.0%	0.0%	0.0%	0.0%	0.0%	0.0%	0.0%	0.0%	0.0%	0.0%
Buses	1	3	0	0	4	0	0	2	10	1	0	13	0	0	2	0	0	0	2	0	0	1	17	1	0	19	0	0	38	
% Buses	10.0%	18.8%	0.0%	0.0%	0.0%	0.0%	0.0%	6.3%	2.5%	2.9%	0.0%	0.0%	0.0%	0.0%	7.1%	0.0%	0.0%	0.0%	0.0%	0.0%	0.0%	9.1%	3.0%	7.7%	0.0%	0.0%	0.0%	0.0%	3.4%	
Pedestrians	0	0	0	0	0	3	2	0	0	0	0	3	1	1	0	0	0	0	0	2	5	0	0	0	0	0	4	2	10	
% Pedestrians	0.0%	0.0%	0.0%	0.0%	0.0%	100.0%	100.0%	0.0%	0.0%	0.0%	0.0%	0.0%	100.0%	100.0%	0.0%	0.0%	0.0%	0.0%	0.0%	0.0%	100.0%	100.0%	0.0%	0.0%	0.0%	0.0%	0.0%	100.0%	100.0%	0.0%
Bicycles on Crosswalk	0	0	0	0	0	0	0	0	0	0	0	0	0	0	0	0	0	0	0	0	0	0	0	0	0	0	0	0	0	
% Bicycles on Crosswalk	0.0%	0.0%	0.0%	0.0%	0.0%	0.0%	0.0%	0.0%	0.0%	0.0%	0.0%	0.0%	0.0%	0.0%	0.0%	0.0%	0.0%	0.0%	0.0%	0.0%	0.0%	0.0%	0.0%	0.0%	0.0%	0.0%	0.0%	0.0%	0.0%	

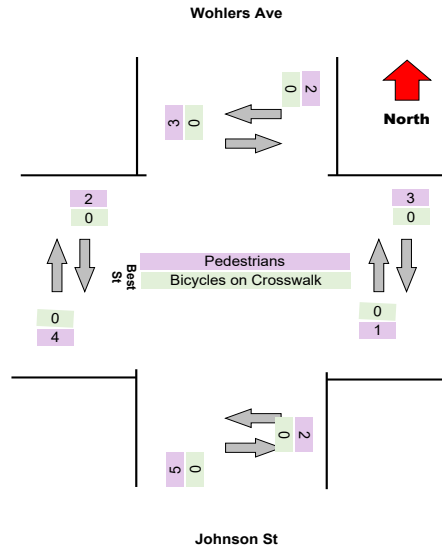
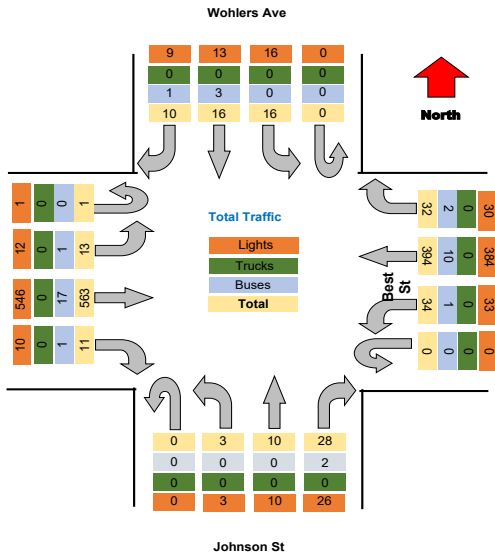



### Turning Movement Data Plot

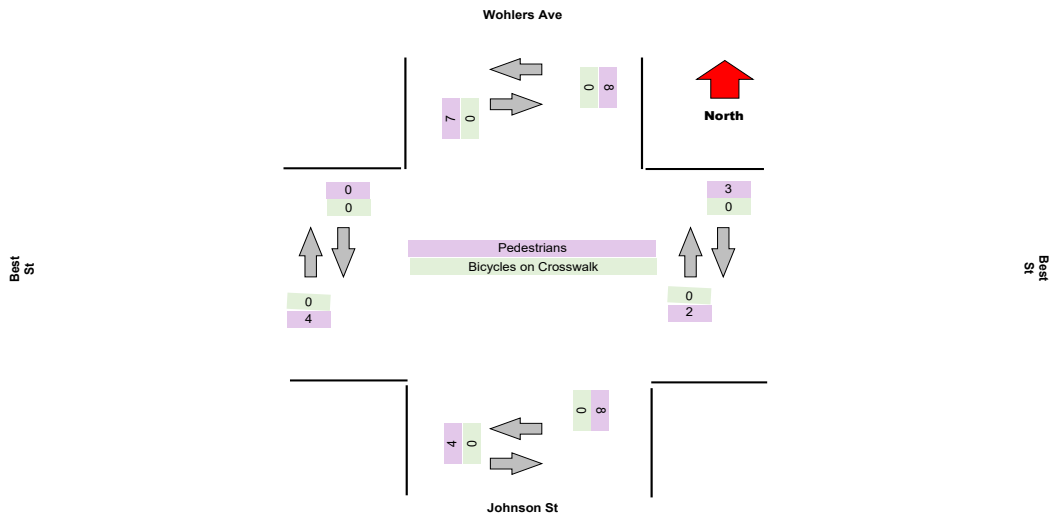
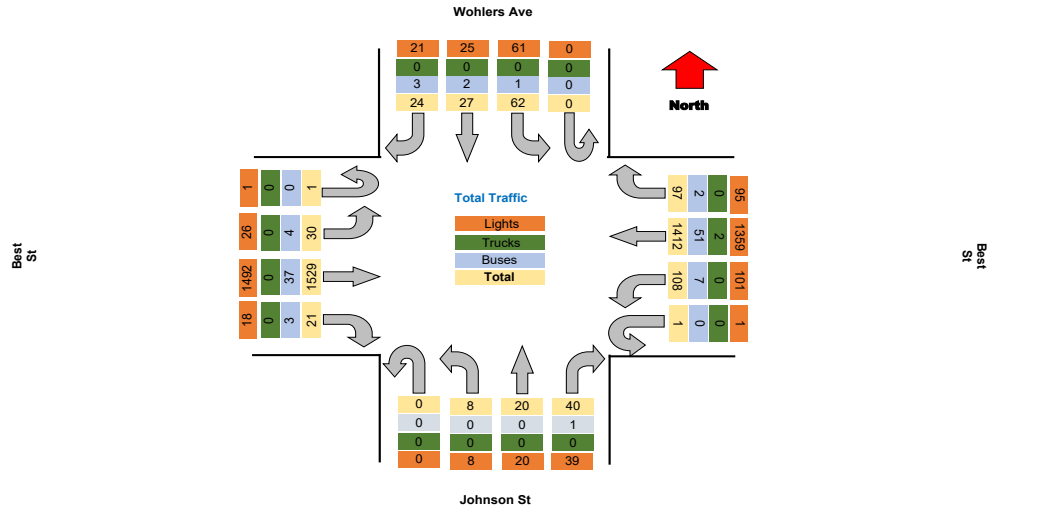

Project : VBH Malta NY  
Site : Site 4  
Location : 42.948550, -73.790036

TSTData.com

Survey Date : 2021-04-28, Wednesday

### Turning Movement Peak Hour Data (AM)

6:30:00 AM

Leg Direction	Wohlers Ave							Best St							Johnson St							Best St							Total	
	Southbound			Westbound				Northbound			Eastbound				Northbound			Eastbound												
Start Time	Right	Thru	Left	U-Turn	App Total	Peds CW	Peds CCW	Right	Thru	Left	U-Turn	App Total	Peds CW	Peds CCW	Right	Thru	Left	U-Turn	App Total	Peds CW	Peds CCW	Right	Thru	Left	U-Turn	App Total	Peds CW	Peds CCW		
6:30:00 AM	2	0	5	0	7	0	0	1	96	3	0	100	0	0	2	0	0	0	2	0	0	0	40	0	0	40	0	0	149	
6:45:00 AM	1	0	1	0	2	0	0	1	100	5	0	106	0	0	1	1	1	0	3	0	0	0	44	0	0	45	0	0	156	
7:00:00 AM	1	1	2	0	4	0	1	2	89	2	0	92	0	0	0	0	1	0	1	4	0	0	44	2	0	45	0	0	124	
7:15:00 AM	2	0	3	0	5	1	0	4	91	2	0	93	0	0	0	0	1	0	1	1	1	0	2	66	1	0	69	0	0	172
<b>Grand Total</b>	<b>6</b>	<b>1</b>	<b>11</b>	<b>0</b>	<b>18</b>	<b>1</b>	<b>1</b>	<b>8</b>	<b>356</b>	<b>12</b>	<b>0</b>	<b>377</b>	<b>0</b>	<b>0</b>	<b>3</b>	<b>1</b>	<b>3</b>	<b>0</b>	<b>7</b>	<b>5</b>	<b>1</b>	<b>3</b>	<b>153</b>	<b>3</b>	<b>0</b>	<b>159</b>	<b>3</b>	<b>0</b>	<b>691</b>	
% Approach	33.3%	5.6%	61.1%	0.0%	0.0%	0.0%	0.0%	2.1%	94.4%	3.2%	0.0%	0.0%	0.0%	0.0%	42.9%	14.3%	42.9%	0.0%	0.0%	0.0%	0.0%	1.5%	97.0%	1.5%	0.0%	0.0%	0.0%	0.0%	0.0%	
% Total	1.0%	0.2%	1.8%	0.0%	3.0%	0.0%	0.0%	1.3%	59.2%	2.0%	0.0%	62.7%	0.0%	0.0%	0.5%	0.2%	0.5%	0.0%	1.2%	0.0%	0.0%	0.5%	32.1%	0.5%	0.0%	33.1%	0.0%	0.0%	0.0%	
PHF	0.750	0.250	0.550	0.000	0.643	0.000	0.000	0.500	0.890	0.600	0.000	0.889	0.000	0.000	0.375	0.250	0.750	0.000	0.583	0.000	0.000	0.375	0.731	0.375	0.000	0.721	0.000	0.000	0.874	
Lights	4	1	11	0	16	0	0	8	338	10	0	356	0	0	3	1	3	0	7	0	0	1	182	1	0	184	0	0	563	
% Lights	66.7%	100.0%	100.0%	0.0%	88.9%	0.0%	0.0%	100.0%	94.9%	83.3%	0.0%	94.4%	0.0%	0.0%	100.0%	100.0%	100.0%	0.0%	100.0%	0.0%	0.0%	33.3%	94.3%	33.3%	0.0%	92.5%	0.0%	0.0%	93.7%	
Trucks	0	0	0	0	0	0	0	0	1	0	0	1	0	0	0	0	0	0	0	0	0	0	0	0	0	0	0	0	1	
% Trucks	0.0%	0.0%	0.0%	0.0%	0.0%	0.0%	0.0%	0.0%	0.3%	0.0%	0.0%	0.3%	0.0%	0.0%	0.0%	0.0%	0.0%	0.0%	0.0%	0.0%	0.0%	0.0%	0.0%	0.0%	0.0%	0.0%	0.0%	0.0%	0.2%	
Buses	2	0	0	0	2	0	0	0	17	2	0	19	0	0	0	0	0	0	0	0	0	2	11	2	0	15	0	0	36	
% Buses	33.3%	0.0%	0.0%	0.0%	0.0%	0.0%	0.0%	0.0%	4.8%	16.7%	0.0%	0.0%	0.0%	0.0%	0.0%	0.0%	0.0%	0.0%	0.0%	0.0%	0.0%	66.7%	5.7%	66.7%	0.0%	0.0%	0.0%	6.0%		
Pedestrians	0	0	0	0	0	1	1	0	0	0	0	0	0	0	0	0	0	0	0	5	1	0	0	0	0	0	0	0	0	
% Pedestrians	0.0%	0.0%	0.0%	0.0%	0.0%	100.0%	100.0%	0.0%	0.0%	0.0%	0.0%	0.0%	0.0%	0.0%	0.0%	0.0%	0.0%	0.0%	0.0%	0.0%	100.0%	100.0%	0.0%	0.0%	0.0%	0.0%	0.0%	0.0%	0.0%	
Bicycles on Crosswalk	0	0	0	0	0	0	0	0	0	0	0	0	0	0	0	0	0	0	0	0	0	0	0	0	0	0	0	0	0	
% Bicycles on Crosswalk	0.0%	0.0%	0.0%	0.0%	0.0%	0.0%	0.0%	0.0%	0.0%	0.0%	0.0%	0.0%	0.0%	0.0%	0.0%	0.0%	0.0%	0.0%	0.0%	0.0%	0.0%	0.0%	0.0%	0.0%	0.0%	0.0%	0.0%	0.0%	0.0%	

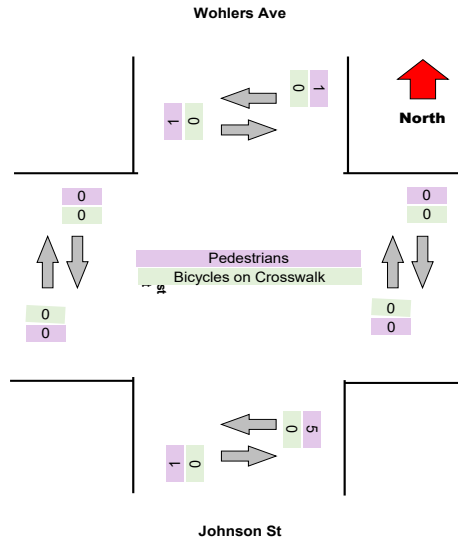
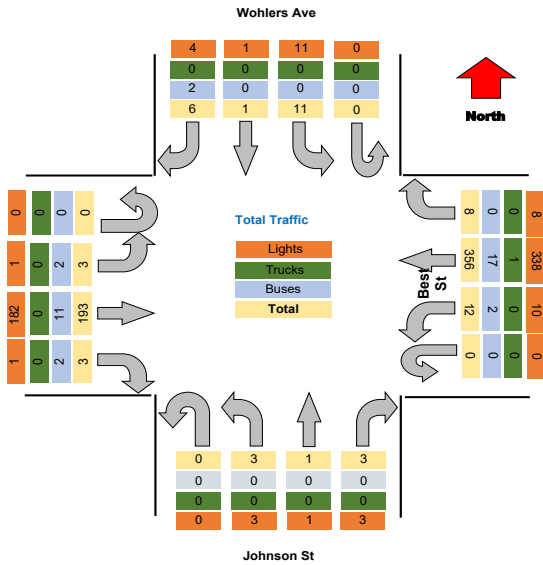

**Turning Movement Peak Hour Data (PM)**

4:15:00 PM

Leg Direction	Wohlers Ave						Best St						Johnson St						Best St						Total				
	Southbound			Westbound			Northbound			Eastbound			Northbound			Eastbound													
	Right	Thru	Left	U-Turn	App Total	Peds CW	Peds CCW	Right	Thru	Left	U-Turn	App Total	Peds CW	Peds CCW	Right	Thru	Left	U-Turn	App Total	Peds CW	Peds CCW								
4:15:00 PM	3	3	6	0	12	2	1	14	93	15	0	122	3	1	3	0	2	0	5	1	1	3	132	2	0	137	0	0	276
4:30:00 PM	3	4	12	0	19	0	0	10	68	10	0	88	0	0	12	3	2	0	17	0	0	1	153	3	0	157	0	0	281
4:45:00 PM	1	4	5	0	10	0	2	11	87	13	0	111	0	0	2	4	0	0	6	0	0	2	126	5	0	133	0	0	260
5:00:00 PM	1	3	0	0	4	0	0	6	62	6	0	74	0	0	1	3	0	0	4	1	0	5	132	5	0	142	0	0	244
<b>Grand Total</b>	<b>9</b>	<b>14</b>	<b>23</b>	<b>0</b>	<b>45</b>	<b>2</b>	<b>3</b>	<b>41</b>	<b>330</b>	<b>44</b>	<b>0</b>	<b>415</b>	<b>3</b>	<b>1</b>	<b>19</b>	<b>10</b>	<b>4</b>	<b>0</b>	<b>32</b>	<b>2</b>	<b>1</b>	<b>11</b>	<b>543</b>	<b>15</b>	<b>0</b>	<b>558</b>	<b>3</b>	<b>0</b>	<b>1061</b>
% Approach	17.8%	31.1%	51.1%	0.0%	0.0%	0.0%	0.0%	9.0%	79.5%	10.6%	0.0%	0.0%	0.0%	0.0%	56.3%	31.3%	12.5%	0.0%	0.0%	0.0%	0.0%	1.9%	95.4%	2.6%	0.0%	0.0%	0.0%	0.0%	0.0%
% Total	0.8%	1.3%	2.2%	0.0%	4.2%	0.0%	0.0%	3.9%	31.1%	4.1%	0.0%	38.1%	0.0%	0.0%	1.7%	0.9%	0.4%	0.0%	3.0%	0.0%	0.0%	1.0%	51.2%	1.4%	0.0%	53.6%	0.0%	0.0%	0.0%
PHF	0.667	0.875	0.479	0.000	0.592	0.000	0.000	0.732	0.887	0.733	0.000	0.850	0.000	0.000	0.375	0.625	0.500	0.000	0.471	0.000	0.000	0.550	0.887	0.750	0.000	0.906	0.000	0.000	0.944
Lights	7	12	23	0	42	0	0	40	318	42	0	400	0	0	17	10	4	0	31	0	0	10	533	14	0	557	0	0	1030
% Lights	87.5%	85.7%	100.0%	0.0%	93.3%	0.0%	0.0%	87.6%	96.4%	95.5%	0.0%	96.4%	0.0%	0.0%	84.4%	100.0%	100.0%	0.0%	96.9%	0.0%	0.0%	90.9%	98.2%	93.3%	0.0%	97.9%	0.0%	0.0%	97.1%
Trucks	0	0	0	0	0	0	0	0	0	0	0	0	0	0	0	0	0	0	0	0	0	0	0	0	0	0	0	0	0
% Trucks	0.0%	0.0%	0.0%	0.0%	0.0%	0.0%	0.0%	0.0%	0.0%	0.0%	0.0%	0.0%	0.0%	0.0%	0.0%	0.0%	0.0%	0.0%	0.0%	0.0%	0.0%	0.0%	0.0%	0.0%	0.0%	0.0%	0.0%	0.0%	0.0%
Buses	1	2	0	0	3	0	0	1	12	2	0	15	0	0	1	0	0	0	1	0	0	1	10	1	0	12	0	0	31
% Buses	12.5%	14.3%	0.0%	0.0%	0.0%	0.0%	0.0%	2.4%	3.6%	4.5%	0.0%	0.0%	0.0%	0.0%	5.6%	0.0%	0.0%	0.0%	0.0%	0.0%	0.0%	9.1%	1.8%	6.7%	0.0%	0.0%	0.0%	2.9%	
Pedestrians	0	0	0	0	0	2	4	0	0	0	0	3	1	0	0	0	0	0	0	2	1	0	0	0	0	0	0	0	
% Pedestrians	0.0%	0.0%	0.0%	0.0%	0.0%	100.0%	100.0%	0.0%	0.0%	0.0%	0.0%	0.0%	100.0%	100.0%	0.0%	0.0%	0.0%	0.0%	0.0%	0.0%	100.0%	100.0%	0.0%	0.0%	0.0%	0.0%	0.0%	0.0%	0.0%
Bicycles on Crosswalk	0	0	0	0	0	0	0	0	0	0	0	0	0	0	0	0	0	0	0	0	0	0	0	0	0	0	0	0	0
% Bicycles on Crosswalk	0.0%	0.0%	0.0%	0.0%	0.0%	0.0%	0.0%	0.0%	0.0%	0.0%	0.0%	0.0%	0.0%	0.0%	0.0%	0.0%	0.0%	0.0%	0.0%	0.0%	0.0%	0.0%	0.0%	0.0%	0.0%	0.0%	0.0%	0.0%	0.0%

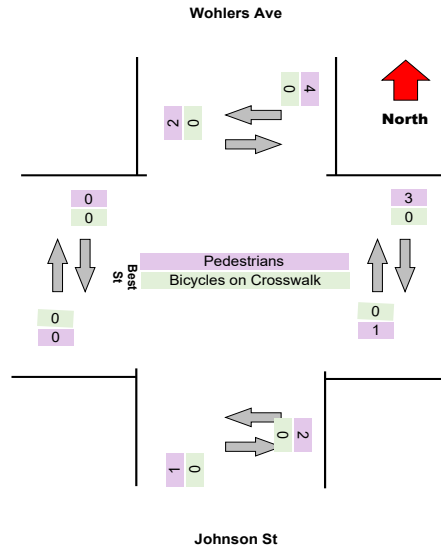
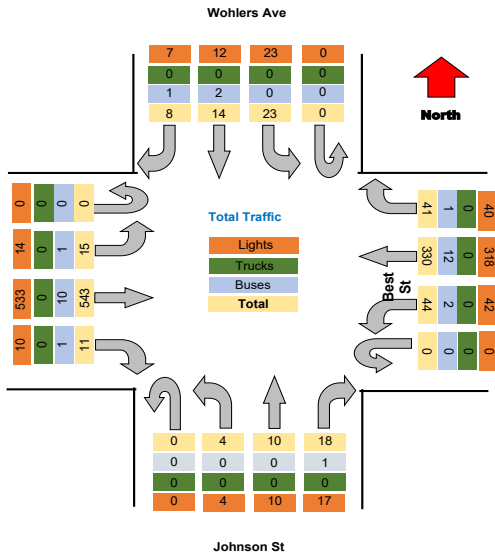





Turning Movement Data Plot

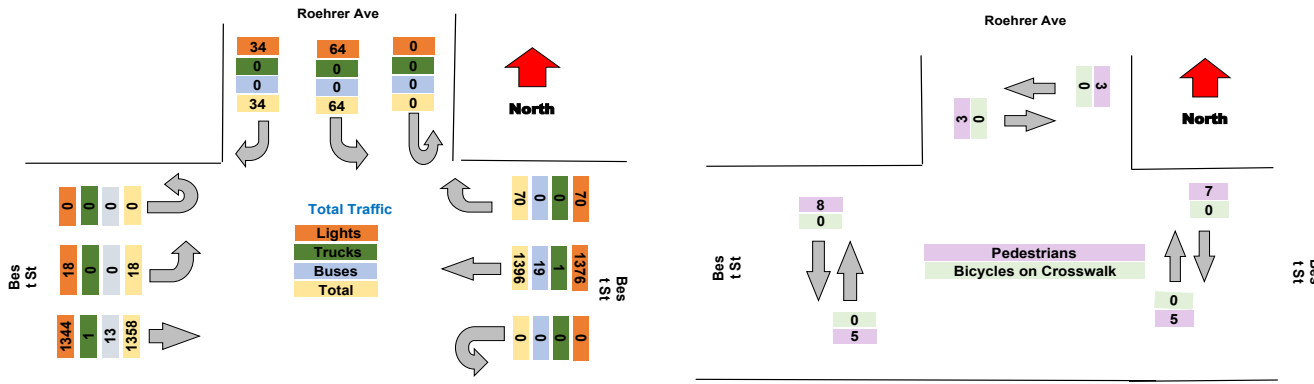

Turning Movement Peak Hour Data (AM)

7:30:00 AM

Leg Direction	Roehrer Ave Southbound						Best St Westbound						Best St Eastbound						Total
	Right	Left	U-Turn	App Total	Peds CW	Peds CCW	Right	Thru	U-Turn	App Total	Peds CW	Peds CCW	Thru	Left	U-Turn	App Total	Peds CW	Peds CCW	
7:30:00 AM	2	3	0	5	0	0	2	88	0	90	0	0	75	0	0	75	0	0	170
7:45:00 AM	1	7	0	8	0	0	9	98	0	107	1	0	59	1	0	61	0	1	176
8:00:00 AM	1	4	0	5	0	1	4	83	0	88	0	0	56	0	0	56	0	3	149
8:15:00 AM	0	3	0	3	0	0	1	102	0	103	0	0	52	0	0	52	0	0	158
<b>Grand Total</b>	4	17	0	21	0	1	16	371	0	388	1	0	242	1	0	244	0	4	653
% Approach	19.0%	81.0%	0.0%	0.0%	0.0%	0.0%	4.1%	95.6%	0.0%	0.0%	0.0%	0.0%	99.2%	0.4%	0.0%	0.0%	0.0%	0.0%	
% Total	0.6%	2.6%	0.0%	3.2%	0.0%	0.0%	2.5%	56.8%	0.0%	59.4%	0.0%	0.0%	37.1%	0.2%	0.0%	37.4%	0.0%	0.0%	
PHF	0.500	0.607	0.000	0.656	0.000	0.000	0.444	0.909	0.000	0.907	0.000	0.000	0.807	0.250	0.000	0.813	0.000	0.000	0.928
Lights	4	17	0	21	0	1	16	362	0	378	0	0	236	1	0	237	0	0	636
% Lights	#####	100.0%	0.0%	100.0%	0.0%	0.0%	100.0%	97.6%	0.0%	97.4%	0.0%	0.0%	97.5%	100.0%	0.0%	97.1%	0.0%	0.0%	97.4%
Trucks	0	0	0	0	0	0	0	0	0	0	0	0	1	0	0	1	0	0	1
% Trucks	0.0%	0.0%	0.0%	0.0%	0.0%	0.0%	0.0%	0.0%	0.0%	0.0%	0.0%	0.0%	0.4%	0.0%	0.0%	0.4%	0.0%	0.0%	0.2%
Buses	0	0	0	0	0	0	0	9	0	9	0	0	5	0	0	5	0	0	14
% Buses	0.0%	0.0%	0.0%	0.0%	0.0%	0.0%	0.0%	2.4%	0.0%	0.0%	0.0%	0.0%	2.1%	0.0%	0.0%	0.0%	0.0%	0.0%	2.1%
Pedestrians	0	0	0	0	0	1	0	0	0	1	0	0	0	0	0	0	0	4	0
% Pedestrians	0.0%	0.0%	0.0%	0.0%	0.0%	100.0%	0.0%	0.0%	0.0%	0.0%	100.0%	0.0%	0.0%	0.0%	0.0%	0.0%	0.0%	100.0%	0.0%
Bicycles on Crosswalk	0	0	0	0	0	0	0	0	0	0	0	0	0	0	0	0	0	0	0
% Bicycles on Crosswalk	0.0%	0.0%	0.0%	0.0%	0.0%	0.0%	0.0%	0.0%	0.0%	0.0%	0.0%	0.0%	0.0%	0.0%	0.0%	0.0%	0.0%	0.0%	0.0%

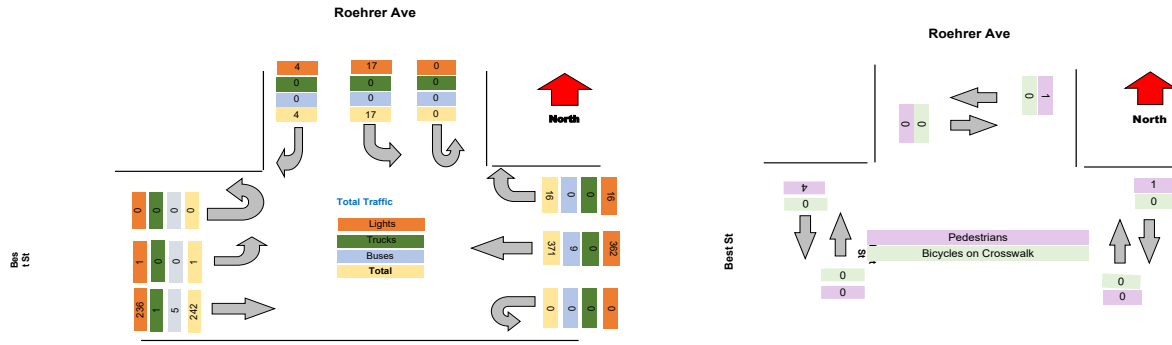

Turning Movement Peak Hour Data (PM)  
 4:15:00 PM

Leg Direction	Roehrer Ave Southbound						Best St Westbound						Best St Eastbound						Total
	Right	Left	U-Turn	App Total	Peds CW	Peds CCW	Right	Thru	U-Turn	App Total	Peds CW	Peds CCW	Thru	Left	U-Turn	App Total	Peds CW	Peds CCW	
4:15:00 PM	3	5	0	8	0	0	5	87	0	92	1	1	128	0	0	128	0	0	228
4:30:00 PM	3	2	0	5	1	0	11	87	0	98	0	0	125	1	0	126	0	0	229
4:45:00 PM	6	5	0	11	0	0	6	88	0	94	1	1	108	3	0	111	1	0	216
5:00:00 PM	5	3	0	8	0	1	4	99	0	103	0	0	137	5	0	142	0	0	253
<b>Grand Total</b>	17	15	0	32	1	1	26	361	0	387	2	2	498	9	0	507	1	0	926
% Approach	53.1%	46.9%	0.0%	0.0%	0.0%	0.0%	6.7%	93.3%	0.0%	0.0%	0.0%	0.0%	98.2%	1.8%	0.0%	0.0%	0.0%	0.0%	
% Total	1.8%	1.6%	0.0%	3.5%	0.0%	0.0%	2.8%	39.0%	0.0%	41.8%	0.0%	0.0%	53.8%	1.0%	0.0%	54.8%	0.0%	0.0%	
PHF	0.708	0.750	0.000	0.727	0.000	0.000	0.591	0.912	0.000	0.939	0.000	0.000	0.909	0.450	0.000	0.893	0.000	0.000	0.915
Lights	17	15	0	32	0	0	26	358	0	384	0	0	495	9	0	504	0	0	920
% Lights	###	100.0%	0.0%	100.0%	0.0%	0.0%	100.0%	99.2%	0.0%	99.2%	0.0%	0.0%	99.4%	100.0%	0.0%	99.4%	0.0%	0.0%	99.4%
Trucks	0	0	0	0	0	0	0	0	0	0	0	0	0	0	0	0	0	0	0
% Trucks	0.0%	0.0%	0.0%	0.0%	0.0%	0.0%	0.0%	0.0%	0.0%	0.0%	0.0%	0.0%	0.0%	0.0%	0.0%	0.0%	0.0%	0.0%	0.0%
Buses	0	0	0	0	0	0	0	3	0	3	0	0	3	0	0	3	0	0	6
% Buses	0.0%	0.0%	0.0%	0.0%	0.0%	0.0%	0.0%	0.8%	0.0%	0.0%	0.0%	0.0%	0.6%	0.0%	0.0%	0.0%	0.0%	0.0%	0.6%
Pedestrians	0	0	0	0	1	1	0	0	0	0	2	2	0	0	0	0	1	0	0
% Pedestrians	0.0%	0.0%	0.0%	0.0%	100.0%	100.0%	0.0%	0.0%	0.0%	0.0%	100.0%	100.0%	0.0%	0.0%	0.0%	0.0%	100.0%	0.0%	0.0%
Bicycles on Crosswalk	0	0	0	0	0	0	0	0	0	0	0	0	0	0	0	0	0	0	0
% Bicycles on Crosswalk	0.0%	0.0%	0.0%	0.0%	0.0%	0.0%	0.0%	0.0%	0.0%	0.0%	0.0%	0.0%	0.0%	0.0%	0.0%	0.0%	0.0%	0.0%	0.0%

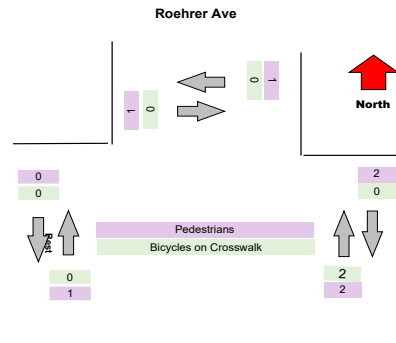
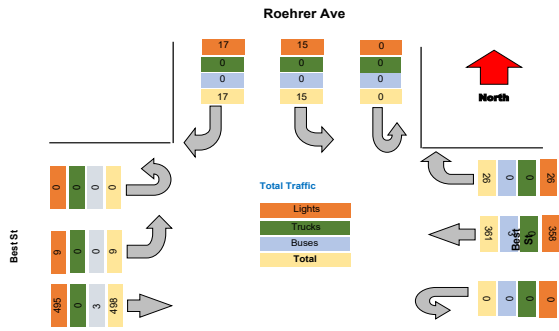

Intersection: Elm St Pine St  
 Location: Kennett Square, PA  
 Site: 01  
 Survey Date: Wednesday, 04-28-2021  
 GPS: 42.948550, -72.790034



Project	LaBella
Project Code	LaBella
Site Name	U
Legs and Movements	All Processed Legs & Movements
Bin Size	15 minutes
Survey Date	2021-11-03, Wednesday
Location	U
Latitude and Longitude	42.903791, -78.849141

	Start	End	PHF
Forced Peak AM	2021/11/03 07:30:00	2021/11/03 08:30:00	0.8357
Forced Peak PM	2021/11/03 16:30:00	2021/11/03 17:30:00	0.9099
AM Peak	2021/11/03 07:30:00	2021/11/03 08:30:00	0.8357
PM Peak	2021/11/03 16:15:00	2021/11/03 17:15:00	0.9461

Turning Movement Data

Leg Direction	Roehrer Ave Southbound						Best St Westbound						Best St Eastbound						Total
	Right	Left	U-Turn	App Total	Peds CW	Peds CCW	Right	Thru	U-Turn	App Total	Peds CW	Peds CCW	Thru	Left	U-Turn	App Total	Peds CW	Peds CCW	
Start Time																			
6:30:00 AM	0	1	0	1	0	0	1	95	0	96	0	0	25	0	0	25	0	0	122
6:45:00 AM	2	2	1	5	1	2	3	106	0	111	0	1	39	0	0	40	2	3	156
<b>Hourly Total</b>	<b>2</b>	<b>3</b>	<b>1</b>	<b>6</b>	<b>1</b>	<b>2</b>	<b>4</b>	<b>201</b>	<b>0</b>	<b>207</b>	<b>0</b>	<b>1</b>	<b>64</b>	<b>0</b>	<b>0</b>	<b>65</b>	<b>2</b>	<b>3</b>	<b>278</b>
7:00:00 AM	0	2	0	2	0	1	4	69	0	74	0	0	65	2	0	67	0	0	143
7:15:00 AM	2	4	0	6	1	2	1	112	0	115	0	0	64	0	0	64	0	0	185
7:30:00 AM	3	3	0	6	0	2	2	96	0	100	0	0	105	0	0	105	0	0	211
7:45:00 AM	0	5	0	5	2	1	7	151	1	160	0	0	116	2	0	118	0	1	283
<b>Hourly Total</b>	<b>5</b>	<b>14</b>	<b>0</b>	<b>19</b>	<b>3</b>	<b>6</b>	<b>14</b>	<b>428</b>	<b>1</b>	<b>449</b>	<b>0</b>	<b>0</b>	<b>350</b>	<b>4</b>	<b>0</b>	<b>354</b>	<b>0</b>	<b>1</b>	<b>822</b>
8:00:00 AM	1	2	0	3	0	1	3	138	0	142	0	0	116	2	0	118	0	3	263
8:15:00 AM	2	3	0	5	1	0	5	107	0	112	0	0	72	0	0	72	0	0	189
<b>Hourly Total</b>	<b>3</b>	<b>5</b>	<b>0</b>	<b>8</b>	<b>1</b>	<b>1</b>	<b>8</b>	<b>245</b>	<b>0</b>	<b>254</b>	<b>0</b>	<b>0</b>	<b>188</b>	<b>2</b>	<b>0</b>	<b>190</b>	<b>0</b>	<b>3</b>	<b>452</b>
4:00:00 PM	4	3	0	7	4	1	7	93	0	100	0	0	164	2	0	166	2	0	273
4:15:00 PM	4	8	0	12	1	1	3	110	0	113	0	0	139	4	0	143	0	0	268
4:30:00 PM	3	4	0	7	1	1	5	87	0	92	1	1	166	4	0	170	0	0	269
4:45:00 PM	4	4	0	8	0	0	3	97	0	100	0	1	123	3	0	126	0	0	234
<b>Hourly Total</b>	<b>15</b>	<b>19</b>	<b>0</b>	<b>34</b>	<b>6</b>	<b>3</b>	<b>18</b>	<b>387</b>	<b>0</b>	<b>405</b>	<b>1</b>	<b>2</b>	<b>592</b>	<b>13</b>	<b>0</b>	<b>605</b>	<b>2</b>	<b>0</b>	<b>1044</b>
5:00:00 PM	1	5	0	6	1	0	2	101	0	103	0	1	138	0	0	138	0	0	247
5:15:00 PM	3	4	0	7	0	0	2	88	0	90	0	0	131	1	0	132	0	0	229
5:30:00 PM	1	4	0	5	1	0	4	94	0	98	0	1	119	1	0	120	1	2	223
5:45:00 PM	4	2	0	6	0	1	6	81	0	87	0	0	93	0	0	93	0	0	186
<b>Hourly Total</b>	<b>9</b>	<b>15</b>	<b>0</b>	<b>24</b>	<b>2</b>	<b>1</b>	<b>14</b>	<b>364</b>	<b>0</b>	<b>378</b>	<b>0</b>	<b>2</b>	<b>481</b>	<b>2</b>	<b>0</b>	<b>483</b>	<b>1</b>	<b>2</b>	<b>885</b>
<b>Grand Total</b>	<b>34</b>	<b>56</b>	<b>1</b>	<b>91</b>	<b>13</b>	<b>13</b>	<b>58</b>	<b>1625</b>	<b>1</b>	<b>1693</b>	<b>1</b>	<b>5</b>	<b>1675</b>	<b>21</b>	<b>0</b>	<b>1697</b>	<b>5</b>	<b>9</b>	<b>3481</b>
<b>% Approach</b>	<b>37.4%</b>	<b>61.5%</b>	<b>1.1%</b>	<b>0.0%</b>	<b>0.0%</b>	<b>0.0%</b>	<b>3.4%</b>	<b>96.0%</b>	<b>0.1%</b>	<b>0.0%</b>	<b>0.0%</b>	<b>0.0%</b>	<b>98.7%</b>	<b>1.2%</b>	<b>0.0%</b>	<b>0.0%</b>	<b>0.0%</b>	<b>0.0%</b>	<b>0.0%</b>
<b>% Total</b>	<b>1.0%</b>	<b>1.6%</b>	<b>0.0%</b>	<b>2.6%</b>	<b>0.0%</b>	<b>0.0%</b>	<b>1.7%</b>	<b>46.7%</b>	<b>0.0%</b>	<b>48.6%</b>	<b>0.0%</b>	<b>0.0%</b>	<b>48.1%</b>	<b>0.6%</b>	<b>0.0%</b>	<b>48.8%</b>	<b>0.0%</b>	<b>0.0%</b>	<b>0.0%</b>
<b>Lights</b>	<b>31</b>	<b>53</b>	<b>1</b>	<b>85</b>	<b>0</b>	<b>0</b>	<b>58</b>	<b>1568</b>	<b>1</b>	<b>1627</b>	<b>0</b>	<b>0</b>	<b>1612</b>	<b>21</b>	<b>0</b>	<b>1633</b>	<b>0</b>	<b>0</b>	<b>3345</b>
<b>% Lights</b>	<b>91.2%</b>	<b>94.6%</b>	<b>###</b>	<b>93.4%</b>	<b>0.0%</b>	<b>0.0%</b>	<b>100.0%</b>	<b>96.5%</b>	<b>100.0%</b>	<b>96.1%</b>	<b>0.0%</b>	<b>0.0%</b>	<b>96.2%</b>	<b>100.0%</b>	<b>0.0%</b>	<b>96.2%</b>	<b>0.0%</b>	<b>0.0%</b>	<b>96.1%</b>
<b>Trucks</b>	<b>0</b>	<b>0</b>	<b>0</b>	<b>0</b>	<b>0</b>	<b>0</b>	<b>0</b>	<b>2</b>	<b>0</b>	<b>2</b>	<b>0</b>	<b>0</b>	<b>2</b>	<b>0</b>	<b>0</b>	<b>2</b>	<b>0</b>	<b>0</b>	<b>4</b>
<b>% Trucks</b>	<b>0.0%</b>	<b>0.0%</b>	<b>0.0%</b>	<b>0.0%</b>	<b>0.0%</b>	<b>0.0%</b>	<b>0.0%</b>	<b>0.1%</b>	<b>0.0%</b>	<b>0.1%</b>	<b>0.0%</b>	<b>0.0%</b>	<b>0.1%</b>	<b>0.0%</b>	<b>0.0%</b>	<b>0.1%</b>	<b>0.0%</b>	<b>0.0%</b>	<b>0.1%</b>
<b>Buses</b>	<b>3</b>	<b>3</b>	<b>0</b>	<b>6</b>	<b>0</b>	<b>0</b>	<b>0</b>	<b>55</b>	<b>0</b>	<b>55</b>	<b>0</b>	<b>0</b>	<b>61</b>	<b>0</b>	<b>0</b>	<b>61</b>	<b>0</b>	<b>0</b>	<b>122</b>
<b>% Buses</b>	<b>8.8%</b>	<b>5.4%</b>	<b>0.0%</b>	<b>0.0%</b>	<b>0.0%</b>	<b>0.0%</b>	<b>0.0%</b>	<b>3.4%</b>	<b>0.0%</b>	<b>0.0%</b>	<b>0.0%</b>	<b>0.0%</b>	<b>3.6%</b>	<b>0.0%</b>	<b>0.0%</b>	<b>0.0%</b>	<b>0.0%</b>	<b>0.0%</b>	<b>3.5%</b>
<b>Pedestrians</b>	<b>0</b>	<b>0</b>	<b>0</b>	<b>0</b>	<b>13</b>	<b>11</b>	<b>0</b>	<b>0</b>	<b>0</b>	<b>0</b>	<b>1</b>	<b>5</b>	<b>0</b>	<b>0</b>	<b>0</b>	<b>0</b>	<b>5</b>	<b>9</b>	<b>0</b>
<b>% Pedestrians</b>	<b>0.0%</b>	<b>0.0%</b>	<b>0.0%</b>	<b>0.0%</b>	<b>100.0%</b>	<b>84.6%</b>	<b>0.0%</b>	<b>0.0%</b>	<b>0.0%</b>	<b>0.0%</b>	<b>100.0%</b>	<b>100.0%</b>	<b>0.0%</b>	<b>0.0%</b>	<b>0.0%</b>	<b>0.0%</b>	<b>100.0%</b>	<b>100.0%</b>	<b>0.0%</b>
<b>Bicycles on Crosswalk</b>	<b>0</b>	<b>0</b>	<b>0</b>	<b>0</b>	<b>0</b>	<b>2</b>	<b>0</b>	<b>0</b>	<b>0</b>	<b>0</b>	<b>0</b>	<b>0</b>	<b>0</b>	<b>0</b>	<b>0</b>	<b>0</b>	<b>0</b>	<b>0</b>	<b>0</b>
<b>% Bicycles on Crosswalk</b>	<b>0.0%</b>	<b>0.0%</b>	<b>0.0%</b>	<b>0.0%</b>	<b>0.0%</b>	<b>15.4%</b>	<b>0.0%</b>	<b>0.0%</b>	<b>0.0%</b>	<b>0.0%</b>	<b>0.0%</b>	<b>0.0%</b>	<b>0.0%</b>	<b>0.0%</b>	<b>0.0%</b>	<b>0.0%</b>	<b>0.0%</b>	<b>0.0%</b>	<b>0.0%</b>

Turning Movement Data Plot

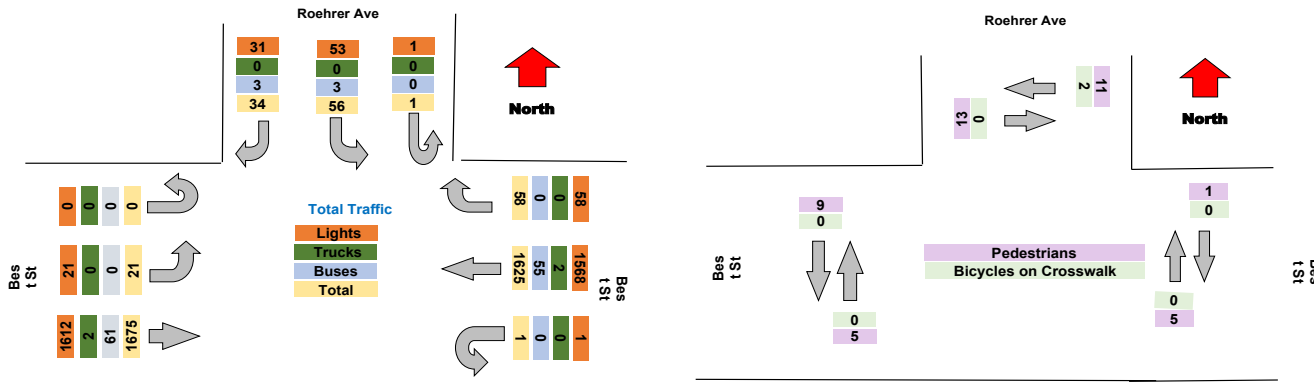

Turning Movement Peak Hour Data (AM)

7:30:00 AM

Leg Direction	Roehrer Ave Southbound						Best St Westbound						Best St Eastbound						Total
	Right	Left	U-Turn	App Total	Peds CW	Peds CCW	Right	Thru	U-Turn	App Total	Peds CW	Peds CCW	Thru	Left	U-Turn	App Total	Peds CW	Peds CCW	
7:30:00 AM	3	3	0	6	0	2	2	96	0	100	0	0	105	0	0	105	0	0	211
7:45:00 AM	0	5	0	5	2	1	7	151	1	160	0	0	116	2	0	118	0	1	283
8:00:00 AM	1	2	0	3	0	1	3	138	0	142	0	0	116	2	0	118	0	3	263
8:15:00 AM	2	3	0	5	1	0	5	107	0	112	0	0	72	0	0	72	0	0	189
<b>Grand Total</b>	6	13	0	19	3	4	17	492	1	514	0	0	409	4	0	413	0	4	946
% Approach	31.6%	68.4%	0.0%	0.0%	0.0%	0.0%	3.3%	95.7%	0.2%	0.0%	0.0%	0.0%	99.0%	1.0%	0.0%	0.0%	0.0%	0.0%	
% Total	0.6%	1.4%	0.0%	2.0%	0.0%	0.0%	1.8%	52.0%	0.1%	54.3%	0.0%	0.0%	43.2%	0.4%	0.0%	43.7%	0.0%	0.0%	
PHF	0.500	0.650	0.000	0.792	0.000	0.000	0.607	0.815	0.250	0.803	0.000	0.000	0.881	0.500	0.000	0.875	0.000	0.000	0.836
Lights	5	13	0	18	0	0	17	473	1	491	0	0	400	4	0	404	0	0	913
% Lights	83.3%	100.0%	0.0%	94.7%	0.0%	0.0%	100.0%	96.1%	100.0%	95.5%	0.0%	0.0%	97.8%	100.0%	0.0%	97.8%	0.0%	0.0%	96.5%
Trucks	0	0	0	0	0	0	0	1	0	1	0	0	0	0	0	0	0	0	1
% Trucks	0.0%	0.0%	0.0%	0.0%	0.0%	0.0%	0.0%	0.2%	0.0%	0.2%	0.0%	0.0%	0.0%	0.0%	0.0%	0.0%	0.0%	0.0%	0.1%
Buses	1	0	0	1	0	0	0	18	0	18	0	0	9	0	0	9	0	0	28
% Buses	16.7%	0.0%	0.0%	0.0%	0.0%	0.0%	0.0%	3.7%	0.0%	0.0%	0.0%	0.0%	2.2%	0.0%	0.0%	0.0%	0.0%	0.0%	3.0%
Pedestrians	0	0	0	0	3	4	0	0	0	0	0	0	0	0	0	0	0	4	0
% Pedestrians	0.0%	0.0%	0.0%	0.0%	100.0%	100.0%	0.0%	0.0%	0.0%	0.0%	0.0%	0.0%	0.0%	0.0%	0.0%	0.0%	0.0%	100.0%	0.0%
Bicycles on Crosswalk	0	0	0	0	0	0	0	0	0	0	0	0	0	0	0	0	0	0	0
% Bicycles on Crosswalk	0.0%	0.0%	0.0%	0.0%	0.0%	0.0%	0.0%	0.0%	0.0%	0.0%	0.0%	0.0%	0.0%	0.0%	0.0%	0.0%	0.0%	0.0%	0.0%

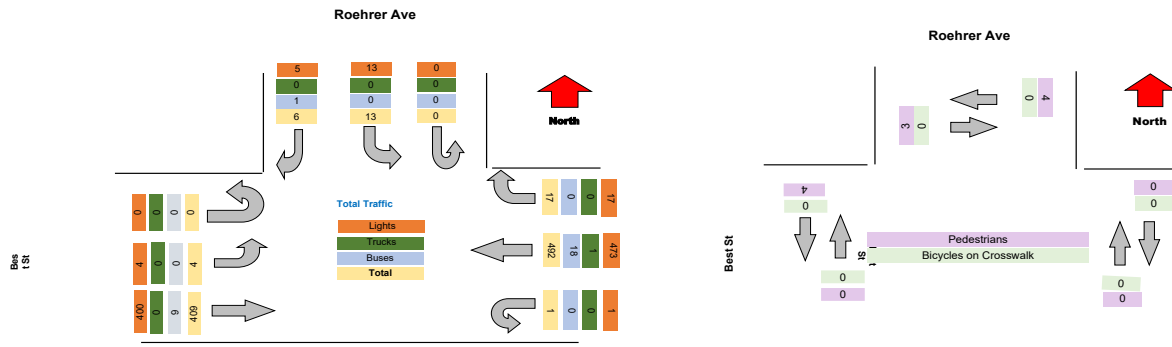

Turning Movement Peak Hour Data (PM)

4:15:00 PM

Leg Direction	Roehrer Ave Southbound						Best St Westbound						Best St Eastbound						Total
	Right	Left	U-Turn	App Total	Peds CW	Peds CCW	Right	Thru	U-Turn	App Total	Peds CW	Peds CCW	Thru	Left	U-Turn	App Total	Peds CW	Peds CCW	
4:15:00 PM	4	8	0	12	1	1	3	110	0	113	0	0	139	4	0	143	0	0	268
4:30:00 PM	3	4	0	7	1	1	5	87	0	92	1	1	166	4	0	170	0	0	269
4:45:00 PM	4	4	0	8	0	0	3	97	0	100	0	1	123	3	0	126	0	0	234
5:00:00 PM	1	5	0	6	1	0	2	101	0	103	0	1	138	0	0	138	0	0	247
<b>Grand Total</b>	12	21	0	33	3	2	13	395	0	408	1	3	566	11	0	577	0	0	1018
% Approach	36.4%	63.6%	0.0%	0.0%	0.0%	0.0%	3.2%	96.8%	0.0%	0.0%	0.0%	0.0%	98.1%	1.9%	0.0%	0.0%	0.0%	0.0%	
% Total	1.2%	2.1%	0.0%	3.2%	0.0%	0.0%	1.3%	38.8%	0.0%	40.1%	0.0%	0.0%	55.6%	1.1%	0.0%	56.7%	0.0%	0.0%	
PHF	0.750	0.656	0.000	0.688	0.000	0.000	0.650	0.898	0.000	0.903	0.000	0.000	0.852	0.688	0.000	0.849	0.000	0.000	0.946
Lights	11	20	0	31	0	0	13	384	0	397	0	0	548	11	0	559	0	0	987
% Lights	91.7%	95.2%	0.0%	93.9%	0.0%	0.0%	100.0%	97.2%	0.0%	97.3%	0.0%	0.0%	96.8%	100.0%	0.0%	96.9%	0.0%	0.0%	97.0%
Trucks	0	0	0	0	0	0	0	0	0	0	0	0	0	0	0	0	0	0	0
% Trucks	0.0%	0.0%	0.0%	0.0%	0.0%	0.0%	0.0%	0.0%	0.0%	0.0%	0.0%	0.0%	0.0%	0.0%	0.0%	0.0%	0.0%	0.0%	0.0%
Buses	1	1	0	2	0	0	0	11	0	11	0	0	18	0	0	18	0	0	31
% Buses	8.3%	4.8%	0.0%	0.0%	0.0%	0.0%	0.0%	2.8%	0.0%	0.0%	0.0%	0.0%	3.2%	0.0%	0.0%	0.0%	0.0%	0.0%	3.0%
Pedestrians	0	0	0	0	3	2	0	0	0	0	1	3	0	0	0	0	0	0	0
% Pedestrians	0.0%	0.0%	0.0%	0.0%	100.0%	100.0%	0.0%	0.0%	0.0%	0.0%	100.0%	100.0%	0.0%	0.0%	0.0%	0.0%	0.0%	0.0%	0.0%
Bicycles on Crosswalk	0	0	0	0	0	0	0	0	0	0	0	0	0	0	0	0	0	0	0
% Bicycles on Crosswalk	0.0%	0.0%	0.0%	0.0%	0.0%	0.0%	0.0%	0.0%	0.0%	0.0%	0.0%	0.0%	0.0%	0.0%	0.0%	0.0%	0.0%	0.0%	0.0%

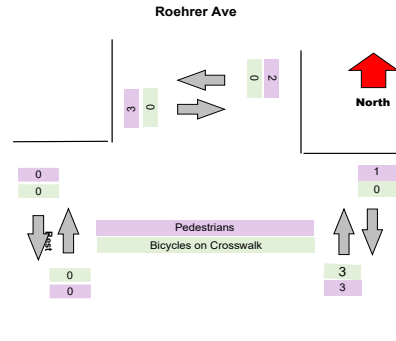
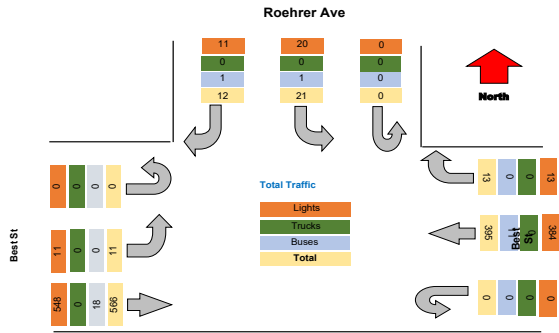



Intersection: Elm St Pine St  
 Location: Kennett Square, PA  
 Site: 01  
 Survey Date: Wednesday, 04-28-2021  
 GPS: 42.948550, -72.790034



Project	LaBella
Project Code	LaBella
Site Name	U
Legs and Movements	All Processed Legs & Movements
Bin Size	15 minutes
Survey Date	2021-11-04, Thursday
Location	U
Latitude and Longitude	42.903791, -78.849141

	Start	End	PHF
Forced Peak AM	2021/11/04 07:30:00	2021/11/04 08:30:00	0.8635
Forced Peak PM	2021/11/04 16:30:00	2021/11/04 17:30:00	0.9809
AM Peak	2021/11/04 07:30:00	2021/11/04 08:30:00	0.8635
PM Peak	2021/11/04 16:15:00	2021/11/04 17:15:00	0.9658

Turning Movement Data

Leg Direction	Roehrer Ave Southbound						Best St Westbound						Best St Eastbound						Total
	Right	Left	U-Turn	App Total	Peds CW	Peds CCW	Right	Thru	U-Turn	App Total	Peds CW	Peds CCW	Thru	Left	U-Turn	App Total	Peds CW	Peds CCW	
Start Time																			
6:30:00 AM	0	0	0	0	0	0	2	101	0	103	0	0	40	0	0	40	0	0	
6:45:00 AM	0	1	0	1	1	0	1	99	0	100	0	0	43	0	0	43	1	3	
<b>Hourly Total</b>	0	1	0	1	1	0	3	200	0	203	0	0	83	0	0	83	1	3	
7:00:00 AM	0	3	0	3	2	1	3	68	0	72	0	0	47	0	0	47	2	0	
7:15:00 AM	2	3	0	5	1	0	7	88	0	95	0	0	63	0	0	63	0	1	
7:30:00 AM	1	2	0	3	0	0	4	110	0	114	0	0	97	0	0	97	0	0	
7:45:00 AM	0	5	0	5	0	1	2	142	0	145	0	0	130	2	0	132	0	0	
<b>Hourly Total</b>	3	13	0	16	3	2	16	408	0	426	0	0	337	2	0	339	2	1	
8:00:00 AM	0	4	0	4	0	0	7	134	0	141	1	0	117	1	0	119	0	3	
8:15:00 AM	2	1	0	3	0	1	6	121	0	128	0	0	83	0	0	83	0	0	
<b>Hourly Total</b>	2	5	0	7	0	1	13	255	0	269	1	0	200	1	0	202	0	3	
4:00:00 PM	5	5	0	10	0	0	4	92	0	96	0	1	176	4	0	180	0	0	
4:15:00 PM	2	5	0	7	2	0	6	93	0	99	0	0	133	2	0	135	0	0	
4:30:00 PM	2	6	0	8	0	0	4	67	0	71	0	0	146	4	0	150	0	1	
4:45:00 PM	4	3	0	7	0	4	5	84	0	89	0	0	131	4	0	135	0	0	
<b>Hourly Total</b>	13	19	0	32	2	4	19	336	0	355	0	1	586	14	0	600	0	1	
5:00:00 PM	3	4	0	7	0	1	7	79	0	86	0	1	137	0	0	137	0	0	
5:15:00 PM	4	5	0	9	1	0	5	99	0	104	0	0	120	3	0	123	0	0	
5:30:00 PM	5	6	0	11	0	0	2	94	0	96	0	0	109	1	0	110	1	1	
5:45:00 PM	2	4	0	6	0	1	8	84	0	92	2	2	107	1	0	108	0	1	
<b>Hourly Total</b>	14	19	0	33	1	2	22	356	0	378	2	3	473	5	0	478	1	2	
<b>Grand Total</b>	32	57	0	89	7	9	73	1555	0	1631	3	4	1679	22	0	1702	4	10	
% Approach	36.0%	64.0%	0.0%	0.0%	0.0%	0.0%	4.5%	95.3%	0.0%	0.0%	0.0%	0.0%	98.6%	1.3%	0.0%	0.0%	0.0%	0.0%	
% Total	0.9%	1.7%	0.0%	2.6%	0.0%	0.0%	2.1%	45.4%	0.0%	47.7%	0.0%	0.0%	49.1%	0.6%	0.0%	49.7%	0.0%	0.0%	
Lights	32	55	0	87	0	0	71	1498	0	1569	0	0	1629	22	0	1651	0	0	
% Lights	#####	96.5%	0.0%	97.8%	0.0%	0.0%	97.3%	96.3%	0.0%	96.2%	0.0%	0.0%	97.0%	100.0%	0.0%	97.0%	0.0%	0.0%	
Trucks	0	0	0	0	0	0	0	1	0	1	0	0	0	0	0	0	0	0	
% Trucks	0.0%	0.0%	0.0%	0.0%	0.0%	0.0%	0.0%	0.1%	0.0%	0.1%	0.0%	0.0%	0.0%	0.0%	0.0%	0.0%	0.0%	0.0%	
Buses	0	2	0	2	0	0	2	56	0	58	0	0	50	0	0	50	0	0	
% Buses	0.0%	3.5%	0.0%	0.0%	0.0%	0.0%	0.0%	3.6%	0.0%	0.0%	0.0%	0.0%	3.0%	0.0%	0.0%	0.0%	0.0%	0.0%	
Pedestrians	0	0	0	0	7	9	0	0	0	0	3	4	0	0	0	0	4	10	
% Pedestrians	0.0%	0.0%	0.0%	0.0%	100.0%	100.0%	0.0%	0.0%	0.0%	0.0%	100.0%	100.0%	0.0%	0.0%	0.0%	0.0%	100.0%	100.0%	
Bicycles on Crosswalk	0	0	0	0	0	0	0	0	0	0	0	0	0	0	0	0	0	0	
% Bicycles on Crosswalk	0.0%	0.0%	0.0%	0.0%	0.0%	0.0%	0.0%	0.0%	0.0%	0.0%	0.0%	0.0%	0.0%	0.0%	0.0%	0.0%	0.0%	0.0%	

Turning Movement Data Plot

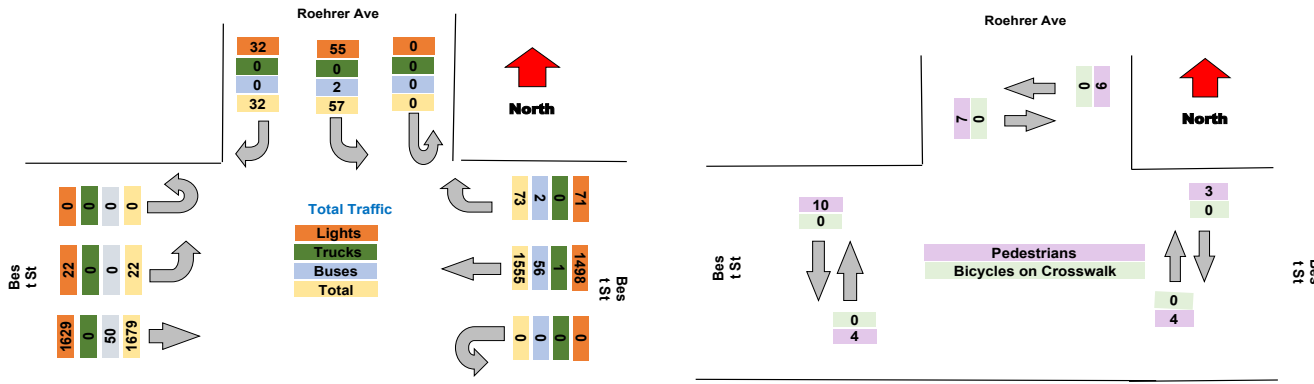

Turning Movement Peak Hour Data (AM)

7:30:00 AM

Leg Direction	Roehrer Ave Southbound						Best St Westbound						Best St Eastbound						Total
	Right	Left	U-Turn	App Total	Peds CW	Peds CCW	Right	Thru	U-Turn	App Total	Peds CW	Peds CCW	Thru	Left	U-Turn	App Total	Peds CW	Peds CCW	
7:30:00 AM	1	2	0	3	0	0	4	110	0	114	0	0	97	0	0	97	0	0	214
7:45:00 AM	0	5	0	5	0	1	2	142	0	145	0	0	130	2	0	132	0	0	282
8:00:00 AM	0	4	0	4	0	0	7	134	0	141	1	0	117	1	0	119	0	3	264
8:15:00 AM	2	1	0	3	0	1	6	121	0	128	0	0	83	0	0	83	0	0	214
<b>Grand Total</b>	3	12	0	15	0	2	19	507	0	528	1	0	427	3	0	431	0	3	974
% Approach	20.0%	80.0%	0.0%	0.0%	0.0%	0.0%	3.6%	96.0%	0.0%	0.0%	0.0%	0.0%	99.1%	0.7%	0.0%	0.0%	0.0%	0.0%	
% Total	0.3%	1.2%	0.0%	1.5%	0.0%	0.0%	2.0%	52.1%	0.0%	54.2%	0.0%	0.0%	43.8%	0.3%	0.0%	44.3%	0.0%	0.0%	
PHF	0.375	0.600	0.000	0.750	0.000	0.000	0.679	0.893	0.000	0.910	0.000	0.000	0.821	0.375	0.000	0.816	0.000	0.000	0.863
Lights	3	12	0	15	0	0	19	489	0	508	0	0	416	3	0	419	0	0	942
% Lights	#####	100.0%	0.0%	100.0%	0.0%	0.0%	100.0%	96.4%	0.0%	96.2%	0.0%	0.0%	97.4%	100.0%	0.0%	97.2%	0.0%	0.0%	96.7%
Trucks	0	0	0	0	0	0	0	0	0	0	0	0	0	0	0	0	0	0	0
% Trucks	0.0%	0.0%	0.0%	0.0%	0.0%	0.0%	0.0%	0.0%	0.0%	0.0%	0.0%	0.0%	0.0%	0.0%	0.0%	0.0%	0.0%	0.0%	0.0%
Buses	0	0	0	0	0	0	0	18	0	18	0	0	11	0	0	11	0	0	29
% Buses	0.0%	0.0%	0.0%	0.0%	0.0%	0.0%	0.0%	3.6%	0.0%	0.0%	0.0%	0.0%	2.6%	0.0%	0.0%	0.0%	0.0%	0.0%	3.0%
Pedestrians	0	0	0	0	0	2	0	0	0	1	0	0	0	0	0	0	0	3	0
% Pedestrians	0.0%	0.0%	0.0%	0.0%	0.0%	100.0%	0.0%	0.0%	0.0%	0.0%	100.0%	0.0%	0.0%	0.0%	0.0%	0.0%	0.0%	100.0%	0.0%
Bicycles on Crosswalk	0	0	0	0	0	0	0	0	0	0	0	0	0	0	0	0	0	0	0
% Bicycles on Crosswalk	0.0%	0.0%	0.0%	0.0%	0.0%	0.0%	0.0%	0.0%	0.0%	0.0%	0.0%	0.0%	0.0%	0.0%	0.0%	0.0%	0.0%	0.0%	0.0%

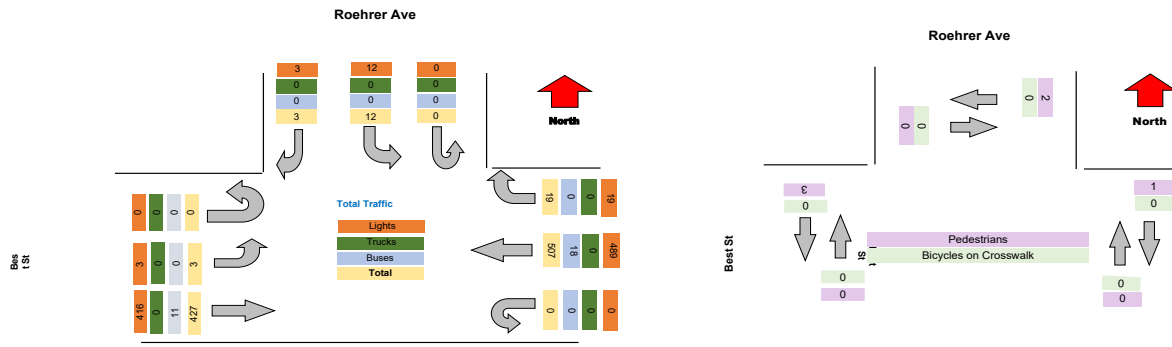



Project : VBH Malta NY  
Site : Site 4  
Location : 42.948550, -73.790036

TSTData.com

Survey Date : 2021-04-28, Wednesday

Project	LaBella
Project Code	LaBella
Site Name	V
Legs and Movements	All Processed Legs & Move
Bin Size	15 minutes
Survey Date	2021-11-02, Tuesday
Location	V
Latitude and Longitude	42.908321, -78.853973

	Start	End	PHF
Forced Peak AM	2021/11/02 07:30:00	2021/11/02 08:30:00	0.81
Forced Peak PM	2021/11/02 16:30:00	2021/11/02 17:30:00	0.91
AM Peak	2021/11/02 07:30:00	2021/11/02 08:30:00	0.81
PM Peak	2021/11/02 16:15:00	2021/11/02 17:15:00	0.89

### Turning Movement Data

Leg Direction	Jefferson Ave										Kingsley St										Jefferson Ave										Eaton St										Total
	Southbound					Westbound					Northbound					Eastbound					Eastbound																				
	Right	Thru	Left	U-Turn	App Total	Right	Thru	Left	U-Turn	App Total	Right	Thru	Left	U-Turn	App Total	Right	Thru	Left	U-Turn	App Total	Right	Thru	Left	U-Turn	App Total																
6:30:00 AM	0	13	0	0	13	0	1	0	0	1	0	17	0	0	17	0	0	0	0	0	0	0	0	0	0																
6:45:00 AM	0	16	0	0	16	0	0	0	0	0	0	22	1	0	24	0	0	0	0	0	1	0	1	0	2																
Hourly Total	0	29	0	0	29	0	1	0	0	1	0	39	1	0	42	0	0	0	0	0	1	0	1	0	2																
7:00:00 AM	0	15	0	0	15	0	1	0	0	1	0	34	0	0	34	0	0	0	0	0	0	0	0	0	0																
7:15:00 AM	2	29	0	0	31	0	0	0	0	0	0	28	0	0	28	0	0	0	0	0	1	1	0	0	2																
7:30:00 AM	2	23	1	0	26	2	2	2	0	6	0	25	1	0	27	0	0	0	0	0	0	2	0	0	2																
7:45:00 AM	0	26	1	0	27	1	0	1	0	2	0	27	0	0	27	0	0	0	0	0	1	0	0	0	1																
Hourly Total	4	93	2	0	99	3	3	3	0	9	0	112	1	0	115	0	0	0	0	0	2	3	0	0	5																
8:00:00 AM	1	35	2	0	38	2	0	1	0	3	1	33	0	0	36	0	0	0	0	0	1	0	1	0	2																
8:15:00 AM	1	48	1	0	50	1	1	1	0	3	1	0	28	2	31	1	0	0	0	1	0	2	2	0	4																
Hourly Total	2	83	3	0	88	3	1	2	0	6	1	61	2	0	66	1	0	0	0	1	1	2	3	0	6																
4:00:00 PM	1	75	0	0	76	1	1	0	0	2	1	73	1	0	75	0	0	0	0	0	5	2	4	0	11																
4:15:00 PM	1	60	1	0	62	1	3	1	0	5	1	67	0	0	67	0	0	0	0	0	7	1	0	0	8																
4:30:00 PM	2	80	3	0	85	0	0	1	0	1	0	82	2	0	84	0	0	0	0	0	3	1	2	0	6																
4:45:00 PM	4	60	2	0	66	0	1	1	0	2	2	72	0	0	74	0	0	0	0	0	1	3	1	0	5																
Hourly Total	8	275	6	0	289	2	5	3	0	10	3	294	3	0	300	0	0	0	0	0	16	7	7	0	30																
5:00:00 PM	0	61	2	0	63	1	4	1	0	6	2	66	3	0	71	1	1	0	0	2	0	1	3	0	4																
5:15:00 PM	1	81	3	0	85	0	4	0	0	4	0	60	0	0	60	0	0	0	0	0	3	1	0	0	4																
5:30:00 PM	3	57	0	0	60	3	2	0	0	5	0	68	1	0	69	0	0	0	0	0	4	1	2	0	7																
5:45:00 PM	1	60	3	0	64	0	0	2	0	2	0	61	0	0	61	0	0	0	0	0	1	1	1	0	3																
Hourly Total	5	259	8	0	272	6	6	3	0	15	2	275	4	0	281	1	1	0	0	2	8	4	6	0	18																
Grand Total	19	739	19	0	777	17	16	11	0	45	6	781	11	0	804	2	1	0	0	3	28	16	17	0	61																
% Approach	2.4%	95.1%	2.4%	0.0%	0.0%	37.8%	35.6%	24.4%	0.0%	0.0%	0.7%	97.1%	1.4%	0.0%	0.0%	0.0%	0.0%	0.0%	0.0%	0.0%	45.9%	26.2%	27.9%	0.0%	0.0%																
% Total	1.1%	43.8%	1.1%	0.0%	46.1%	1.0%	0.9%	0.7%	0.0%	2.7%	0.4%	46.3%	0.7%	0.0%	47.7%	0.0%	0.0%	0.0%	0.0%	0.0%	1.7%	0.9%	1.0%	0.0%	3.6%																
Lights	19	728	19	0	766	17	16	11	0	44	6	765	11	0	782	0	0	0	0	0	28	16	17	0	61																
% Lights	100.0%	98.5%	100.0%	0.0%	98.6%	100.0%	100.0%	100.0%	0.0%	97.8%	100.0%	98.0%	100.0%	0.0%	97.3%	0.0%	0.0%	0.0%	0.0%	0.0%	100.0%	100.0%	100.0%	0.0%	100.0%																
Trucks	0	1	0	0	1	0	0	0	0	0	0	0	0	0	0	0	0	0	0	0	0	0	0	0	0																
% Trucks	0.0%	0.1%	0.0%	0.0%	0.1%	0.0%	0.0%	0.0%	0.0%	0.0%	0.0%	0.0%	0.0%	0.0%	0.0%	0.0%	0.0%	0.0%	0.0%	0.0%	0.0%	0.0%	0.0%	0.0%	0.0%																
Buses	0	10	0	0	10	0	0	0	0	0	0	15	0	0	15	0	0	0	0	0	0	0	0	0	0																
% Buses	0.0%	1.4%	0.0%	0.0%	0.0%	0.0%	0.0%	0.0%	0.0%	0.0%	0.0%	1.9%	0.0%	0.0%	0.0%	0.0%	0.0%	0.0%	0.0%	0.0%	0.0%	0.0%	0.0%	0.0%	0.0%																
Pedestrians	0	0	0	0	0	0	0	0	0	0	0	0	0	0	0	2	1	0	0	3	0	0	0	0	0																
% Pedestrians	0.0%	0.0%	0.0%	0.0%	0.0%	0.0%	0.0%	0.0%	0.0%	0.0%	0.0%	0.0%	0.0%	0.0%	0.0%	100.0%	100.0%	0.0%	0.0%	0.0%	0.0%	0.0%	0.0%	0.0%	0.0%																
Bicycles on Crosswalk	0	0	0	0	0	0	0	0	0	0	0	0	0	0	0	0	0	0	0	0	0	0	0	0	0																
% Bicycles on Crosswalk	0.0%	0.0%	0.0%	0.0%	0.0%	0.0%	0.0%	0.0%	0.0%	0.0%	0.0%	0.0%	0.0%	0.0%	0.0%	0.0%	0.0%	0.0%	0.0%	0.0%	0.0%	0.0%	0.0%	0.0%	0.0%																

Project : VBH Malta NY  
 Site : Site 4  
 Location : 42.948550, -73.790036  
 Survey Date : 2021-04-28, Wednesday

### Turning Movement Data Plot

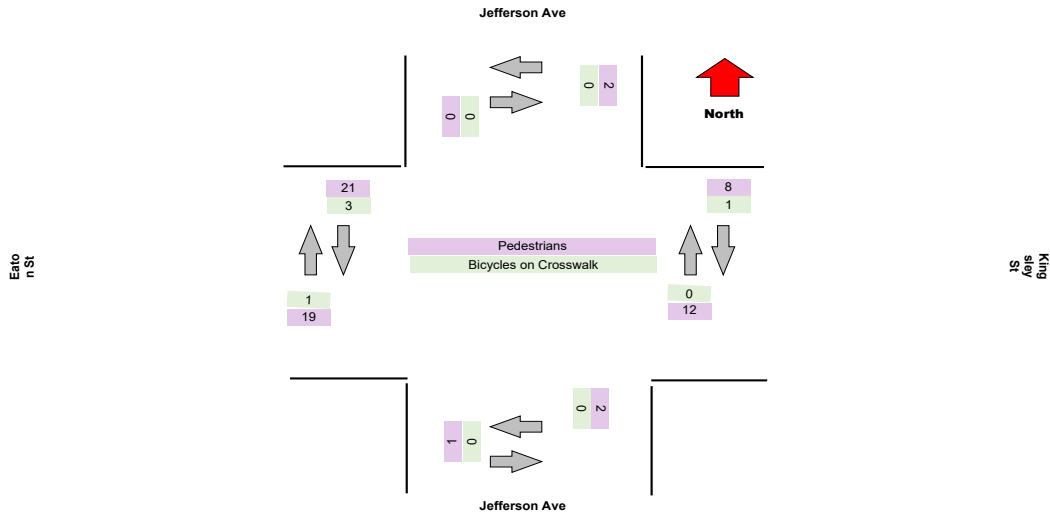
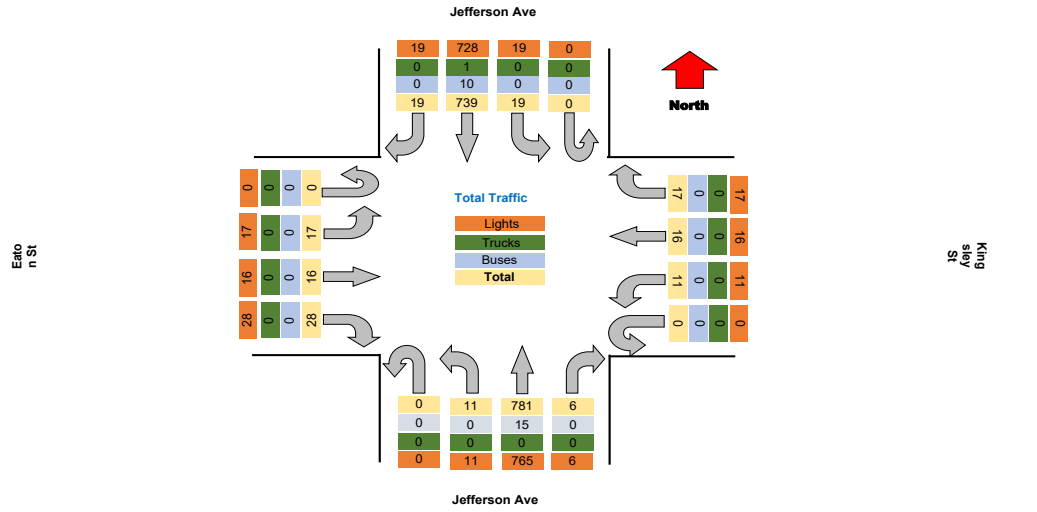

**Turning Movement Peak Hour Data (AM)**

7:30:00 AM

Leg Direction	Jefferson Ave						Kingsley St						Jefferson Ave						Eaton St						Total				
	Southbound			Northbound			Westbound			Eastbound			Northbound			Eastbound													
Start Time	Right	Thru	Left	U-Turn	App Total	Peds CW	Peds CCW	Right	Thru	Left	U-Turn	App Total	Peds CW	Peds CCW	Right	Thru	Left	U-Turn	App Total	Peds CW	Peds CCW	Right	Thru	Left	U-Turn	App Total	Peds CW	Peds CCW	
7:30:00 AM	2	23	1	0	26	0	0	2	2	2	0	6	0	1	0	25	1	0	27	0	0	0	2	0	0	2	2	1	61
7:45:00 AM	0	26	1	0	27	0	1	1	0	1	0	3	1	0	0	27	0	0	28	0	0	1	0	0	1	0	3	59	
8:00:00 AM	1	35	2	0	38	0	0	2	0	1	0	3	1	0	1	33	0	0	35	0	0	1	0	1	2	0	4	78	
8:15:00 AM	1	48	1	0	50	0	0	1	1	1	0	3	1	0	0	28	2	0	31	1	0	0	2	2	0	4	1	88	
<b>Grand Total</b>	<b>4</b>	<b>132</b>	<b>5</b>	<b>0</b>	<b>141</b>	<b>0</b>	<b>1</b>	<b>6</b>	<b>3</b>	<b>5</b>	<b>0</b>	<b>15</b>	<b>2</b>	<b>1</b>	<b>113</b>	<b>3</b>	<b>0</b>	<b>121</b>	<b>1</b>	<b>0</b>	<b>0</b>	<b>2</b>	<b>4</b>	<b>3</b>	<b>0</b>	<b>9</b>	<b>3</b>	<b>288</b>	
% Approach	2.8%	93.6%	3.5%	0.0%	0.0%	0.0%	0.0%	40.0%	20.0%	33.3%	0.0%	0.0%	0.0%	0.0%	0.8%	93.4%	2.5%	0.0%	0.0%	0.0%	0.0%	22.2%	44.4%	33.3%	0.0%	0.0%	0.0%	0.0%	
% Total	1.4%	46.2%	1.7%	0.0%	49.3%	0.0%	0.0%	2.1%	1.0%	1.7%	0.0%	5.2%	0.0%	0.0%	0.3%	39.5%	1.0%	0.0%	42.3%	0.0%	0.0%	0.7%	1.4%	1.0%	0.0%	3.1%	0.0%	0.0%	
PHF	0.500	0.688	0.625	0.000	0.705	0.000	0.000	0.750	0.375	0.625	0.000	0.625	0.000	0.000	0.250	0.856	0.375	0.000	0.864	0.000	0.000	0.500	1.500	0.375	0.000	0.563	0.000	0.000	0.813
Lights	4	131	5	0	140	0	0	6	3	5	0	14	0	0	1	108	3	0	112	0	0	2	4	3	0	9	0	275	
% Lights	100.0%	99.2%	100.0%	0.0%	99.3%	0.0%	0.0%	100.0%	100.0%	100.0%	0.0%	93.3%	0.0%	0.0%	100.0%	95.6%	100.0%	0.0%	92.6%	0.0%	0.0%	100.0%	100.0%	100.0%	0.0%	100.0%	0.0%	96.2%	
Trucks	0	0	0	0	0	0	0	0	0	0	0	0	0	0	0	0	0	0	0	0	0	0	0	0	0	0	0	0	
% Trucks	0.0%	0.0%	0.0%	0.0%	0.0%	0.0%	0.0%	0.0%	0.0%	0.0%	0.0%	0.0%	0.0%	0.0%	0.0%	0.0%	0.0%	0.0%	0.0%	0.0%	0.0%	0.0%	0.0%	0.0%	0.0%	0.0%	0.0%	0.0%	
Buses	0	1	0	0	1	0	0	0	0	0	0	0	0	0	0	5	0	0	5	0	0	0	0	0	0	0	0	6	
% Buses	0.0%	0.8%	0.0%	0.0%	0.0%	0.0%	0.0%	0.0%	0.0%	0.0%	0.0%	0.0%	0.0%	0.0%	0.0%	4.4%	0.0%	0.0%	0.0%	0.0%	0.0%	0.0%	0.0%	0.0%	0.0%	0.0%	0.0%	2.1%	
Pedestrians	0	0	0	0	0	1	0	0	0	0	0	2	2	0	0	0	0	0	1	0	0	0	0	0	0	0	3	4	
% Pedestrians	0.0%	0.0%	0.0%	0.0%	0.0%	100.0%	100.0%	0.0%	0.0%	0.0%	0.0%	0.0%	100.0%	100.0%	0.0%	0.0%	0.0%	0.0%	0.0%	0.0%	100.0%	0.0%	0.0%	0.0%	0.0%	0.0%	100.0%	80.0%	
Bicycles on Crosswalk	0	0	0	0	0	0	0	0	0	0	0	0	0	0	0	0	0	0	0	0	0	0	0	0	0	0	0	1	0
% Bicycles on Crosswalk	0.0%	0.0%	0.0%	0.0%	0.0%	0.0%	0.0%	0.0%	0.0%	0.0%	0.0%	0.0%	0.0%	0.0%	0.0%	0.0%	0.0%	0.0%	0.0%	0.0%	0.0%	0.0%	0.0%	0.0%	0.0%	0.0%	20.0%	0.0%	

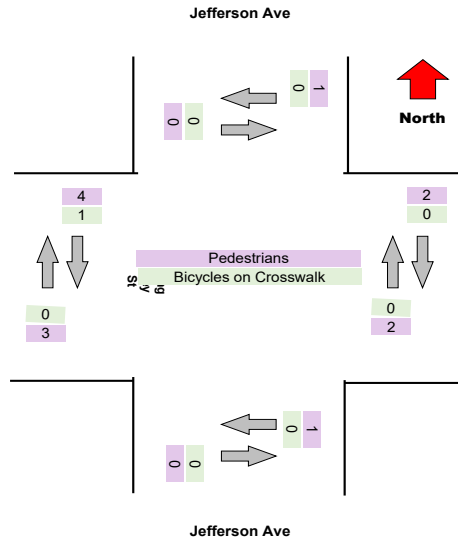
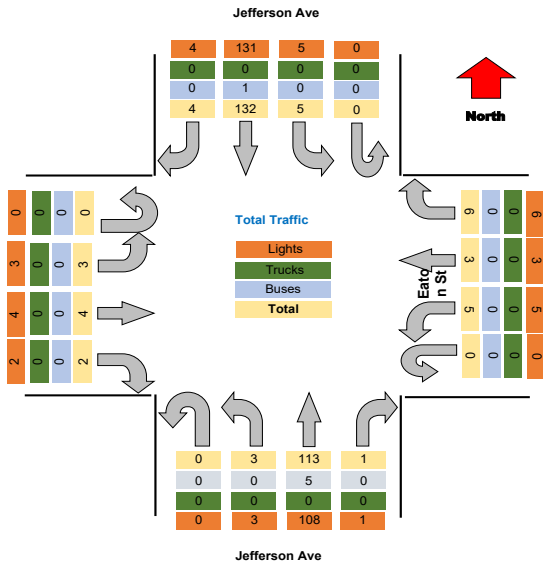

**Turning Movement Peak Hour Data (PM)**

4:15:00 PM

Leg Direction	Jefferson Ave					Kingsley St					Jefferson Ave					Eaton St					Total									
	Southbound					Westbound					Northbound					Eastbound														
	Right	Thru	Left	U-Turn	App Total	Peds CW	Peds CCW	Right	Thru	Left	U-Turn	App Total	Peds CW	Peds CCW	Right	Thru	Left	U-Turn	App Total	Peds CW		Peds CCW								
4:15:00 PM	1	60	1	0	62	0	0	1	3	1	0	5	1	1	0	67	0	0	67	0	0	7	1	0	0	8	2	1	142	
4:30:00 PM	2	80	3	0	85	0	1	0	0	1	0	1	1	1	0	82	2	0	84	0	0	3	1	2	0	6	3	4	176	
4:45:00 PM	4	60	2	0	66	0	0	0	1	1	0	2	0	3	2	72	0	0	74	0	0	1	3	1	0	5	0	1	147	
5:00:00 PM	0	61	2	0	63	0	0	1	4	1	0	6	3	1	2	66	3	0	69	1	1	0	1	3	0	4	0	3	164	
<b>Grand Total</b>	<b>7</b>	<b>261</b>	<b>8</b>	<b>0</b>	<b>276</b>	<b>0</b>	<b>0</b>	<b>2</b>	<b>8</b>	<b>4</b>	<b>0</b>	<b>14</b>	<b>5</b>	<b>6</b>	<b>4</b>	<b>337</b>	<b>5</b>	<b>0</b>	<b>316</b>	<b>1</b>	<b>1</b>	<b>11</b>	<b>6</b>	<b>6</b>	<b>0</b>	<b>23</b>	<b>3</b>	<b>9</b>	<b>629</b>	
% Approach	2.5%	94.6%	2.9%	0.0%	0.0%	0.0%	0.0%	14.3%	57.1%	28.6%	0.0%	0.0%	0.0%	0.0%	1.3%	97.2%	1.6%	0.0%	0.0%	0.0%	0.0%	47.8%	26.1%	26.1%	0.0%	0.0%	0.0%	0.0%	0.0%	
% Total	1.1%	41.5%	1.3%	0.0%	43.9%	0.0%	0.0%	0.3%	1.3%	0.6%	0.0%	2.2%	0.0%	0.0%	0.6%	48.8%	0.8%	0.0%	50.2%	0.0%	0.0%	1.7%	1.0%	1.0%	0.0%	3.7%	0.0%	0.0%	0.0%	
PHF	0.438	0.816	0.667	0.000	0.812	0.000	0.000	0.500	0.500	1.000	0.000	0.583	0.000	0.000	0.500	0.892	0.417	0.000	0.868	0.000	0.000	0.393	0.500	0.500	0.000	0.719	0.000	0.000	0.893	
Lights	7	257	8	0	272	0	0	2	8	4	0	14	0	0	4	301	5	0	310	0	0	11	6	6	0	23	0	0	619	
% Lights	100.0%	98.5%	100.0%	0.0%	98.6%	0.0%	0.0%	100.0%	100.0%	100.0%	0.0%	100.0%	0.0%	0.0%	100.0%	98.0%	100.0%	0.0%	98.1%	0.0%	0.0%	100.0%	100.0%	100.0%	0.0%	100.0%	0.0%	0.0%	98.4%	
Trucks	0	1	0	0	1	0	0	0	0	0	0	0	0	0	0	0	0	0	0	0	0	0	0	0	0	0	0	0	1	
% Trucks	0.0%	0.4%	0.0%	0.0%	0.4%	0.0%	0.0%	0.0%	0.0%	0.0%	0.0%	0.0%	0.0%	0.0%	0.0%	0.0%	0.0%	0.0%	0.0%	0.0%	0.0%	0.0%	0.0%	0.0%	0.0%	0.0%	0.0%	0.2%		
Buses	0	3	0	0	3	0	0	0	0	0	0	0	0	0	0	5	0	0	5	0	0	0	0	0	0	0	0	0	8	
% Buses	0.0%	1.1%	0.0%	0.0%	0.0%	0.0%	0.0%	0.0%	0.0%	0.0%	0.0%	0.0%	0.0%	0.0%	0.0%	1.6%	0.0%	0.0%	0.0%	0.0%	0.0%	0.0%	0.0%	0.0%	0.0%	0.0%	0.0%	0.0%	1.3%	
Pedestrians	0	0	0	0	0	0	0	0	0	0	0	4	6	0	0	0	0	0	0	1	1	0	0	0	0	0	4	8	0	
% Pedestrians	0.0%	0.0%	0.0%	0.0%	0.0%	0.0%	100.0%	0.0%	0.0%	0.0%	0.0%	0.0%	80.0%	100.0%	0.0%	0.0%	0.0%	0.0%	0.0%	0.0%	100.0%	100.0%	0.0%	0.0%	0.0%	0.0%	0.0%	80.0%	88.9%	0.0%
Bicycles on Crosswalk	0	0	0	0	0	0	0	0	0	0	0	1	0	0	0	0	0	0	0	0	0	0	0	0	0	0	1	1	0	
% Bicycles on Crosswalk	0.0%	0.0%	0.0%	0.0%	0.0%	0.0%	0.0%	0.0%	0.0%	0.0%	0.0%	20.0%	0.0%	0.0%	0.0%	0.0%	0.0%	0.0%	0.0%	0.0%	0.0%	0.0%	0.0%	0.0%	0.0%	0.0%	0.0%	20.0%	11.1%	0.0%

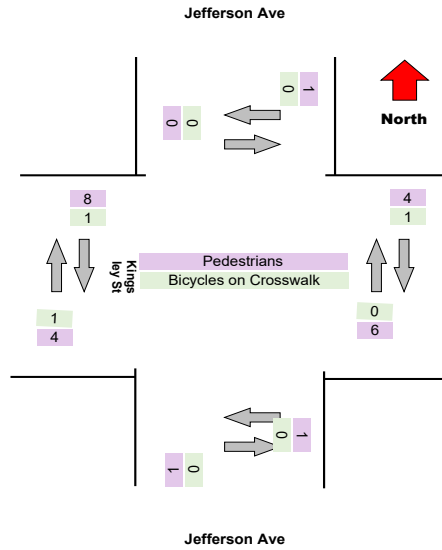
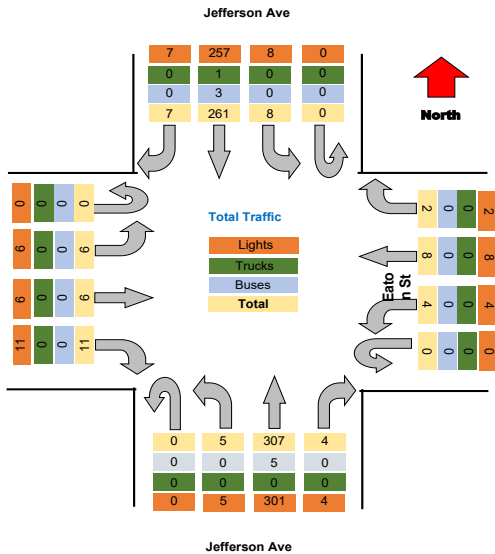



Project : VBH Malta NY  
Site : Site 4  
Location : 42.948550, -73.790036

TSTData.com

Survey Date : 2021-04-28, Wednesday

Project	LaBella
Project Code	LaBella
Site Name	V
Legs and Movements	All Processed Legs & Move
Bin Size	15 minutes
Survey Date	2021-11-03, Wednesday
Location	V
Latitude and Longitude	42.908321, -78.853973

	Start	End	PHF
Forced Peak AM	2021/11/03 07:30:00	2021/11/03 08:30:00	0.87
Forced Peak PM	2021/11/03 16:30:00	2021/11/03 17:30:00	0.86
AM Peak	2021/11/03 07:30:00	2021/11/03 08:30:00	0.87
PM Peak	2021/11/03 16:15:00	2021/11/03 17:15:00	0.89

### Turning Movement Data

Leg Direction	Jefferson Ave							Kingsley St							Jefferson Ave							Eaton St							Total		
	Southbound							Westbound							Northbound							Eastbound									
	Right	Thru	Left	U-Turn	App Total	Peds CW	Peds CCW	Right	Thru	Left	U-Turn	App Total	Peds CW	Peds CCW	Right	Thru	Left	U-Turn	App Total	Peds CW	Peds CCW	Right	Thru	Left	U-Turn	App Total	Peds CW	Peds CCW			
6:30:00 AM	0	11	2	0	13	0	0	1	2	0	0	3	1	0	0	0	20	1	0	22	0	0	0	1	0	0	1	2	0	0	39
6:45:00 AM	1	21	1	0	23	0	0	0	0	0	0	0	0	0	0	1	24	1	0	26	0	0	1	0	2	0	3	2	0	0	52
Hourly Total	1	32	3	0	36	0	0	1	2	0	0	3	1	0	0	1	44	2	0	46	0	0	1	1	2	0	4	4	0	0	91
7:00:00 AM	0	29	1	0	30	0	0	1	3	0	0	4	0	0	1	43	0	0	44	0	0	1	0	0	0	1	1	2	0	79	
7:15:00 AM	0	32	1	0	33	0	0	0	1	0	0	1	0	0	2	37	1	0	40	0	0	1	1	1	0	3	0	0	0	77	
7:30:00 AM	1	38	1	0	40	0	0	1	3	1	0	5	0	0	0	34	0	0	34	0	0	1	0	0	0	1	2	0	0	80	
7:45:00 AM	1	65	0	0	66	0	1	0	3	1	0	5	0	0	0	40	1	0	41	0	0	0	3	0	0	3	2	0	0	115	
Hourly Total	2	164	3	0	169	0	1	2	10	2	0	15	0	0	3	154	2	0	159	0	0	3	4	1	0	8	5	2	0	351	
8:00:00 AM	1	58	1	0	60	1	0	0	2	1	0	3	0	2	1	46	2	0	51	0	0	0	3	0	0	3	0	1	0	117	
8:15:00 AM	1	36	3	0	40	0	0	0	4	0	0	4	0	0	0	45	1	0	46	0	0	2	1	2	0	5	0	1	0	95	
Hourly Total	2	94	4	0	100	1	0	0	6	1	0	7	0	2	1	91	3	0	97	0	0	2	4	2	0	8	0	2	0	212	
4:00:00 PM	2	62	3	0	67	0	0	4	0	1	0	5	0	0	0	87	1	0	88	0	0	6	3	2	0	11	1	2	0	171	
4:15:00 PM	2	70	1	0	73	0	0	3	1	0	0	4	0	0	0	81	1	0	82	0	0	7	0	5	0	12	0	0	0	171	
4:30:00 PM	2	85	3	0	90	0	0	4	0	3	0	7	1	1	1	64	0	0	65	0	0	2	6	4	0	12	0	0	0	174	
4:45:00 PM	3	52	4	0	59	0	0	3	1	2	0	6	1	1	1	78	1	0	80	0	0	2	2	2	0	6	1	0	0	151	
Hourly Total	9	269	11	0	289	0	0	14	2	6	0	22	2	2	2	310	3	0	315	0	0	17	11	13	0	41	2	2	0	667	
5:00:00 PM	1	81	1	0	83	0	0	2	8	2	0	12	0	0	0	84	3	0	87	0	1	5	3	3	0	11	2	1	0	193	
5:15:00 PM	2	60	1	0	63	0	0	2	2	0	0	4	0	0	0	75	0	0	75	0	0	4	0	3	0	7	0	1	0	149	
5:30:00 PM	1	72	1	0	74	0	0	0	3	0	0	3	0	1	1	67	0	0	68	0	0	3	2	2	0	7	0	0	0	152	
5:45:00 PM	1	58	3	0	62	0	1	0	0	0	0	1	0	1	1	54	2	0	57	0	0	0	2	0	0	2	2	1	0	121	
Hourly Total	5	271	6	0	282	0	1	4	13	2	0	19	1	1	2	280	5	0	287	0	1	12	7	8	0	27	4	3	0	615	
Grand Total	19	830	27	0	876	1	2	21	33	11	0	66	4	6	9	879	15	0	906	0	1	35	27	26	0	88	15	9	1936		
% Approach	2.2%	94.7%	3.1%	0.0%	0.0%	0.0%	0.0%	31.8%	50.0%	16.7%	0.0%	0.0%	0.0%	0.0%	1.0%	97.0%	1.7%	0.0%	0.0%	0.0%	0.0%	39.8%	30.7%	29.5%	0.0%	0.0%	0.0%	0.0%	0.0%		
% Total	1.0%	42.9%	1.4%	0.0%	45.2%	0.0%	0.0%	1.1%	1.7%	0.6%	0.0%	3.4%	0.0%	0.0%	0.5%	45.4%	0.8%	0.0%	46.8%	0.0%	0.0%	1.8%	1.4%	1.3%	0.0%	4.5%	0.0%	0.0%	0.0%		
Lights	17	786	25	0	828	0	0	21	33	11	0	65	0	0	8	842	15	0	865	0	0	35	24	26	0	85	0	0	1643		
% Lights	89.5%	94.7%	92.6%	0.0%	94.5%	0.0%	0.0%	100.0%	100.0%	100.0%	0.0%	98.5%	0.0%	0.0%	88.9%	95.8%	100.0%	0.0%	95.5%	0.0%	0.0%	100.0%	88.9%	100.0%	0.0%	96.6%	0.0%	0.0%	95.2%		
Trucks	0	2	0	0	2	0	0	0	0	0	0	0	0	0	0	1	0	0	1	0	0	0	0	0	0	0	0	0	0		
% Trucks	0.0%	0.2%	0.0%	0.0%	0.2%	0.0%	0.0%	0.0%	0.0%	0.0%	0.0%	0.0%	0.0%	0.0%	0.0%	0.1%	0.0%	0.0%	0.1%	0.0%	0.0%	0.0%	0.0%	0.0%	0.0%	0.0%	0.0%	0.0%	0.2%		
Buses	2	42	2	0	46	0	0	0	0	0	0	0	0	0	1	36	0	0	37	0	0	0	3	0	0	3	0	0	86		
% Buses	10.5%	5.1%	7.4%	0.0%	0.0%	0.0%	0.0%	0.0%	0.0%	0.0%	0.0%	0.0%	0.0%	0.0%	11.1%	4.1%	0.0%	0.0%	0.0%	0.0%	0.0%	0.0%	11.1%	0.0%	0.0%	0.0%	0.0%	0.0%	4.4%		
Pedestrians	0	0	0	0	0	1	2	0	0	0	0	0	4	5	0	0	0	0	0	0	1	0	0	0	0	0	15	8	0		
% Pedestrians	0.0%	0.0%	0.0%	0.0%	0.0%	100.0%	100.0%	0.0%	0.0%	0.0%	0.0%	0.0%	100.0%	100.0%	0.0%	0.0%	0.0%	0.0%	0.0%	0.0%	100.0%	0.0%	0.0%	0.0%	0.0%	0.0%	100.0%	88.8%	0.0%		
Bicycles on Crosswalk	0	0	0	0	0	0	0	0	0	0	0	0	0	0	0	0	0	0	0	0	0	0	0	0	0	0	0	1	0		
% Bicycles on Crosswalk	0.0%	0.0%	0.0%	0.0%	0.0%	0.0%	0.0%	0.0%	0.0%	0.0%	0.0%	0.0%	0.0%	0.0%	0.0%	0.0%	0.0%	0.0%	0.0%	0.0%	0.0%	0.0%	0.0%	0.0%	0.0%	0.0%	0.0%	11.1%	0.0%		

### Turning Movement Data Plot

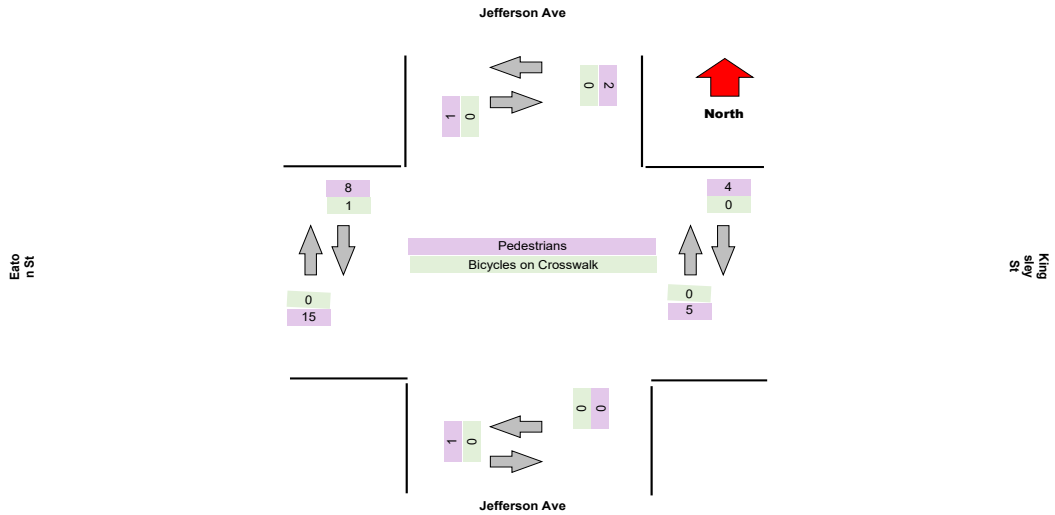
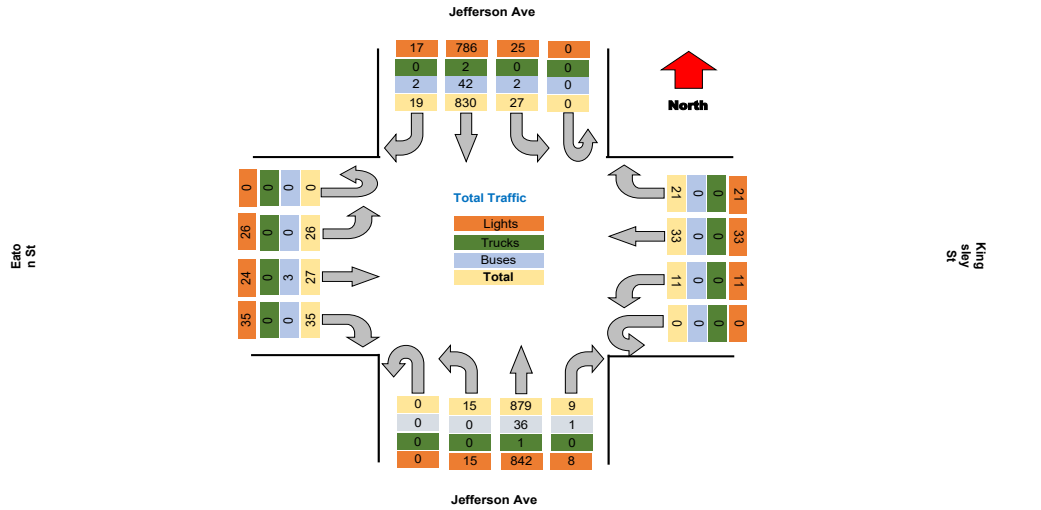

Project : VBH Malta NY  
Site : Site 4  
Location : 42.948550, -73.790036

TSTData.com

Survey Date : 2021-04-28, Wednesday

### Turning Movement Peak Hour Data (AM)

7:30:00 AM

Leg Direction	Jefferson Ave								Kingsley St								Jefferson Ave								Eaton St								Total
	Southbound				Northbound				Westbound				Eastbound				Northbound				Eastbound												
Start Time	Right	Thru	Left	U-Turn	App Total	Peds CW	Peds CCW	Right	Thru	Left	U-Turn	App Total	Peds CW	Peds CCW	Right	Thru	Left	U-Turn	App Total	Peds CW	Peds CCW	Right	Thru	Left	U-Turn	App Total	Peds CW	Peds CCW					
7:30:00 AM	1	38	1	0	40	0	0	1	3	1	0	5	0	0	0	34	0	0	34	0	0	1	0	0	1	2	0	0	80				
7:45:00 AM	1	65	0	0	66	0	1	0	3	1	0	5	0	0	0	40	1	0	41	0	0	0	3	0	0	3	2	0	115				
8:00:00 AM	1	58	1	0	60	1	0	0	2	1	0	3	0	2	1	46	2	0	51	0	0	0	3	0	0	3	0	1	117				
8:15:00 AM	1	36	3	0	40	0	0	0	4	0	0	4	0	0	0	45	1	0	46	0	0	2	1	2	0	5	0	1	95				
<b>Grand Total</b>	<b>4</b>	<b>197</b>	<b>5</b>	<b>0</b>	<b>206</b>	<b>1</b>	<b>0</b>	<b>1</b>	<b>12</b>	<b>3</b>	<b>0</b>	<b>17</b>	<b>0</b>	<b>2</b>	<b>1</b>	<b>185</b>	<b>4</b>	<b>0</b>	<b>172</b>	<b>0</b>	<b>0</b>	<b>3</b>	<b>7</b>	<b>2</b>	<b>0</b>	<b>12</b>	<b>4</b>	<b>2</b>	<b>407</b>				
% Approach	1.9%	95.6%	2.4%	0.0%	0.0%	0.0%	0.0%	5.9%	70.6%	17.6%	0.0%	0.0%	0.0%	0.0%	0.6%	95.9%	2.3%	0.0%	0.0%	0.0%	0.0%	25.0%	56.3%	16.7%	0.0%	0.0%	0.0%	0.0%	8.8%				
% Total	1.0%	48.4%	1.2%	0.0%	56.6%	0.0%	0.0%	0.2%	2.9%	0.7%	0.0%	4.2%	0.0%	0.0%	0.2%	40.5%	1.0%	0.0%	42.3%	0.0%	0.0%	0.7%	1.7%	0.5%	0.0%	2.9%	0.0%	0.0%					
PHF	1.000	0.758	0.417	0.000	0.780	0.000	0.000	0.250	0.750	0.750	0.000	0.850	0.000	0.000	0.250	0.897	0.500	0.000	0.843	0.000	0.000	0.375	0.583	0.250	0.000	0.600	0.000	0.000	0.870				
Lights	4	179	4	0	187	0	0	1	12	3	0	16	0	0	1	148	4	0	153	0	0	3	6	2	0	11	0	0	367				
% Lights	100.0%	90.9%	80.0%	0.0%	90.8%	0.0%	0.0%	100.0%	100.0%	100.0%	0.0%	94.1%	0.0%	0.0%	100.0%	89.7%	100.0%	0.0%	89.0%	0.0%	0.0%	100.0%	85.7%	100.0%	0.0%	91.7%	0.0%	0.0%	90.2%				
Trucks	0	1	0	0	1	0	0	0	0	0	0	0	0	0	0	0	0	0	0	0	0	0	0	0	0	0	0	0	1				
% Trucks	0.0%	0.5%	0.0%	0.0%	0.5%	0.0%	0.0%	0.0%	0.0%	0.0%	0.0%	0.0%	0.0%	0.0%	0.0%	0.0%	0.0%	0.0%	0.0%	0.0%	0.0%	0.0%	0.0%	0.0%	0.0%	0.0%	0.0%	0.0%	0.2%				
Buses	0	17	1	0	18	0	0	0	0	0	0	0	0	0	0	17	0	0	17	0	0	0	1	0	0	1	0	0	36				
% Buses	0.0%	8.6%	20.0%	0.0%	0.0%	0.0%	0.0%	0.0%	0.0%	0.0%	0.0%	0.0%	0.0%	0.0%	0.0%	10.3%	0.0%	0.0%	0.0%	0.0%	0.0%	0.0%	14.3%	0.0%	0.0%	0.0%	0.0%	0.0%	8.8%				
Pedestrians	0	0	0	0	0	1	1	0	0	0	0	0	2	0	0	0	0	0	0	0	0	0	0	0	0	0	4	2	0				
% Pedestrians	0.0%	0.0%	0.0%	0.0%	0.0%	100.0%	100.0%	0.0%	0.0%	0.0%	0.0%	0.0%	0.0%	100.0%	0.0%	0.0%	0.0%	0.0%	0.0%	0.0%	0.0%	0.0%	0.0%	0.0%	0.0%	0.0%	0.0%	100.0%	100.0%	0.0%			
Bicycles on Crosswalk	0	0	0	0	0	0	0	0	0	0	0	0	0	0	0	0	0	0	0	0	0	0	0	0	0	0	0	0	0				
% Bicycles on Crosswalk	0.0%	0.0%	0.0%	0.0%	0.0%	0.0%	0.0%	0.0%	0.0%	0.0%	0.0%	0.0%	0.0%	0.0%	0.0%	0.0%	0.0%	0.0%	0.0%	0.0%	0.0%	0.0%	0.0%	0.0%	0.0%	0.0%	0.0%	0.0%	0.0%	0.0%			

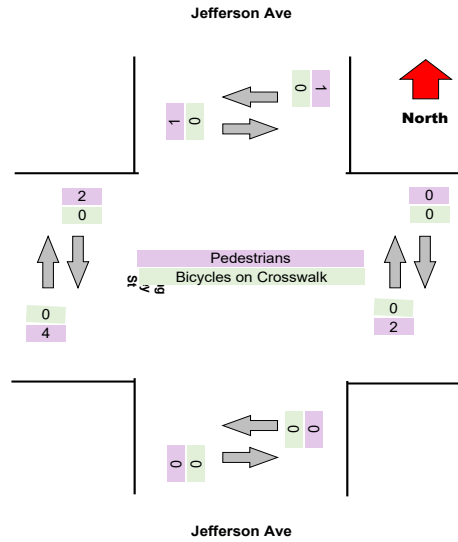
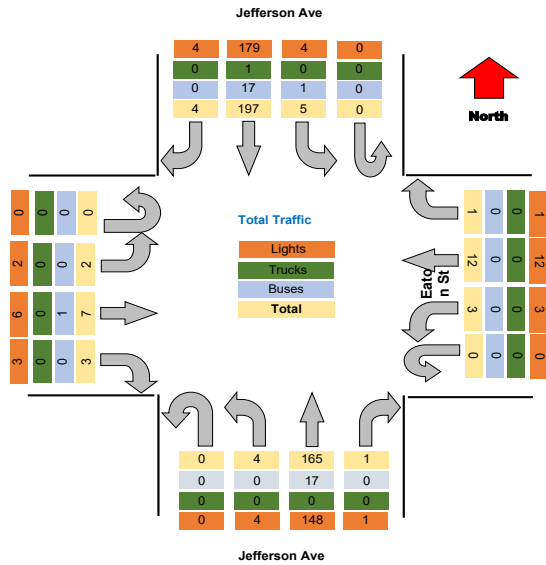

**Turning Movement Peak Hour Data (PM)**

4:15:00 PM

Leg Direction	Jefferson Ave								Kingsley St								Jefferson Ave								Eaton St								Total
	Southbound				Northbound				Westbound				Eastbound				Northbound				Eastbound												
	Right	Thru	Left	U-Turn	App Total	Peds CW	Peds CCW		Right	Thru	Left	U-Turn	App Total	Peds CW	Peds CCW		Right	Thru	Left	U-Turn	App Total	Peds CW	Peds CCW		Right	Thru	Left	U-Turn	App Total	Peds CW	Peds CCW		
4:15:00 PM	2	70	1	0	73	0	0	0	3	1	0	0	4	0	0	0	0	81	1	0	82	0	0	0	7	0	5	0	12	0	0	0	171
4:30:00 PM	2	85	3	0	90	0	0	0	4	0	3	0	7	1	1	1	1	64	0	0	65	0	0	0	2	6	4	0	12	0	0	0	174
4:45:00 PM	3	52	4	0	59	0	0	0	3	1	2	0	6	1	1	1	1	78	1	0	80	0	0	0	2	2	2	0	6	1	0	0	151
5:00:00 PM	1	84	1	0	83	0	0	0	2	8	2	0	12	0	0	0	0	84	3	0	87	0	1	1	5	3	3	0	11	2	1	1	193
<b>Grand Total</b>	<b>9</b>	<b>288</b>	<b>9</b>	<b>0</b>	<b>305</b>	<b>0</b>	<b>0</b>	<b>0</b>	<b>12</b>	<b>10</b>	<b>7</b>	<b>0</b>	<b>29</b>	<b>2</b>	<b>2</b>	<b>2</b>	<b>2</b>	<b>307</b>	<b>5</b>	<b>0</b>	<b>314</b>	<b>0</b>	<b>1</b>	<b>1</b>	<b>16</b>	<b>11</b>	<b>14</b>	<b>0</b>	<b>41</b>	<b>3</b>	<b>1</b>	<b>1</b>	<b>689</b>
% Approach	2.6%	94.4%	3.0%	0.0%	0.0%	0.0%	0.0%	0.0%	41.4%	34.5%	24.1%	0.0%	0.0%	0.0%	0.0%	0.0%	0.6%	97.8%	1.6%	0.0%	0.0%	0.0%	0.0%	0.0%	39.0%	26.8%	34.1%	0.0%	0.0%	0.0%	0.0%	0.0%	
% Total	1.2%	41.8%	1.3%	0.0%	44.3%	0.0%	0.0%	0.0%	1.7%	1.5%	1.0%	0.0%	4.2%	0.0%	0.0%	0.0%	0.3%	44.6%	0.7%	0.0%	45.6%	0.0%	0.0%	0.0%	2.3%	1.6%	2.0%	0.0%	6.0%	0.0%	0.0%	0.0%	
PHF	0.667	0.847	0.563	0.000	0.847	0.000	0.000	0.000	0.750	0.313	0.583	0.000	0.604	0.000	0.000	0.000	0.500	0.914	0.417	0.000	0.802	0.000	0.000	0.000	0.571	0.458	0.700	0.000	0.854	0.000	0.000	0.000	0.892
Lights	7	278	9	0	294	0	0	0	12	10	7	0	29	0	0	0	2	300	5	0	307	0	0	0	16	9	14	0	39	0	0	0	669
% Lights	87.5%	96.5%	100.0%	0.0%	96.4%	0.0%	0.0%	0.0%	100.0%	100.0%	100.0%	0.0%	100.0%	0.0%	0.0%	0.0%	100.0%	97.7%	100.0%	0.0%	97.8%	0.0%	0.0%	0.0%	100.0%	81.8%	100.0%	0.0%	95.1%	0.0%	0.0%	0.0%	97.1%
Trucks	0	0	0	0	0	0	0	0	0	0	0	0	0	0	0	0	0	0	0	0	0	0	0	0	0	0	0	0	0	0	0	0	0
% Trucks	0.0%	0.0%	0.0%	0.0%	0.0%	0.0%	0.0%	0.0%	0.0%	0.0%	0.0%	0.0%	0.0%	0.0%	0.0%	0.0%	0.0%	0.0%	0.0%	0.0%	0.0%	0.0%	0.0%	0.0%	0.0%	0.0%	0.0%	0.0%	0.0%	0.0%	0.0%	0.0%	0.0%
Buses	1	10	0	0	11	0	0	0	0	0	0	0	0	0	0	0	0	7	0	0	7	0	0	0	0	2	0	0	2	0	0	0	20
% Buses	12.5%	3.5%	0.0%	0.0%	0.0%	0.0%	0.0%	0.0%	0.0%	0.0%	0.0%	0.0%	0.0%	0.0%	0.0%	0.0%	0.0%	2.3%	0.0%	0.0%	0.0%	0.0%	0.0%	0.0%	0.0%	18.2%	0.0%	0.0%	0.0%	0.0%	0.0%	0.0%	2.9%
Pedestrians	0	0	0	0	0	0	0	0	0	0	0	0	2	2	2	2	0	0	0	0	0	1	0	0	0	0	0	0	0	3	0	0	0
% Pedestrians	0.0%	0.0%	0.0%	0.0%	0.0%	0.0%	0.0%	0.0%	0.0%	0.0%	0.0%	0.0%	0.0%	100.0%	100.0%	100.0%	0.0%	0.0%	0.0%	0.0%	0.0%	0.0%	0.0%	0.0%	0.0%	0.0%	0.0%	0.0%	0.0%	100.0%	0.0%	0.0%	0.0%
Bicycles on Crosswalk	0	0	0	0	0	0	0	0	0	0	0	0	0	0	0	0	0	0	0	0	0	0	0	0	0	0	0	0	0	0	0	0	0
% Bicycles on Crosswalk	0.0%	0.0%	0.0%	0.0%	0.0%	0.0%	0.0%	0.0%	0.0%	0.0%	0.0%	0.0%	0.0%	0.0%	0.0%	0.0%	0.0%	0.0%	0.0%	0.0%	0.0%	0.0%	0.0%	0.0%	0.0%	0.0%	0.0%	0.0%	0.0%	0.0%	100.0%	0.0%	0.0%

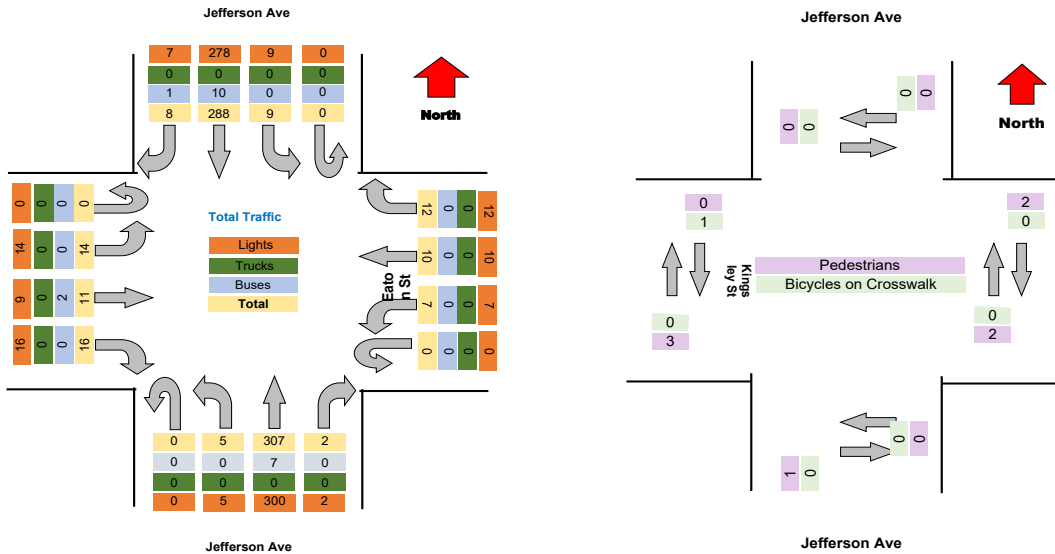

Project : VBH Malta NY  
 Site : Site 4  
 Location : 42.948550, -73.790036

TSTData.com

Survey Date : 2021-04-28, Wednesday

Project	LaBella
Project Code	LaBella
Site Name	V
Legs and Movements	All Processed Legs & Move
Bin Size	15 minutes
Survey Date	2021-11-04, Thursday
Location	V
Latitude and Longitude	42.908321, -78.853973

	Start	End	PHF
Forced Peak AM	2021/11/04 07:30:00	2021/11/04 08:30:00	0.95
Forced Peak PM	2021/11/04 16:30:00	2021/11/04 17:30:00	0.92
AM Peak	2021/11/04 07:30:00	2021/11/04 08:30:00	0.95
PM Peak	2021/11/04 16:15:00	2021/11/04 17:15:00	0.94

### Turning Movement Data

Leg Direction	Jefferson Ave										Kingsley St										Jefferson Ave										Eaton St										Total
	Southbound					Westbound					Northbound					Eastbound					Eastbound																				
	Right	Thru	Left	U-Turn	App Total	Right	Thru	Left	U-Turn	App Total	Right	Thru	Left	U-Turn	App Total	Right	Thru	Left	U-Turn	App Total	Right	Thru	Left	U-Turn	App Total																
6:30:00 AM	0	13	0	0	13	0	0	1	0	1	0	17	0	0	17	1	0	1	0	2	1	0	1	0	2																
6:45:00 AM	0	10	1	0	11	0	1	0	0	1	0	24	1	0	25	1	1	4	0	6	1	0	0	0	1																
Hourly Total	0	23	1	0	24	0	1	1	0	2	0	41	1	0	42	2	1	5	0	8	2	0	1	0	3																
7:00:00 AM	1	17	0	0	18	1	0	1	0	2	1	37	0	0	38	0	0	1	0	1	4	1	0	0	5																
7:15:00 AM	0	35	2	0	37	0	3	1	0	4	1	25	0	0	26	1	1	1	0	3	2	0	0	0	2																
7:30:00 AM	0	41	3	0	44	0	1	0	0	1	1	34	1	0	36	1	0	2	0	3	0	0	0	0	0																
7:45:00 AM	0	47	0	0	47	0	2	1	0	3	0	48	2	0	50	0	0	2	0	2	1	0	0	0	1																
Hourly Total	1	140	5	0	146	1	6	3	0	11	2	144	3	0	152	2	3	4	0	9	7	1	1	0	9																
8:00:00 AM	2	46	1	0	49	0	1	2	0	3	1	0	1	0	2	0	4	1	0	5	6	0	0	0	6																
8:15:00 AM	0	43	1	0	44	0	2	0	0	2	0	52	0	0	52	0	2	0	1	3	3	2	1	0	6																
Hourly Total	2	89	2	0	93	0	3	2	0	5	1	93	1	0	96	0	3	2	0	5	9	2	1	0	12																
4:00:00 PM	1	78	2	0	81	1	1	2	0	4	0	74	1	0	75	2	2	3	0	7	1	0	0	0	1																
4:15:00 PM	4	74	2	0	80	0	2	1	0	3	1	80	2	0	83	5	0	0	0	5	3	1	0	0	4																
4:30:00 PM	1	62	1	0	64	1	0	2	0	3	1	69	3	0	73	5	1	2	0	8	8	0	2	0	10																
4:45:00 PM	2	65	0	0	67	1	1	0	0	2	1	84	4	0	89	1	2	5	0	8	1	1	2	0	4																
Hourly Total	8	279	5	0	292	1	2	5	0	8	3	307	10	0	320	13	5	10	0	28	5	5	5	0	15																
5:00:00 PM	0	75	0	0	75	3	1	2	0	6	3	71	1	0	75	1	0	1	0	2	1	0	0	0	1																
5:15:00 PM	2	64	2	0	68	1	0	0	0	1	1	59	4	0	64	4	2	3	0	9	2	0	0	0	2																
5:30:00 PM	0	67	2	0	69	2	0	0	0	2	0	59	4	0	63	3	1	1	0	5	1	4	0	0	6																
5:45:00 PM	0	59	2	0	61	1	2	1	0	4	0	59	1	0	60	4	1	2	0	7	1	0	0	0	1																
Hourly Total	2	265	6	0	273	7	3	3	0	13	4	248	10	0	262	12	4	7	0	23	5	4	0	0	9																
Grand Total	13	796	19	0	828	10	18	15	0	44	8	833	25	0	873	32	15	30	0	77	20	11	0	0	31																
% Approach	1.6%	96.1%	2.3%	0.0%	0.0%	22.7%	40.9%	34.1%	0.0%	0.0%	1.0%	95.4%	2.9%	0.0%	0.0%	41.6%	19.5%	39.0%	0.0%	0.0%	0.0%	0.0%	0.0%	0.0%	0.0%																
% Total	0.7%	43.7%	1.0%	0.0%	45.4%	0.5%	1.0%	0.8%	0.0%	2.4%	0.5%	45.7%	1.4%	0.0%	47.9%	1.8%	0.8%	1.6%	0.0%	4.2%	0.0%	0.0%	0.0%	0.0%	0.0%																
Lights	11	759	17	0	787	10	18	13	0	41	8	791	25	0	824	31	14	29	0	74	0	0	0	0	0																
% Lights	84.6%	95.4%	89.5%	0.0%	85.0%	100.0%	100.0%	86.7%	0.0%	93.2%	88.9%	95.0%	100.0%	0.0%	94.4%	96.9%	93.3%	96.7%	0.0%	96.1%	0.0%	0.0%	0.0%	0.0%	0.0%																
Trucks	0	0	0	0	0	0	0	0	0	0	0	2	0	0	2	0	0	0	0	0	0	0	0	0	0																
% Trucks	0.0%	0.0%	0.0%	0.0%	0.0%	0.0%	0.0%	0.0%	0.0%	0.0%	0.0%	0.2%	0.0%	0.0%	0.2%	0.0%	0.0%	0.0%	0.0%	0.0%	0.0%	0.0%	0.0%	0.0%	0.0%																
Buses	2	37	2	0	41	0	0	2	0	2	1	39	0	0	40	1	1	1	0	3	0	0	0	0	0																
% Buses	15.4%	4.6%	10.5%	0.0%	0.0%	0.0%	0.0%	13.3%	0.0%	0.0%	11.1%	4.7%	0.0%	0.0%	0.0%	3.1%	6.7%	3.3%	0.0%	0.0%	0.0%	0.0%	0.0%	0.0%	0.0%																
Pedestrians	0	0	0	0	0	0	0	0	0	0	0	0	0	0	0	0	0	0	0	0	0	0	0	0	0																
% Pedestrians	0.0%	0.0%	0.0%	0.0%	0.0%	0.0%	0.0%	0.0%	0.0%	0.0%	0.0%	0.0%	0.0%	0.0%	0.0%	0.0%	0.0%	0.0%	0.0%	0.0%	0.0%	0.0%	0.0%	0.0%	0.0%																
Bicycles on Crosswalk	0	0	0	0	0	0	0	0	0	1	0	0	0	0	0	0	0	0	0	0	0	0	0	0	0																
% Bicycles on Crosswalk	0.0%	0.0%	0.0%	0.0%	0.0%	0.0%	0.0%	0.0%	0.0%	0.0%	0.0%	0.0%	0.0%	0.0%	0.0%	0.0%	0.0%	0.0%	0.0%	0.0%	0.0%	0.0%	0.0%	0.0%	0.0%																

Project : VBH Malta NY  
 Site : Site 4  
 Location : 42.948550, -73.790036  
 Survey Date : 2021-04-28, Wednesday

### Turning Movement Data Plot

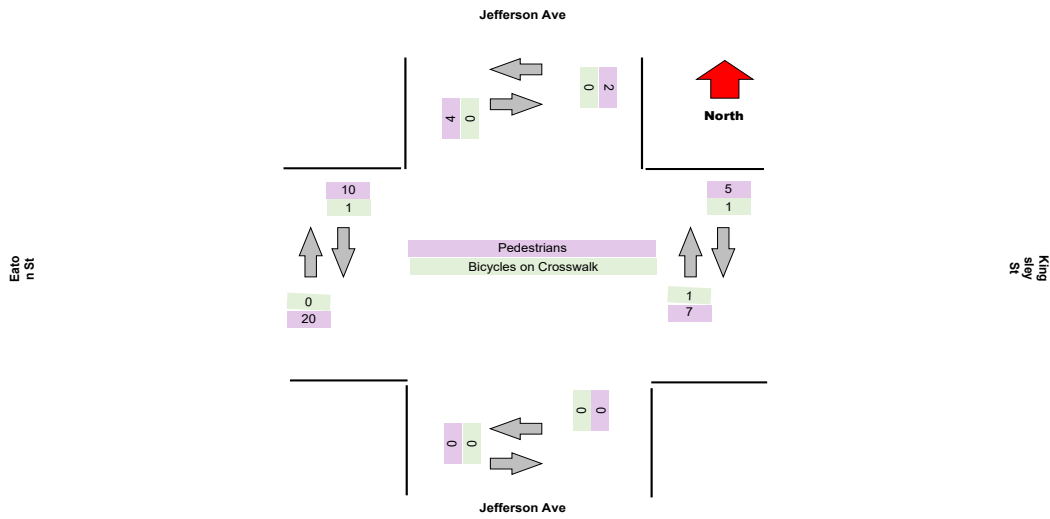
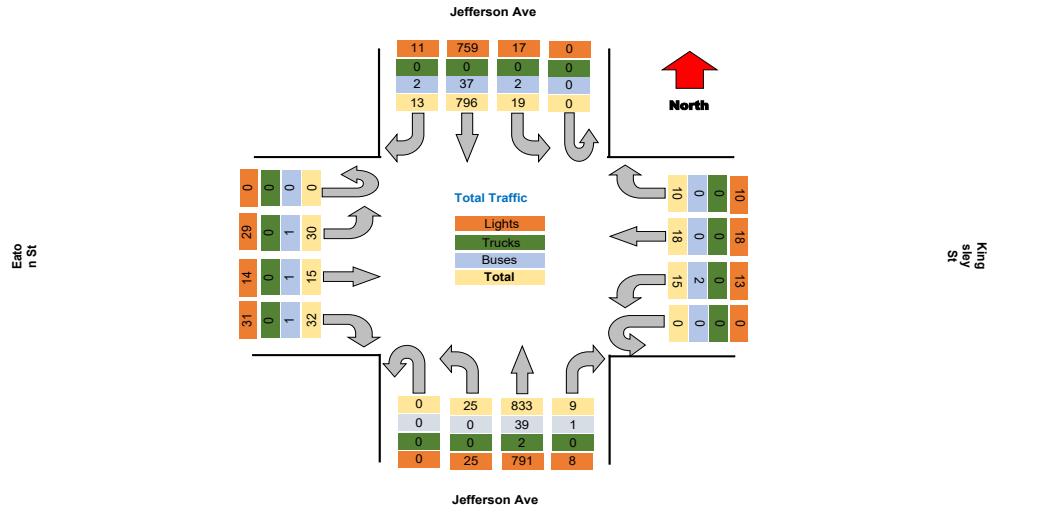

Project : VBH Malta NY  
Site : Site 4  
Location : 42.948550, -73.790036  
Survey Date : 2021-04-28, Wednesday

TSTData.com

**Turning Movement Peak Hour Data (AM)**

7:30:00 AM

Leg Direction	Jefferson Ave					Kingsley St					Jefferson Ave					Eaton St					Total									
	Right	Thru	Left	U-Turn	App Total	Peds CW	Peds CCW	Right	Thru	Left	U-Turn	App Total	Peds CW	Peds CCW	Right	Thru	Left	U-Turn	App Total	Peds CW		Peds CCW								
7:30:00 AM	0	41	3	0	44	0	0	0	0	1	0	0	1	1	0	0	0	0	37	0	0	1	0	2	0	3	0	0	85	
7:45:00 AM	0	47	0	0	47	0	2	1	0	4	0	0	0	0	0	0	0	0	50	0	0	0	2	0	0	2	1	0	103	
8:00:00 AM	2	46	1	0	49	0	1	2	0	3	1	0	0	0	0	0	0	0	43	0	0	1	2	3	0	6	0	0	101	
8:15:00 AM	0	43	1	0	44	0	2	0	0	2	0	1	0	0	0	0	0	0	53	0	0	2	0	1	0	3	2	1	102	
<b>Grand Total</b>	<b>2</b>	<b>177</b>	<b>5</b>	<b>0</b>	<b>184</b>	<b>0</b>	<b>5</b>	<b>3</b>	<b>0</b>	<b>10</b>	<b>2</b>	<b>1</b>	<b>1</b>	<b>1</b>	<b>175</b>	<b>4</b>	<b>0</b>	<b>133</b>	<b>0</b>	<b>0</b>	<b>4</b>	<b>4</b>	<b>6</b>	<b>0</b>	<b>14</b>	<b>3</b>	<b>1</b>	<b>391</b>		
% Approach	1.1%	96.2%	2.7%	0.0%	0.0%	0.0%	60.0%	30.0%	0.0%	0.0%	0.0%	0.0%	0.0%	0.0%	0.0%	0.5%	95.6%	2.2%	0.0%	0.0%	0.0%	0.0%	0.0%	28.6%	26.6%	42.9%	0.0%	0.0%	0.0%	0.0%
% Total	0.5%	45.3%	1.3%	0.0%	47.1%	0.0%	1.5%	0.8%	0.0%	2.6%	0.0%	0.0%	0.0%	0.0%	0.3%	44.8%	1.0%	0.0%	46.8%	0.0%	0.0%	0.0%	1.0%	1.0%	1.5%	0.0%	3.6%	0.0%	0.0%	
PHF	0.250	0.941	0.417	0.000	0.939	0.000	0.750	0.375	0.000	0.625	0.000	0.000	0.000	0.000	0.250	0.841	0.500	0.863	0.000	0.000	0.000	0.500	0.500	0.500	0.000	0.583	0.000	0.000	0.949	
Lights	2	165	4	0	171	0	6	3	0	9	0	0	0	0	1	158	4	0	163	0	0	0	4	3	5	0	12	0	0	355
% Lights	100.0%	93.2%	80.0%	0.0%	92.9%	0.0%	100.0%	100.0%	0.0%	90.0%	0.0%	0.0%	0.0%	0.0%	100.0%	90.3%	100.0%	89.1%	0.0%	0.0%	0.0%	100.0%	75.0%	83.3%	0.0%	85.7%	0.0%	0.0%	90.8%	
Trucks	0	0	0	0	0	0	0	0	0	0	0	0	0	0	0	1	0	0	1	0	0	0	0	0	0	0	0	0	0	1
% Trucks	0.0%	0.0%	0.0%	0.0%	0.0%	0.0%	0.0%	0.0%	0.0%	0.0%	0.0%	0.0%	0.0%	0.0%	0.0%	0.6%	0.0%	0.0%	0.5%	0.0%	0.0%	0.0%	0.0%	0.0%	0.0%	0.0%	0.0%	0.0%	0.0%	0.3%
Buses	0	12	1	0	13	0	0	0	0	0	0	0	0	0	0	16	0	0	16	0	0	0	0	1	1	0	2	0	0	31
% Buses	0.0%	6.8%	20.0%	0.0%	0.0%	0.0%	0.0%	0.0%	0.0%	0.0%	0.0%	0.0%	0.0%	0.0%	0.0%	9.1%	0.0%	0.0%	0.0%	0.0%	0.0%	0.0%	0.0%	25.0%	16.7%	0.0%	0.0%	0.0%	0.0%	7.9%
Pedestrians	0	0	0	0	0	1	1	0	0	2	1	1	0	0	0	0	0	0	0	0	0	0	0	0	0	0	0	3	1	0
% Pedestrians	0.0%	0.0%	0.0%	0.0%	0.0%	100.0%	100.0%	0.0%	0.0%	0.0%	100.0%	100.0%	0.0%	0.0%	0.0%	0.0%	0.0%	0.0%	0.0%	0.0%	0.0%	0.0%	0.0%	0.0%	0.0%	0.0%	0.0%	100.0%	100.0%	0.0%
Bicycles on Crosswalk	0	0	0	0	0	0	0	0	0	0	0	0	0	0	0	0	0	0	0	0	0	0	0	0	0	0	0	0	0	0
% Bicycles on Crosswalk	0.0%	0.0%	0.0%	0.0%	0.0%	0.0%	0.0%	0.0%	0.0%	0.0%	0.0%	0.0%	0.0%	0.0%	0.0%	0.0%	0.0%	0.0%	0.0%	0.0%	0.0%	0.0%	0.0%	0.0%	0.0%	0.0%	0.0%	0.0%	0.0%	0.0%

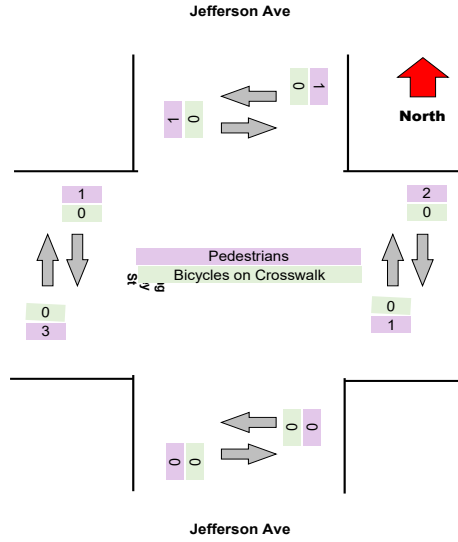
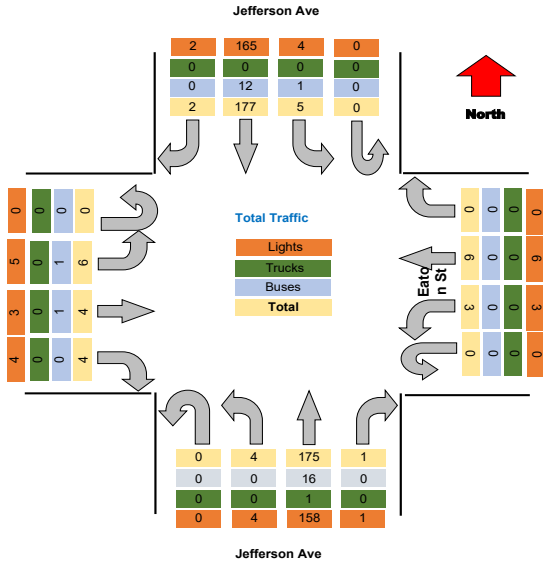

Project : VBH Malta NY  
Site : Site 4  
Location : 42.948550, -73.790036

TSTData.com

Survey Date : 2021-04-28, Wednesday

**Turning Movement Peak Hour Data (PM)**

4:15:00 PM

Leg Direction	Jefferson Ave					Kingsley St					Jefferson Ave					Eaton St					Total									
	Southbound					Westbound					Northbound					Eastbound														
	Right	Thru	Left	U-Turn	App Total	Peds CW	Peds CCW	Right	Thru	Left	U-Turn	App Total	Peds CW	Peds CCW	Right	Thru	Left	U-Turn	App Total	Peds CW		Peds CCW								
4:15:00 PM	4	74	2	0	80	0	0	0	2	1	0	3	0	0	1	80	2	0	83	0	0	5	0	0	5	3	1	171		
4:30:00 PM	1	62	1	0	64	0	0	1	0	2	0	3	1	1	1	69	3	0	73	0	0	5	1	2	8	0	2	148		
4:45:00 PM	2	65	0	0	67	1	1	0	2	1	0	3	1	1	1	84	4	0	89	0	0	1	2	5	8	1	2	167		
5:00:00 PM	0	75	0	0	75	0	0	3	1	2	0	6	0	0	3	71	1	0	75	0	0	1	0	1	0	2	1	158		
<b>Grand Total</b>	<b>7</b>	<b>276</b>	<b>3</b>	<b>0</b>	<b>286</b>	<b>1</b>	<b>1</b>	<b>4</b>	<b>5</b>	<b>6</b>	<b>0</b>	<b>15</b>	<b>2</b>	<b>6</b>	<b>6</b>	<b>304</b>	<b>10</b>	<b>0</b>	<b>320</b>	<b>0</b>	<b>0</b>	<b>12</b>	<b>3</b>	<b>8</b>	<b>0</b>	<b>23</b>	<b>3</b>	<b>644</b>		
% Approach	2.4%	96.5%	1.0%	0.0%	0.0%	0.0%	0.0%	28.7%	33.3%	40.0%	0.0%	0.0%	0.0%	0.0%	1.9%	95.0%	3.1%	0.0%	0.0%	0.0%	0.0%	52.2%	13.0%	34.8%	0.0%	0.0%	0.0%	0.0%		
% Total	1.1%	42.9%	0.5%	0.0%	44.4%	0.0%	0.0%	0.6%	0.8%	0.9%	0.0%	2.3%	0.0%	0.0%	0.9%	47.2%	1.6%	0.0%	49.7%	0.0%	0.0%	1.9%	0.5%	1.2%	0.0%	3.6%	0.0%	0.0%		
PHF	0.438	0.920	0.375	0.000	0.894	0.000	0.000	0.333	0.625	0.750	0.000	0.625	0.000	0.000	0.500	0.905	0.625	0.000	0.899	0.000	0.000	0.600	0.375	0.400	0.000	0.719	0.000	0.000	0.942	
Lights	6	266	3	0	275	0	0	4	5	6	0	15	0	0	5	294	10	0	309	0	0	11	3	8	0	22	0	0	621	
% Lights	85.7%	96.4%	100.0%	0.0%	96.2%	0.0%	0.0%	100.0%	100.0%	100.0%	0.0%	100.0%	0.0%	0.0%	83.3%	96.7%	100.0%	0.0%	96.6%	0.0%	0.0%	91.7%	100.0%	100.0%	0.0%	95.7%	0.0%	0.0%	96.4%	
Trucks	0	0	0	0	0	0	0	0	0	0	0	0	0	0	0	0	0	0	0	0	0	0	0	0	0	0	0	0	0	
% Trucks	0.0%	0.0%	0.0%	0.0%	0.0%	0.0%	0.0%	0.0%	0.0%	0.0%	0.0%	0.0%	0.0%	0.0%	0.0%	0.0%	0.0%	0.0%	0.0%	0.0%	0.0%	0.0%	0.0%	0.0%	0.0%	0.0%	0.0%	0.0%	0.0%	
Buses	1	10	0	0	11	0	0	0	0	0	0	0	0	0	1	9	0	0	10	0	0	1	0	0	0	1	0	0	22	
% Buses	14.3%	3.6%	0.0%	0.0%	0.0%	0.0%	0.0%	0.0%	0.0%	0.0%	0.0%	0.0%	0.0%	0.0%	16.7%	3.0%	0.0%	0.0%	0.0%	0.0%	0.0%	8.3%	0.0%	0.0%	0.0%	0.0%	0.0%	0.0%	3.4%	
Pedestrians	0	0	0	0	0	1	1	0	0	0	0	2	4	0	0	0	0	0	0	0	0	0	0	0	0	0	5	4	0	
% Pedestrians	0.0%	0.0%	0.0%	0.0%	0.0%	100.0%	100.0%	0.0%	0.0%	0.0%	0.0%	0.0%	100.0%	80.0%	0.0%	0.0%	0.0%	0.0%	0.0%	0.0%	0.0%	0.0%	0.0%	0.0%	0.0%	0.0%	0.0%	100.0%	80.0%	0.0%
Bicycles on Crosswalk	0	0	0	0	0	0	0	0	0	0	0	1	0	0	0	0	0	0	0	0	0	0	0	0	0	0	0	1	0	
% Bicycles on Crosswalk	0.0%	0.0%	0.0%	0.0%	0.0%	0.0%	0.0%	0.0%	0.0%	0.0%	0.0%	0.0%	20.0%	0.0%	0.0%	0.0%	0.0%	0.0%	0.0%	0.0%	0.0%	0.0%	0.0%	0.0%	0.0%	0.0%	0.0%	20.0%	0.0%	

